



# **IACSS 2013**

International Academic Conference on Social Sciences

27-28 July 2013 – Istanbul, Turkey

Conference Proceedings

## IACSS 2013

All rights reserved. No part of this publication may be reproduced, stored in a retrieval system, or transmitted in any form or by any means, electronic, mechanical, photocopying, recording or otherwise, without either the prior written permission of the publisher.

Proceedings of the International Academic Conference on Social Sciences

Edited by: Dr. Malkhaz Nakashidze

ISBN 978-9941-0-5712-0

## **CHAIRMAN OF THE ORGANIZING COMMITTEE**

**Dr. Malkhaz Nakashidze** - Shota Rustaveli Batumi State University, Georgia

## **ORGANIZING COMMITTEE**

**Prof. Ibrahim Yerebakan** – Recep Tayyip Erdogan University, Turkey

**Dr. Merab Khalvashi** – Shota Rustaveli Batumi State University, Georgia

**Mr. David Mikeladze** - Central European University, Hungary

**Dr. Malkhaz Nakashidze** - Shota Rustaveli Batumi State University, Georgia

**Prof. Helio Arthur Reis Irigaray** – Fundação Getulio Vargas – EBAPE, Brazil

**Prof. Aydin Tufkcioglu** – Artvin Coruh University, Turkey

## **PROGRAM COMMITTEE**

**Prof. Robert Elgie** – Dublin City University, Ireland

**Prof. David A. Schultz** – Hamline University, USA

**Dr. Erdogan Ekiz** – King Abdulaziz University, Kingdom of Saudi Arabia

**Dr. Scott Cohen** – University of Surrey, UK

**Prof. Dimitrios Buhalis** – Bournemouth University, UK

**Prof. Dr. Çağrı Erhan** - Ankara University, Turkey

**Prof. Martyn Percy** – Ripon College Cuddesdon, Oxford, UK

**Prof. Helio Arthur Reis Irigaray** – Fundação Getulio Vargas – EBAPE, Brazil

**Dr. Maia Chankseliany** – Oxford University, UK

**Dr. Emmanuelle Schon** – University College Cork, Ireland

**Dr. Simo Matias Mikkonen** – University of Jyväskylä, Finland

**Dr. Osman Köse** – Ondokuz Mayıs University, Turkey

**Dr. Daniel Stockemer** – University of Ottawa, Canada

**Prof. Diana Hess** – University of Wisconsin-Madison, USA

**Dr. Yavuz Bayram** – Ondokuz Mayıs University, Turkey

**Dr. Francesca Vassallo** – University of Southern Maine, USA  
**Prof. Wolfgang Babeck** – Bond University, Australia  
**Dr. Erdal Abdulhakimoğullar** – Ondokuz Mayıs University, Turkey  
**Prof. Richard Wilk** – Indiana University, USA  
**Prof. Giusto Traina** -University Paris-Sorbonne (Paris IV), France  
**Prof. Margarethe Überwimmer** – University of Applied Sciences Upper Austria  
**Prof. Don Ross** – University of Cape Town, South Africa  
**Prof. Richard Woodfield** – Universities of Birmingham, UK  
**Prof. Rodrigo Mariath Zeidan** – Fundação Dom Cabral, Brazil  
**Dr. Semih Guneri** – Izmir University, Turkey  
**Prof. Marco Frey** – Scuola Superiore Sant’Anna, Italy  
**Prof. Robert Launay** - Northwestern University, USA  
**Prof. Dominique Kassab Tezgör** – Bilkent University, Turkey  
**Dr. Armen Mazmanyán** – Columbia University, USA  
**Prof. Ali Rahnema** – American University of Paris, France  
**Prof. Erkan Perşembe** – Ondokuz Mayıs University, Turkey  
**Prof. Willibald Ruch** – University of Zurich, Switzerland  
**Prof. Burhanettin Tatar** – Ondokuz Mayıs University, Turkey  
**Prof. Konstantinos Chryssogonos** – Aristotle University of Thessaloniki, Greece  
**Prof. Cafer Sadik Yaran** – Ondokuz Mayıs University, Turkey,  
**Dr. April Nowell** – University of Victoria, Canada  
**Dr. Selim Eren** – Ondokuz Mayıs University, Turkey  
**Dr. Gianluca Passarelli** – University of Rome – La Sapienza, Italy  
**Dr. Hanna Shelest** – National Institute for Strategic Studies, Ukraine  
**Prof. Emmanuel Petrakis** – University of Crete, Greece  
**Prof. İge Pirnar** - Yasar University, Turkey



## **Message from the Organizing Committee Chair**

Welcome to the International Academic Conference on Social Sciences – IACSS 2013! The – IACSS 2013 provides opportunities for the delegates to exchange new ideas and experiences, to establish business or research relations and to find partners for future collaboration. The mission of IACSS 2013 is to provide a platform for researchers, academicians as well as other professionals from all over the world to present their research results in Social Sciences. The goal of our conference is to support, encourage and provide a platform for young researchers to present their research, to network within the international community of other young researchers and to seek the insight and advice of successful senior researchers during the conference. We hope the conference will be held every year and will be an ideal network for people to share experiences in several fields of social sciences.

Many people have interested in IACSS 2013 and many of them worked very hard for the conference. Thank the authors who have submitted papers and actively have participated in the conference. Many thanks to our keynote speakers: Professor Paul Heywood, Dean of faculty of Social Sciences at the University of Nottingham, UK and Professor, Dr. Sule Toktas, professor of political science at the Kadir Has University, Turkey, for accepting our invitation to be keynote speakers and participate in the IACSS 2013.

On behalf of the IACSS 2013 organizing committee, I would like to see you next year at the IACSS. We would be very pleased to receive your suggestions and comments regarding the first our conference and wishes for future event. I wish you a pleasant stay in Istanbul and successful conference.

Dr. Malkhaz Nakashidze

IACSS 2013 Organizing Committee Chair

## **Keynote Speakers**



**Professor Paul Heywood**

University of Nottingham, UK

Paul Heywood is Dean of the Faculty of Social Sciences and Sir Francis Hill Professor of European Politics at the University of Nottingham. He graduated with an MA in Politics (First Class) from the University of Edinburgh, then did postgraduate studies in Madrid and at the LSE, from where he received his MSc(Econ) and PhD (Politics). Before joining Nottingham, he taught at the University of Glasgow and at the University of London. He also worked for the Economist Intelligence Unit, London (1989-93). He has been a member of the ESRC Research Grants Board (2001-05) and was Dean of the University of Nottingham Graduate School from 2003-07. He is currently Director of the University of Nottingham's ESRC Doctoral Training Centre, which supports research students in the social sciences. Between 2003 and 2009 he was co-editor of the international journal *Government and Opposition*, and is currently Chair of the Board of Directors. Professor Heywood is author, co-author or editor of fourteen books and more than eighty journal articles and book chapters. His research focuses on political corruption, institutional design and state capacity in contemporary Europe. In 2006, he was appointed Adjunct Professor at the University of Hunan (China), where he is Senior Adviser to the Center for Clean Governance. He is a Fellow of the Royal Society of Arts (elected 2002), and an Academician of the Academy of Social Sciences (elected 2012).



**Professor, Dr. Sule Toktas**  
Kadir Has University, Turkey

Sule Toktas is a professor of political science at the Department of Political Science and Public Administration, Kadir Has University, Istanbul, Turkey. She received her Ph.D. degree from Bilkent University (dissertation entitled “Citizenship, Minorities and Immigrants: A Comparison of Turkey’s Jewish Minority and Turkish-Jewish Immigrants in Israel”) and master’s degree from the Middle East Technical University (thesis entitled “Gender Awareness of Working Women in Turkey: Academics and Teachers Graduated from the Girls’ Institutes 1960-1970”). She was formerly a Jean Monnet post-doctoral fellow at the Robert Schuman Center for Advanced Studies at the European University Institute; and a visiting scholar at the University of Wisconsin-Madison Center for Research on Gender and Women.

Prof. Toktas’s research interests include women’s studies, Turkish politics and foreign policy, minority issues and international migration. She conducted research projects which were funded by TUBITAK (the Scientific and Technological Research Council of Turkey), UN Population Fund and Turkish Academy of Sciences (TÜBA). Her publications appeared in academic journals some of which are International Migration, Middle East Policy, Political Science Quarterly, Women’s Studies International Forum, Third World Quarterly, Violence against Women, East European Quarterly, European Journal of Women Studies, Minerva, Turkish Studies, Middle Eastern Studies, Women’s History Review, Ethnic and Racial Studies, and the Muslim World. She co-authored three books on documentation of immigration in Turkey, Syria-Afghanistan politics and think-tanks and foreign policy making in Turkey.

Prof. Toktas is currently in the editorial board of the Journal of Balkan and Near Eastern Studies, Perceptions: Journal of International Affairs and Mirekoc – Migration Research Center at Koc University. She received TUBITAK Incentive Award for Social Scientists in 2009 and Junior Chamber International (JCI) Ten Outstanding Young Persons (TOYP) Awards in the category of ‘Scientific Leadership’ in 2008.

## Table of Contents

Anthropology	10
Economic and Finance	164
Education	55
History	39
Law	553
Management	307
Pshychology	137
Political Science	524
Tourism	239

**ANTHROPOLOGY**

# The Artist and the Artisan in Xinjiang (China) Central Asia: The Changing Uyghur Muslim Culture

David Makofsky

*Research Professor, Ethnic Minorities Studies Center of China  
Visiting Research Fellow, Anthropology, Queens University, Belfast  
[dmakofsky2001@yahoo.com](mailto:dmakofsky2001@yahoo.com)*

## **Abstract**

*The investigation is based on interviews with Uyghurs, a Turkic Central Asian people. The interviews took place in Kashgar, a leading city in the Western Xinjiang autonomous region of China, and Beijing. Modern culture begins with industrialization and the growth of 'modernity' (Shiner, Bourdieu). At this point historically the artist separates from the artisan, and a distinctive cultural aesthetic is born. This aesthetic reflects and gives direction to the transformation of the society. There is a wealth of social theory on the dramatic impact of the cultural break as it occurred in the West and its significance for modern Western society. As Uyghur society enters a new era, a differentiation in the social function of the artist and artisan appears; the artist is a "new person" when compared to the artisan. There will be a look at the background of the artist and on Uyghur art. Of particular interest, especially for Muslim society, is the acknowledgement of the role of women, and on the role of the artist in Uyghur culture.*

**Keywords:** *Uyghur, Anthropology of Art, Artisan, Artist*

## **1. The "Modern" System of the Arts**

The theory of "modernity" to be investigated concerns the different cultural contributions of the artist and the artisan. In the analysis of Western European history it is held that the separation of the artist and the artisan is the significant element in cultural change (Shiner, 1975, esp. 249; Mudimbe, 1993). This approach will now be extended to the world of the Turkic Central Asian people, especially those in Western China. This investigation is based on interviews with Uyghurs in Kashgar, a leading city in western Xinjiang Autonomous region of China and on research in Eastern Xinjiang and Beijing.

There was a traditional 'system of the arts' in the West before the eighteenth century; similarly this

system prevailed in Xinjiang, Central Asia in the recent past. In that system, an artist/artisan was a skilled practitioner and his/her work of art was a useful product of skilled work. An appreciation of the art was integrally connected with the artist/artisan's role in the life of the community. 'Art,' in this usage, meant approximately the same thing as the English term 'skill', a sense that has survived in phrases like 'the art of war,' 'the art of love,' and 'the art of medicine.'

In this system artisans were certainly able to express themselves individually and make profound statements through their work. Nevertheless they practiced a craft and self-expression that was limited to the bounds set by their accountability to their audience. Thus, in this system, what we call the crafts, such as textile work, were more highly honored than now, and what we call the arts, such as painting and theater were treated more like crafts than they are now.

In Western tradition, the modern system of the arts developed in connection with a market for art among the growing middle class. For the Western industrial middle class system, Fine Art was divided from the crafts to become an appropriate object of refined taste, and usefulness became a negative rather than a positive feature for a work of art. New institutions devoted to the arts, such as galleries, museums, concert halls and libraries, are now a central part of the new system. The aesthetic of cultural development and the character of the artist as a critic of modern society are derived from this tradition.

The world of Chinese Central Asia (Xinjiang) and the rest of Central Asia had a far different historical experience than that of Western Europe, and for that reason a framework such as that of Eisenstadt's "multiple modernities" (Eisenstadt, 2000) is more appropriate rather than those of the more conventional Western theorists (Lerner, 1958; Inkeles, 1974). As European technical innovations were introduced into the military in Imperial Russia and

into the Qing Dynasty in China in the Nineteenth century, the largely nomadic and agrarian peoples of Central Asia were incorporated into these respective empires. Although the people themselves were Muslim and spoke a Turkish language rather than Russian or Chinese, the process of incorporation continued. During the Twentieth century the secular leaders of the Soviet Union and the People's Republic of China subdivided these people into republics and autonomous administrative units. The secular leadership had little use for either Islam or Turkish cultural identity. In this sense the experience is very similar to the case made by Shari Cohen (Cohen, 1999), that for many of the new nations of Eastern Europe, there is an absence of history in the very areas that made the people feel different and unique, i.e., their history and cultural identity.

## 2. The Legacy of the Pre-industrial Past

To understand the distinctive cultural aesthetic of the artist and artisan in Uyghur society is to specify the features that make this distinctively Uyghur. Among the people of Xinjiang, there was a specific traditional legacy. Rachel Harris (2002, 2007) among others illustrates some of this, with her works on the Uyghur muqam, the performance music and art of this part of Central Asia. Muqam is the general term for a variety of musical practices widespread among the Uyghur communities. Because the Xinjiang region has always been marked by a high degree of cultural exchange between East and West due to its location on the hub of the Silk Road, Xinjiang Uyghur Muqam is a composite of songs, dances, folk and classical music characterized by diversity of content, dance styles, musical morphology and instruments used. Songs vary in rhyme and meter and are performed solo as well as in groups. The lyrics contain not only folk ballads but also poems written by classical Uyghur masters. They reflect the life of the Uyghur society. In Muqam ensembles the lead instruments, called *Satar* or *Ajak* may be bowed-stringed, plucked or wind instruments.

Today, community festivities in which everybody participates in the Muqam are held infrequently. The responsibility for passing on the tradition to new generations of practitioners has fallen almost exclusively on the shoulders of folk artists, and the interest of young people in Muqam is gradually declining. Today, several Muqam pieces are no longer performed, such as the "Twelve Muqam", which is over 20 hours long.



**Figure 1.** Abdukirim Nesirdin Uyghur Muqam

Figure 1 contains a painting by of a performance of the Muqam the Uyghur artist Abdukirim Nesirdin. The participants are dressed in clothing worn in the early Twentieth century. The painting is figurative, which is in the tradition of Central Asian Islam. The participants are largely male. Although the central figure is a woman, she is "covered".

As Uyghurs begin to migrate out of the province, they carry their culture with them. In a discussion of popular music in China in the first decade of this century, Baranovich (2003, esp. p.737) focuses on the contribution of Uyghurs as writers and singers to an audience that knows nothing about Xinjiang. There is special importance to Xinjiang in their songs. Although the singer is located in Beijing, he longs for his real home, thousands of kilometers away.

## 3. Xinjiang Enters the Modern Era

The Qing dynasty in China had control of the region in the 1880's. At that time Xinjiang was largely agricultural. The agricultural economy supported handicraft production and a handicraft industry; factories developed. Extraction industries such as mining in coal and jade was also present (Weimar, 2004, p. 165). This process of irrigation for farmlands, support for farming, protection of pasturelands, development of extraction industries, and support for handicrafts especially silk spinning and weaving formed the basis of the Xinjiang economy until the war period of the 1940's (Weimar, 2004, p.168). Xinjiang's distance from the coast limited opportunities for foreign investment, but its central location in Central Asia supported its place as



a trading center. After the establishment of the People's Republic of China (PRC) in 1949 and the formal incorporation of Xinjiang into the PRC in the 1950's, the PRC made a substantial investment in the region. Xinjiang's economy by today's standards in China is relatively well off. Of the 31 regions and provinces in China, Xinjiang ranks twelfth in gross domestic product with the first eleven ranking positions held by the coastal provinces.

The PRC also invested in arts and in arts education. In 1952 Xinjiang College set up an art department and in 1958, on the foundations of this department, the Xinjiang School of Art was established. Later, this became the Xinjiang College of Art. In the 1980s Xinjiang Normal University established a Department of Art, and these art schools continue to nurture many artists. At the same time, Chinese schools of Art supported large numbers of ethnic minority artists in Xinjiang. Several dozen of these artists gradually became established, forming the backbone of Xinjiang's Fine Art scene. Specialist schools of drawing and painting were also founded, such as the Xinjiang School of Painting, which had a major influence on the development of Fine Art within the region. Amateur Fine Art associations continually expanded. New life was also breathed into popular art.

#### **4. The Artisan Efforts Today**

The artisan efforts are represented by the tradition of skill craft shops. In today's stage of economic development, the Uyghur skill craftsman is engaged in an economic model of the firm in which the center of Uyghur life and craft industry is the Uyghur family (Makofsky, 2012). Large, patriarchal, Muslim, the family rather than the individual still acts as the economic unit of analysis when it comes to traditional Uyghur skill crafts. This is true despite the fact that at times social class levels are remarkably different.

Three of the Uyghur craftsmen interviews will be presented. Two of the artisans had shops on what is called "Crafts Street" in Kashgar, and one sold his wares in the Sunday Animal Bazaar.

The first of these craft shops is that of a fairly well known musical instrument maker, whose great grandfather, grandfather, father - all the males of the family- have gone into the business. This business began in this shop in Kashgar in 1949.

The shop and workshop are combined. The customers for his fine instruments are basically all Uyghur. They come to him because of the reputation

of the family shop. There are no advertisements for his instruments. People who are interested in good instruments come from all over Xinjiang, especially Western Xinjiang. The musical instrument maker is comparatively well educated, having had 13 years of formal education.

Down the street is a wood products shop. Again, the workshop and the retail shop are in the same place. The owner's father, who is now 70 years old, learned the business from a wood master in Uzbekistan. The owner has a primary school education. His two young sons (roughly eight and ten years old) are working by his side. The craftsman began working in the shop 23 years ago; and his brother also works there. The family makes all different sorts of Uyghur wood products – toy tops, rolling pins, objects that are used for the processing and decoration of "nan" (Uyghur bread). His wife paints the instruments at home, and also has a part time job. The dust and dirt, and the relatively low income earned by the shop represent a major problem.

The third craftsman is a knife maker, 33 years old. He, his father and his grandfather have all been in the knife business. He has a middle school education. The knives are made at a workshop at home, and then sold at the Sunday animal market bazaar, with his brother. Actually, in addition to the home workshop, the owner has orchards, and a blacksmith shop. The fields are divided, and his orchard is large. There is also an area adjacent to his home where goats and cows are raised. His wife makes "doppas", the Uyghur male head covering, which are also sold in the bazaar.

The artisan in the "new industrial" setting plays a more conservative role vis-à-vis Uyghur art and culture. The businessman only interacts with the outside public when members of that public seek him out. The sphere of business does not appear to change, and relies essentially on the Uyghur market to survive. There is the possibility that factory products may ultimately destroy the market; severe competition has not yet appeared.

#### **5. The Distinctive Aspects of the Uyghur Artist and the Uyghur Cultural Aesthetic**

The artist is in a far different position than the Uyghur artisan. A "new man/woman" on the cultural stage, the artist has one critical obstacle to face: There are far more artists and art practitioners than there are customers, and the Uyghur demand for art is small.

As one travels through Xinjiang and Beijing it is

immediately apparent that there are many Uyghurs involved in the visual and performing arts. A retired schoolteacher with a pension rents a space on a public street, and paints and exhibits his paintings. A young student from the university has a friend who is pursuing a degree in music and dance, and this friend is able to get employment in Uyghur clubs and even in Chinese clubs that dot Beijing.

A travel agent in Kashgar has some paintings for sale on his walls, those of a local artist with a degree from the school in Urumqi. The artist has set up a little shop that can be used to exhibit his works while he pursues other jobs nearby. The artist, Obulqassim's father is in auto and machine repair. He has had many places since graduation, but this is his new shop. Obulqassim's goal is to not have to work at other jobs. His paintings, either through the travel agent or from his shop, are sold primarily to Western tourists – not at all to Uyghurs. Obulqassim does machine repair work with his father and teaches art in Kashgar. He has both Han and Uyghur students, so his reputation is beyond the Uyghur community.

#### 5(A). Women Play an Important Role as the Object/Subject in Uyghur Art

Female modesty and the role of women in art serves as a major element in the Uyghur cultural aesthetic. The issue of female modesty is often the first thing that strikes a visitor to any Muslim society. How and why the tradition of 'protected female' has come to play this important role in Muslim life has inspired some anthropological debate (Antoun, 1968; Abu-Zahra, 1970), but the issue has been critical to the eye of nearly every observer of Muslim life.

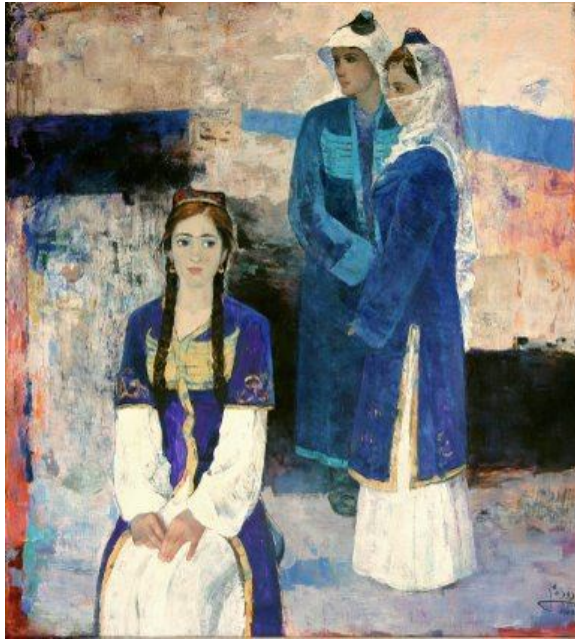
This feature of Muslim culture can be seen in artwork itself, which carries forth one tradition present in the muqam. Unlike the Western or the Chinese woman, the Muslim woman is covered, usually with head coverings and with little uncovered arms or legs. In the paintings of Zoram Yasem, as we can see in Figure 3, the females in Uyghur paintings are clothed and in a family setting.

It is difficult to escape the fact that the portrayal of women in painting has been a critical point of issue as Uyghurs interact with non-Uyghurs. This was attested to in a well-reported incident dealing with the art world that occurred nearly thirty years ago, but is just as relevant today as it was in the past.



**Figure 2.** Ting Shaokuang, Silk Road  
From James Millward's report of the event (painting referred to is Figure 2):

“In 1987, anthropologist Dru Gladney witnessed Uyghur artists protesting in Urumqi over an exhibition at the Overseas Chinese Hotel. The gallery had displayed Han paintings of Uyghurs singing, dancing, riding donkeys and balancing watermelons on their heads. Particularly offensive to many conservative Muslims was Ting Shaokuang's *Silk Road*, which depicted a woman bare-breasted with a desert caravan. As he analyzes in "Representing Nationality in China: Refiguring Majority/Minority Identities," from *The Journal of Asian Studies* (February 1994): The eroticization of minorities essentializes the imagined identity of the Han and reaffirms Han feelings of superiority. Public, state-sponsored minority representation as both more sensual and more primitive than the Han supports the state's agenda. With the proper educational and economic progress they will eventually attain the modernity that the Han have attained and enter into the same civilized restriction.”

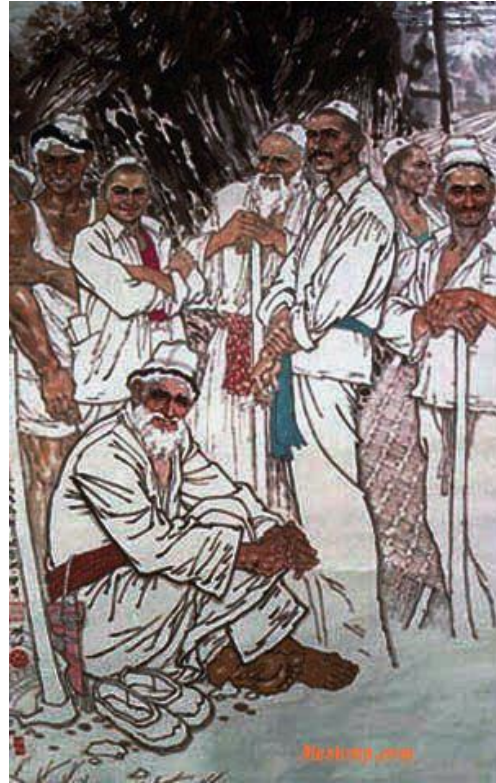


**Figure 3.** Zoram Yasem Uyghur Family

A female Uyghur painter Zoram Yasem is of particular importance in contemporary Uyghur art. She is an Assistant Professor, Vice Director in Xinjiang Art Institute. Her painting of Kariye women in the southern part of Xinjiang has gained particular attention. Another fairly well known female artist, Isimjan, paints female subjects in home-like settings.

The fact that women artists are represented in the world of Uyghur art marks a sharp contrast to what Westerners often imagine about life in Muslim Society, that females are hidden from view. Female artists and the females concerned with the arts are very much represented in Uyghur society. In the emergent culture, the protection of women does not mean the exclusion of women. Arts, museum work, education, language and literature studies all involve women. This is not restricted to Uyghur life. Winegar (2008, 2012) documents the same involvement has been shown Egyptian and Palestinian women in the arts field.

## 5(B).The Artist as the Champion of Uyghur Culture



**Figure 4.** Turdi Amin Farmers Resting

The painting shown in Figure 4, farmers resting, presents another characteristic of the Uyghur cultural aesthetic. The painter Turdi Amin was born in Kashgar in 1951 and his specialty is the painting of Uyghur daily life. The isolation of Central Asia and the difficult terrain meant that modern farm equipment was not available. There was no rail transportation to Xinjiang until the 1970's and farm equipment was not available until decades later. Uyghur farming was not mechanized until after 1990's. Simple tasks that would be handled by mechanization were carried out through collective work. One Uyghur interviewed described how, in his youth, neighbors gathered to help separate wheat kernel from chaff. The people involved in farm work would place the stalks on large blankets, wait for a strong wind, and then toss the wheat in the air. Following this, everyone would gather each piece by piece on the ground, making different piles. The person being interviewed was less than forty years

old, and he was describing a farming practice that took place in the late 1990's.

Typically, farming was a labor intensive and collective, both in Xinjiang and in the neighboring areas. Rural paintings in Kirghizstan typically show workers at a gathering at their collective farm, the kolkhoz. Turdi Amin's painting, then, is not some isolated or idealized sample. It is social realism, Central Asian style.

The earliest of the Uyghur painters committed to this school of painting were Ghazi Emitand Abdukirim Nesirdin. They shook off the subject matter of traditional painting and forged a new path of artistic creativity using differing styles and subject matter. Nasirdin's muqam (Figure 1) is a painting in traditional subject matter with a new style.

The Uyghur artist here is preserving and discovering Uyghur history with paintings of common people. There is little tradition of this type of painting, and it is the activities of the subjects that are most important. The representation of lives of common people, which captured the imagination of European painters from Breugel to Van Gogh, is now being developed in Central Asia.

## 6. Conclusion

The Uyghur artist and artisan struggle to keep the Uyghur tradition alive. The artisan continues the tradition of Uyghur crafts, but does so in the framework of a production model that may not be viable in the modern Uyghur life. The aesthetic contribution of Uyghur art certainly has a place within the emerging Xinjiang, but as yet there is no Uyghur public that demands this art.

The effort of the artisan and the artist reflects the difficulties that Uyghurs face in modern China, the choice between assimilation and cultural difference. As nearly every writer who has discussed the region has discovered, this struggle is never far from any aspect of Uyghur life.

## References

- [1] Abu-Zahra, N. M., 1970. On the Modesty of Women in Arab Muslim Villages, a Response. *American Anthropologist*, New Series, 72:5 (October, 1970), 1079-1088.
- [2] Antoun, R., 1968. On the Modesty of Women in Arab Muslim Villages. *American Anthropologist* (70) 671-697.

[3] Baranovich, N., 2003. From Margins to the Centre: the Uyghur Challenge in Beijing. *China Quarterly* 175 (September), 726-750.

[4] Cohen, S. J., 1999. *Politics without a Past: The absence of history in post-communist nationalism*, Duke University Press, Durham and London.

[5] Harris, R. and Mazar, R.W. (2002). Festivals of the Uyghurs: Music, Islam and the Chinese State. *British Journal of Ethnomusicology*, 11(1) 101-118.

[6] Harris, R., 2007. Yearbook for Traditional Music, Vol. 39, pp. 191-192.

[7] Inkeles, A. Smith, D.H., 1974. *Becoming Modern: Individual Change in Six Developing Countries*. Harvard University Press, Cambridge, Mass.

[8] Lerner, D. 1958. *The Passing of Traditional Society: Modernizing the Middle East*. Glencoe, Ill, Free Press.

[9] Makofsky, D., 2012. Zhongguo xibu jingji lingyude weiwuerzu zhizuo gongyi (xinjiang) Uyghur Skill Crafts in the Economic World of Western China (Xinjiang): Interview with the Musical Instrument Maker. *Minzu Luntan*, 229 (5, May), 56-58.

[10] Makofsky, D., 2012. Xian dai ren lei xue shi ye xia de wei wu er zu chuan tong shou gong yi wen hua ---yi yue qi zhi zuo hang ye wei li. Uyghur Skill Crafts in Developing China. *Forward Position*. 313(11) 160-163.

[11] Millward, J.A., 2011. Art Music and the Ambiguities of Chinese Silk Roadism in Xinjiang. *Silk Road Foundation Newsletter*. 3(1), 1-10.

[12] Mudimbe, V.Y., 1993. Reading and Teaching Pierre Bourdieu. *Transition*, (61), 144-160

[13] Eisenstadt, S.N., 2000. Multiple Modernities. *Daedalus*, Winter 129, (1) 1-29.

[14] Shiner, L.E., 1975. Tradition/Modernity: An Ideal Type Gone Astray. *Comparative Studies in Society and History*, 17(2), pp. 245-252.

[15] Weimer, C., 2004. The Economy in Xinjiang' in Starr, S.F., *Xinjiang, China's Muslim Borderland*,

ME Sharpe, Armonk, NY, London England, 163-190.

[16] Winegar, J., 2008. *The Formation of the Artist within a Contested Terrain: The Politics of Artistic Production in Mubarak's Egypt*. Stanford University Press, Stanford, 2004.

[17] Winegar, J., Pahwa, S., (2012). Culture, State and Revolution. *Middle East Research and Information Project*. Volume 42, 1-12, MER ONLINE 263.



# Family and Deviation in Hungarian Communities from Transylvania, during the 19<sup>th</sup> Century

Kolumbán Zsuzsánna

Babeş-Bolyai University, Cluj-Napoca, Romania  
[zsuzsannakolumban@yahoo.com](mailto:zsuzsannakolumban@yahoo.com)

## Abstract

*In terms of time, the scope of our study covers the 19<sup>th</sup> century, while in geographical terms it covers a currently non-existent administrative unit within the borders of Romania, where Odorhei Seat, and after 1876, Odorhei County was found.*

*In the 19<sup>th</sup> century the fundamental institution of society was the family. In our paper we wish to explore the process and characteristics of family founding, the structure and roles within the domestic groups etc. At the same time our archival sources enable us to follow the ecclesiastical authority's expectations for families, as well as those raised by the community. On the other hand the divorce files make traceable the individual deviant behaviour's impact on family (such as sexual crimes, forcing of marriages, aggressiveness, alcoholism, the refusal of roles and responsibilities etc.). Examining our sources both quantitatively and qualitatively, we also try to trace the transformations of moral values.*

## 1. Introduction

In terms of time, the scope of our study covers the 19<sup>th</sup> century, while in geographical terms it covers a currently non-existent administrative unit within the borders of Romania, where Odorhei Seat, and after 1876, Odorhei County was found. This county was located in the Eastern part of the Transylvanian basin. During the history, this region used to belong to different historical formations: after 1711 until the foundation of the Austro-Hungarian Monarchy in 1867 was subordinated to Habsburg rule. In 1867, it was united with Hungary.

In the 19<sup>th</sup> century, the basic institution of the society was the family, which was established by marriage concluded in accordance with the legal regulations. In this bond, which was based on moral foundations, the society saw earthly security while the church considered it as the major tool to increase the number of its faithful congregation. Consequently, the family, due its many-sided role in the society –

procreation of and bringing up children, maintenance of order and morality, legalisation of sexual life, assurance of material conditions for life, and the arrangement of inheritance with regard to acquired goods – has at all times been in the focal point of attention both by the ecclesiastic and secular powers. The purpose was to prevent sins committed against the institution of the family and the penalisation of those who abused the social rules.

According to the census data of 1869, the population of Odorhei County was 105 467.<sup>1</sup> The predominantly (98.57%) Hungarian population followed three major religions: 33% of them were Roman Catholic, 35% Calvinist and 22.57% Unitarian. Accordingly, the county consisted of four different ecclesiastical administrative units: the Roman Catholic Deanery, the Calvinist Diocese, and two Unitarian Ecclesiastic Districts. In the majority, the population lived at settlements with less than 2000 inhabitants. The centre of the county was the city of Odorhei, which had 4 376 inhabitants in 1869. Due to the characteristic features of the geographical environment, the population mostly sustained itself from animal husbandry, woodfelling and agriculture performed on small and medium size estates. The industry was mostly characterised by handicraft activities. Every farm tried to be self-sufficient, and this fact had a strong influence on the intra-family relations.

The present study tries to give a general description of the family and the deviant forms of behaviour endangering the family in the 19<sup>th</sup> century. With regard to the families, we mostly focus on those characteristics, which might be correlated with the breaking up of the families caused by deviant behaviour.

Our findings are based on written sources found in the ecclesiastic archives, namely on registers of

---

<sup>1</sup> László Sebök, comp., *Az 1869. évi népszámlálás vallási adatai* [The ecclesiastical data offered by the 1869 Census], Teleki László Intézet, KSH Népszámlálás, KSH Levéltár, Budapest, 2005, pp. 227-229.

births, marriages and deaths, records on church visits, and divorce papers. Until as late as 1895 in Transylvania, the registers of births, marriages and deaths were kept by the Church and marriages were contracted, and consequently, dissolved by the Church.<sup>2</sup> The sources selected by us are suitable for the quantitative and qualitative observation and evaluation of establishment and disintegration of families.

## **2. Establishment of families and the roles within the family**

If we examine marriages, the first thing we are struck by is the limited living space typical especially of the first half of the century. The majority of the events offering the chance to meet were usually organised within the borders of the villages, thus the majority of the married couples originated from the same or the neighbouring settlements. Based on our sources, only 25 percent of the marriages in rural communities were exogenous. We can only witness an increase in exogenous marriages in the second half of the century, indicating higher mobility of the persons. At the same time we can observe that the ratio of exogenous marriages was higher in those communities, which were smaller from denominational point of view, even if the number of the population was relatively high at village in question. This fact in itself refers to a specific strategy when choosing the partner in marriage: religious denomination was still a criterion to choose the partner in marriage.

Among the priorities followed when selecting the partner in marriage, the economic situation and social position are among the most important ones, together with moral purity. Male with relatively big farms and single female inheriting the possession and holdings of their father or receiving big dowry were the most sought after. The great importance of the economic criteria is indicated, besides others by the high number of broken up families since the marriage was forced by the parents. The power of the parents was prevalent within the families, and this phenomenon was further promoted by the fact that according to church law, parental consent was necessary for the marriage of females and those males who were economically dependent. We can identify an economic strategy, namely the desire to improve the economic situation of the family, behind forced marriages.

In ordinary cases, the engagement indicated that the relationship between the young persons became stronger. In good old days, engagement was considered to be a serious agreement. This fact is indicated by the fact that in the case of Calvinist communities, termination of the engagement fell into the authority of the partial synod. The role of the engagement was to facilitate for the future couple to know each other better, and also to verify the girl's dowry. In those cases, when the relationship was established based on the agreement between the families or the recommendation of third parties, this period was often absent from the life of the young couple. The marriage was prepared only at economic level, while the young persons could not get to know each other and this caused conflicts during the marriage.

Prior to marriage, the most delicate issue was the establishment of the girl's dowry. However, dowry was given only if the future partner in marriage was not chosen against the will of the family. The dowry, which consisted of movable and immovable property, later became the inalienable property of the wife. The dowry was managed by the husband, but without the consent of the wife the husband could not use it for example, to settle his debts, and in case of divorce, the dowry, without division, remained the women's property. Poor dowry or the inadequate management of the dowry by the husband was later the major sources of conflicts between the spouses.

Only one form of marriage, which was concluded without hindering factors, publicly and based on the consent of the parents, was officially recognised. Marriage legalised the sexual relationship according to church law, resulted in common fate, obliged the partners to mutually help each other, gave independence to the woman with regard to her parents, but at the same time, put her under the control of her husband. Women were obliged to follow their husband to the place of residence named by the husband. However, choosing the place of residence of the married couple always depended on their economic situation. If the woman was the sole heir to her father's property, and the man came from a family with several children, the newly married couple evidently moved into the house of the wife's family. In general, the families agreed upon the place of residence of the new couple prior to the marriage since the marriage depended on this decision. Problems occurred when the husband was not permitted to manage the farm at the new dwelling place. In some cases, the marriage concluded on the basis of economic considerations was 'too

---

<sup>2</sup> László Pomogyi, ed., *Corpus Juris Hungarici. CD-ROM*, KJK-KERSZÖV, Budapest, 2000, 1894/XXXI.

successful', both of the married partners had a farm, thus insistence to their own property represented an obstacle before their common life.

According to our survey, the majority of girls got married between the ages of 18-24, while most of the men married between the ages of 22-28, respecting the legal regulations. Nonetheless, there were girls who were given in marriage at the age of 14, but they, without exception, got married based on parental will. The difference between the ages of the married couple was, in 60 percent of the cases 0-5 years, men being senior to the wife in the majority of the cases. Bigger age differences between the married couple were typical of re-marriages, and mostly widowed men choose younger partners. The church added up and completed the secular regulations on the age of married couples. In the Calvinist communities, divorce was prohibited for women who chose a husband who was more than 60 years of age. In spite of this prohibition, there were conspicuous and conflict-burdened cases.

The establishment of family resulted in significant changes in the life of the young persons. The man/boy who previously was up and doing under his father's control, became the head of the family, while in the case of the woman/girl, paternal control was substituted with the control of the husband. Within the family, the husband was the leader, maintainer and protector of the family, while the wife who fulfilled the role of mother was the caretaker of the family. The wife expected from her husband protection and the provision of financial resources, while the husband expected from his wife maintenance and care of the family, nursing children and participation in the farm activities. During the 19<sup>th</sup> century, the man was entitled to the leading role in the family, since peaceful family life demanded unconditional obedience from the woman even in sexual life. Presumably, the conception which was strongly present all through the 19<sup>th</sup> century, according to which the husband exercises power over the wife, consequently he can, should the case be, penalise her if she refuse to be obedient and or deny the performance of the tasks attached to womanly role. Often enough, the method of punishment was beating, which was implicitly accepted by the society, should it not endanger the life of the woman.

In general, the first child was born in the course of the first year following the marriage, and then more children came. The registers of births indicate that the number of children born could even reach seven since contraception techniques were not used. At the same time, due to imperfect health care

provision and frequent epidemics, the mortality rate of new-born babies and children was very high: one-fourth of the children died before reaching the age of five.

Taking care of children was part of the scope of female duties, together with educating the girls and teaching them the household duties. As soon as the boys in the family became employable in the farm, they spent their time with their father. For this reason, the Unitarian Church left the boys at their father and the girls at their mother in the case of divorce. The Calvinist ecclesiastic authorities decided that children under the age of twelve should stay with their mother, with the obligation that the father should give a helping hand in their care, and then the boys shall be put up by the father to assure proper upbringing and the right process of inheritance. If the woman was considered to be morally debauched, she lost her right to bring up her children.

Children were brought up to learn the roles within the family and to perform the typical male or female work necessary to run the farm. In the industrially underdeveloped regions, where the majority of the population dealt with prime production, maintaining the family required that the family lives a very economical life. Both the man and the woman had well defined tasks within the family, which completed each other. Accordingly, the man, the breadwinner, cultivated the land which was located outside of the borders of the village, dealt with the animals, and was in charge of taking to and selling the goods on the market. As opposed to this, the woman performed the activities related to the house and the garden and she processed the produced products, helped the man to perform the seasonal agricultural activities.

The tasks of the wife and the husband completed each other. Consequently, the party which failed to perform the duties deriving from his/her position in the family, endangered the subsistence of the family, caused problems to his/her partner, who had to perform also the duties of the other, or had to pay someone to do the work. Both the parties were needed to maintain the farm, which provided the subsistence for the family. If the family was broken up due to death or divorce, the party that was left alone, especially when there were children, immediately looked for a new partner, re-married, developed a cohabitation relationship, or when the woman was left alone, tried to find refuge at the relatives.

When the family was broken up at an elderly age, the bread-winner role and the management of the



farm was taken over either by one of the sons or the husband of the daughter. The latter situation can be witnessed quite often in the divorce papers, since in the background of forcing the girls to marry we can often identify the problems caused by the farm that was left without a master due to the death of the father.

The different tasks of the men and women defined the nature of their upbringing. Since the living space of women was quite limited, little emphasis was put on their school education; the number of dropouts from school was higher in the case of girls than boys. Investigating the testimonies of 5 292 persons made during the Calvinist divorce cases taking place between 1867 and 1895 it turned out that altogether only 34% of the witnesses were literate (61.5% of men and 6.5% of women).

We can see also from the above series of data that men were given priority both in the family and the society. The male who had a bigger living space and performed more spectacular work with regard to the economic results of the work, managed the family in the possession of intellectual and financial advantages. As opposed to this, females, in the first place, were wives and mothers, their school education left much to be desired, and they seldom possessed property.

Emigration to the Romanian territories for seasonal work or household services exerted a significant influence on the development of family roles, the development of the social status of women and the changes in the moral values, which, as of the 1870s became a clearly detectable tendency in the researched region. The causes of the phenomenon do not so much lie in the growth of the number of the population but much more in the economic growth, which reached a standstill at that time.

Neither the economic nor the demographic effects of the above phenomenon can be measured due to the lack of data, but in terms of mentality, it is for sure that, besides others, emigration had a strong influence on the changes in the scale of values which had developed during the centuries. By the end of the 19<sup>th</sup> century, domestic service of girls became part of everyday life in the researched communities. After a certain period of time, domestic service was not only a source of income but also a kind of schooling for the girls, during which they could learn the different housekeeping techniques, and become more educated. Intellectual development and earning money, which had visible results, exerted influence on the re-evaluation of the status of women within the family and in the community.

Domestic service represented an opportunity for women to become independent. Girls who were forced to get married often had to tolerate their inconvenient situation for years, because they did not have any property, and their parents were unwilling to pay the costs of divorce. Starting with the 1870s, however, we can witness cases when the girls who were forced to marry escaped into domestic service right after the wedding, whereas in the case of others, earning money rendered the possibility to initiate the divorce. At the same time, the fact that domestic service became general also had drawbacks, since geographical distance loosened the control exercised by the community and the family and offered favourable conditions for sexual debauchery, and especially cohabitation.

### **3. Deviant forms of behaviour and breaking up of the family**

In certain cases, the size and quantity of compromises made at the marriage and during family life resulted in resistance and deviant behaviour. Selection of the partner in marriage by the parents or the distance between the places of residence of the married couples limited the chances to make acquaintances, but resulted in conflicts, lack of love, aggression or the escape to another partner due to the inadequate upbringing, financial status, social status, nature, outlook, etc. of the partner.

When studying the Calvinist divorce papers, we found judgements certifying and declaring the divorce altogether in 2 424 cases for the period between 1801-1806 and 1813-1895. In the Unitarian Ecclesiastic District of Cristur, divorce was declared in 720 cases between 1852 and 1895, while in the Unitarian Ecclesiastic District of Odorhei this number was 474 between 1801-1858 and 1886-1895. In the case of Roman Catholics the divorce proceedings were discussed by the Holy See of the Roman Catholic Archdiocese of Alba Iulia, and not at the level of the Roman Catholic Deanery of Odorhei. Consequently in Odorhei in the local Roman Catholic Archives divorce papers can be found sporadically, and in the Archives of the Roman Catholic Archdiocese of Alba Iulia the divorce proceedings from all over the Archdiocese are mixed, that made for us impossible to research this documents.

The rough divorce ratio (per 1 000 inhabitants) reached, and in some years exceeded 1 thousandth in the case of the Unitarians and Calvinists, while between 1876 and 1890, for example, the above indicator was only 0.08 percent in the territory of

Hungary including Transylvania.<sup>3</sup> The latter total ratio was evidently influenced by the lower divorce rates typical of the Roman Catholic population, but we failed to measure it in the case of the Roman Catholic Deanery of Odorhei.

Divorce ratio was high among the Protestant population, but the reasons for this phenomenon are, as yet, unclear. At the same time it is clear that the society did not consider divorce a deviant behaviour. It was rather interpreted as a tool to terminate the conflict between the married partners in divorce and the community. The consequence of the divorce, according to the opinion of the time, shall be the clarification of the relations, the penalisation of the sinful party and public apology asking for and giving pardon. Consequently, divorce, the legal, regulated and public termination of the marriage was far more accepted by the society than confused, illegitimate relations causing conflicts and raising scandal.

As we have already mentioned, declaring divorce fell into the competence of the Church during the 19<sup>th</sup> century. In the case of the Calvinists, divorce was declared, until 1868, by the partial synod, while between 1868 and 1895, by the diocesan marital tribunal. The forum of appeal was the general synod, and then the marital court of justice located in the city of Cluj. In the case of the Unitarian population, the sub-ecclesiastic benches took the decision at the level of the ecclesiastic districts, while the forum for appeal was the prelate bench in Cluj.

The operation and the rules of practices of the above-mentioned institutions were regulated by ecclesiastic and secular laws, and the same applies to the reasons giving the basis for the breaking up of the marriages.<sup>4</sup> Evidently, the parties who wanted to be separated never applied for divorce based on one single reason. In their case we are faced with a series of reasons, but the judgement was always made and declared based on the sin or deviant behaviour which was considered the most severe in the eyes of the Church, and this forms the basis of our statistical data.

The competent ecclesiastic forum took the decision about the invalidity or breaking up of the

marriage. The Protestant forum concluded the invalidity of the marriage, if, at the time of getting married, one of the partners had already been married, was under the prohibition to get married, was forced to marry, lost her virginity prior to the marriage, had an undisclosed illness, or was unable to have children, but this fact was kept in secrecy, etc. The marital relationship was broken up due to marital infidelity, wilful desertion, attack against the life of the marital partner, refusal of sexual relationship, and effectuation of sterility, etc. Deadly hatred, which could have been caused by drunkenness, aggression, disobedience, lack of love, neglect of the farm, thievishness, etc. could also represent the ground for divorce.

When studying the divorce papers, we managed to outline some of the most significant categories of deviant behaviour or sin which appear on the pages of the documents recording church visits. The sexual sins are also mentioned in the records of births, marriages and deaths in the case of illegitimate children.

Forced marriages and marriages concluded on persuasion tend to be frequent (but we should also mention that their number was on the decline). Among the Calvinist population, these were the causes of invalidity of the marriage in 34 percent of the cases during the first decades of the century, while their share decreased to 25 percent in the second half of the century. Since these causes were accepted as reasons for the invalidity of the marriage only for two years following the marriage, their appearance among the marriages breaking up within two years was significant. During the century, 80 percent of the divorces requested due to forced marriage were initiated by women, and this ratio increased to 95 percent by the end of the century, which is an indication of the increased initiative of women.

As we have already mentioned, the power of the parents was strong over the children all through the 19<sup>th</sup> century. The methods the parents used to enforce their will were varied, starting with feeding with promises to beatings, refusal to give dowry to being disowned from the family. Being forced to get married is typical of both boys and girls, but while in the case of boys, it is usually manifested in persuasion, in the case of girls, it was real forcing. Behind compulsion to get married we can always identify financial interests. For example, the boy chosen for the girl already possessed an independent farm, or was waiting for a rich heritage, or was a publicly esteemed person, an educated man, or the

<sup>3</sup> Tivadar Szél, "Az elválások újabb alakulása [Recent movement of divorces]," *Magyar Statisztikai Szemle*, MKSH, Budapest, 9 (1934), pp. 759-761.

<sup>4</sup> *Canones Ecclesiastici cum Benigna Constitutione Josephina de Caussis Matrimonialibus*, Georgius Csáthy, Debreczini, 1813.; Bod Péter, *Házassági törvényrajz vagy házassági törvényekről való tanítás* [Marriage law, introduction or teachings about marriage laws], Evang. Ref. Kollégium, Kolozsvár, 1836.; *Unitárius egyházi törvény a házassági jogról* [Unitarian ecclesiastical law of marriage], Gámán János, Kolozsvár, 1889.

girl chosen to be the wife came from a rich family, or was the only child of the family, inheriting the whole property of the father. Since in these marriages, the parties did not know each other, the promise that they will, one day, become attached to each other, did not always come true. At the same time it often turned out that the man chosen to be the spouse was a penniless person, or the girl turned out to be fastidious, lazy, or already pregnant. The end result was the lack of affection, or not moving in together, refusal of sexual relationship, etc. and thus the marriage was deprived of its purpose.

Forcing resulted in the invalidity of the marriage. In accordance with the ecclesiastic law, the faulty or deviant party was the one who did not say the truth, deceived his/her partner and the congregation. This party was sentenced to penitence keeping but also the parents could count on pecuniary fines.

Of the sins related to divorce, the most severe ones are related to sexual life, like adultery and cohabitation. Often existence of illegitimate children proved the commitment of sexual sins. Adultery meant unbalanced sexual relationship outside of marriage. According to the Calvinist marital regulations, the well-founded suspicion of lecherous behaviour in itself was sufficient for a divorce, while the Unitarian Church accepted it only if proven by witnesses, thus it happened at more than one time that the accusations made were only registered as suspicion even if an illegitimate child was already born. Adultery was typical of both men and women, but on the basis of the number of declared divorces, it seems to be only the sin of women. For example, in the Calvinist Diocese of Odorhei, 37% of the divorces, altogether 896, were enunciated due to sexual sins during the 19<sup>th</sup> century. Of these numbers, adultery of the wife caused 470 divorces while unfaithfulness of the husband caused 243 divorces. The explanation for this was that the sexual erring of women was judged more severely (thus these were more monitored) than those of the men, since the adultery of the woman could result in bringing into the family illegitimate children who, should the act of the woman not be discovered, could have become the heir of the family's bread-winner. Persons who committed adultery were considered deviant, the Church could limit their right to remarry, were punished with penitence keeping and excommunication, while the punishment of the secular powers was corporeal, namely flogging, and in more serious cases putting in the stocks, or being tied to pillory.

Cohabitation meant illegitimate living together of the partners without marriage. It presumed both corporeal and emotional relations together with the maintenance of a common farm. Such relationships developed when, for some reason, the married partners who had a fight or moved to a separate address developed new relations without being divorced from their spouse. Though this act also involved the sin of adultery, the ecclesiastic regulations were more indulgent in these cases, and tried to legitimise the relationship and the children who were born. The cases of cohabitation became common during the last three decades of the century among the followers of all the three religions, and the spread of going to domestic service to the Rumanian territories had a significant effect on cohabitation since these illegitimate relationships did not catch the eye in a strange village. Such kinds of relationships were behind those notes in the register of births, which indicated that the mother gave birth to several illegitimate children from the same man. For example in the 19<sup>th</sup> century in the Calvinist community of Eliseni at least 31% of all the illegitimate children were born from mothers living in such relationships. In the Reformed Diocese of Odorhei, between 1801 and 1895 concubinage of women caused 80, and that of men 103 divorces. In the Unitarian community of Cristur between 1801-1895 18.25% of all the illegitimate children were born in concubinage.

Often enough, divorces were declared due to deadly hatred, which could be caused by several types of deviant behaviour (aggressiveness, incredulous life, theft, the neglect of the family and the farm, alcoholism etc.) and sometimes by illnesses or physical problems. In such cases, the Unitarian and Calvinist ecclesiastic forums first declared only temporary separation, 'from table and bed', and then, if the partners failed to become appeased, they were permanently separated.

Quarrelsome, aggressive character could lead to deadly hatred. Swift-tongued behaviour of the woman represented the violation of accepting the decisions of the husband, and thus the questioning of the men's dominance and leading role. Aggression of the husband shall be interpreted from another perspective, since, according to the ecclesiastical laws, with the marriage the men, the husband was given the right to exercise priority rights in the family, lead and govern the family members, with the condition that he should be modest. The respective documents indicate that beating exercised by the parents and the husband was present in everyday life as a tool to educate and guide the wife. In general,

aggressive behaviour and beating are accompanied by other deviant behaviours, like drunkenness, lecherous behaviour and neglect of the farm. Aggression has become the major cause for divorce, if beating endangered the life of the spouse. Such cases were the beating up of pregnant women, or beatings with heavy objects, like rifle, shovel, or pitchfork.

Deadly hatred could be the result of incredulous life, namely missing to visit the church services, not keeping the religious feasts, working on Sundays, but above all, using swear words, which was a violation of the ten commandments. In the first half of the century, those who used swear words were often penalised during the church visits, but such cases disappeared from the records by the second half of the century, since swearing became common and the society got used to it.

The documents on litigations and divorce indicate the existence of two different types of theft. On the one hand, it meant the appropriation of the goods and possessions of others, which became the reason for divorce because this act indicated changes in the nature of the partner, showed that he or she became villainous. However, selling the property and goods of the family by the wife without the consent of the husband, or taking away the dowry of the wife without her consent was also considered theft. At this point we should mention the alcoholics who, in order to have money for their drinks, 'stole' or sold the goods which were part of the family property.

When it comes to illnesses and physical problems, the most common were dermatological problems, short-sightedness, epilepsy, physical handicaps, impotency and sterility. If the illnesses and physical deficiencies developed after the marriage, could result in deadly hatred because the party in question was unable to meet his or her conjugal duties. Those who were ill or suffered from physical problems, handicaps, became deviant if these phenomena were kept secret before getting married, cheating this way the spouse. Venereal diseases proved the commitment of sexual sins. If the illness made the realisation of the core objective of the marriage, namely begetting children, impossible, the Church prohibited these persons from re-marriage until they were recovered from their illness.

The most frequent reason for deadly hatred was the neglect of the family and the farm. Neglecting the family meant the lack of love, and the refusal to care, feed and clothe the family members etc. In general, there were multiple factors lying behind neglect, like forced marriage, lecherous behaviour and the resulting lack of love, which, in some cases, caused

the refusal of sexual relationship. As a consequence, it became impossible to have children, thus the existence of the family became groundless.

Neglect of the farm meant that the husband turned out to be a bad farmer or the wife a bad housekeeper. The Church did not really attach great importance to this phenomenon, unless it endangered the survival of the family. However, the society despised the lavish, lazy persons who did not make their farm and property grow. A number of different reasons can be found behind such behaviour, like alcoholism, forced marriage, lecherous behaviour, ignorance, and lack of practice. The society labelled as bad housekeeper the woman who did not cook, or prepared inedible food, did not like housework, did not wash the clothes, did not clean the house, did not help her husband in the agricultural activities, did not bring food to her husband working out on the fields, could not make bread, did not keep her garden tidy, did not weave or spun. Those men were considered to be bad farmers who spent their time in the pub, spent the family money on alcoholic drinks, did not cultivate the land owned by the family, did not know agricultural work and could not sell the products.

The typical figure of the bad farmer or the bad housekeeper is the drunken person who, instead of caring about and working in the farm kills his time in the pub spending the family money there. Drunkenness was usually coupled with immorality, lecherous behaviour, performing useless activities, like playing the cards and smoking.

#### **4. Summary**

The society of the county was family-centric. The most important moments of individual life were defined by founding of a family. Relations within the family and the society were regulated by the set of values, which developed during the centuries. Of these values, the most important one was common interest and responsibility for each other. Undeniably, the Church exerted a profound influence on the morals and values of the society.

Resistance to the set of values developed by the society and the Church was qualified as deviance and endangered the peace of the community and the proper functioning of the family. Deviant individuals were punished both by the society and the Church. However, the set of values developed by the Church and the society were never the same, and the judgement of certain cases varied accordingly. Observing forced marriages is very interesting. While the Church considered false faith a crime against the

institution of the family, the society considered it as the rightful prevalence, at least to some extent, of the parents' will, thus it was not condemned, because in reality, the parents kept in mind the welfare of their successors, the growth of the common wealth, and common interests. Similarly, in the eyes of the Church, the person neglecting the farm was not necessarily considered deviant, as long as this behaviour did not endanger the subsistence of the family. At the same time, the society despised those men who left their farm to fate and failed to cultivate their land. The explanation for this lies in the fact that the characteristics of the geographical environment influenced the means of subsistence, which affected the roles, expectations and their development within the society and the family. The different categories of sexual crimes: unintentional pregnancies, adultery, extramarital partnership, whoredom etc., were refused and detested both by the society and the ecclesiastic authorities. According to the moral standards of the era, the family was the only venue for sexual relations.

The society lived its everyday life according to the traditional values and change can be witnessed only at around the end of the century. Changes which started at mental level are well illustrated by the spectacular growth of cohabitation during the last three decades of the century and the attitude of the society towards cohabitation. All these changes were motivated by political (for example the revolution of 1848) and economic (for example the Austrian-Hungarian-Romanian tariff war from 1886 and the bad economic situation) factors. One of the consequences of the latter phenomenon was the spread of going to domestic service to the Rumanian territories, which, at least partly, caused the re-evaluation of the social status of women since they became money-earners but also caused the spread of cohabitation because the individuals who went to stay in a different, strange village, far away from the control of the community and the family did not always go home to legalise their relationship. The attitude of the society also changed with regard to these relationships. By the end of the century, the society is capable to accept the cohabitation of the woman who did not as yet brake up her previous marriage, if she is considered to be faithful to her new partner.

This work was supported by a grant of the Romanian National Authority for Scientific Research, CNCS-UEFISCDI, project number PN-II-RU-PD-2011-3-0041.

## References

1. Udvarhelyi Református Egyházmegye Levéltára [Archive of the Reformed Diocese of Odorhei]
  - 1.1. Parciális zsinati jegyzőkönyvek [Protocols of Partial Synods]. 2/1643-1735, 6/1769-1785, 9/1795-1800, 7/1800-1806, 8/1813-1821, 10/1822-1835, 14/1836-1848, 26/1849-1858, 12/1858-1874.
  - 1.2. Vizitációs jegyzőkönyvek [Church Visit Reports]. 3/1718-1721, 12/1780-1789, 11/1800-1811, 15/1829, 18/1838, 22/1841, 25/1843, 19/1842, 20/1846, 21/1852, 23/1854, 17/1859, 24/1860.
  - 1.3. Válóperes iratok [Divorce files]. 1867-1895 (32 packages).
2. Székelykeresztúri Unitárius Egyházkör Levéltára [Archives of the Unitarian Ecclesiastical District of Cristur]
  - 2.1. Udvarhelyi Unitárius Egyházkör vizsgálószéki jegyzőkönyvei [Church Visit Reports. Odorhei Unitarian Ecclesiastic District]. 1795-1802, 1844-1850, 1859, 1863, 1864, 1865, 1866, 1867, 1868, 1869.
  - 2.2. Keresztúri Unitárius Egyházkör vizsgálószéki jegyzőkönyvei [Church Visit Reports. Cristur Unitarian Ecclesiastic District]. 1799-1803, 1804-1805, 1843-1845, 1893, 1894, 1895.
  - 2.3. Udvarhelyi Unitárius Egyházkör alpapi széki jegyzőkönyvei [Reports of the Sub-Ecclesiastic Bench. Odorhei Unitarian Ecclesiastic District]. 1797-1807, 1807-1812, 1813-1838, 1839-1858, 1839-1858, 1886-1895.
  - 2.4. Keresztúri Unitárius Egyházkör alpapi széki jegyzőkönyvei [Reports of the Sub-Ecclesiastic Bench. Cristur Unitarian Ecclesiastic District]. 1852-1861, 1862-1872, 1872-1877, 1877-1887, 1888-1895.
3. Arhivele Naționale ale României. Direcția Județeană Harghita [Romanian National Archives, Harghita County] Colecția registrelor de stare civilă [Registers of civil status]. F 47.
  - 3.1. Odorhei: Reformed community, reg. no. 446, 448, 451, 452.; Roman Catholic community, reg. no. 457, 458, 459, 460, 461, 462, 465, 467, 470, 472.

- 3.2. Cristur: Reformed community, reg. no. 176, 177, 178.; Roman Catholic community, reg. no. 181, 182, 183, 185, 186, 187.; Unitarian community, reg. no. 188, 190, 191, 192.
- 3.3. Corund: Roman Catholic community, reg. no. 155, 156, 157, 158, 159, 160.
- 3.4. Eliseni: Reformed community, reg. no. 225, 226, 227.
- 3.5. Dârjiu: Unitarian community, reg. no. 215, 218, 219.



## Soldier and Civilians Trajectory to Discipline and Resistance

Ittipong Thongsrikate, Kanokwan Tharawan

*Institute for Population and Social research  
Mahidol University, Thailand  
[Ittipong\\_456@hotmail.com](mailto:Ittipong_456@hotmail.com)*

### Abstract

*Soldier and Civilians: Trajectory to Discipline and Resistance with an ethnographic study methodology to learned the culture and ways of life are the factors driving the expression of feelings and behaviors of soldier Discipline happening to soldier housing discrimination continue to block the placement of the positions between space and time appropriately. The daily timetable to practice regulations as central to the soldier in norms that everyone must follow as a result, resistance all forms of void. The knowledge of the military to pass on the way to practice the discourse obscures the scoreboards. When accepted into the body to induce and practice with / without doubt become to behavior habits take this power will always work even if there is little or no control showed that the true power lies in their ability to determined their own governance conduct of conduct. Said that military training for the war was ended with the establishment of a new body human have been transformed into biological assets analytical object. Every type of power has an origin. But, when the process of power moves forward to one point, power will become nameless and no one can occupy it. Power flows and spreads to everywhere in the society. Power, therefore, deems the structure opening various people to take “roles” as active actors and passive actors alternatively. Meanwhile, power does not deprive any rights, but produces many things while resistance exists to keep up such power (Nopporn Prachakul, 2001: 21). The occurrence of new power techniques regarding time management and making time be useful by dividing it into sections, arranging it into a set, synthesizing and processing it into the outcome, which is called the discipline, is the important tool of power to shape people to stay under the same norm. This control is done at the daily life level, and absorbs to humans’ daily activities. This is a large human training process*

*and costs that can be the representative and management in the sense of social and economic. However, discipline should be the location of a particular social institutions created to occupy a manufacturing production and expanded the discourse and power. Military discipline, so it is said because they were soldiers, they have to be disciplined.*

### 1. Introduction

At the “modern” era, Foucault foresaw the phenomena of separation and exclusion, which lead to the establishment of some norms. Others apart from those norms would be placed elsewhere to be altered until they are back to norms or back to normal. These things come from the change of power attributes that go to handle human activities more, either in school, factory, military fort, prison, hospital, etc. Transition to the modern society is a process making humans be the research and

to serve the persons who get advantages from the social system.

Power we have known may be visible or invisible. Power always contains strength. In Foucault’s view, power consists of two sides. The first side is the positive power, triggering good things in the society. This side of power deals with creativity and it is cleaned to be a set of knowledge. Another side of power deals with the control and separation of power and body and/or body and power. Normally, we believe that we can control our body. However, our body may be controlled unconsciously. Foucault explained this discourse that when an individual accepts something, he will be under the power or what he accepts. Accepting an idea or meaning as fact by linking it to one’s body and mind is to allow such power to force himself unconsciously. Thus, power is complicated; it’s not

only the prevalence, but there are also other dimensions relating to body and mind. Foucault calls this as “docile body”.

Power is invisible, but it functions on our body; it's a set of power to manage an individual to stay at the appropriate position. Drill is the impact from power to our body, and one will see how the technology of power acts. The technology of power affects the individual through the set of knowledge, here is the military course, which is intangible but it will become tangible when it acts on human body and the human is transformed to be an object only. Self-power seems the representative picture with discipline, that is, such invisible power will show out clearly when it is viewed through self-power or we dictate ourselves or we permit other people to act under our consent or the power acts on our body under our own acts. Power looks like the weapon forcing other people to do as we accept. Power comes from the individual's inner self.

Military fort is a special area constructed for specific benefits and some duties. The legitimacy of institutional existence depends on the capability of attaining those targets. The military fort is a place of creating or producing the soldiers, from non-commissioned officers to commissioned officers, to have discipline and enable to use their knowledge in the battles. On the road of rooting the discipline among soldiers, “drill” to follow instructions is the most important issue. Drill or creation of discipline in soldiers is based on a well-organized process, which is inserted in bodies of people recruited to be soldiers. Drills are arranged for the enlisted soldiers according to the Military Enlistment Act. Such active soldiers are major manpower of the army, which comprises various units. *This is the drill to transform the active soldiers from civilians to soldiers.* When general people enter into the military fort and/or are trained there, the drills change the civilians' weak bodies to be disciplined ones where the set of military knowledge is flowing all over these new bodies. The discipline in the military fort begins when those civilians are drilled.

## 2. Objectives

1. To study the principle of governmentality (bio-power) among draftees in a military fort.
2. To study the disciplined organization method for disciplined body in type of internal locus of control among draftees.
3. To study the types of resistance to the discipline organizing the draftees' bodies.

## 3. Methodology

The research was conducted by the ethnographic approach. The Researcher was the important tool of data collection by submitting the application to be the draftee at a military fort in order to learn the living there and other draftees' lifestyle. The data collected involved the culture and living encouraging the draftees to express their feelings and behaviors. When the Researcher got sufficient data, it was analyzed, interpreted, summarized or created as the theory to explain the draftees' living under discipline. The Researcher attended all and every step of draftee drills. Mainly, the Researcher had observations when being in field, recorded the observed issues every day, had informal talks, tied relationship with other draftees, asked for draftees' general living, had greetings, interpret the draftees' behavior from messages recorded on their personal notes and from messages the draftees narrating the drills, had informal interviews during the drills, and had in-depth interviews with informants after the drills. The conceptual framework was derived from the review of related concepts and theories. Then, the field data was arranged as an archive, which was classified into sets. After that, the ordered data was arranged subject to the content analysis.

## 4. Results

Governmentality or internal locus of control administration is originated by the state administration in order to control the state's population in good order. Therefore, the state constructs a tool to force the state people to conform to the same standards or norms that are later developed to be laws and many requirements. The single objective is to control or handle individuals' behavior to be in the same direction and live peacefully. The discipline occurs when the people accepts and comply with those obligations until, sometimes, we cannot distinguish whether we conduct by ourselves or we conduct like most people in the society such as Thai society's gratitude, etc. This shows that the individuals are usually occupied by “discourse”, which is a kind of power that most people believe that what mentioned or occurred is the fact, neat and clean, and it is packed in form of knowledge sets transferred by various communication methods. Finally, humans become objects occupied by many sets of discourse, and transformed by social changes. This shows that when humans accept and believe in anything willingly



without careful consideration or they are self-centered, the humans will not be different from the objects. This means that the most terrible weapon does not stay outside, but inside the individuals. This weapon comes from humans that accept anything undoubtedly. Therefore, internal locus of control is more terrible than the missile, which can function any time while humans are actors only.

#### 4.1 Governmentality among draftees

A draftee is a guy whose body is strong, standard, not disabled, has no diseases obstructing military drills, and is at age of 21 and up. These individuals are not created to be the soldiers. They just have the physical structure of guys who have the strong body, are arrogant and patient. Under the state's framework, from past to present, the guys must be soldiers under the main discourse on the nation state deeply rooted up to present. Although, wars, at present, are historical events and may no longer emerge, the state must use the soldiers' bodies to be the national defense. Their bodies are also employed for other social affairs benefiting the economy and politics. The legal process is used to force those guys to be the enlisted soldiers. The military units transform these civilians to be the soldiers by using drills. Various discourses well organized are gradually and systematically inserted into their bodies. The soldiers' living process is blocked and they all must live in a closed area, that is the military fort or an institute constructed to serve some national objectives. The soldiers' acts are limited by conforming to the trainer's instructions only. The sets of knowledge embedded in individuals no longer exist. The forcing process occurs continuously and systematically, especially the management between space and time. A period of 10 weeks contains the repeated conducts until they are partial in life. The military attributes are transferred in forms of training rather than memorizing, accepting instructions, and self-practice. When the individuals believe and accept, the inner silence occurs. The civilians try to conform to the instructions although they may not want to do. Later, these civilians would conduct pleasantly and want to perform what they are trained better, which is an expression before the end of training. The drill instructors will become a component of expression while the actors play roles by themselves. This shows that when the individuals accept whatever until they believe and conduct at everywhere and every time, they will express voluntarily. These acts come from us. This means

that power stays in us, but we have never been aware whether we conduct subject to the instruction or ourselves.

Governmentality deems the power deriving from the power of accepting some factual systems regarding our attributes, and we take such power of accepting those facts in our consciousness and mind to control ourselves (not because we accept that they are righteous). This is the military drill through the sets of knowledge given by drill instructors. At the second level, the governmentality is a technique of power or it is the connection between governmentality and pastoral power. It is explained that the pastoral power is the Catholic priest who takes a role of controlling a flock of sheep. He must sacrifice to take care of this flock and each sheep must survive. It's not only the control, but the ability in caring for the whole community and individuals to have good living and survival. This power may be the power in our conscious mind and such pastoral power is used as a conduct of conduct or this means that the civilians accept that they are transformed to be the soldiers, accept military concepts at the first stage, and implement those concepts strictly while they also accept certain individuals, either drill instructor, drill sergeant, or new soldier instructor. At the third level, the governmentality conceals one pair of conflicts. On one side, the governmentality seems that it makes us to be ourselves because the acceptance of factual power leads to more individualism or individualizing form of power, which includes thought, self-expression, independence, liberty and ability in seeking for new things making the individuals feel that they have freedom. Another side of conflict is the totalizing form of power. It is the factual or casual system controlling us, e.g. religious teaching about Do good, receive good; Do evil, receive evil, or merit and sin, etc. In the green area, although the soldiers must strictly conduct under instructions, the military tradition must be held; for example, line of duty death is the soldier's prestige or soldiers must be the national fence, etc. Accepting such universal concept causes us not be ourselves. Therefore, the governmentality causes some conflicts, that is, we accept the universal power, but we must be ourselves.

It may be said that the governmentality is the conduct subject to individuals' position. It's the conduct of conduct. The conduct comes from the inner self, and the inner power is used efficiently by relying on the disciplined body. The governmentality in soldiers occurs when each soldier accepts a set of knowledge to his disciplined body, and bows the conduct without any conditions or negotiations as he

believes and accepts. Thus, humans are occupied neatly. When anything is accepted and conducted until it becomes one's inner character and/or habit, a variety of behaviors will be shown out, and we can assume who they are. This is resulted by the functioning of internal locus of control. The functioning of internal locus of control also deals with the individuals' shape and behaviors and social institutions. Since 1990, humans' living has been transformed by focusing on the details of conduct rather than the general overview. Military drills for warfare stops in the same time when the new body is established. This is the disciplined body and ready for use. It may be said that, at the present era, this disciplined body becomes the bio-asset and cost that are the representatives and economic and social management.

#### **4.2 Discipline in type of internal locus of control**

The formation of discipline also needs some specific areas or it is called "area blockage" for specific activities like the boarding school where the students must live and sleep there, which is developed from staying at the temple. Apart from some specific areas, there is also the positioning or it is called "squaring". Foucault explains that squaring is to set up individuals at particular positions and each position will be occupied by one person only. Squaring aims at separating the people from each other to prevent their escape. Therefore, the individuals must be placed at each section, which is divided equally. This will help monitor, control and learn about each person's behavior. The discipline area is the compromised area. The value evaluation and supervision are shined on it; so the discipline can establish the "living square" in order to transform humans that are confusing, useless and dangerous to the system to be the classified and well-arranged sections. The "area squaring" arranges the confusion and dispersed variety of individuals to be under the discipline frame. The discipline models may be seen in school, hospital, and temple. This also relates to power and knowledge as both systemize various things, and create the tools to control them. This is to form the discipline for the variation.

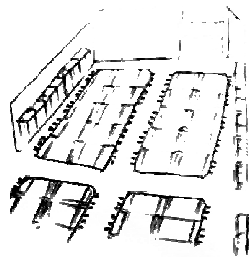
Soldiers are controlled by schedule, SOP. And daily drills. Their time is also divided into several sections. It could be said that, at every drill hour, the controller would manage the drill time carefully. In each hour, there will be the demonstration, testing and practice, making gestures rightly, repairs, etc., which all occur in one hour and must be proceeded

smoothly. Forming a line or running to the drill position is controlled by time; for example, 5 minutes to form the line, 3 minutes in the toilet, etc. Every minute is valuable for the drill while the set of knowledge is rooted into the soldiers who must do everything quickly, and conform to the instructions correctly. In few minutes, they must form the line perfectly based on the drill. The more the controller counts the time, the quicker the soldiers must handle with themselves. Except forming the line, dividing and giving details, the drill gestures are also divided and detailed; for example, uncapping when armed consists of 3 steps, uncapping when armed (object) consists of 7 steps, turning right-left consists of 2 steps, and turning back while walking consists of 3 steps, etc. All these must take time most efficiently. Time must be spent usefully, that is, the more time is divided, the more minor time is added up because time is the most important thing in performing duties, especially the Army's duties. Discipline is equivalent to "squaring" to put individuals into each room. This may be compared with the "operating process", activity arrangements and body control. The operating process, hereby, is the "drill". The drill is the technique of compelling the body to perform duties. The body compelling may be repeated or different up to the fixed steps. The drill looks like the alteration of behavior to meet the target, and the individual attributes can be identified at all time, either they may be compared with the target or with other persons or with the past drill process.

The discipline in the military fort, therefore, is the balance allocation between persons and rules set up. The model is from the Western or cathedral and the principle of Christianity as well as the discovery of great knowledge base on humans in the 19<sup>th</sup> century with a focus on details. The military fort is specifically constructed to perform some duties for the society. The persons living in that area must be under discipline. The most apparent issue in the military fort is the timetable called "standard operating procedure or SOP" that deems the heart of time management for the soldiers' bodies. New soldiers are first framed by the timetable. After that, the conduct will be more complicated. The soldiers will be trained subject to the level of drill difficulty to be inserted in these disciplined bodies. The technique of detail division handles the soldiers under rhythm and time. Therefore, the new soldiers must concentrate on the drills at all time, and they will use their inner power beneficially. Each new soldier will have his own position based on the room preset and 4 following steps:

**Discipline starts from timetable (regarding area allocation)**

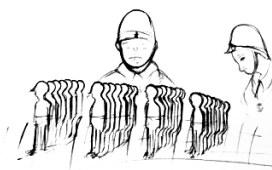
“...soldiers’ barrack is an open-air hall without any curtains or walls. At the front of hall, there is the porch used as the ordnance depot. There are one front door and two doors at the middle of the hall. The soldiers’ beds are arranged in the square shape, which are divided into sectors. The center of the hall is provided for the path, arranged in the plus sign. Each soldier will have his own bed, cabinet and cleansing tools placed neatly at the right place. Each soldier’s shoes are placed, subject to their height, at



the bed end. Before going to bed, all soldiers will be counted by instructing each soldier to stand at his own bed. If no soldier stands at any bed, it means that such soldier takes leave or is absent. After that, the sergeant will blow the whistle and turns off the light before checking up all soldiers by throwing the light to check whether the soldiers sleep or not or cover with the blanket or not...”

**Positioning and activity control (regarding activity setting)**

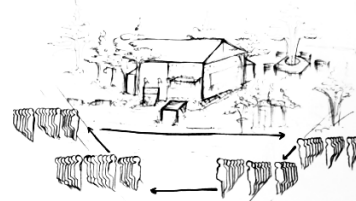
“...when starting the military drill, every soldier must follow the instruction promptly. After the whistle blew to form the line, every soldier must run to form the line quickly based on each soldier’s height. The places of absent soldiers will be left. The line must be straight. The space between each soldier must be equal. The toes must be straight. Each soldier must look at the chest of the third soldier. The body must be straight and lifts the left elbow. While forming the line, there must be no speaking. The face turns to the head of the line...”



**Acting arrangement for the origin source (by time accumulation)** “...to salute while armed, each soldier must stand straight. The right thumb hooks below the front sight of the weapon, and lifts the weapon until the flash suppressor stays at the sight level. The left hand holds the barrel supporting cover. Throw off the right hand strongly. Stand and stretch for 45 degrees at the swan neck, and keep the thumb. The remaining 4 fingers must be arranged closely. Look ahead. Body is still...”

**Discipline comes from strength (Regarding the composition of strength)**

“...the soldiers’ bodies are trained to each duty as required. The new soldiers are trained individually or in group comprising at least 5 soldiers. Each soldier is trained for each step under the counting rhythm. When they are skilled, they will be trained by the open steps, but the counting rhythm still exists. All soldiers are split into 2 groups and turn to face to each other or stand zigzag in order to see the soldiers in front of them. The new soldiers’ positions may be changed at all time. If any soldier has the wrong act, he will be separated for more training, and other soldier will replace. When every soldier conducts skillfully, the whole soldiers will be trained together...”



The above 4 components deem the tools of forming the power through human bodies that are compelled, required, conducted and trained by various steps. It may be said that this is a combination art to enhance the efficient strength. The arranged bodies, preset activities and training for skills from a set of knowledge become the method of discipline formation during the 18<sup>th</sup> century as Foucault said. This disciplined bodies become the valuable bodies for all affairs. They hold some economic and social values. However, Foucault may forget that the discipline also depends on conduct area and time. The discipline in enlisted soldiers means the strict conduct according to the supervisor’s command without any resistance. Therefore, they choose to conduct subject to the set of knowledge as trained in the military area while other areas outside the military fort are their temporarily discipline permitted areas.

### 4.3 Resistance

The green area restricts humans to be objects that must lower to instructions, conduct, and accept them pleasantly or unpleasantly. Every new soldier must accept them implicitly. Everyone believes and adheres to them and it is impossible to reject them. The rejection or resistance will result to the punishment from mild to strong level. The punishment not only makes fear among resisters, but it retains the power. However, this does not mean that there is no resistance. The enlisted soldiers rely on the eased discipline on the relative visit day up to their leave during the drill. This means the military escape as well as behavior expressing that they do not want the drill, e.g. pretending to be sick, not comforting to instructions, facial expression, jumping the queue, food scrambling, etc. Finally, all these resistant behaviors would be remedied by punishment or repair. Thus, the soldiers must be under rules and discipline, and they cannot omit their duties. Prohibitions always remind the soldiers for their life in the green fence. However, those strict rules and/or prohibitions are always broken, evaded or escaped as Foucault said that wherever power exists, resistance occurs there.

The new or enlisted soldiers are under internal locus of control because they accept the discourse containing the set of military knowledge. The soldiers' bodies must be governed by instructions in the drill period. The set of knowledge will be arranged from simple to difficult. Power gradually intrudes until the soldiers feel that the "drill" is normal. This makes the soldiers unable to escape from their bodies. Thus, self without inner identity must accept that power forever. The soldiers will escape from the internal locus of control when one of them uses the consciousness to check or view himself. If he always checks up what those things are and what results are, the body with no self will be changed to be the body with real self. That soldier will be able to control himself by putting the independent thought or this is called "self-master" as he is free to dictate or handle his own life or his living art whereby that enlisted soldier is fully free in himself.

### 5. Discussion

The discipline arrangement in the 21<sup>st</sup> century is the output of the previous knowledge base. The discipline focuses on minor details rather than macro details as previously conducted. Humans are further

treated by the structure of social institutions and social contexts; so they try to escape from this structure by creating their own selves. However, the sociological knowledge base has been tested by science, and it has been more accepted. The research on Soldiers and Civilians: Trajectory to Discipline and Resistance focuses on the governmentality, which is another facet of modern power regarding the power inside humans. From the research, it was found that, in fact, power exists everywhere and at every sector of the society. Humans are covered by current power or knowledge and information that spread so quickly. But, the last decision is at humans who will choose to believe and conduct subject to what they accept unconditionally or not. They have conducted repeatedly until those conducts become their habit although no one compels them. These rules are defined in the mind. Foucault tries to point out the linkage between power, knowledge and micro discourse and macro discourse. He views that the discourse formulates knowledge, and it establishes the power for various institutions of the state. These institutions utilize the power of discipline under various discourses to classify, separate and formulate the discipline training for the members for the best benefit. The control is done via watching, checking, and rooting the discipline until the persons watched or controlled conduct by self-control. Such power structure is developed to be the governmentality system where the power is connected from state to individuals. All things are done to be "normal" without the occurrence of questions or resistance. This is a technique of power in the modern society. While every social institution forms its discipline, the military fort as well. The allocation between area and time is a good tool of rooting the discipline. It is like placing individuals on their own rooms and using these disciplined bodies cost-effectively by inserting many sets of knowledge continuously. Therefore, the enlisted soldiers learn from practice in the military fort. However, the intensity of military conduct may be changed when the location changes.

In every atom or particle of atom on this world, it comprises rules and manners of *Idappaccayata*. This condition is the most important one, that is, it is not others, but it is like this and it will be like that. Soldiers will not be the soldiers if they are not trained and given the military knowledge. Humans are still the objects existing composed by elements to be the natural body with no learning. But, when humans are trained for various things, humans become the civilizing persons. Whatever knowledge input will give the same result. We sow the bean, so we get the

bean. The civilian individuals inserted by the military knowledge will get the military knowledge. Idappaccayata is to indicate that, by this cause, this thing happens. On another side, when humans are born, they are named and brought up by rules and social value until they feel that they have their own body and mind; so they have self and unique identities. But, if considering deeply, our self and identities are under the frame, rules and social contexts where we are born and grow up. In fact, we have never been the independent people with free intent as we always hear from the motto of liberal democracy. If we try to break to the social frame, we may find that staying as the out-of-box person will be controlled and pressed by the society while the persons closest to us are the society's representatives. From the above example, it shows that our life and body, in the abstract concept, are subject to the rational theory and imagination on many things in the nature and the society. These things are just causes and reasons, not the actual and stable self. Humans have never been the great persons with free intent. Free intent will occur when we understand the imagination of cause and reason, and absolutely enter into the ultimate truth only; otherwise we will follow the imagination of cause recognition only.

## 6. Recommendations

1. According to Foucault's sight, based on this compelling technique, a new object is emerging and replacing the existing body with the characteristic of machine. The existing body consists of matters and dynamic energy, which is the body image occupying anyone who dreams to see the perfect discipline. This new object is the natural body containing strength, and is the location of continuity. It's the body ready to perform many acts required subject to the sequence of time, internal conditions, and separated components in the body. The new form of body becomes the goal of this new power; it supports the use of new knowledge. Such kind of body becomes the target of training rather than the physical studies that are useless. This kind of body is manipulated by power; it does not move by one's spirit. This body is ready to be trained for benefits, not for rational mechanism. However, in the body with such qualifications, some natural conditions and duty obligations exist. This means that the soldiers' trained bodies are not their old bodies, but trained to insert the discipline into them. The soldiers become the robots responding to any instructions at that place. Although the individuals' existing bodies exist,

they cannot do what they wish because the coercive drills build so high wall that the individuals cannot jump over it. The closed area like military fort seems coercive; so humans there become a kind of object.

2. Although the coercion and discipline training in the military fort change the individuals to have the same standard under the limited time under the strong and powerful process; the functioning of power in individuals does not run. This means that what happens is the acting when the camera is shooting. But, the camera does not function or functions sometimes. Therefore, time is important as it makes the functioning of internal locus of control clearer. Above all, when the nation explicitly requires the working for the military service that the "body" of a male person at the full age of 21 years must report to be the enlisted soldier at the location his name is listed. Every Thai man must pass this process as required by law. By this national frame, all Thai men, how extent they are different, must comply with this law inevitably. The national process must be done continuously. The recruiting of soldiers must be done with no doubts or queries from any men. It is a compulsory duty, and this may be a kind of invisible power, but its outcome may be noticed suddenly, especially the changed body, either visible or invisible.

3. The discipline emerging in individuals having the military training, in fact, is something they have previously conducted, but they may forget them. The persons passing the military training, therefore, are trained by the same matters they have conducted earlier, but the intensity of time and duty conduct are added until they become the individuals' habit. This habit will be further conducted or not, which depends on the internal locus of control in each person. It may be said that the conduct is alternative up to each one's position or place and time, which may be differently intense. The conduct still exists in those enlisted soldiers.

4. Although the intensive and powerful drill process for soldiers may change the old bodies to be disciplined ones, the individuals' inborn trait or habit may be slightly or greatly different. Being the enlisted soldiers is a short period of role playing if compared with the existing environment of individuals. The existing self-being of these individuals is more prevalent than the new bodies molded in the military fort. However, if any

individuals choose to take good things back, the functioning of power in the old body must disappear.

## 10. References

- [1] Anan karnjanapun. (2009). *Think Michel Foucault. Think of something critical. From discourses of repetitiously to print the turning point of the ego*. 1 Chaing Mai University Press.
- [2] Bourdier,P.(1977).*Outline of Theory of Practice*, Cambridge : Cambridge University Press.
- [3] Foucault,Michel.(1970). *The Order of Things: An Archeology of the Human Sciences*. London: Tavistock Publications Limited.
- [4]Foucault,Michel. (1980).*Power/Knowledge: Selected Interviews and Other Writing 1972-1977*.Gordon,Colin(ed.)New York:Pantheon.
- [5] Foucault,Michel.(1984)“*Nietzsche,genealogy, history,*” *The Foucault Reader*, edited with Introduction by Paul Rabinow. NewYork: Pantheon Books.
- [6] Foucault,Michel.(1977). “*The Subject and Power*”,in *Michel Foucault: Beyond Structuralism and Hermeneutics*. Dreyfus,Hubert L.and Rabinow,Paul(eds.)Great Britian : The Harvester Press.
- [7] Foucault,Michel.(1991). *Discipline and Punish : The Birth of Prison*.Sheridan,Alan (trans.)New York : Penguin Books.
- [8] Lrving Goffman,(1990). *Asylums* .New York:Anchor Book pp.4-13.
- [9] Lrving Goffman, (2008).*The Birth of Biopolitics : Lectures at the College de Frence,1978-1979*,ed.Arnold I.Deavidson,London.
- [10] Majia HolmerNadesan.(2008).*Governmentality, biower,and everyday life*,Routlede studies in Socail and Political Thought,No.57,New York and Londol.
- [11] Nopporn Prachanukul .(2011). “*Intro to*” in *Michel Foucault Docsci Body*(Thongkon Prokatma.Interpret). Bangkok khobfai.
- [12] Rizvi,Ali.(2012). *Freedom, Power and Capitallis: From Disciplineat to Biopower*.pakistan business review research paper.
- [13] Rose,Nicholas.(1993).*Towards a Critical Socilogy of Freedom*.luaugural Lecture delivered on 5 May 1992 at Goldsmith College University of London,Goldsmiths college.Occasional paper.
- [14] Sayphin Suphuthamonkon.(2543). *The prison with people: power and resistance*. type II 2 Bangkok:Thammasat University Press.

## The Relationship of Academic Self-Regulation of Secondary School Students with their Academic Achievement

Dr Abid Hussain Chaudhary<sup>1</sup>, Aqila Rafique<sup>2</sup>, Amna Yousaf<sup>3</sup>

<sup>1</sup> Professor and Chairman of Secondary Education Department in IER, <sup>2</sup> Ph.D scholar University of the Punjab, Lahore Pakistan, <sup>3</sup> Ph.D scholar University of the Punjab, Lahore Pakistan, <sup>a</sup> chabidhussainier@yahoo.com, <sup>b</sup> aqilarafiq@yahoo.com, <sup>c</sup> amnayousaf94@yahoo.com,

### Abstract

*Self-regulation has been described as 'the process whereby students activate and sustain cognitions, behaviors, and affects, which are systematically oriented toward attainment of their goals' (Schunk & Zimmerman, 1994). Self-regulation is a broad concept covering a number of interdependent aspects. There are different aspects of Self-Regulation like academic, cognitive and emotional. The present study was aimed to determine the relationship between academic self-regulation of the secondary school students with their academic achievement. It was a Descriptive type of study comprising a sample of 222 secondary school female students selected by convenient sampling. The instrument "Academic Self-Regulation Questionnaire (SRQ-A)" was used for data collection. Academic scores of the students was used to find out the relationship with the students' beliefs about academic self-regulated learning. Correlation was applied to find out the relationship between the variables and to analyze the data.*

### 1. Introduction

Students should have the ability to self-regulate themselves (Matuga, 2009). For the learning process self-regulation is vital. It is helpful for the students to demonstrate better conduct in the learning process as well it reinforces their academic skills (Zumbrunn, Tadlock, & Roberts, 2011). Shih (2002) says that there are varied definitions of Self-regulated learning on the basis of different theoretical frameworks. Generally self-regulated refers to "the process whereby students personally activate and sustain cognitions and behaviors systematically oriented toward the attainment of academic learning goals" (Schunk, 1991).

Pintrich (2000) has defined the self-regulation learning as it is a dynamic and productive process which motivates the learner to set their goals and according to these set goals makes them to regularly observe and control their performance. Honorio, Calixto, Antonio, and Purificación (2010) has presented a definition of self-regulated learning developed by Zimmerman (2008) as "those self-governing processes and self-beliefs that facilitate the student's transformation of mental abilities into school-performance abilities."

As self-regulated students have high motivation level and they are able to be familiarize with the methods of learning more effectively so they are more successful in their academics and also they are more positive and hopeful towards their future (Zimmerman, 2002).

Chen (2002) argued that the academic achievement of the students is remarkably related to personal competencies of the students. These competencies make the students as self-regulated learners who govern themselves. It is equally important for the teachers and students as well to comprehend the notion of self-regulation in order to develop such competencies.

Self-regulated learning as defined by Zimmerman & Risemberg (1997) is a "self-initiated action that involves goal setting and regulating one's efforts to reach the goal, self-monitoring (metacognition), time management, and physical and social environment". It refers to self-generated thoughts, feelings, and behaviors that are concerned with the accomplishing goals (Zimmerman, 2000).

Klassen (2010) identifies that the students who are successful in their academics regulate their achievement by setting goals, emphasizing on the challenging tasks, effectively managing their time and assignments and by using successful learning

strategies. Academic self-regulation calls for understanding of learning strategies, the competency to involve in these strategies, and the motivation to persevere with the strategies even during difficulties (Klassen, 2010). Zimmerman (2001) discusses that academic self-regulation is the process that is self-directed. In this process the learner intends to transmit their cognitive skills into academic ones. Moreover it involves making the learners as “metacognitively, motivationally, and behaviorally” self-active in the entire learning process.

Dugan and Andrade (2011) have declared that there is so much research has been conducted but the area of the concept of academic self-regulation is not so much clear. They confirm this by quoting the works of other researchers like Boekaerts, de Koning, & Vedder (2006); Boekaerts, Pintrich, & Zeidner, (2000); Zimmerman (2001) that somewhere academic self-regulation is considered as a skill, sometimes a will and sometimes as regulation of learning.

There is a relationship exists between self-regulated learning and high academic Achievement (Zimmerman & Martinez-Pons, 1992).

Schunk (1993) has also viewed that those students who have the ability to self-regulate their learning are more successful in terms of their academic performance as compared to those who have low level of self-regulation. Butler and Winne (1995) express that “self-regulated learners begin with a given task; evaluate the task and set goals according to the information from the evaluation; use strategies to meet the goal; monitor their progress toward the goal and evaluate the use of the strategy; and reinterpretation of the task takes place regarding information attained from internal and external feedback”.

There are some thrilling findings as described by Zimmerman (2001) regarding the nature and emergence of how students regulate themselves. Zimmerman (2002) has discussed that the by self-regulating themselves the students can reimburse their learning differences. It is also helpful in explaining the academic self-regulation. Students can also express the organization and working of the process of self-regulation. Moreover they are also able to provide an expression of the ways that how they can guide themselves for learning.

Cobb (2003) identifies that self-regulated learners tends to be confident, industrious creative towards the completion of their academic responsibilities and tasks. They are clear about to accomplish their goals what types of skills they have

to be mastered and what is the right way to utilize these skills appropriately.

Schutt (2009) has presented the “three-phase self-regulation model” developed by Zimmerman. He predicts in this model that self-regulation is a cyclical process which involves three phases of learning process; the forethought phase, performance control and self-reflection. In the first phase the learner intends to set the goals and social adaptation. In second phase the learner tries to analyze his performance by evaluating the performance of other learners and also govern himself to approach learning and the third phase is concerned with the learner’s self-evaluation and feedback.

## **2. Purpose of the Study**

The general aim of the present study was to find out the secondary school students’ self-regulation in their academics which is Academic Self-Regulation in relation to their academic achievement. This study addressed the relationship between academic self-regulation behaviors of the secondary school students and their academic performance.

## **3. Population and Sample**

Population of the study was included all the secondary school students. By using convenient sampling technique 230 students were selected as sample of the study who were studying at 10<sup>th</sup> grade in the local Public school. Due to some reasons 222 students participated. Due to time constraints and summer vacations the sample is only delimited to female students.

## **4. Instruments**

The instrument which was used to collect the data was Academic Self-regulation Questionnaire SRQ-A. This questionnaire concerns the reasons why children do their school work, class work, answer to hard questions and do well in the schools. These are four basic questions that address total 32 items in the questionnaire. This scale was developed for students in late elementary and middle school. The instrument measures four factors that are external regulation, introjected regulation, identified regulation and intrinsic motivation.

It was translated into Urdu for sake of convenience in understanding. Translation was done by subject specialist in Urdu and English, the instrument was validated by taking expert opinion.



Reliability analysis was carried out to determine the value of Cronbach alpha. Its value was .849 which is highly reliable.

## 5. Data collection

Initially 230 questionnaires were distributed among students, however only 222 questionnaires were worth using, so only these were included for data analysis. The data gathered through the questionnaire was about academic self-regulation. In order to correlate this data with their academic achievement, the marks of students attained in the previous grades were used. Percentage of the scores was then correlated with the data.

## 6. Data analysis

Data was analyzed in order to find out relationship between academic self-regulation and academic achievement of students studying at secondary level. Pearson product correlation was used to find out relationship between both variables.

Table 1. Relationship between academic achievement, self-regulation, and its sub-factors

	N	r	
ASR and AA	222	.048	.474
ER and AA	222	.093	.167
IntR and AA	222	-.009	.899
IdR and AA	222	.090	.181
IM and AA	222	-.008	.903

p > 0.05

It is evident from the table that there was a positive but moderate correlation between academic self-regulation and academic achievement ( $r=.048$ ,  $n=222$ ,  $p<.05$ ). It is also clear from the table that there is strong positive relationship between external regulation and academic achievement, sub-factor of academic self-regulation ( $r=.093$ ,  $n=222$ ,  $p<.05$ ). The table also shows that introjected regulation is negatively correlated with academic achievement ( $r=-.009$ ,  $n=222$ ,  $p<.05$ ). The table also clarifies that there is positive relationship between identified regulation and academic achievement ( $r=.090$ ,  $n=222$ ,  $p<.05$ ). While the table also indicate weak negative relationship between intrinsic motivation and academic achievement ( $r=-.008$ ,  $n=222$ ,  $p<.05$ ).

## 7. Discussion and Conclusion

The results indicate that academic self-regulation is interconnected with academic achievement. Two sub factors (introjected regulation and intrinsic motivation) have negative weak relationship. Many factors can be the reason of this low relationship. e.g. inappropriate responses as respondents give socially acceptable answers.

Additionally to this it is also evident from study that other both sub-factors (external regulation and identified regulation) of academic self-regulation have strong positive relationship with academic achievement. It is obvious, as many researches have proved that external or classroom environmental factors have positive impact on academic achievement of students.

With the help of above mentioned results it can be concluded that academic self-regulation is associated moderately with academic achievement. The study was delimited to Lahore district only, so it is assumed that further studies can have better results with larger population and sample. Present study was focused only on examining relationship between academic self-regulation and academic achievement; results could be more helpful if further studies consider other factors as gender, age and class level.

## 8. References

- [1] Chen, C. S. (2002). Self-regulated Learning Strategies and Achievement in an Introduction to Information Systems Course. *Information Technology, Learning, and Performance Journal*, Vol. 20( 1), Spring 2002. Retrieved from <http://www.osra.org/itlpj/chenspring2002.pdf>
- [2] Cobb, R. J. (2003). The relationship between self-regulated learning behaviors and academic performance in web-based courses. Online Doctoral Dissertation: Virginia.
- [3] Honorio, S. P., Calixto, G. B., Antonio, F. C., & Purificación, S. V. (2010). Self-regulated learning, self-efficacy beliefs and performance during the late childhood. *RELIEVE*, 16( 2), p. 1-18. Retrieved [http://www.uv.es/RELIEVE/v16n2/RELIEVEv16n2\\_4eng.htm](http://www.uv.es/RELIEVE/v16n2/RELIEVEv16n2_4eng.htm)
- [4] Klassen, R. M. (2010). Confidence to manage learning: the self-efficacy for self-regulated learning of early adolescents with learning disabilities. *Learning Disability Quarterly*, Vol. 33(1) Winter 2010. Retrieved <http://connection.ebscohost.com/c/articles/48842494/>

confidence-manage-learning-self-efficacy-self-regulated-learning-early-adolescents-learning-disabilities

[5] Matuga, J. M. (2009). Self-Regulation, Goal Orientation, and Academic Achievement of Secondary Students in Online University Courses. *Educational Technology & Society*, 12 (3), 4–11. Retrieved [http://www.ifets.info/journals/12\\_3/2.pdf](http://www.ifets.info/journals/12_3/2.pdf)

[6] Pintrich, P. R. (2000). The role of goal orientation in self-regulated learning. In M. Boekaerts, P. R. Pintrich, & M. Zeidner (Eds.), *Handbook of Self-Regulation* (pp. 631-649). San Diego, CA: Academic

[7] Dugan, R. F. & Andrade, H. L. (2011). Exploring the construct validity of academic self-regulation using a new self-report questionnaire; the survey of academic self-regulation. *The International Journal of Educational and Psychological Assessment*. Vol. 7(1), April 2011. Retrieved <https://sites.google.com/site/tijepa2012/articles/vol-7-1>

[8] Schunk, D. H. (1991). *Learning theories: An educational perspective*. New York: Macmillan.

[9] Schutt, M. A. (2009). Examination of academic self-regulative variances in nursing students. Online Doctoral Dissertation: Alabama. Retrieved <http://etd.auburn.edu/etd/bitstream/handle/10415/1610/M%20SCHUTT%20DISSERTATION.pdf?sequence=1>

[10] Shih, S. (2002). Children's Self-Efficacy Beliefs, Goal-Setting Behaviors, and Self-Regulated Learning. *Journal of National Taipei Teacher's College*, Vol. XV (Sep. 2002) 263-282. Retrieved <http://Fncuir.lib.nccu.edu.tw>

[11] Zimmerman, B. J. (2001). Theories of self-regulated learning and academic achievement: An overview and analysis. In Zimmerman, B. J. and Schunk, D.H. (Eds.), *Self-Regulated Learning and Academic Achievement: Theoretical Perspectives* (2nd ed.) (pp. 1-37). Mahwah, NJ: Lawrence Erlbaum Associates.

[12] Zimmerman, B. J. (2002). Becoming a Self-Regulated Learner: An overview. *Theory into practice*, 41( 2), Spring 2002. Retrieved <http://commonsenseatheism.com/wp-content/uploads/2011/02/Zimmerman-Becoming-a-self-regulated-learner.pdf>

[13] Zimmerman, B. & Martinez-Pons, M. (1992). Perceptions of efficacy and strategy use in self-regulated learning. In D.H. Schunk & J. Meece (Eds.), *Student perceptions in the classroom: Causes and consequences* (pp. 185-207). Hillsdale, NJ: Erlbaum.

[14] Zimmerman, B. J., & Risemberg R. (1997). Self-regulatory dimensions of academic learning and motivation. In G. D. Pyle (Ed.), *Handbook of academic learning: Construction of knowledge* (pp.105-125). San Diego, CA: Academic Press.

[15] Zumbrunn, S. Tadlock, J. & Roberts, E. D. (2011). *Encouraging Self-Regulated Learning in the Classroom: A Review of the Literature*

## **History**

## The manners of Resistance in the Ottoman Popular Literature: The Sample of *Tıflı* Stories

Elif Sezer  
Istanbul Sehir University  
[sezere189@gmail.com](mailto:sezere189@gmail.com)

### Abstract

*The distance between history and literature has decreased thanks to the new philosophical evolutions on textual analysis and the increasing interest in historical studies towards the daily lives of previous generations. Especially the popular literature enables us to reach not only the information on social life of these generations but also the soul of periods, mentalités, as Annales School of History emphasized on. One side of this soul is the resistance of folk against the authorities in different manners. In this paper, I will use the paralellism between carnivals and folk literature that was drawn by Mikhail Bakhtin in terms of the displacement of hierarchical structures. I will investigate the resistance points against the authorities of the regime, of the moral norms and of the elite culture in Ottoman major culture over Tıflı stories which were written in 18th, 19th and 20th century anonymously.*

By the effect of Annales School of History and the increasing interest in ordinary life, historians have become more concerned about the *mentalités*, the soul of periods of a certain society rather than great wars, majors changes in economics and politics and huge transformations in the elitist social environments. This soul of periods is mostly searched from the autobiographies and first person singular narrations because of the special emphasis of New Historians on the ideas, emotions and life style of the individualized ordinary man. For the societies lack of the first person singular narrations, literature comes into play because of its character of involving detailed information about daily life. Also considering the modern philosophies on history which claim that every text is actually a kind of narration, the distance between history and literature decreases in this way.

As one of these narrations, *Tıflı* Stories were written in the 18th, 19th and 20th centuries as nine fundamental stories and their versions. They take this name from a storyteller in the time of Murad the 4th whose name was *Tıflı* and who he is a secondary character in all of the stories. The writers of these

stories are unknown and their styles of printing vary as lithography, typeface and press, spreading three centuries.

By avoiding from the long-standing discussions in Ottoman literature studies about the category of these stories I will see *Tıflı* Stories as a part of popular literature but will be using the term 'popular' in a more complex and complicated way rather than the common usage. Gilles Deleuze&Felix Guattari advocate that 'popular literature' can not be thought without 'minor literature': "What is a marginal literature?" and 'What is a popular literature, a proletarian literature?' The criteria are obviously difficult to establish if one doesn't start with a more objective concept that of minor literature. Only the possibility of setting up a minor practice of major language from within allows one to define popular literature, marginal literature, and so on. Only in this way can literature really become a collective machine of expression and really be able to treat and develop its contents."<sup>5</sup> Minor literature doesn't mean the production of people who are few in number but being on the margins of the major literature which is produced by the major culture. Therefore, everybody can be marginal with his/her one side as a woman, as a child, as a muslim, as a non-muslim, as a villager, so on and so forth.

Although they are the production of Turkish-Muslim culture, *Tıflı* Stories should be seen as a part of minor literature because of their marginality in the major literature with their usage of language, their realist narration about the current daily life, their plots different from the classical Turkish literature and their passive resistance against different authorities that can be seen as bits and pieces hidden among the stories. In this paper, I will investigate the different manners of resistance in and against the authorities such as the authority of the regime, the

---

<sup>5</sup>Gilles Deleuze&FelixGuattari, *Kafka: Toward a Minor Literature*, (London: University of Minnesota Press, 2003). p.18-19.

authority of morality and the authority of elite culture.

### Relationship with the Authority of the Regime

Almost all of the stories that we have a chance to read<sup>6</sup>, nine fundamental stories and their versions, start with the compliments towards Murad the 4th and his time. The language in these parts is redundant to give a feeling of seriousness and ostentation such as:

*"Kıssa-guyan(-i hikmet-)şinas, raviyan-ı fazilet-iktibas şöyle rivayet ve bu yüzden hikayet ederler ki sultan-ı selatin-i cihan ve hakan-i havakin-i zaman, cennetmekan, firdevs-aşiyân Gazi Sultan Murad Han 'alyh-ir-rahmet ve-l-gufrân hazretlerinin zaman-i eva'ilinde..."(p.167)*<sup>7</sup>

However, these beginning parts become contradictory with the rest of the story in which the Sultan himself is a character of the stories. He disguises as an ordinary man and gets into the crowd mostly to amuse himself. In this point, we should remember the Mikhail Bakhtin who sees a parallelism between medieval carnivals and folk literature. Change of clothes and roles in carnivals make the hierarchical structures disappear as a common case in most of the folk stories. Bakhtin explains it as such: "The suspension of all hierarchical precedence during carnival time was of particular significance. Rank was especially evident during official feasts; everyone was expected to appear in the full regalia of his calling, rank, and merits and to take the place corresponding to his position. It was a consecration of the inequality. On the contrary, all were considered equal during carnival...People were, so to speak, reborn for new, purely human relations. These truly human relations were not only a fruit of imagination or abstract thought; they were experienced. The utopian ideal and the realistic merged in this carnival experience, unique of its kind."<sup>8</sup> So, the Sultan gets in contact with the common society and reborns for a new, purely relations. In this relationships, when his authority which occurs after his identity comes into sight and

the ultimate decision were given by him, even at this time his absolute power can be broken by ordinary people and they say:

*"Aya sultan-ı zaman Murad Han, uyur musun, Allah, bize inayet eyle, bu zalim ne Malta'da ve ne sair yerde, bu kafirenin hapsinde kanarada koyun gibi birer birer gözümüz önünde katlederler, aman ya Rabbi, işimiz sana kaldı, acaba yine kangimizi öldürecek kafire' deyip feryatlar ve figanlar eylediler."*(p.219)<sup>9</sup>

In this way, the reader can think the Sultan who is the foundation of visible authority of Ottoman dynasty as one of themselves and gets a chance to criticize his affairs. On the other hand, Murad the 4th is known by both for restoring the authority of the state and for the brutality of his methods. Therefore, such an image of Murad the 4th both makes the stories more enjoyable and saves the writer from being punished by the present administrators because of the criticisms towards the Sultan.

### The Relationship with the Authority of Morality

To detect the resistance in/against the authority of moral norms is much more harder than the visible authority of the regime. The first difficulty is caused by the different perceptions through morality today and in the time that the stories were written. A modern scholar can easily fall into the trap of interpreting the actions of characters with the norms that are valid for today. Being aware of this danger, we should look at the resistance in/against the authority of moral norms within the context of stories itself by close reading.

For example, homosexuality as a phenomenon that is perceived as a danger to familial and social morality in the modern times, is being told in its natural way. Including the Sultan, the people who have different choices of sexuality are welcomed by the society. Whereas, the 'illegal' relationship between men and women which comes into the sight in the courts are seen as a violation of rule and prevented from the city police.

These courts which are gathered in the houses with young boys and concubines become the spectacle for carnivalesque soul. All of the bodily pleasures play an important role in these courts such as eating and drinking. The detailed description of the

<sup>6</sup>From the transcriptions of David Selim Sayers, *Tifli Hikayeleri*, (Istanbul: Istanbul Bilgi Üniversitesi Yayınları, 2013). The quotations from this book will be given with page numbers.

<sup>7</sup>"Wise and honorable enunciators rumor and because of that they tell stories about the time of the sultan of the world and the emperor of the time, deserver of the sixth stratum of the heaven, Ghazi Sultan Murad Khan, the possessor of mercy and forgiver, his nibs..."

<sup>8</sup>Mikhail Bakhtin, *Rabelais and His World*, (Bloomington: Indiana University Press, 1984), p.10

<sup>9</sup>"Hey! The sultan of the time, Murad Khan, are you sleeping? My God, forgive us, this cruel is not in Malta or another place but in front of the our eyes, they kill them as sheeps day by day, oh my God, this infidel woman kill who for this time?They said that and began to cry."

tables does not just show the enjoyment of characters but also transmits the pleasure to the reader. For example, in the story of *Tayyarzâde*, forty six kinds of food are listed from salads to wines, different fish types to meat dishes and fruits. Also, coffee, water pipe, tobacco and herbal drugs are musts for showing the hospitality of the house owner.

All manners of sexuality are common in these courts although Islam prohibits homosexuality and illegal heterosexual relationships. As another side of bodily pleasure, the scenes related to sexuality is described in all of their details. Especially the story of "Famous *Tıflî Efendi* and *Kanlı Bektaş*" is unique in this sense which is very obscene for a modern reader:

"*Tıflî efendi de bir fasıl edip, avrattır, keyif oldukta, 'kalk beni s.k' diye ibram eyledi. Hemen Tıflî de n'eylesin, elinden ne gelir, dühan çubuğun elinden bırakıp, avrat da uçkurun çözüp bacakların kaldırıp yattı. Tıflî de aygır y.ragin küşat edip butu arasına kaptı koyverdi, sürüş mürüş derken yerleştire kodu...Çün ki ayakları kaldırıp yerleştirmişti, çün ki avrattır gördü ki alet kalınca ve uzunca, hayli tamam, gönünce, beğendi.*"(p.174)<sup>10</sup>

Mikhail Bakhtin explains this existence of bodily pleasures in the folk literature with the term 'degradation'. For him, "degradation" is the lowering of all that is high, spiritual, ideal, abstract; it is a transfer to the material level, to the sphere of earth and body in their indissoluble unity."(p.20-21) However, for the folk literature in medieval Europe, there is a sharper division between religion and bodily pleasures. For example, in *Decameron* stories, although bodily pleasures are praised, people still have to choose one of them, whereas in *Tıflî* stories we face with the characters who make love illegitimately, then perform his ablution and morning prayer. Religious institutions and worship have still importance in people's lives but they don't see a contradiction between being religious and savoring the worldly pleasures. Therefore, the character of *Tıflî* Stories isn't in a double-bind situation like the European medieval character. This places him/her in a more powerful position to transform and reaffirm the religious and moral norms which is the best way of resistance. Effective resistance in/against the major culture becomes possible not by separation or conservation but by reaffirmation of the existing culture with a different manner.

<sup>10</sup>After *Tıflî Efendi* enjoyed a little, the woman said 'get up and fuck me'. What can *Tıflî* do? He left the water pipe and the woman get undressed and laid down by raising her legs. *Tıflî* put his penis between her hinds and started to rub himself. When the woman saw his penis is thick and long, she liked it."

## Relationship with the Authority of Elite Culture

We saw the attitudes of *Tıflî* Stories towards the regime and morality which are involved in an interaction with elite culture. By elite culture, I do not intend the culture of elite but rather as a major culture that is composed by various agents but still has a domination over the ones who position on the margins of itself. Which makes *Tıflî* stories as a part of minor literature is its popularity but also its marginal position in the major dominant culture.

In this culture, there is almost no place for prose first of all. Turkish-Muslim Classical Literature was based on poetry and prose shows itself in more functional narrations such as *tezkires*(collection of biographies), religion and mysticism books, chronicles or letters. Old Turkish Literature studies still depend on the poetry or ostentatious prose today and the stories who has relatively simple language, current realism and worldly issues are ignored, therefore, the grey areas between Classical Turkish Literature and Folk Literature are being sacrificing for the addiction of categorization. For example, *Tıflî* is the person who was one of the nearest guy to the Sultan in the palace so he was in the center of elite literature but despite we do not know the writers of *Tıflî* stories, it is certainly known that *Tıflî* was telling stories like *Tıflî* stories. The mutual nourishment between classical and popular Ottoman literature should be marked as such before going through the points of resistance.

However, the interaction doesn't mean the lackness of domination of the elite culture, but each kind of power in Foucauldian sense creates its own resisters. In *Tıflî* Stories, this power-resistance relationship is in progress with the language first of all. While the dominant culture despises its margins, the frivolity of the popular literature uses humor against the seriousness of major literature. The abusive language that involves slang and swear is used for the purpose of humor that gives pleasure reversely for this time:

"*Sess-i İskender bir fertute, kazan kulbu kaş, rastıklı çilingir yüzüğü sürmeli gözlü, mor patlıcan çekme burun, su duvarı şuhi çehre, maymun götü kırmızı yanaklar, katır tırnağı ağız, sığır böbreği dudaklar, atım atım at benekleri, püskürme ben, karnabahar koçanı gerdan, sığır işkembesi gibi memeler...*"(p.213)<sup>11</sup>

<sup>11</sup>"A looney from the time of Alexander, eye brows like handle of a pot, her eyeliner is like a ring of locksmith, nose like a purple aubergine, her face is like a water wall, her red cheeks are like the

Not just with the usage of simple and abusive language but also with the fundamental phenomenons of classical literature is being played such as the phenomenon of 'love'. The beloved in the classical literature has an idealized beauty and it is inaccessible because of its affections and cruelty. Besides that, the beloved in *Tifli* Stories is both romantically and physically desired. It is mostly a young boy or concubine who is not hard to be reached physically and illegitimate sexuality is approvable with this beloved. Against the seriousness and sublimity of love relationship or anti-relationship more precisely in elite literature, *Tifli* stories which can be seen as a part of folk literature in this sense offer an understanding of love which is more bodily and physically by the degradation process.

In the end of my paper, I should remark that these manners of resistance I talked: the resistance against the authority of the regime, authority of moral norms and elite culture are more convenient for the old litography and typeface printings rather than the new ones who resembles the literature of major culture step by step. David Selim Sayers explains it by the natural development of a genre, but I prefer to think this transformation as related with the weakening of the Ottoman elite culture in 20th century. Therefore the unnecessary of resistance makes these stories to lose its features. I hope looking at the popular literatures in past cultures through the glasses of power and resistance relationship will open the way of new estimations and interpretations about the soul of previous generations.

## References

[1] Bakhtin, Mikhail, *Rabelais and His World*, Indiana University Press, Bloomington, 1984.

[2] Deleuze, Gilles and Felix Guattari, *Kafka: Toward a Minor Literature*, University of Minnesota Press, London, 2003.

[3] Sayers, D.S. *Tifli Hikayeleri*, Istanbul Bilgi University, Istanbul, 2013

---

back of a monkey, her mouth is like a hinny nail, her lips are like kidneys of a cattle, spots of a horse and freckles, his neck is like a stem of a cabbage, her breasts are like a belly of a cattle..."

# Interpreting Erotic Sculpture of India

Srishti Singh, Rakesh Choudhary

*Department of Ancient History and Archaeology, University of Lucknow, India*

*Department of Social Work, University of Lucknow, India*

[Shree4uaindri@gmail.com](mailto:Shree4uaindri@gmail.com), [Rakeshchoudhary1808@gmail.com](mailto:Rakeshchoudhary1808@gmail.com)

## Abstract

*My research examines the difficulties involved in describing, interpreting, and researching Indian erotic art on temples. The artworks I consider were created on many reasons. There are therefore no specific reasons for its sensual rather than sensuous art, no ancient archived documents, available to assist art historians in their efforts to make sense of them. There are only accounts and interpretations, frequently highly differentiated in outlook, offered much later. The approaches commonly adopted in these explanations, which will be summarised, are also often too focused on predetermined questions relating to subjects such as sensuous representation and style on temples, or are too directed towards expressing purely visual qualities in the works under consideration. They are therefore not capable of providing adequate interpretations of the sensuous art of India on temples such as those at Khajuraho (Madhya Pradesh). This research will therefore seek to develop a form of art and architectural historical writing which is less coloured by present-day values and practices and which can consequently demonstrate greater fidelity towards these artworks. The terminology of traditional erotic art historical discourse is simply not up to the task of describing the qualities of sensuous art or standing stones. The research will also analyse the importance played by senses such as hearing and touch in the original physical appreciation and experience of these works. Question that my research explores include relationship of nature and architecture in comparison to that of nature and art. As part of my research it will focus on the origins of architectural form, and on the changing allegorical representations of architecture and the arts.*

## 1. Introduction

If spiritual wisdom, as Indians proclaim, is the sages' gift to the world, then the Khajuraho temple

complex must be the core of India's spiritual heritage. But not a single scholar, researcher, or author that I have discovered so far has ever tried to see these temples through the eyes of the masters who created them. Although much progress has been made in understanding the architecture of the Hindu temple, it would, I believe, be fair to say that the appreciation of the temple sculpture has lagged behind. Many art historians of South Asia have deep knowledge of sculptural forms and styles, but do not set out in detail the basis for their judgments. Then again, although erotic sculpture as a field from the point of view of art history in general is unquestionably dominated by Indian models, the achievements of Indian sculpture here have certainly not been subjected to sustained analysis. This paper is an attempt to discuss the erotic sculpture of Khajuraho in terms that are somewhat parallel to the type of study which is the norm in Western art history.

What I have learned from the scriptures and experienced at the feet of adepts has filled my heart with the conviction that Khajuraho is the place where sacred and mundane merge and the wall between sensuality and spiritual ecstasy vanish. This is the meeting ground between human and divine. Here the yogis discovered the purpose and meaning of life and mastered the art of transforming the primitive urges for food, sex, sleep, and self-preservation into spiritual means. They used this sacred site as a laboratory for understanding the dynamics of nature's opposing forces—masculine and feminine, lunar and solar, active and passive—and used that knowledge to master the art of joyful living. And here they guided their followers to build temples that seekers could use as a map for discovering the numberless shrines within themselves.

## 2. Kandariya Mahadev Temple, Khajuraho, 1030 A.D.



Kandariya Mahadev temple at Khajuraho sets the benchmark of Hindu art in India. This temple was constructed in the middle of 11th century when Hindu temples had attained the highest point of matured design. During the period, all kinds of Hindu art including sculpture, music and dance, were intermingled in temple designs [1]. Kandariya Mahadev temple has height about 31 m. It is elevated above a lofty plinth which makes the temple structure sanctity and monumental. The structure is 30.5 m long and 20 m wide, faced to the east to welcome the first rays of sun. The whole structure consists of four major parts-

1. Grbhagriha, i.e., sanctuary where the main deity has been kept.
2. Pradakshina path, i.e., circumambulatory path having three sides' balcony bringing ventilation and light to the interior.
3. Mandapa, i.e., columned assembly hall having two sides balcony.
4. Artha mandapa, i.e., entrance porch.

Kandariya Mahadev temple stands out from other temples of the region due to its grand scale with elaborated building design as a whole and ornamentation. The well-controlled zigzag plan of the temple creates the vertical visual rhythm, accentuated in the elevation through its sharp recessions and projections, whereas the horizontal friezes on the elevation create the horizontal rhythmic growth upward. The most distinctive part of the temple is its lofty curved towers above the sanctuary. It is known as shikhara. Shikhara is crowned by an amalaka, a ribbed circular motif, and a pot finial, known as the kalasha, a sacred pot in which the most precious elixir amrita had been kept. Here in the shikhara, the amalgamation of the form of lotus blossom and that of mountain has been frozen into the form of multiple recursive archetypes. Replicas of the towers are the most distinctive character in the Kandariya Mahadev temple. Like exterior, interior of the Kandariya Mahadev temple is elaborated with ornamentation. At exterior it has more than 646 numbers of figures whereas 226 numbers of figures were sculpted in interior. There is no boundary between interior and exterior in terms of ornamentation and detailing.

## 2.1. Details

The abundance of details in the temple of Kandariya Mahadev not only makes the temple highly fractal in terms of roughness, but also displays the theme of godly beings who are the important characters in Hindu cosmology and philosophy.

Numbers of figures displaying sexual gestures on the temple fabrics symbolizes the creation. In other words, the smallest details of the temple carry the concept of creation. Naked eyes go to the tiniest details up to some level, but the story or the images of the gods makes a passage of spiritual journey for the 'third eye' (power of imagination) to perceive further to the eternity. Though geometrically the details are not the exact repetitions of its parent body of the temple, but it repeats the same concept/ theme of the body.

Tiniest figures give the impression of paramanu (atom), the smallest time unit, the consciousness which acts as the microcosm of the largest time unit, cosmos. Like the exterior, the interior of Kandariya Mahadev temple is also full of figuristic and floral details in which figuristic details protects the sanctuary from demons and floral details depicts the cosmic events. On the ceiling of this temple, the floral pattern of panels is most noteworthy for depicting the cosmos where, again, fractal takes the main role for depiction. Here the combination of some ceiling panels makes the pattern such a way that it seems the flowers are blossomed from buds recursively. From each bud four petals are bloomed then from four petals eight petals are generated and again from this eight petal flower a 12 petal bloom is born. Here the bloom depicts the creation of universe from the lotus bud sprouting from the navel of Vishnu. Each bloom from a single bud is stratified by making the level difference. These differences of levels and concentric floral patterns make a passage for the spiritual journey to the oneness of infinity and thus help the man to practice for getting the ultimate liberation.

Hindu temple is not the abode of God but the form of God and since it was strictly suggested to be the microcosm of cosmos, all Hindu temples have the common basic characteristics along with some unique features. These unique features of Hindu temples, exhibited fractal properties and complex form, act as the signature of Hindu art and architecture. This paper has presented Kandariya Mahadev temple at Khajuraho as the icon of Hindu temples.

Modern architecture lacks fractalness and complexity, and carries the "simple and brute forms." But Jencks believes that there has been a 'paradigm shift' in the contemporary architecture. According to him "*fractals, wave forms and the structure of the cosmos will be resonated with the new buildings*" which indicates the replication of Hindu temples but in a different way.

### 3. Expression in the erotic sculpture

A celebrated art historian and painter who comes close to what SONTAG was getting at might be Ratan PARIMOO (1994) and (2000) [14], who, though he does pay more than lip-service to the importance of authoritative texts, certainly is deeply concerned with the form and practice of sculpture. In his paper, 'Khajuraho: the Chandella sculptor's paradise. Is there a Chandella style of Medieval Indian sculpture? Its sources and characteristics', first published in *Perspectives on Khajuraho*, and then revised in his *Studies in Indian Sculpture*, PARIMOO (2000: 252) [15] stresses his concern with sculptural values, with the rendering of the undulation of the spine, 'of the sensuality ... of the soft feminine flesh'. And he declares that the achievement of the Indian sculptor is 'not "to be put under the carpet"; "preference" should not be given "to the very weighty philosophising on the particular groups of coitus sculptures." Here he no doubt refers to readings such as those of Desai, Rabe, and White, who all refer to the *Silpa-prakāsa*, a text 'discovered' by Pandit Rath Sharma, forger of several other texts.

PARIMOO (2000: 348), I believe, is exemplifying what SONTAG [16] was calling for when he says Khajurāho 'is a paradise conjured up by the sculptor; it is his paradise, it is also the paradise for the aesthetic participant.' His passionate concern to de-scribe the effects of the sculptor's chisel is, I suggest, an instance of the 'erotics of art.' PARIMOO (2000: 348) said, 'Never has a sculptural tradition handled human body with such obsessiveness and complexity as the sculptors of Khajurāho' and 'The Chandella sculptors were truly the worshippers of the female body, as if they too were made intoxicated by the arrows of the Kāmadeva.'

Particularly significant for the purposes of this paper is a remark of PARIMOO (2000: 355) distinguishing between the sculpture of the Lakṣmana and that of the Kandariyā: 'The warm smile and sparkling eyes of the faces from Lakṣmana temple are replaced by a blank expression in the faces of the Kandariya Mahadeva.'

I now propose to look at the erotic sculpture of Khajurāho in the manner that SONTAG

calls for. In the attempt to win back from the textualists a degree of priority for the artist, one is on particularly firm ground in the case of erotic art, since no one has yet found a rulebook for it. Not only does the investigation of the facial expression of the erotic sculpture form a narrowly focussed set among the

many hundreds of sculptured anthropomorphic forms at Khajurāho, it is preeminently in erotic sculpture that people are shown interacting. The Khajurāho sculptures look out-wards, over and above the worshipper; the great majority are individual figures, isolated in their own space, however close to their neighbours. This massed isolation is one of the most remarkable features of the Khajurāho temples, especially in the way that the gods for the most part are not framed in shrines, but rub shoulders, so to speak, with *apsarases* and *vyālas*. The *vyālas* set off the beauty of the *apsarases*. It is also the case, I think, that the gods set off the power of the *apsarases*. The *apsarases* are on an equal footing with the gods, on a one to one basis, and further-more, because they occupy equal space and the gods have crowns, the *apsarases* are actually taller in themselves than the gods.

When Khajurāho first became known in the modern world, through the photographs of Raymond Burnier, Dolly Saher and others, the famous erotic sculptures seemed to represent simply the intense union of the human couple, a union easily transposed to the universal and the individual self.

### 4. Nature and Art

The sculpture of Khajurāho is most famous for its representation of the gaze of lovers, of the longing looks of lovers. We find this even in small-scale lovers, in unemphatic parts of the temples; though not invariably — close together on the upper frieze on the *jangha* of the Visvanātha. What is often noticeable is that in couples the woman looks at the man, but the man looks away from the woman.

Here at this level of life Kama Deva, the god of desire, follows us vigilantly. The Creator has assigned our minds as Kama Deva's abode, and we never know when and how he will shoot his arrows. That is why, while partaking of the celebration of life, we become so distracted, disoriented, and entangled that we forget the higher purpose and meaning of life. During the spring of life, celestial nymphs descend from heaven and make our body, mind, and heart their play-ground. Kama Deva shoots his arrows and we become his victims joyfully. When we realize that we have become the victims of sense pleasure, some of us impose restraints on ourselves and suffer from suppression. Some of us carelessly flow with the current and are swept away by indulgence. The rare ones among us enjoy all the pleasures of the world without drowning in them, for they remain ever-aware of the higher

purpose and meaning of life. How beautifully this state of life is depicted on these walls! Looking through the eyes of those who created these temples, it is clear that this second row of images is a dynamic depiction of the energies that preside over both love and lust, granting either spiritual freedom and fulfillment or sensual slavery and frustration. Where else in the world can you see a portrayal of divine love imbued with purity and devotion side by side with images of unbridled lasciviousness?

At this level of our evolution we know that the force of divine protection is watching over us. Why worry or be anxious? We also know that our personal desires and ambitions are a reflection of the divine will, and we know that all of our actions, no matter how worldly some may seem, are leading us toward inner freedom and fulfillment. This realization helps us live in the world and yet remain above it. Here the distinction between worldly duties and spiritual practices vanishes. In every situation and circumstance of life the upward movement of the soul continues. Propelled by inner joy, it travels upward. The journey beyond this point is represented by the higher parts of the temple, where the designs become increasingly abstract—no personification, no nomenclature. Here we realize how childish it is to think of the divine being as a Hindu god, a Greek god, a Christian god. Seeing the whole structure coming to a point and dissolving into illimitable space, realization dawns: divinity is nameless, formless. It is of its own kind and cannot be described through example, simile, or metaphor. It can only be experienced. The summit is the experience of life in its fullness, and this experience gives us the freedom to explore ever-new dimensions of reality. There is a joyous thrill in encountering the limitless beauty and glory of the infinite. The wisdom intrinsic to the soul spontaneously inspires us to use all worldly resources as a tool to understand the subtle functioning of the reality within.

How many of us really know about the great temple of our body? Is it merely a genetic extension of our parents? Is it just a locus for experiencing pleasure and pain? Is it simply a vehicle for transporting us from the delivery room to the funeral home? Is it the abode of a conscious being that is busy exploring the vast sensory world? Is it simply a vehicle for the mind? Or is it the meeting ground for the individual soul and universal consciousness?

## References

- [1] Mehta R.J. Masterpieces of Indian sculpture. Stosius Inc/Advent Books Division; June 1979.
- [2] Bovill C. Fractal geometry in architecture and design. Boston: Birkhäuser; 1996.
- [3] March L. From sky-scraping to land-hugging. The Journal of the National University of Singapore, special issue The City (10) December, 1992. p. 12–9.
- [4] Ostwald M. Fractal architecture: late 20th century connections between architecture and fractal geometry. Nexus Network Journal, Winter 2001; 3(1).
- [5] Batty M, Longley P. The fractal city. In: Mapelli EG, editor. AD, Urban environments. New York: Wiley-Academy; 2001.
- [6] Mandelbrot BB. The fractal geometry of nature. New York: W. H. Freeman and Company; 1982.
- [7] Thomas D. Architecture and the urban environment: a vision for the new age, 1st ed. Architectural Press; June 2002.
- [8] Jencks C. The architecture of the jumping universe. New York: Wiley; 1997.
- [9] Jackson WJ. Heaven's fractal net: retrieving lost visions in the humanities. Indiana University Press; 2004.
- [10] Steirlin H. Architecture of the world: India. Compagnie du Livre d'Art, S.A.; 1996.
- [11] Michell G. The Hindu temple: an introduction to its meaning and forms. Chicago: University of Chicago Press; 1988.
- [12] Volwachen A. Living architecture: Indian. London: Macdonald; 1969.
- [13] Kumar N. The Hindu temple— where man becomes God. The cultured traveler, 2005; vol.7; December.
- [14] PARIMOO 1994 : Parimoo, Ratan: 'Khajurâho the Chandella Sculptors' Paradise: Is there a Chandella style of Medieval Indian Sculpture? Its sources and characteristics', in: K.K. Chakravarty,

M.N. Tiwari, K. Giri (eds.): Khajuraho in Perspective. Commissioner Archaeology and Museums Madhya Pradesh, Bhopal 1994: 113–119.

[15] PARIMOO 2000 : Parimoo, Ratan: 'Khajurho the Chandella Sculptors' Paradise: Is there a Chandella style of medieval indian sculpture? Its sources and characteristics', in Ratan Parimoo (ed.): Studies in Indian Sculpture (Regional Genres and Interpretations). 2 Vols., Books & Books, New Delhi 2000 in two vols: 344–370.

[16] SONTAG 1967 : Sontag, Susan, Against interpretation; And Other Essays. Eyre & Spottiswoode, London 1967 [Originally published: Farrar, Straus & Giroux, New York 1966. The essay 'Against Interpretation' was first published in Evergreen Review, December 1964].

## Some peculiarities of Roman acculturation of the eastern Black Sea area

Emzar Kakhidze, Merab Khalvashi  
Batumi State University, Georgia  
[e.kakhidze@gmail.com](mailto:e.kakhidze@gmail.com) [m.khalvashi@bsu.edu.ge](mailto:m.khalvashi@bsu.edu.ge)

### Abstract

*The Apsarus example creates significant contrast in relation with another Classical centre of the eastern Black Sea area, Pichvnari, where local population and the Greek colonists used to be in close contacts. Generally, the Romans "coldhearted" attitude with the locals can be observed in other frontier regions of the Empire as well.*

*Naturally, this peculiarity had various reasons. However, we think it important to emphasize the specificity of the Roman state itself and its culture. Unlike Greek civilization, it is more militant, oriented on strategic goals.*

*In the long run, the fragility of the Roman impact became clear after the crisis of the third century AD. As elsewhere in the Black Sea area, the coastal fortification system came to nothing and ceased to function: it had proved to be ill-adapted to local circumstances. New fortified settlements were built inland. The same process is observed at the end of Roman and Byzantine domination, when the coastal strategic points were replaced by internal fortified or ecclesiastical centres.*

*Generally, in the eastern Black Sea area undeveloped Classical enclaves were mostly oriented towards the outside world and could not withstand serious challenges that weakened protection and help from the parent state.*

In spite of the Caucasus was routed by the Roman commander Pompey already in 65 BC, only after Nero who stimulated concentration of Roman military forces in the East, a special, so-called 'Pontic Limes' or Caucasus or Pontus-Caucasian frontier was formed in order to serve the purpose of reinforcement of Roman positions in the Southern Caucasus and to take the region of Northern Caucasus under good control as well [4: 39-44, 152ff]. This was followed by the establishment of strong military bases: Trapezus, Hyssiporto, Apsarus, Phasis, Sebastopolis and Pityus [figs 1, 4; [11: 11-34].

Owing to its favorable location the fort of Apsarus and its surroundings [figs 2-3] are of

particular interest in the study of the relations between Roman and Georgian worlds. The archaeological evidence finds for years give valuable information on the main results caused by the Roman presence within as well as outside the fort, especially on the ways and forms of acculturation. One of the main objectives of the expedition was to study the attitude of the local population, who earlier had adopted Greek and Persian novelties, towards the Roman garrison. That is the reason why we tried to determine more precisely the volume of settlement in Apsarus, its architecture, building types, construction material and location. The determination of the initial borders of the local population settlement was of great importance as well in order to study the further changes of the Roman occupation. Our sphere of interest also included the comparative study of the surrounding settlement with the Roman buildings which might enable us to distinguish common and distinctive elements in architecture and process of reconstruction. At the same time the research of Roman pottery, glass, metal ware and their imitations, coins, etc. was simultaneously conducted in order to determine the degree of acculturation in the south-eastern Black Sea coast and hinterland, lower part of the Chorokhi river and the Adjaristsqhali gorge with its tributaries. We think it of great importance as well to find out whether the Roman political power was spread outside Apsarus and whether it conducted the cultural "annexation" of the region; whether the fields of social life, governance and infrastructure were retained or not; whether their modification or abolition took place; was the local population against new relations or on the contrary, etc.

According to the remains excavated on the ancient site territory and in or outside the fort it becomes possible to trace the pre-Roman and Roman period changes in the sphere of architecture.

According to the remains of the buildings excavated outside the wall in the south-western part, to the left of the central entrance to the fort, nearby territory to the Tower 4 and on the territory of the

ancient settlement site it becomes clear that the most part of the buildings of the local population before the Romans are wooden with a gable roof. For the foundation the construction level was prepared in advance, with a layer of middle-sized or bigger stones. In some places one row is preserved. There are cases where two rows of rather big stones are preserved. Often the smooth-surface samples are used as facing lateral stones. The inner space between them is filled with the mixture of comparatively smaller stones and mud. The maximum height of such type of foundations reaches 40-50cm while the width is 70-80cm on average. The bases assigned for the wooden posts are proportionally set along the full length of the foundation structure. Their size is average 52X46cm. Circular hollows are made in the central part the depth of which is 5-7cm. The number of charred mass as well as iron and scarcely bronze nails indicates that the side walls of the buildings were nailed while the inner space is filled with the mixture of comparatively smaller stones and mud. As for the main walls inner and outer surface, it is covered with plaster. The gable roofs must have been covered with solen tiles. They are numerously found in the fallen mass. However, one or two samples of grooved tile fragments are also found.

As for the floor, it is also made in quite an interesting way. The base is assembled with 15-20cm-wide sand layer while the surface is covered with 5-7cm-deep clay layer. On the floor level the cases of covering the walking path with the fragments of tiles, bricks or other ceramic ware can be observed.

The Romans cease all types of constructions on the outer territory of the fort during the consequent epochs. However, they continue new construction activities inside the fort after smoothing the surface and preparing construction level. Hence, we can simultaneously observe the architecture of pre-as well as post-Roman periods on the same territory, those similarities and differences which were brought and established by the Romans. The traditional Roman architecture in and outside the fort territory utilizes the architectural elements fit for the local geo-climatic conditions. However, the reverse cases are also observed. The local population also adopts some of the novelties which are mainly connected with arrangements of interior, floor or yards of the buildings.

Generally, the Roman construction craft is totally different from the local one. It is especially well observed in *praetorium*, barrack [fig. 5], watch post, water-pipe and draining systems [fig. 6], baths or

other remains. Buildings constructed by the Romans are larger and monumental. They are characterized with rather wide (1.1-1.20m) and deep-rooted foundations. They are erected with bigger stones. Some of them are 1.5m long. The stone layer over them is plastered with clay solution.

Compared to the walls the quads are indented in 20cm. Three or sometimes four layers of stone rows are preserved on the plinth. Smooth-surface samples are selected for the side stones. The inner space between them is filled with the mixture of comparatively smaller stones and mud. In later buildings we observe the cases of utilizing the hydraulic solution. The maximum height of the preserved walls is 1.35-1.40m and the width is 0.90-0.95m. The main parts of the walls are traditionally of wooden material in both local and Roman buildings. The inner space of the walls assigned for garrisons is empty or partially nailed. As for the contemporary local buildings inner spaces they are again filled with the mixture of small, standard-sized stones and mud. It is well-shown by the remains of the later period (3<sup>rd</sup> century AD) buildings on the ancient settlement site. However, in the barrack construction there can be observed such cases when the outer part is faced or covered with plaster or hydraulic solution [13: 28-29]. As for the local population, it again uses plaster for inner as well as outer walls and especially for filling the empty spaces between the logs. As the excavations show, they begin using hydraulic solution after the Roman influence. In both cases the buildings are with gable roofs. solen tiles are mostly met as roofing material. However, in later periods, the cases of using grooved tiles increase both in local and Roman constructions. Stone bases preserved *in situ* might indicate that some of the buildings must have had a pillared hall, e.g. the building designated as the barrack used to have a galley along the whole length to the east. Within the building there are kitchen and dining rooms, grooved-tile collectors, heating systems; sometimes the partition walls are built with solen tiles, etc. The floors are made with hydraulic solution, flagging, ceramic slabs or bricks [13: 10,28,32,33]. The excavated materials show that the local population already adopted the techniques of floor flagging or hydraulic solution. The old traditional forms of putting 5-10cm-thick clay over the sand or stone mass are also frequently met.

Among the already studied buildings in Apsarus the best examples of the Roman construction craft are the remains of a monumental building found in front of the southern gate. It is considered as the barracks

[fig. 5]. It represents a building built with the orthostatic technique. Similar buildings have been found in Nikonion [20: 219], in the village of Dobroe, Crimea peninsula [23: 158], Chersonesos [2: 83; 3: 171], *Kharaks* [8], etc. They are found in the north-western Black sea coast as well, e.g. in Tyra. Here the part of the fallen roof is observed. The walls consist of the foundation-plinth and are built with clay solution. Like Apsarus, bigger stone slabs are used for the foundation. It is built with complex orthostatic technique. The barrack functioned till mid 3<sup>rd</sup> century AD [19: 109-119]. There can be brought other similarities as well but one thing is clear: from the beginning of the 2<sup>nd</sup> century AD most buildings within the Apsarus fort are constructed with the style characterized to the Roman fortifications, though they also used some of the elements traditionally established in the local settlers which proved useful for the Romans as well.

Water-pipe and draining systems of the Roman period are completely different and built with international standards [fig. 6]. They are placed in the general planning of the fort construction. A spring of thick debit in the northern part was used as a drinking water. First of all a large pool was built the facade of which is faced with featured stones while the inner space is plastered. There is no other water reservoir of this period found in Georgia. From the main building three pipes were built which entered the territory of the southern gate of the fort. The inner as well as outer territory of the fort seems to have been ramified with water pipes. It also should be noted that the water supply systems have been preserved in their original state [fig. 6]. In this sense it has no analogy. In general, the Apsarus water supply systems correspond to the ones of a number of powerful centers of the Classical times [13: 38-40]. The remains of the contemporary water supply systems have been excavated in the north and west Black sea areas: Olbia, Chersonesos, *Kharaks*, Panticapaion, Mirmekion, Nova, Potaissa, etc. as well [15: 129; 16: 42-43, fig. 11.1-2; 17: 131; 5: 254; 6: 10: 68, fig. 68; 22: fig. 2]. It should also be noted that the Romans used artesian wells like the local population.

The Romans had arranged the draining systems on international levels as early as 2<sup>nd</sup>-3<sup>rd</sup> centuries AD. In this respect particularly interesting data were accumulated on the territories of the southern gate and the baths. The remains of rectangular collector built with stone slabs have also been determined [fig. 6]. They are made of specially cut white-yellowish stones. This standard slabs may not represent any local types of stones. The walls of the collector are

also built with elaborated stones while at the bottom wooden slabs are laid. The width of the canal is 32cm, height: 45cm. The system similar to sewerage is stated in Pityous (Bichvinta/Pitsunda) which is a century later than Apsarus systems [26: 151, 155-157]. The sewerage system in the Acropolis of Athens is roofed with square slabs like Apsarus [9: pl. 71]. As for the sewerage systems of the contemporary local settlement, they are of comparatively simpler arrangement. They seem to be characterized with two rows of bigger stones. The distance between them is 35-40cm. The bottom and sides are plastered with mud. It cannot be excluded that it was covered with stones from above. It is still unknown if the Roman technique of sewerage systems was adopted by the local population due to the lack of proper material finds.

In the study of the local population relationships with the Romans significant information is given by the osteological finds on the territories of the inner fort buildings used by the Roman soldiers as well as on the so called household section. According to their definition it is clear that among the finds the most numerous were cattle bones. There are bones of goats, sheep, pigs, horses and wild beasts and birds. The local cow was of small size and better adapted to the local natural-climatic conditions. This type of cow is recognized as the genetic inheritor of old-Georgian, old-Colchian small-size cows and is of aboriginal origin.

It is also clear from the determination of Apsarus grain crops that the first place in the soldiers' ration (food allowance) was given to local cereal or beans (soft wheat, rye, hominy, etc.)

Obviously, the most authentic materials on the intensity of Roman-local relations are provided by the archaeological items. The influence of Classical civilization is felt on several items from the famous 1<sup>st</sup>-2<sup>nd</sup> centuries AD hoard [21: 74-76], e.g. 2<sup>nd</sup>-3<sup>rd</sup> centuries AD brown clay vessels, imitations of Sinopean *louteria* [7: 94-95, fig. 53], and three other ceramic ware [13: 54, figs 23-25]. The Romans hardly ever used local amphorae. Only two types of Colchis amphorae of the second half of 2<sup>nd</sup> century and first half of 3<sup>rd</sup> century AD were found in the fort [18: 88, fig. 7.1-2]. It cannot be excluded that they were made in the 2<sup>nd</sup>-3<sup>rd</sup> centuries kiln [fig. 9] found on the household territory [18: pls 3-4].

Ceramic or other types of archaeological objects were mainly imported from the strong centers of the Roman Empire. Moreover, at the first stage of the fort functioning (late 1<sup>st</sup> century – early 2<sup>nd</sup> century AD) the import of western provinces prevailed. It

was only after the settling of the Roman administrative law that the products from Asia Minor appear in the region. However, this fact does not at all indicate the trade relations between the Romans and the local population [14: 315-322]. The opinion that these relations were poor can be confirmed by the researches conducted in Gonio surroundings. Among the Roman import only the small material find by chance from Makho, Satekhia and Makhvilauri and the perfume vessel from Zanakidzebi [24: 52-54] have been known so far.

The Apsarus example creates significant contrast in relation with another Classical centre in the region, Pichvnari. It is known that the local population of Pichvnari and the Greek colonists used to be in close contacts [27: 153-160, 182, 197; 12: 198-205]. Generally, the Romans "coldhearted" attitude with the locals can be observed in other frontier regions of the Empire as well, e.g. in Asia Minor the Greek alphabet and Hellenic names of gods were used till the end of the Roman rule, unlike other regions of the Empire [25: 41-48].

Naturally, this peculiarity had various reasons. However, we think it important to emphasize the specificity of the Roman state itself and its culture. Unlike Greek civilization, it is more militant, oriented on strategic goals which is the issue of another, quite different research, and we are not going to discuss it here.

## References

- [1] Bărbulescu, M. Les principia du camp legionnaire de Potaissa, *Akten des 14. Internationalen Limeskongresses 1986 in Carnuntum* (eds H. Vetters and M. Kandler), 2vls, Wien, pp. 821-831.
- [2] Belov, P.D. and Strzheletskiy, S.F. Kvartali XV i XV (raskopki 1937), *Materialy i issledovaniya po arkheologii SSSR* 34, 1953.
- [3] Belov, P.D., Strzheletskiy, S. F. and Yakobson, A. L. Kvartal XVIII, *Materialy i issledovaniya po arkheologii SSSR* 34, 1953.
- [4] Braund, D. *Georgia in Antiquity. A History of Colchis and Transcaucasian Iberia 550 BC - AD 562*, Oxford, 1994.
- [5] Blavatskiy, V.D. Kharaks, *Materialy i issledovaniya po arkheologii SSSR*, 19, 1951.
- [6] Blavatskiy, V.D. Raskopki Pantikapeya, *Sovetskaya arkheologia* 2, 1960.
- [7] Ebralidze, T. *Samkhret-dasavlet sakartvelos zghvispireti gvianelinistursa da romaual khanashi (savachro-ekonomikuri urtiertobani importuli keramikis mikhedvit)*, 2005, Batumi.
- [8] Firsov, L.V. Izvestkovyy vyazhushiy rastvor v oborone telykh stenakh Kharaksa (Krym), *Sovetskaya arkheologia* 1, 1975.
- [9] Frantz, A. Late Antiquity: A.D. 267-700, *The Athenian Agora* 24, 1988.
- [10] Gaidukevich, V.F. *Mirmekiy*, Warsaw, 1959.
- [11] Gregory, S. *Roman Military Architecture on the Eastern Frontier* (PhD thesis), 2 vols., Amsterdam, 1997.
- [12] Kakhidze, A. *Pichvnari 2: Results of Excavations Conducted by the N. Berdzenishvili Batumi Research Institute Pichvnari Expedition 1967-1997: The Classical World in the Eastern Black Sea Area. The Fifth Century BC Greek Necropolis at Pichvnari*. Oxford and Batumi, 2007.
- [13] Kakhidze, A. and Mamuladze, S. Samkhret karibchisa da abanotubnis teritoriaze 1995-1999 tslebshi tsarmoebuli kvleva-dziebis umtavresi shedegebi, *Gonio-Apsarus* 4, 2004, pp. 4-71.
- [14] Kakhidze, E. Apsaros: a Roman fort in southwestern Georgia, *Black Sea Studies* 8, 2008, pp. 299-328.
- [15] Karasev, A.N. K voprosu o vodosnobzhenii Olvii, *Sovetskaya arkheologia* 7, 1941.
- [16] Karasev, A.N. K voprosu o vodosnobzhenii Olviyskoy gimnasii, *Kratkie soobsheniya Instituta arkheologii AN SSR* 143, 1975, pp. 42-43.
- [17] Karasev, A.N. and Levi, E.I. Olviyskaya agora, *Sovetskaya arkheologia* 4, 1958.
- [18] Khalvashi, M. *Keramikuli tara gonio apsarosidan*, Batumi, 2002.
- [19] Kleiman, I.B. K stratigrafii naplastovaniy rimskogo vremeni v Tire, *Materialy po arkheologii Severnogo Prichernomor'ya* 8, Kiev, 1976.



[20] Kuzmenko, V.I. Issledovanie rimskikh sloev Nikoniya, *Materialy po arkheologii Severnogo Prichernomor'ya* 8, Kiev, 1976.

[21] Lordkipanidze, O., Mikeladze, T. and Khakhutaishvili, D. *Le Trésor de Gonio*, Tbilisi, 1980.

[22] Maevskiy, K. Arkheologicheskie issledovaniya rimskogo naroda goroda Novy (Bolgariya) v 1960 g., *Sovetskaya arkheologiya* 4, 1961.

[23] Puzdrovskiy, A.E. Megarion pozdneskifskogo poselenia u s. Dobroe, *Arkhiturno-arkheologicheskie issledovaniya v Krymu*, Kiev, 1988.

[24] Shalikadze, T. *Gvianantikuri da adreshuasaukuneebis minis natsarmi samkhret-dasavlet sakartvelos zghvispiretidan*. Batumi, 2004.

[25] Svetsitskaya, I.S. *Ranee Khristianstvo: stranitsi istorii*, Moscow, 1987.

[26] Tolordava, V. Bichvintis nakalakariv IV ubani, *Didi pitiunti* 2, Tbilisi, 1977. pp. 145-157.

[27] Vickers, M. and Kakhidze, A. *Pichvnari 1: Results of Excavations Conducted by the Joint British-Georgian Pichvnari Expedition 1998-2002: Greeks and Colchians on the East Coast of the Black Sea*, Oxford and Batumi, 2004.



Fig. 1 Asia Minor and Caucasus



Fig. 2 Plan of the fort of Apsarus and surrounding area

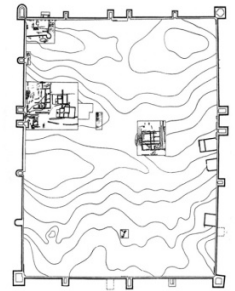


Fig. 3 Plan of the fort of Apsarus

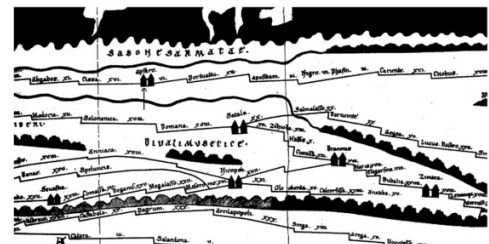


Fig. 4 Apsarus on the Peutinger Table

### LIST OF ILLUSTRATIONS

1. Asia Minor and Caucasus
2. Plan of the fort of Apsarus and surrounding area
3. Plan of the fort of Apsarus
4. Apsarus on the Peutinger Table
5. Barrack
6. Water-pipe and draining systems
7. Kiln



Fig 5. Barrack



Fig 6. Water-pipe and draining systems



Fig 7. Kiln

## **Education**

# Understanding the Educational Impacts of 1-1 Laptop Projects in Elementary and Secondary Canadian Schools

Thierry Karsenti, Simon Collin

*Université de Montréal*<sup>1</sup>, *Université du Québec à Montréal*<sup>2</sup>  
[Thierry.karsenti@umontreal.ca](mailto:Thierry.karsenti@umontreal.ca), [Collin.simon@uqam.ca](mailto:Collin.simon@uqam.ca)

## Abstract

*This study aimed to determine benefits and challenges of 1-1 laptop programs in elementary and secondary school. In all, 2,712 students (from grades 3 to 11) and 389 teachers participated in this study. The results reveal that 1-1 laptop programs have had a major impact on the students, particularly in their skills and competencies (writing, creativity, work methods, communication and cooperation, critical judgment, etc.). The results also highlight how the teachers in this school board have succeeded, through their pedagogical strategies and other teaching activities, in giving technology a central role in the writing process. Technologies have enabled both teachers and students to write better, more, and with more inspiration. Besides the substantial impacts on writing, the results also show the main benefits of using technologies in the classroom, as underscored by the teachers and students: academic motivation, access to extensive information, a wide variety of available resources, the potential for individualized learning, and greater feelings of competence, to name only a few. The implementation of 1-1 laptop programs into education comes with certain problems, however. The two biggest challenges for teachers and students were the equipment and classroom management. This presentation concludes with a list of twelve recommendations.*

## 1. Introduction

In this paper, we present the results of a study conducted from March to November 2012. The research objectives are presented (Section 2), followed by the theoretical framework and the scientific relevance of investigating a “one laptop per child” program and the data collection and analysis methods (Section 3). The results are presented in Section 4. The conclusion is then presented (Section 5).

## 2. Objectives

This investigation had two objectives:

1. Determine the main benefits of ICT for students and teachers
2. Determine the main challenges for students and teachers.

## 3. Method

This study was conducted in a specific setting: the Eastern Townships School Board. Ten years ago, this school board launched a “one laptop per child” initiative throughout all the schools in its district. Over the years, more than 15,000 young people had the use of a personal laptop for the majority of their elementary and secondary school years. This is one of the rare examples in North America where a “one laptop per child” program has been maintained for this length of time (ten years and counting) and on this scale (the majority of students in a school board).

### 3.1. Participants

In all, 2,712 students from grades 3 to 11 and 389 teachers participated in one of the many data collection steps in this study.

### 3.2. Main data collection instruments

Six main data collection instruments were used:

1. Online survey questionnaires for teachers
2. Online survey questionnaires for students
3. Individual semi-directed interviews with students
4. Individual semi-directed interviews with teachers
5. Group interviews with students
6. Videotaped classroom observations.

For purposes of this summary report, we will focus on the first two instruments, the online questionnaires. Each of the two questionnaires (teachers and students) contained 10 sections addressing the research objectives. The questions were selected and adapted from an extensive review of the literature on surveys of educational technologies. The survey had the advantage of being readily accessible by a large number of teachers and students. It proved highly useful for our study, in that we were able to reach a substantial sample of respondents (over 2,700 students and almost 400 teachers).

The protocols for the individual semi-directed and group interviews with both teachers and students included revisiting the question categories from the questionnaires. From the interviews, we gathered the teachers' and students' perceptions of our research objectives. The group interviews were particularly useful in revealing points of consensus and dispute among the participants. They are currently under analysis, and results will be presented in a subsequent report.

As part of this research project, we also observed classroom situations to gain first-hand knowledge of the actual use of laptops in the classroom, as well as the inherent benefits and challenges. We should mention that the analysis of the videotaped observations is ongoing, and the results will be presented in a subsequent report. The present report focuses on the results of the questionnaire responses by the teachers and students.

#### 4. Main results

The main results of the questionnaire responses by students and teachers are presented in this section. Recall that both questionnaires included closed questions, where respondents had to choose from a list of responses, and open-ended questions, such as "What are the two main benefits of the technologies that you have used....?" The questionnaire results are presented as graphics and text extracts. Video excerpts from the classroom observations, available on our website ([etsb.crifpe.ca](http://etsb.crifpe.ca)), will be presented orally during the press conference to illustrate the obtained results.

##### 4.1. Main benefits of using technologies in the classroom

One of the objectives of this study was to gain a better overall understanding of the benefits of

technologies from the standpoints of both teachers and students. Due to their transversal scope, the results reported here on the students' and teachers' responses, based on the qualitative data, end up supporting many of the above-reported results on the impact of technologies on skills development.

The 389 teachers participated in this study reported a considerable number of benefits. The first is student motivation, reported by 19.5% of the teachers, which concurs with the literature:

---

*The two greatest benefits are student motivation and engagement. The students are much more interested in learning new concepts and practicing skills when the lessons are supported by interactive technology. (T3)*

---

Access to information, mentioned by 18.4% of the teachers, ranks second among the benefits. This was considered a major benefit, because information was accessible quickly and continuously:

---

*The greatest benefit is the wealth of information available at our fingertips. It truly is amazing. Students can explore and discover all kinds of knowledge and it is accessible to all. (T4)*

---

The variety of available resources was also a main benefit, cited by 17.3% of the teachers:

---

*As a teacher, I am always seeking to improve my courses, and many of the BBC, PBS and CBC websites provide information, images and videos that I use in my classroom [...] As a teaching resource, the Internet is like having thousands of invisible helpers who provide many options for teaching different subject to different kids in different ways! (T5)*

---

Next, we note the potential to develop individualized teaching (8.9%), recognized as a distinct advantage for both gifted students and students with learning difficulties.

---

*Students are able to have the curriculum tailored to their ability. I am able to use websites for skill development that will adjust to the ability of the student. (T6)*

---

Some of the teachers (7.9%) felt that using technologies in class also allowed them to prepare their students to fully partake in society in future:

---

*It benefits the students to be able to work with technology so as they continue their education they will be comfortable working with technology as well as in their future fields of working. (T7)*

---

Technologies also appeared to facilitate effective work methods (7.6%). This benefit, which some

teachers stressed, is consistent with the above-presented results on effective work methods. As the following extract shows, the teachers viewed technologies as tools that enabled their students to work faster and more effectively.

---

*It is faster to get assignments done on time. There is usually less talking going on, making it easier to concentrate. (T8)*

---

In addition, 7.3% of the teachers reported that their students felt more competent, that is, when performing their assigned tasks:

---

*Also, since the students are so used to technologies in their everyday life it helps them to relate to the material better sometimes. (T9)*

---

On this point, we note that the literature (see [15], [5]) clearly demonstrates that greater feelings of competence are strongly associated with academic success.

Another benefit was the improved quality of the students' assignments (6.6%), as the following teacher explains:

---

*There are many applications which can aid a student in their respective assignments as well, such as [...] visual presentation for a project. It allows students [...] to refine their work and to make sure it is the best they can offer. In many ways, the computer is truly a useful educational tool. (T10)*

---

Greater communication potential (3.6%) and better written work by the students (2.8%) were further benefits that the teachers perceived when technologies were used in the classroom. As the following extract shows, the quality of written work was noticeably improved, in terms of not only presentation, but also ideas:

---

*There is auto correction, which allows you to see your mistakes as you go and being able to learn from them. The Internet provides useful information that students can use for ideas in their assignments or quotes to support their argument. (T11)*

---

When we asked the 2,712 students about the main benefits of using technologies in class, their qualitative responses differed slightly from those of the teachers. The first benefit in the students' view was access to information, with 28.8% reporting that ICT enabled them to access a vast store of information. Like the teachers, the students perceived this as a major benefit:

---

*I could give you 1,000 advantages, but one of the most is you can find your information needed really*

*fast... instead of going in books looking for hours. (S14)*

---

Moreover, 25.5% said that the technologies enabled them to organize their work better. The two following extracts illustrate this perception:

---

*I think that using a computer to do assignments is much more effective than doing it by hand in certain respects for a number of reasons. (S15)*

*Firstly, using a computer, doing the work is much less time consuming due to the readily available information provided by the internet, and not to mention, typing is also much faster. It enables students that are writing assignments that have a word limit and minimum to view their progress as well. [...] There are many applications which can aid a student in their respective assignments as well, such as making a movie or a visual presentation for a project. It allows students the ability to refine their work and to make sure it is the best they can offer. (S16)*

---

For the students, the ability to write "more and faster" was ranked third among the benefits of using technologies (23.8%):

---

*I like using laptops for work at school, because it saves a lot of time, because I can type a lot faster than if I am writing it by hand. (S17)*

---

The students apparently perceived that improved writing was a central benefit of using technologies in class, because "to make fewer mistakes when writing" was ranked fourth (10.3%):

---

*It makes you make fewer errors in writing because the computer is correcting you, so you don't really care about your mistakes anymore. (S18)*

---

This was followed by motivation, which, although only 8.5% of students mentioned it, is nevertheless an important dimension of academic success:

---

*I also believe that using technology makes us students more excited and involve into doing the homework or assignment. (S19)*

---

Although most students did not spontaneously mention motivation, it was obvious that they were motivated when they were observed using technologies in class. The lower ranking given to motivation by students than by teachers could be explained in part by the fact that they experienced this aspect differently. That is, they thought more in terms of "enjoyment." In fact, when the students were asked about how well they agreed with some of the statements about technologies, 94.3% responded that they *liked* using the computer at school, and 94.2% *liked* looking for information on the Internet.



Furthermore, 89.3% of the 2,712 students surveyed felt that using technologies in class *helped them learn*.

Finally, note that teachers as well as students claimed that the use of technologies in class increased feelings of competence (3.4%):

---

*Firefox, Word, PowerPoint, Excel, Garage Band, iMovie, iPhoto, Smartboard. [...] All of these programs help me to learn and to understand what I am expected to do. [...] They really help me in my assignments and for me to have good grades! (S20)*

---

## 5. Conclusion

Let us recall that this project was initiated under a partnership between the Canada Research Chair on Information and Communication Technologies (ICT) in Education and the Eastern Townships School Board. Ten years ago, the education actors at this school board decided to provide each of its students and teachers with laptops for learning and teaching.

In this study, which is still ongoing, we aimed to determine the perceptions of the students and teachers of the impacts of ICT on 1) writing skills, 2) creativity, 3) communication and cooperation, 4) effective work methods, and 5) critical judgment. We also aimed to identify 6) the main benefits and 7) challenges involved in regular use of technologies in the classroom, and 8) the equipment and access available to teachers and students at the school board. In all, 2,712 students (from grades 3 to 11) and 389 teachers participated in the study. We administered a widespread questionnaire survey to students, teachers, and other education stakeholders, the results of which are presented in this report. We also held individual and group interviews and observed classrooms in order to gain a deeper understanding of the benefits and challenges of using laptops for teaching and learning.

First, the analysis of results shows that ICT played an instrumental role in the development of the students' writing skills. They wrote faster, more, and better—in terms of planning and structure—and they enjoyed writing more. Considering that writing is a core competency in the school curriculum—it is deemed essential for academic success in secondary school—it may be concluded that the education actors at the Eastern Townships School Board played a key role by enabling their students to mobilize the cognitive potential of ICT to develop their writing skills.

Second, the results clearly demonstrate the central role of ICT in the development of a diversity of

competencies required for academic success: creativity, communication and cooperation, effective work methods, and critical judgment. Taken together, the testimonies of the surveyed teachers and students made a strong case for the capacity of ICT to facilitate the development of these competencies.

Third, and more generally speaking, we grouped the main challenges that the education actors at the Eastern Townships School Board faced, and which they could overcome in the coming months:

1. universal access to good quality equipment;
2. the time required to properly prepare lessons and activities that take full advantage of ICT in class;
3. class management;
4. students' information literacy.

The greatest challenge concerned the equipment itself, underscored by 52.9% of the teachers and 71.2% of the students. Moreover, as the results show, the other challenges paled by comparison. It is also understandable that the teachers and students, with their extensive experience in using ICT in education, would appreciate having better equipment to work with.

Among the other challenges were lack of time, which will probably always remain a problem in teaching, a notoriously time-consuming profession. Classroom management was also an unavoidable downside of teaching. Nevertheless, through greater use of ICT, these challenges can be handled better. Moreover, teachers can take some reassurance from the fact that the students at the Eastern Townships School Board were also aware of these challenges. This would appear to be a first step in the search for a solution. Students' information literacy was the fourth challenge that teachers faced. Some students were unable to judge the validity of the information they found, particularly in today's society, with its deluge of Internet information. However, this fourth challenge also had a flip side. Students at the Eastern Townships School Board were probably far better at using technologies than any other students in Quebec, thanks to their many years of using technologies in class.

Fourth, the data gathered in this study revealed 10 main benefits to using technologies in class for teaching and learning :

1. Students' motivation
2. Access to information and educational resources, for both students and teachers
3. Students' writing skills
4. Students' effective work methods
5. Students' feelings of competence
6. Individualized learning

7. Students' quality of work
8. Easier communication, cooperation and teamwork, for both teachers and students
9. Better preparation of youth for the future, and for their own future
10. Students' creativity.

We find motivation at the head of the list of benefits of using technologies in class. Of the 2,712 surveyed students, 94.3% said that they liked using computers in class. We may note that 89.3% stated that using technologies in class helped them learn. The perceptions of these benefits by the almost 3,000 students who participated in the study suggest that the use of technologies in the classroom for teaching and learning can play a major role in academic success.

Another particularly interesting result of this study was the attitude of the Eastern Townships School Board teachers towards technologies. It is frequently argued in the literature on ICT integration in education that ICT are motivating for students, but that teachers are less enthusiastic (e.g. [32]), because they have to change their teaching practices in order to incorporate them. As indicated by [32], it is particularly unusual to find so few teachers expressing a negative attitude about technologies (less than 4% of the surveyed teachers).

In light of the results of this second study, we may hypothesize that the "one laptop per child" program implemented at the Eastern Townships School Board contributed to some extent to the students' achievement rate. Although it is almost impossible to relate the teachers' ICT use with school success—which was not our objective in this research project—there is no doubt that the results clearly highlight that the pedagogical use of technologies, by both teachers and students, improved the teaching context (enhanced writing skills, creativity, communication, cooperation, work methods, critical judgment, etc.), which could have played a significant role in the students' achievement.

In other words, the teaching context put in place at the Eastern Townships School Board may have contributed to the outstanding decrease in the student dropout rate (by almost 50%) over the succeeding decade. Above all, this remarkable progress, which we may attribute in part to a well-planned use of technologies for teaching and learning in the classroom, would not have been possible without the complete commitment and outstanding skills of the teachers, school principals, and other education stakeholders at the Eastern Townships School Board. This also means, implicitly, that the official statistics

on student dropout rates at this school board are in line with the results of this second inquiry, which highlighted, among other things, the central role that technologies play in developing students' writing skills and other key competencies central to students' achievement rates.

Many educators and sociologists contend that the fight against school dropout must be taken beyond the school walls, and that it is a matter of concern not only for those who work in the education field, but also for the students, their parents, the entire community, and the governments. Even though the Eastern Townships School Board has succeeded over ten years in almost halving their dropout rate, elsewhere in Quebec, over 18,200 adolescents quit school each year, steadily increasing the pool of undereducated citizens [46]. Not only do they not have a high school diploma, their future will be more challenging. If the Government of Quebec wants to intensify the battle against dropout and improve the odds of succeeding for its youth, thereby ensuring Quebec's future growth, it would do well to take notice of this commendable initiative by the Eastern Townships School Board to implement pedagogical and technological change. It should find ways to introduce technologies into the classroom under a widespread, carefully considered educational program. However, not just any technology will do. Our investigation revealed a key element for academic success: each student and teacher, in line with their school context and pedagogical needs, seem to benefit more from using their own laptop than any other technology.

## 6. References

- [1] Anis, J. (1998). *Texte et ordinateur – L'écriture réinventée?* Brussels, Belgium: De Boeck.
- [2] Annan, K. (2005). *La société de l'information est indispensable sans liberté, sans transparence, sans le droit de chercher, de recevoir et de répandre les informations et les idées, prévient Kofi Annan.* New York, NY: Nations Unies, Département de l'information, Service des informations et des accréditations.
- [3] Atkins, D. E., et al. (2010). *Transforming american education: Learning powered by technology. Draft of the National Educational Technology Plan 2010.* Washington, DC: Office of Educational Technology, U.S. Department of Education.



- [4] Balanskat, A., Blamire, R., & Kefala, S. (2006). *The ICT impact report. A review of studies of ICT impact on schools in Europe*. Brussels, Belgium: European Schoolnet.
- [5] Bandura, A. (2003). *Auto-efficacité: le sentiment d'efficacité personnelle*. Brussels, Belgium: De Boeck Université.
- [6] Bebell, D., & Kay, R. (2010). One to one computing: A summary of the quantitative results from the Berkshire Wireless Learning Initiative. *Journal of Technology, Learning, and Assessment*, 9(2). Retrieved from <http://ejournals.bc.edu/ojs/index.php/jtla/index>
- [7] British Educational Communications and Technology Agency. (2006). *The BECTA review 2006. Evidence on the progress of ICT in Education*. Coventry, UK: Becta ICT Research.
- [8] British Educational Communications and Technology Agency. (2005a). *Tablet PCs in schools. Case study report*. Coventry, UK: Becta. Retrieved from <http://dera.ioe.ac.uk/1462/>
- [9] British Educational Communications and Technology Agency. (2005b). *Tablet PCs in schools. A review of literature and selected products*. Coventry, UK: Becta. Retrieved from <http://dera.ioe.ac.uk/1461/>
- [10] Brulland, I., & Moulin, C. (2006). Y faux camp m'aimefer attends scions. *Cahiers pédagogiques*, 440, 29-30.
- [11] CEFRIO. (2012). Les médiassociauxancrés dans les habitudes des Québécois. *NETendances 2012*, 3(1). Retrieved from <http://www.cefrio.qc.ca>
- [12] CEFRIO. (2011). Mobilité: le téléphone intelligent en croissance au Québec. *NETendances 2011*, 2(3). Retrieved from <http://www.cefrio.qc.ca>
- [13] Conseilcanadiensurl'apprentissage. (2011). *Quelest le futur de l'apprentissage au Canada?* Ottawa, ON: CCA. Retrieved from <http://www.ccl-cca.ca/>
- [14] Cordier-Gauthier, C., & Dion, C. (2003). La correction et la révision de l'écrit en français langue seconde: médiationhumaine, médiationinformatique. *Alsic*, 6(1). Retrieved from <http://alsic.revues.org/2149>
- [15] Deci, E. L., & Ryan, R. M. (2000). Self-determination theory and the facilitation of intrinsic motivation, social development, and well-being. *American Psychologist*, 55(1), 68-78.
- [16] Dohn, N. B. (2009). Web 2.0: Inherent tensions and evident challenges for education. *International Journal of Computer-Supported Collaborative Learning*, 4(3), 343-363.
- [17] Fielding, N. G. (2012). Triangulation and mixed methods designs: Data integration with new research technologies. *Journal of Mixed Methods Research*, 6(2), 124-136.
- [18] Fleischer, H. (2012). What is our current understanding of one-to-one computer projects: A systematic narrative research review. *Educational Research Review*, 7(2), 107-122.
- [19] Freiman, V., Beauchamp, J., Blain, S., Lirette-Pitre, N. et Fournier, H. (2010). Does one-to-one access to laptops improve learning: Lessons from New Brunswick's individual laptop school initiative. *Procedia - Social and Behavioral Sciences*, 2(2), 5686-5692.
- [20] Gilmore, J. (2010). Tendances du taux de décrochageet des résultatssur le marché du travail des jeunesdécrocheurs. *Questions d'éducation : le point surl'éducation, l'apprentissage et la formation au Canada*, 7(4). Retrieved from <http://www.statcan.gc.ca/pub/81-004-x/2010004/article/11339-fra.htm>
- [21] Goldberg, A., Russell, M., & Cook, A. (2003). The effect of computers on student writing: A meta-analysis of studies from 1992 to 2002. *Journal of Technology, Learning, and Assessment*, 2(1). Retrieved from <http://ejournals.bc.edu/ojs/index.php/jtla/article/view/1661/>
- [22] Grimes, D., & Warschauer, M. (2008). Learning with laptops: A multi-method case study. *Journal of Educational Computing Research*, 38, 305-332.
- [23] Gulek, J. C., & Demirtas, H. (2005). Learning with technology: The impact of laptop use on student achievement. *Journal of Technology, Learning, and*

*Assessment*, 3(2). Retrieved from <http://ejournals.bc.edu/ojs/index.php/jtla/article/view/1655/>

[24] Holcomb, L. B. (2009). Results & lessons learned from 1:1 laptop initiatives: A collective review. *TechTrends*, 53(6), 49–55.

[25] Huberman, A. M., & Miles, M. B. (1991). *Analyse des données qualitatives. Recueil de nouvelles méthodes*. Brussels, Belgium: De Boeck Université.

[26] Huberman, A. M., & Miles, M. B. (1994). Data management and analysis methods. In N. K. Denzin et Y. S. Lincoln (Eds.), *Handbook of qualitative research* (p. 428-444). Thousand Oaks, CA: Sage.

[27] Hutchison, A., & Reinking, D. (2011). Teachers' perceptions of integrating information and communication technologies into literacy instruction: A national survey in the United States. *Reading Research Quarterly*, 46(4), 312-333.

[28] Karsenti, T., & Collin, S. (2011). *Avantages et défis inhérents à l'usage des ordinateurs au primaire et au secondaire : Enquête auprès de la Commission scolaire Eastern Townships. Synthèse des principaux résultats*. Montréal, QC: CRIFPE.

[29] Karsenti, T., Komis, V., Depover, C., & Collin, S. (2011). Les TIC comme outils de recherche en sciences de l'éducation. In T. Karsenti, T. and L. Savoie-Zajc (Eds.), *La recherche en éducation : étapes et approches* (3<sup>rd</sup> éd., pp. 277-301). Ville Saint-Laurent, QC: ERPI.

[30] Ladbrook, J., & Probert, E. (2011). Information skills and critical literacy: Where are our digikids at with online searching and are their teachers helping? *Australasian Journal of Educational Technology*, 27(1), 105-121.

[31] L'Écuyer, R. (1990). *Méthodologie de l'analyse développementale de contenu. Méthode GPS et concept de soi*. Québec, QC: Presses de l'Université du Québec.

[32] Livingstone, S. (2012). Critical reflections on the benefits of ICT in education. *Oxford Review of Education*, 38(1), 9-24.

[33] Ministère de l'Éducation, du Loisir et du Sport. (2010). *Taux de décrochage annuel*. Québec,

QC :Gouvernement du Québec. Retrieved from <http://www.mels.gouv.qc.ca/sections/publications/index.asp?page=fiche&id=1586>

[34] Ministère de l'éducation du Québec. (2001). *Programme de formation de l'école québécoise*. Québec, QC: Gouvernement du Québec.

[35] Morrison, G., Ross, S. M., & Lowther, D. L. (2009). Technology as a change agent in the classroom. In L. Moller, J. B. Huett & D. M. Harvey (Eds.), *Learning and instructional technologies for the 21st century* (pp. 151-173). New York, NY: Springer.

[36] O'Reilly, T. (2005). *What is Web 2.0 : Design patterns and business models for the next generation of software*. Retrieved from <http://oreilly.com/web2/archive/what-is-web-20.html>

[37] Organisation for Economic Co-operation and Development. (2012). *Connected minds: Technology and today's learners*. Paris, France: OECD Publishing.

[38] Organisation for Economic Co-operation and Development. (2008). *New millennium learners: Initial findings on the effect of digital technologies on school-age learners*. Paris, France: OCDE Publishing.

[39] Penuel, W. R. (2006). Implementation and effects of one-to-one computing initiatives: A research synthesis. *Journal of Research on Technology in Education*, 38(3), 329-348.

[40] Purcell, K., Rainie, L., Heaps, A., Buchanan, J., Friedrich, L., ... & Zickuhr, K. (2012). *How teens do research in the digital world*. Washington, DC: Pew Research Center's Internet & American Life Project. Retrieved from <http://pewinternet.org/Reports/2012/Student-Research>

[41] Ramboll Management. (2006). *E-learning Nordic 2006. Impact of ICT on education*. Copenhagen, Denmark: Ramboll Management.

[42] Redecker, C. (2009). *Review of learning 2.0 practices: Study on the impact of Web 2.0 innovations on education and training in Europe*. Seville, Spain: Institute for Prospective Technological Studies.

[43] Rogers, L. A., & Graham, S. (2008). A meta-analysis of single subject design writing intervention research. *Journal of Educational Psychology*, 100(4), 879-906.

[44] Siemens, G., & Tittenberger, P. (2009). *Handbook of emerging technologies for learning*. Winnipeg, MB: University of Manitoba. Retrieved from <http://elearnspace.org/Articles/HETL.pdf>

[45] Spektor-Levy, O., Menashe, K., Doron, E., & Raviv, D. (2010). Learning with personal laptops in school: benefits & gains, obstacles & constraints. In Y. Eshet-Alkalai, A. Caspi, S. Eden, N. Geri & Y. Yair (Eds.), *Proceedings of the Chais conference on instructional technologies research 2010: Learning in the technological era* (pp. 81-86). Raanana: The Open University of Israel.

[46] Statistique Canada. (2011). *Enquête canadienne sur l'utilisation d'Internet*. Ottawa, ON : Statistique Canada. Retrieved from <http://www.statcan.gc.ca/daily-quotidien/110525/dq110525b-fra.htm>

[47] Suhr, K. A., Hernandez, D. A., Grimes, D., & Warschauer, M. (2010). Laptops and fourth-grade literacy: Assisting the jump over the fourth-grade slump. *Journal of Technology, Learning, and Assessment*, 9(5). Retrieved from <http://ejournals.bc.edu/ojs/index.php/jtla/index>

[48] UNESCO. (2005). *Vers les sociétés du savoir*. Paris, France: Éditions UNESCO.

[49] Walraven, A., Brand-Gruwel, S., & Boshuizen, H. P. A. (2008). Information-problem solving: A review of problems students encounter and instructional solutions. *Computers in Human Behavior*, 24(3), 623-648.

# The Mathematics Worksheet as Pedagogical Genre: A Hegemonic, Homogenizing Force Affecting Power and Identity Relationships in the Secondary Classroom

Ozlem DENIZ  
University of British Columbia  
Vancouver, Canada  
[ozlem.deniz@ymail.com](mailto:ozlem.deniz@ymail.com)

## Abstract

*While mathematics worksheets play an important role shaping mathematics classroom culture and interactions among the members of the classroom community, there have been few attempts to describe and understand these constitutes and their effects on the sociology of the classroom. This research explores whether the worksheet as a pedagogic genre has the effect of a hegemonic, homogenizing force in the high school mathematics classroom. Drawing from Gerofsky's (forthcoming) ten-step analytic approach, I analyze data from two countries, Turkey and Canada, from my positioning as a graduate researcher in mathematics education at a Canadian university with teaching experience in both countries, cultures and languages. Teacher interviews, focus group discussions, and textual and contextual analysis of these generic constructions may lead to a better understanding of mathematics teaching and learning practice by revealing the tacit assumptions of the field. The findings may also be applied to teacher education as well.*

## Introduction

From kindergarten to the end of secondary school, worksheets are a very common and dominant teaching/learning tool in mathematics education with profound effects on pedagogy, not only in Turkey, but all around the world and in many different cultures. The existence of worksheets in many different education systems in a very similar way is an indicator of how mathematics education is perceived and implemented. The lack of studies in this area is astonishing. Part of a broader research project, this paper aims a better understanding of mathematical worksheet as genre and its impact on power relationships in the classroom.

In this paper I draw on the genre theory, particularly from rhetorical genre perspective where genre is seen as constellations of typified, regulated, recurrent strategies [29, 38]. Gerofsky (2011)

says "...although a genre maybe a category, it is a generative, self-referencing, dialogical, resonant one, constantly in a state of change and development" (p14). According to rhetorical genre studies, these recurrent strategies are generated by the interaction between an individual's socialization and an organization. Since a genre is embedded in situation and culture, genre analysis of a given text would provide insights about "how texts mediate situated symbolic actions" (Bawarshi, 2010, p.54). Thus, through studying and understanding generic forms it becomes possible to navigate the intensions and motivation or power relations and ideologies hidden in the text and in the context as well [38]. Genre analysis also reveals the function of a text, its effects, and how other people may perceive it [10]. That view goes along with the socio-constructive approach and emphasise the importance of the dialectic relationship in between individual and society and the prominence of the wider social, political and cultural contexts in which text is both context-constrained and context-creating (Bhatia, 2012).

Gerofsky (1996, 1999, 2011) discusses pedagogical genre analysis as a potentially viable way to understand "culturally-recognizable forms" in mathematics education (forthcoming, p.1). In her later study, Gerofsky asserts that questioning the pedagogical forms or discourse in mathematics education through the lenses of genre theory may help revealing "the tacit assumption of [the] field, including some that are unconsciously inherited from outside of the field itself". This approach to worksheets as genre involves "[asking] ontological questions about the existence and nature of [these] particular generic forms, including their relationship to other cultural genres" and explores the question of "what are worksheets?" from many different disciplinary perspectives (forthcoming, p.1).

## Mathematics worksheets in the literature

If the text books are the most common texts used in mathematics education, worksheets should be the second in the list. Although there is a lot of research done on text books [e.g. 2, 11, 12, 21, 22, 38], there is very little research done focuses on worksheets [e.g. 32, 34]. However, the worksheets are mentioned in many recent studies and are mostly criticized. For example, Suzanne M. Wilson (2002) identifies worksheets as repetitive a skill-drill tool which promotes “solitary work” rather than “community activity”. She addresses the dominance of worksheets in the classrooms as a result of oppressive progressivism and she criticizes the entire education system which discourages critical, multilayered and meaningful thinking.

A study from the sixties, on the other hand, has a totally different perspective. In her article, Potamkin (1963) mentions her experience with ditto worksheets and says “instead of being circumscribed and hemmed in by the indoctrination of prescribed doses of knowledge, the pupils are given a direction and released to follow it [through the use of worksheets]”(p.163). Potamkin says that the idea of creating worksheets inspired by a necessity to provide work about a particular topic which is not covered by the text-book however then worksheets become a center piece of a new teaching approach which she calls as individualized learning. In her implementation of worksheets (which is mainly based on creating a worksheet center resource with different level of worksheets regarding every one of the topics for students free use) students became involved in their learning more, they developed self-esteem, class atmosphere evolved to a more co-operative and collaborative environment, students engaged in their learning process and learning itself more in a positive way.

The way Potamkin uses these worksheets gives students autonomy in their learning and positively affects the learning. I believe this practice is far beyond the practices had been implemented during that period of time and actually presents itself as a renovation. Nevertheless, Potamkin’s articulation of her practice raises many questions regarding limited student learning activities and positioning the students as the receiver of the information but not the creator.

Mousley’s study asserts that the common use of worksheets may constitute a predominant influence in the classroom and hinders students’ learning in the

sense that students are forced to learn in one way and are treated as cohorts rather than individuals with different abilities, interests and needs (Mousley, 2012). This might lead the teacher or the text of worksheet becoming the only source for knowledge (i.e., power) and leaving little room for students to contribute to the creation of knowledge. Moreover, most mathematics worksheets emphasize the procedural and calculational aspects of mathematics but not conjecturing, relating, testing or describing nature of mathematics. That brings barriers to teachers’ and their students’ imagination and creation and closes a door towards exploration of knowledge by implementing a fixed curriculum. Mousley’s study indicates the importance of investigating worksheets in terms of their textual and contextual features (i.e., cultural, social, political aspects) in secondary school classrooms to gain a deeper understanding of the nature of worksheets that depicts my aim in my study.

## Genre studies in the field of mathematics education

The application of the genre theory to mathematics education is a rather new field with a great potential to be used as a grounding theory for further investigations of invisible generic forms of school mathematics. These investigations not only shed light on our understanding of the importance of generic forms, discourse or written text in the learning and teaching mathematics but also identify their role in shaping mathematics classroom culture and power relations among the members of this community.

Wallace and Ellerton’s (2004) study, also draws from socio-linguistic perspective and discusses the notion of genre and register in the language of mathematics. Authors define language genres as “forms in which discourse participants communicate within social contexts” (p.1) and associate genre to culture and “communicative events” (p.6). According to this study the language genre of school mathematics behaves “a sub-genre of the whole of mathematics”, is “multi-dimensional” and “is constituted by many sub-genres” (p.10). Authors draws our attention to “the complexities of the conceptual bases of language genre, discourse and register” in the context of mathematics teaching, learning, and address genre studies as an important way towards understanding the role of language in school mathematics classrooms.

Drawing from Martin’s (1985) *Factual Writing*

study, Marks and Mousley (1990) discuss the echo of the “process writing movement” in mathematics education and criticize this perspective as it emphasises the use of one particular genre, recount genre, in primary and secondary school mathematics classrooms (p. 117). Yet, the authors argue that “to be mathematically literate, students need to be able to control a number of different context-appropriate genres of mathematics” (p.134). They identify the five factual genres “accessible to students” in mathematics as procedural, description, report, explanatory and expository genres (p.119).

The findings of this study indicate that in the mathematics classrooms “genre expectations are both limited and limiting” (p.117); however, mathematics teaching and learning can be enhanced through raising teachers’ awareness to a broad range of mathematical genres available. This would lead students “to imagine, to report, explain, judge and teach” and involve in “expressive activities” (p.127) through the use of “labels, charts, pictures, posters, mobiles, books, models, exhibitions” (p.133). Nevertheless, Gerofsky (forthcoming) critiques this approach as it conceptualizes genres from a taxonomic perspective that is limited to analysing genres through their functionality, while admitting the potential it has to understand “the communicative intentions” in school classrooms (p.2). In terms of my investigation of worksheets, these classifications presents itself as potentially viable tools to analyse and understand different language genres employed in the worksheets and allow me to elaborate on their functionalities.

By following the discussion about process writing trend where students are encouraged carry out a sequence of stages, Solomon and O’Neill (1998) investigate the narrative approach in mathematics texts. In their critique, the authors say that the process approach puts forward recount or narrative in the creation of mathematics writing; however, a genre approach embracing “authorship and creativity” (p.210) could offer some solutions for “mathematical under-achievement” (p.219).

Drawing from linguistic approach Candia Morgan (1996) suggests a method to analyse mathematical texts through the analysis of three language metafunctions: “Ideational, interpersonal and textual” (Halliday, 1973 as in Bawarshi 2010, p.30): Bawarshi asserts that “[i]deational refers to the linguistics representation of action (answer the questions of who is doing what, to whom, when and where?” (p.31). Morgan suggests asking “What is mathematics (as it appears in the text being analysed)?” to

consider ideational aspect in a mathematical text (1996, p.3). In her study, Herbel-Eisenmann (2007) examines ideational function of a textbook through discussing “a) who is involved in doing what kinds of processes; and b) the depiction or suppression of agency” (p.351). Likewise, Morgan (1996) discusses “nominalization” which excludes the participants who are actually doing the activity by internalizing the process as object (e.g. use of rotation versus rotation) (p. 1).

The second metafunction-interpersonal defines the interaction between participants of the discourse (Bawarshi, 2010, p.31) and requires examining how the readers are positioned in relationship to mathematics ). Herbel-Eisenmann’s [30] study traces the use of “imperatives, pronouns and modality” to understand the interpersonal function (2007, p.349). As Bawarshi says “[t]extual describes the flow of information within and between texts, including how texts are organized, what is made explicit and what is assumed as background knowledge, how the known and the new are related...” (2010, p.31). Morgan examines this function through asking the message conveyed through the mathematical text, and considering “the ways in which reasoning is expresses” (p.7). Herbel-Eisenmann (2007) considers textual function by analyzing “the modes of reasoning and the features of the text that preserve continuity” (p.351).

## Methodology

This study was conducted between June 2012 and May 2013 at the University of British Columbia with an approved ethics protocol. Pseudonyms are used in reporting for confidentiality.

## Participants

I conducted focus groups and interviews and analysed text using genre analysis to investigate the place of worksheet in secondary school level mathematics education. The subjects were eight international graduate student-teachers in the Curriculum and Pedagogy Development of UBC, a retired teacher and the researcher herself. Three male and seven female teachers with ages in between 25 to 82 participated the study. These ten teachers brought their teaching/learning experience which has taken place in nine different countries and four different continents. The wide range of different experiences and insights enriched research data and deepened focus group discussions and pre and post interviews.



### Methods followed and data collection

Grounding on genre theory, I employed Gerofsky's (forthcoming) ten steps pedagogical genre analysis method in my research. Overall my methodological approach included quantitative and qualitative analysis of my data as summarized in the Table 1 below:

My research data sources include samples of worksheets, pre and post interviews with teachers (participants) through e-mail, audiotaped semi-structured focus group discussion, e-mail correspondence with teachers, researcher's journal, field notes and observations and also samples of culturally recognizable forms of worksheets such as movie clips, cartoons, jokes or blogs.

### Qualitative data collection

Focus group data are analysed as in Krueger & Casey's (2009) focus group analysis procedure suggested where the researcher "needs to consider many different aspects of the focus group and its participants' responses, including words the participants use in the discussion, context, internal consistency of the participants' views, frequency of comments, degree of agreement on a topic, intensity of feeling toward a topic, specificity of responses, and "big ideas" that emerge from the discussion" (p.16) within the consideration of genre analysis. My focus groups were semi-structured in their nature in the sense that I wanted to guide the discussion around worksheets with targeted questions centred on my research questions, while encouraging them to share their ideas from other experiences as they relate to worksheets in general as well. I purposefully chose 32 different worksheets that I collected from different resources in 3 different languages, containing drill-practice questions, critical thinking questions and questions with different representations to probe their thoughts on these features.

Interviews, on the other hand, were structured: Pre-interviews helped me to gather background information about participants and also get them start to think about worksheets and their own practice of using worksheets. Through post-interviews I attempted to clarify the points raised in the focus group discussions with follow-up questions. Pre and post interviews with participants were analysed through constant comparative method within the consideration of genre analysis [28].

**Table 1. Summary of the methodology followed**

<b>GENRE ANALYSIS OF WORKSHEETS (Gerofsky, forthcoming)</b>
1) Evidence of existence: Looking for the clues embedded in the cultural form like cartoons, jokes, books, blogs etc.
2) Collecting exemplars: <i>central to, peripheral to and contrasting with the genre</i>
3) Generative processes: Considering new forms and processes where these new forms arise.
4) Resonances: Investigating analogies, similarities with other genre forms.
5) Archaeology of genre: Examining the origin of the genre.
6) Finding patterns of features which are common to that particular form. In my study I focused on linguistic aspects through: Functional category (Morgan, 1996 as in Herbel-Eisenmann, 2007) and critical discourse analysis (as in Schryer, 2000)
7) Typical time/space images evoked (characterization of the genre's chronotope) Chronotopic analysis of agency (as in Schryer, 2000).
8) Use qualitative empirical study to test hypotheses about the nature of the genre and its sociocultural functions: Focus group (Krueger & Casey, 2009) Personal interviews (Mesa and Griffiths, 2012).
9) Pushing the boundaries: thinking the genre form otherwise: Genre Bending (Cawelti, 2003; Berliner, 2001).
10) Revisiting pedagogy of the genre: Looking for new possibilities for pedagogy.

### Quantitative data collection - collection of worksheets

Worksheets were compiled from different sources such as research participants' and researcher's own repertoire, web-sites, workbooks and library archives. In this examination I studied 329 questions in 25 mathematics worksheets that were provided by seven research participants who have up to 25 years of teaching experience in seven different countries and different grade levels. Specifically asked the participants to bring sample worksheets representing different categories per Gerofsky's (forthcoming) method suggested: the ones that they commonly use in their practice (i.e., central to the genre), and the ones that they think they are different in some aspects (i.e., in the peripheral or contrasting with the genre).

## Limitations

One consideration was that the high school students' perspective was missing in the study. This was attempted to be addressed by asking the participants about their students' perceptions of the worksheets to incorporate students' perspectives indirectly. The worksheets collected from the participants were from different grade levels and different topics. It would be interesting to run the same analysis focusing on a given grade level and/or a topic to gain further insights. In the process of text analysis I could not use word processor because some worksheets were in different formats. Therefore, I counted words by myself that might lead some minor errors. Other limitation was some worksheets' being in Chinese. One of the research participants, Gina, helped me in the translation of these worksheets. I came up with the following suggestions to push the boundaries of using worksheets, and to bring a fresh look at their form, context, focus or functions:

## Findings

*Following I report from sixth step of Gerofsky's genre analysis: Finding Patterns of Features.*

In each of the steps of my worksheet analysis I gained a great deal of insights and had a chance to view the whole picture from different perspectives. For example, taking a journey to history of worksheets helped me understand the "kairos" the right moment that mathematics worksheets raised and led me to think about the past, the present and the future of mathematics education where worksheets have been in use. In another step, examining resonances allowed me to realize that there are not only the formalistic but also intentional similarities and differences among different genres within the schooling systems.

In this sixth step, I aimed at developing a better understanding of patterns of cultural and linguistic features embedded in the worksheet genre. These clusters of features characterize mathematics worksheet genre that has the power to format mathematics teachers' and students' activities, dispositions, interactions and thus, format mathematics classroom culture.

In this phase of genre analysis, I particularly focused on the language used in the worksheets. I examined word, sentence, question selections and identified linguistic forms to interpret their functions [. These language constructions within the genre of

the text, as Herbel-Eisenmann and Wagner (2005) assert, create roles for the learner and determine the position of the learner in relation to the other members of classroom community and in relation to the mathematics activities. This is how Bakhtin considered a genre, where discourse is got shaped, addresses its audience in a particular way. In this sense, within the scope of my research critical discourse analysis and examination of linguistic structures appeared in the mathematics worksheets revealed insights in regards to how the counterparts of the discourse (students and teacher) are posited in relation to each other and also in relation to mathematics.

In order to study this formatting power of language encapsulated in worksheet genre, I focused on the functional aspects of linguistics forms as "Ideational, interpersonal and textual" (Halliday, 1973 as in Bawarshi, 2010, p.30). In this examination I mainly followed the method offered by Morgan (1996) and employed by Herbel-Eisenmann (2007) in their examination of mathematics textbook.

Interpersonal function, says Morgan (1996), "expresses social and personal relations between author and others" (p.3). To understand interpersonal function which centres social relations, power and authority structures in the text I traced the use of imperatives, pronouns, modality, and question forms throughout the research data. According to Morgan (1996), the examination of use of personal pronouns not only help us to understand "author's personal involvement with the activity portrayed in the text" but also indicates how the reader is expected to be involved in the activity as well (p.5). Through analysis of use of imperatives and modality, the relations constructed among author (teacher), readers (students) and subject matter of the text (mathematics) can be perceived because these forms indicate how the reader and the author are addressed "in the responsibility for the construction of the mathematics argument" (p.6).

Alongside of the inquiry of interpersonal aspects, the ideational and textual functions are considered and interspersed throughout the section. I paid attention to ideational function through investigating the portrayal of agency in the process of mathematisation. Analysis of ideational function helped me to realize how the nature of mathematics presented in the worksheets through the examination of activities and processes the readers supposed to involve in. Lastly, I studied textual function in terms of how worksheets are organized as a whole to deliver what kind of "message", what is assumed



regarding doing mathematics in the whole text of worksheets and how mathematics reasoning is “expressed” mathematics raised (Morgan, 1996, p.7).

Following is the findings of examination of interpersonal, ideational and textual functions of the language fulfilled in my entire research data by the particular “choices” of “structures and content” (Morgan, 1996, p.3). Each participant (except Mohna and Malka) provided three to four different worksheets from six to eleven grade levels. Participants provided with one or two regular worksheets that they use in their daily teaching often (samples central to the worksheet genre) and one or two different type of worksheets (the ones peripheral to or contrasting with the worksheet genre).

**Table 2. Frequency of pronouns, imperatives, modality and question forms**

Use of pronoun	Use of imperatives	Use of modality	Use of question form
37 times	140 times	23 times	84 times
You(19) We(2) Third person pronoun(18)	Inclusive: (17) Exclusive: (123)	Can(1) Would(4) Must(2) Could(2) Will(1) May(3)	What(62); How many(2), Why(6), Which(3), Can you(4), Other forms(7)

### Imperatives

The most frequently occurring linguistic form in my full data set was imperatives. I observed 140 imperative embedded forms in 329 questions. By taking into consideration of Rotman’s (1988) study I examined inclusive and exclusive imperatives separately. Rotman claimed “inclusive imperatives” such as explain, consider, compare, predict, prove, etc. invite the students to behave as a part of the mathematical community; however, “exclusive imperatives” require doing more straight forward mathematics and tells the students “what to do and how to the” with an “authoritative voice” like write, draw, find and calculate (as in Herbel-Eisenmann,

2007, p.350, 354). As such, analysis of imperatives led me to understand how the authors (teachers) position readers (students) in the process of construction of mathematics. I observed 17 inclusive to 123 exclusive imperatives in my data, that is, the use of exclusive imperatives were seven times more than inclusive imperatives use. Apparently, in these worksheets students were not addressed as members of the mathematical community who construct the knowledge and create but receivers who are the “scribbler” not “thinker” (p.350).

The most common imperatives were “find”, “calculate”, “write”, “express”, “determine” and solve. Interestingly, “find” and “calculate” were not accompanied by any other words or sentences but used as solo just before operational questions. As Bakhtin says in every utterance, the producers (speakers-authors) make choices from the available resources and structures which are get shaped by the cultural and social motives. According to Schyer (2000) these choices are not arbitrary but are driven by the writer’s position to the subject matter and to the audience as well. As such, these specific use of “find”, “calculate” and other mentioned imperatives across worksheets data associate to “progressive education” where the students’ role is prescribed as doing and being accurate. The voice of authors appeared authoritative and there was very limited space created for negotiation. From these perspectives, it becomes important to promote different kinds of activities by the use of different inclusive imperatives and getting students interact with the text in an expressive way.

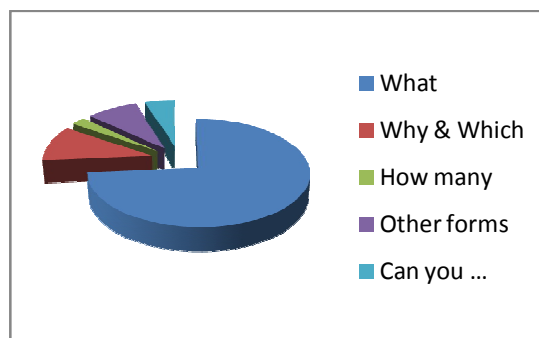
**Table 3. Inclusive and exclusive imperatives in the research worksheet data**

Inclusive Imperatives TOTAL: 17		Exclusive Imperatives TOTAL: 121	
Most Common	Rare	Most Common	Rare
“Show” (3) “Develop a strategy” (3) “Explain” (2) “Describe” (2)	“Perform” (1) “Decipher” (1) “Make a conjecture” (1); “Investigate” (1) “Model” (1) “Create” (1) “Apply” (1)	“Find” (16) “Calculate” (14) “Write down” (9) “Express” (8) “Determine” (8) “Solve” (7) “Graph” (6) “Answer” (6) “Simplify” (5) “Fill” (6) “Reduce” (5) “Get the answer” (4) “Record” (4)	“Draw” (3) “Divide” (3) “(Re-)Evaluate” (3) “Use” (2) “Give answer” (1) “Read” (2) “Look” (1) “Tell” (1) “Complete” (2) “Classify” (2); “Sketch” (2); “Name” (1) “Order” (1) “Check” (1)

**Question forms**

I also analyzed the appearance of question forms. I treated question forms like exclusive and inclusive imperatives in that they either invite students to become members of mathematical community or exclude them from the process of creating mathematical knowledge. For example, the question “what” or “how many” could be considered as an exclusive form because it usually requires a pretty

straight forward answer and reflects the author’s authoritative voice. Whereas more inclusive forms such as “which” or “why” equalize the power relation in between the author/teacher and the students and encourage comparing, reasoning, explaining, and relating activities. Across worksheets I saw the dominance of “what” (62 times) questions that emphasize carrying out a particular activity and doing the operations. Nevertheless, “which” or “why” (17 times) involve the students with the process where students are led to use different representations, to make comments, and to come up with new strategies. The other view from Rowland (1995) helped me to understand the importance of using different question forms. For instance, “what” questions require a certainty however as Rowland argues “uncertainty is a productive state, and a necessary precondition for learning” (p.328). If students feel comfortable being in this state then they will be able to estimate, predict and generalize during mathematical processes. Therefore, emphasis on exclusive imperative or question forms might have hinder internalization of my students’ learning which I need to take into consideration in my practice.



**Figure 1 Frequency of question forms**

**Pronouns**

The use of first person pronouns refers to the author’s “personal involvement” to the text (Morgan, 1996, p.5). The plural pronoun (i.e., we) may indicate an inclusive voice referring the author and the reader or may indicate the mathematical community making a claim [33, 21]. Therefore, use of “we” could be inclusive and invite reader-student to be a part of the mathematics community and contribute or could be exclusive and animate an authoritative voice of expert mathematicians. The use of singular pronoun (i.e., I) demonstrates a real human agency doing the

activity; the use of “you” on the other hand addresses the reader directly and involves with the process. However, the involvement of “you” in the consideration of nominalization (the language structure that conceal human agency like the use of rotation rather than use of rotate) is very important because the use of second personal pronoun could be in two ways: i) you+verb and ii) an inanimate object+an animate verb+ you (as direct object). The second use may mask the involvement of human who is actually doing the activity like “the chart tells you..” (you are the one who is interpreting the chart which is not literally “telling” you). As Morgan (1996) says the absence of first or second pronouns shadow the human involvement with mathematics and distances both mathematics and the author from the reader.

In these twenty two different worksheets I observed many limited pronoun usages. Overall, among 35 pronouns, only 2 of them were first person plural pronouns (we), 19 of them were second person pronouns, and 18 of them were third person pronouns. There were no first person singular pronoun usages at all. All the third person pronouns were used in a specific word problem worksheet where, interestingly, there were no question including first or second person pronouns.

This very narrow use of pronouns demonstrated the lack of agency in the worksheets. Students are only in few worksheets addressed as active actors doing, sharing, generating mathematics. In most of these worksheets human actors were removed from the scenes and mathematics depicted as a formation aside from humans. According to many scholars (e.g. Morgan, 1996; O’Hallaran, 2004), this picture would reinforce the students’ role as watching, doing and following but not creating, reasoning or interpreting mathematics and students are left without any space to raise their own voice in these detached mathematical activities.

### Modality

Modality is another important aspect of text that reveals how human agency is constructed in the text. The modality indicates the certainties or probabilities that the producer of the text established throughout the text [23]. Modality can be examined through the use of modal auxiliary verbs such as must, will, could, or might [30]. According to Herbel-Eisenmann and Wagner (2005) “would, can and will” demonstrate “stronger conviction” whereas “could and should” express “weaker conviction”. The

weaker modality show less certainty. As Rowland (1995) argues being in the state of uncertainty helps with learning because this state opens space for students’ awareness, discussion, interpretation and contribution. After then students can estimate, predict and generalize in mathematical processes. Rowland also drag our attention to hedged forms which are words or phrases implying uncertainty, such as might, maybe, probably. These forms comply with the modality and determine the tone of text in terms of its strong certainty. Below is the chart showing the modality across data.

In my worksheet data the modality occurred 23 times. I observed very few modal verbs indicating uncertainty (could-twice) and the hedged form (may-three times). The frequencies of other modal verbs having strong certainty were more that the hedged words, for example, “can” occurred eleven times. This finding did not support the view that values students’ thinking and did not find students’ contributions meaningful.

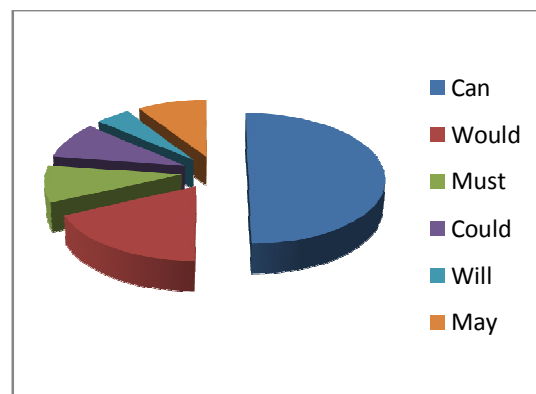


Figure 2 Frequency of question forms

### Discussion

The discourse analysis conducted in this work validates that language of worksheets is authoritative and position students out of mathematics community as they employ exclusive imperatives significantly more than inclusive imperatives. The exclusive language use appears in the use of question forms. Repeated use of “what” questions but not “which and why” questions creates unequal power relation between the teacher and the students, and restricts students to follow a particular algorithm and to find the correct answers. Worksheets tend to treat students as scribblers rather than thinkers [21]. This performance-based approach distances students from

comparing, reasoning, explaining, and relating activities and leads them to value mathematics as a science of abstract or as a mastery of calculation but not the art, the aesthetics, the discovery or the play.

In addition, findings of this work suggest that worksheets are lacking of singular and plural first person pronouns and very limited second person pronouns. This indicates teachers' (or worksheet authors') own voice was lost in the worksheets, which is also supported in the literature. Herbel-Eisenmann and Wagner (2005) say "[f]irst person pronouns (I and we) indicate an author's personal involvement with the mathematics. ... authors can use the pronoun I to model an actual person doing mathematics, and can draw readers into the picture by using the pronoun we" (p.123). Also, teachers detach students from themselves and "[set] a formal relationship between them" (Morgan, 1996, p.6). Limited use of pronoun and "obfuscation" (Herbel-Eisenmann & Wagner, 2005, p.125) of human agency promotes Platonist image of mathematics exposing mathematical activity apart from humans.

My analysis of modality use in worksheets also emphasised this absolutist view to mathematics as certainty is enforced through the dominant use of "can" meaning students' imagining or interpreting other possibilities within mathematics is disregarded [37]. This certainty pursues a fixed curriculum and puts barriers to children's and teachers' imagination and creation from their own real experiences and as a result engagement is lost. That view is neither open to children's own experiences and contacts with the world nor it is an effective tool to experience real mathematics as a powerful language of the imagination and creativity. However, worksheets may lead students to understand human knowledge is humanly constructed and students themselves have the power and potential to make their contribution [27].

As a result, worksheets revealed a world where the students' activities are very limited and they are encouraged circulate or fill the right answers but not provided with enough space to raise their own voice and to make their own contribution.

### Implications for pedagogy

The worksheets have played a role as a hegemonic and homogenizing force in the sense that they lead students to learn in one way, and treat them as cohorts rather than individuals without addressing individual abilities, interests and needs. Worksheets have mostly emphasized the procedural and

calculational aspects of mathematics but not conjecturing, relating, testing or describing nature of mathematics. That use of worksheets could put barriers to teachers' and their students' imagination and creation by closing a door towards exploration and by forcing a fixed curriculum [27]. Since most of the worksheets emphasize individualistic work rather than community work, the use of worksheets might ignore the importance of promoting learning in a social and cultural interaction through challenging others' ideas, and justifying one's own arguments [8, 9].

This associates to how Marks and Mousley (1996) invite mathematics teachers to use and allow students to use different genres like explanatory or expository genres other than recount genre. Solomon and O'Neill (1998) agree on this view and value a genre approach which worth "authorship and creativity" over the text (p.210). From these perspectives, it becomes important to promote different kind of activities by the use of different inclusive language forms and getting students interact with the text in an expressive way.

I also believe thinking out of the box when it comes to worksheet usage in the mathematics classroom aligns well with treating the learning activities of the classroom as full of intellectual vigor and bringing creative engagement into my mathematics. This is precisely what I am inspired to do in my practice.

### References

- [1] Altman, R. (1984/2003). A semantic/ syntactic Approach to film genre. B. K. Grant (Eds.), *Film Genre Reader III*. (27-41). Austin: University of Texas Press.
- [2] Appelbaum, P. & Gerofsky, S. (2012). Working Group report: The role of text/books in the mathematics classroom. Paper presented at CMESG, Quebec.
- [3] Artemeva, N. & Fox, J. (2010). Chalk talk: A principal genre of the university mathematics classroom. In H. Graves & R. Graves (Eds.), *Proceedings of the 25th Conference of the Canadian Association of Teachers of Technical Writing 2008*. (167-183). Edmonton, AB: Canadian Association for the Study of Discourse and Writing.

- [4] Artemeva, N. (2008). Toward a Unified Social Theory of Genre Learning. *Journal of Business and Technical Communication*, 22 (2), 160-185.
- [5] Bawarshi, A. S. & Reiff, M. J. (2010). *Genre: An introduction to history, theory, research, and pedagogy*. West Lafayette, IN: Parlor Press.
- [6] Bhatia, V.J. (2012). Critical genre analysis. Paper presented at Genre 2012 Conference, Carleton University, Ottawa, Canada, 26 June 2012.
- [7] Cawelti, J. G. (2003). Chinatown and generic transformation in recent American films. In B. K. Grant (Eds.), *Film Genre Reader III* (243-262). Austin: University of Texas Press.
- [8] Cobb, P. (1994). Constructivism in mathematics and science education. *Educational Researcher*, 23(7), 4–20.
- [9] Cobb, P., & Yackel, E. (1996). Constructivist, emergent, and sociocultural perspectives in the context of developmental research. *Educational Psychologist*, 31 (3/4), 175–190.
- [10] Devitt, A. J. (2004). *Writing Genres*. Southern Illinois University Press.
- [11] Dede, Y. (2006). Values in Turkish middle school mathematics textbooks. *Quality and Quantity*, 40(3), 331-359.
- [12] Erbas, A. K., Alacaci, C., & Bulut, M. (2012). A Comparison of Mathematics Textbooks from Turkey, Singapore, and the United States of America *Educational Sciences: Theory and Practice*, 12(3), 2324-2329.
- [13] Gerofsky, S. (1996). A linguistic and narrative view of word problems in mathematics education. *For the learning of mathematics*, 16 (2), 36-45.
- [14] Gerofsky, S. (1996). A linguistic and narrative view of word problems in mathematics education. *For the learning of mathematics*, 16 (2), 36-45.
- [15] Gerofsky, S. (1999). *The word problems as genre in mathematics education*. (Doctoral Dissertation). Retrieved from [http://www.collectionscanada.gc.ca/obj/s4/f2/dsk1/tape7PQDD\\_0027/NQ51864.pdf](http://www.collectionscanada.gc.ca/obj/s4/f2/dsk1/tape7PQDD_0027/NQ51864.pdf) February 12, 2012.
- [16] Gerofsky, S. (1999). Genre analysis as a way of understanding pedagogy in mathematics education. *For the learning of mathematics* 19(3), pp. 36-46.
- [17] Gerofsky, S. (2011). Ancestral genres of mathematical graphs. *For the learning of mathematics* 31(1), 14-19.
- [18] Gerofsky, S. (forthcoming). Analysing pedagogical genres in mathematics education: A multiperspectival method, and the example of 'worksheets as genre'. Submitted to *Educational Studies in Mathematics*.
- [19] Halliday, M. A. K. (1978). *Language as social semiotic*. London: Edward Arnold Press.
- [20] Halliday, M. A. K. & Martin, J. R. (Eds.) (1993). *Writing science: Literacy and discursive power*. Pittsburgh, PA: University of Pittsburgh Press.
- [21] Herbel-Eisenmann, B. A & Wagner, D. (2005). A framework for uncovering the way a textbook may position the mathematics learner. *For the Learning of Mathematics*, 27 (2), 8-14.
- [22] Herbel-Eisenmann, B. A. (2007). From intended curriculum to written curriculum: Examining the “voice” of a mathematics textbook. *Journal for Research in Mathematics Education*, 38(4), 344-369.
- [23] Hodge, R. & Kress, G. (1993). *Language as ideology* (2<sup>nd</sup> ed.). London: Routledge & Kegan Paul.
- [24] Krueger, R.A., & Casey, M.A. (2009). *Focus groups: A practical guide for applied research*. Pine Forge Press.
- [25] Marks, G. & Mousley, J. (1990). Mathematics education and genre: Dare we make the process writing mistake again? *Language and Education*, 4(2), 117-135.
- [26] Martin, J. (1985). *Factual Writing: exploring and challenging social reality*. Geelong, Vic.: Deakin University Press (ECS806 Sociocultural Aspects of Language and Education) [republished by Oxford University Press, 1989]

- [27] Mason, J. (2002). *Researching Your Own Practice*. London: RoutledgeFalmer.
- [28] Mesa, V., & Griffiths, B. (2012). Textbook mediation of teaching: An example from tertiary mathematics instruction. *Educational Studies of Mathematics*, 79, 85-107.
- [29] Miller, C. R. (1984). Genre as social action. *Quarterly journal of speech* 70(2), 151-167.
- [30] Morgan, C. (1996). "The language of mathematics": Towards a critical analysis of mathematics texts. *For the learning of Mathematics*, 16(3), 2-10.
- [31] Morgan, C. (1998). *Writing mathematically: The discourse of investigation*. London: Falmer.
- [32] Mousley, J. (2012). Shaping practice: worksheets as social artefacts. In *Mathematics Education Research: Innovation, Networking, Opportunity: Proceedings of the 26th Annual Conference of the Mathematics Education Research Group of Australasia*, Deakin University, Geelong, 6th-10th July 2003 (pp. 531-538). Mathematics Education Research Group of Australasia Inc.
- [33] Pimm, D. (1987). *Speaking mathematically: Communication in mathematics classrooms*. New York:Routledge&Kegan Paul.
- [34] Potamkin, C. C. (1963). An Experiment in Individualized Arithmetic. *The Elementary School Journal* 64 (3), 155-162.
- [35] Robinson, J. (2012). Using focus group. In S. Delamont (Eds.), *Handbook of qualitative research in education*, (391-404) Cheltenham:Edward Elgar Pub.
- [36] Rotman, B. (1988). Towards a semiotics of mathematics. *Semiotica*, 72 (1/2), 1-35.
- [37] Rowland, T. (1995). Hedges in mathematics talk: Linguistic pointers to uncertainty. *Educational Studies in Mathematics Education*, 29, 327-353.
- [38] Schryer, C.F. (2000). Walking a fine line: Writing 'negative news' letters in an insurance company. *Journal of Business and Technical Communication*. 14(4), 445-497.
- [38] Solomon, Y. & O'Neill, J. (1998) Mathematics and narrative. *Language and education* 12(3), 210-221.
- [39] Wallace, M. L. & Ellerton, N F. (2004). Language genre and school mathematics. Paper presented at Topic Study Group 25, International Congress on Mathematics Education (ICME) 10, Copenhagen, Denmark.
- [40] Wilson, S. M. (2002). *California dreaming: Reforming mathematics education*. Yale University Press



# Women's voices in English language education

Leila Otto Kajee

Faculty of Education, University of Johannesburg  
[lkajee@uj.ac.za](mailto:lkajee@uj.ac.za)

## Abstract

*Set against the backdrop of an education system in the new dispensation of South Africa, this paper identifies a gap in women's voices in education. The paper reports on the voices of pre- and in-service women teachers studying an English methodology course at a university in Johannesburg, South Africa. Located within a feminist pedagogical framework, the paper explores women's voices in relation to their education journeys and their views on classroom spaces and teacher-learner engagement. The qualitative case study uses narratives and interviews to elicit data from the selection of women participants. The paper concludes that lived experience and voices are critical in the educational endeavour, but are not without certain constraints.*

## 1. Introduction

The inequities that confronted education under the South African apartheid government are well-documented. Since the new dispensation in 1994, policies of transformation have introduced change at several levels in educational and other spheres. South Africa embraces the Education for All goals, as well as the Millennium Development goals. Issues surrounding poverty and curriculum reform are being addressed, as are early childhood and adult basic education, and HIV/Aids in policy reforms. Girls are performing well in Grade 12, and more girls are in higher education: 44,1% in 1993 to 51% in 1999 to 54.3 % in 2001 (Ministerial Report, UNESCO, 2005 [21]). However, there are still noticeable gaps that appear in the transition to the workforce, which confines women to low-paying, unskilled jobs.

In 1996 the country established a Gender Equity Task Team (GETT), set up to make recommendations on how to take the gender agenda forward. The result was one of the most comprehensive reports on gender and education in the country (Wolpe et al...). However, since the emergence of the report many of

the recommendations made in the report remain symbolic (Chisholm, 2001 [3]). The discrepancy remains between policy and practice, aptly put forward by Chisholm (2003) [4] who argues that much of the gender machinery that was established was "dismantled and disempowered" (2003: 4).

Therefore severe inequities surrounding education remain: lack of infrastructure and basic services, children travelling long distances to school, often on foot, poor quality of education including large classes, unqualified teachers, lack of resources, poverty and hunger. Many of these challenges exist, but are far from confined to rural areas. They are prevalent in previously disadvantaged communities. So, although South Africa is making progress in terms of its figures, unlike other Third World countries, it still faces iniquitous challenges, and while significant strides have been made socially, politically and economically in terms of gender equity (Chisholm and September, 2005). there is room for substantial work in the field. In fact, as Chisholm and September (2005) [5] argue, gender equity is not only about access, meeting gender figures, or only about affirming women. Therefore, the Gender Equity Task Team Report defines gender equality as:

"Meeting women's, men's, girl's and boy's needs in order for them to compete in the formal and informal labor market, to participate fully in civil society and to fulfil their familial roles adequately without being discriminated against because of the gender" (Wolpe et al, 1997 in Chisholm and September, 2005: 3) [5].

Among its considerable review of recommendations, the report includes the need for work on identities in and outside the curriculum. As the report re-iterates, girls' access to education is not the greatest challenge in the country, more important is the quality of girls' participation in schooling. Thus women's voices are fairly silent.

## 2. Research aims and questions

Given several realities, this paper explores the voices of women in-service and pre-service teachers who are studying an English Methodology course at a university in Gauteng, and their journeys through education in the South African context. The paper gives rise to several concerns: How can women's educational lives and experiences be mapped? What are the barriers and constraints that they face? How can an understanding of women's lives and experiences feed into the curriculum? What will an understanding of women's identities and barriers provide to the South African contexts? The aims of this paper, while multiple, focus primarily on the stories women tell, with regard to their education journeys, and their views on classroom spaces and engagement.

## 3. Theoretical framework: Feminist pedagogy

The study is theoretically framed in feminist pedagogy (FP), drawing on gender and identity. "As feminist pedagogy enjoys increased adoption, notions about feminism itself are changing and thus opening up a wide range of ways to be feminist and to do feminist scholarship" (Thompson and Walker, 1995: 848 [20]). Feminist pedagogy is a theory about the teaching/learning process that guides our choice of classroom practices by providing criteria to evaluate specific educational strategies and techniques in terms of desired goals or outcomes (Shrewsbury, 1993 [19]). As a theory about teaching and about the democratic construction of knowledge, key ideas centring around feminist pedagogy include learners' taking responsibility for their own learning, and contributing to knowledge construction. The evaluative criteria include the extent to which a community of learners is empowered to act responsibly toward one another and the subject matter, and to apply it to social action. Thus feminist pedagogy begins with a vision of what education might be like but often is not (Shrewsbury, 1993 [19]). Feminist teachers see the classroom as a liberatory environment, with teachers and students as subjects engaged with the self in reflective practice, actively engaged with material, engaged with others in a struggle to get beyond our sexism, racism, homophobia and other destructive hatreds and to work together to enhance knowledge. Thus strongly emphasised is engagement with community and movements for social change. The classroom becomes a net of relationships with people who care

about each others' learning. One goal is that members respect each other rather than fear them. As Shrewsbury (1993:6 [19]) puts it: "The web of interrelationships in the classroom is seen to stretch to the local, regional, and global communities and, potentially even beyond the boundaries of our earth". The liberatory environment builds on participants' experiences, their social lives and lived experiences, their voices, their possible resistance.

### 3.1 Central concepts

In essence the central concepts underpinning FP include: reformed relationships between the teacher and student; empowerment; community; leadership; privileging individual voice; respect for individual voice as a way of knowing; and diversity of personal experiences (Shrewsbury, 1993 [19]; Webb, Allen & Walker, 2002 [22]).

**Reformation of relationship between teacher and student:** Within the context of FP are new roles between the teacher and student. With learners assuming more responsibility for learning, power is shared, however Christie (1997) [6] notes that traditional patriarchal education systems and deeply embedded norms can hamper even stultify this reformation, therefore they must not be underestimated. The notion of reformation ties up nicely with community-building in the classroom. The classroom becomes an active collaborative space where risk-taking is encouraged; where intellectual excitement abounds; and where power is viewed as energy, capacity, and potential, rather than domination. In reforming relationships a new form of rhetoric is that the teacher must not underestimate the pervasive effect of patriarchal education on learners. Teachers and learners must adopt new forms of invitational rhetoric (Foss & Griffin, 1995) [9]. Invitational rhetoric opens relationships that do not attempt to change, rather to validate in spaces of safety and value.

**Empowerment** is a primary goal of FP, involved as it is with principles of democracy and shared power. In its focus on empowerment, feminist pedagogy has links with Freire's dialogical education. It recognizes that limitations of meaning of the concept power in traditional schooling embody domination, thus the focus on empowerment, that is, power as energy, capability and potential rather than domination. Shrewsbury (1993 [19]) reminds us that to be empowered is to recognize our abilities to act to create a more humane social order; to be able to



engage in significant learning; and to be able to connect with others in mutually productive ways.

Empowering strategies therefore allow students to find their own voices without dissolving the authority or the power of the instructor. In such a system the teacher's knowledge and experience is recognized and is used with the students to increase the legitimate power of all.

The principles of democracy and shared power prevail, with feminist pedagogy challenging the view that education is a neutral cognitive process. Education either functions as an instrument facilitating students' integration and conformity into the present system or becomes the practice of freedom teaching men and women to deal critically and creatively with reality and to learn to participate in transforming their world (Middlecamp and Subramaniam, 1999 [12]). Any patriarchal model generally neglects empowerment, feelings and experiences.

**Community:** Students participate in our classes as individuals, taking little responsibility for the class as a whole. The classroom has a set of rules about fairness and equity but little consideration of differences in need. The rights of others in the classroom are respected, but little compassion and care is structured into the classroom. At the core of feminist pedagogy is a re-imaging of the classroom as a community of learners where there is both autonomy that is congruent with the developmental needs of both women and men. Students may find connections with themselves, their individual and collective pasts, with others, and with the future. In such a classroom there is a need and desire to move learning beyond the walls of the classroom. Theory can be extended to action, and action can come back to inform theory and that can lead again to action.

FP is concerned with building community and cooperation within the classroom as well as between the classroom and broader environment. Community of growth and caring is key in critical feminist education (Scering, 1997 [16]). Building trusting environments in which all members are respected and have equal opportunity to participate is central (Schniewind, 1993 [17]). Collaborative learning occurs through relationships and dialogue, and assumes learners to be active in their meaning-making, thus giving individual speakers power unusual in a hierarchy. Collaborating on tasks creates a learning community, such as service learning projects.

**Leadership:** FP focuses on the development of leadership. For example, students who take part in

developing goals and objectives for a course learn planning and negotiating skills. They also learn how to develop an understanding of, and an ability to articulate, their needs. They learn how to find connections between their needs and the needs of others. They learn about groups and about the different leadership tasks in groups and take different leadership roles throughout the course period. The feminist teacher is above all a role model of a leader. S/he has helped members of the class develop a community, a sense of shared purpose, a set of skills for accomplishing that purpose, and the leadership skills so that teacher and students may jointly proceed on those tasks.

**Privileging individual voice as a way of knowing:** Feminist pedagogy encourages authority in others, sees knowledge as constructed and culture bound, allowing different classroom dynamics and voices to emerge (Middlecamp and Subramaniam, 1999 [12]). Thus voice in teaching is a primary issue.

**Respect for diversity of personal experience:** FP challenges hierarchal relations of schooling and involves social bonding (Scering, 1997 [16]), while privileging personal lived experiences and validating them (Chapman, 1997 [2]; Foss and Foss, 1994) [10]. Respect, empathy, and critical thinking are foregrounded. One goal of the liberatory classroom is the respect for difference (Shrewsbury, 1993).

**Challenging traditional views:** Knowledge and teaching methods are not value free. Traditionally, schools reproduce and reinforce the social construction of gender through nurturing autonomy, masculinity and femininity. Feminist teachers challenge the origins of these ideas and theories.

## 4, The study

### 4.1 The course

The Contentious Issues in Language course in the Bachelor of Education degree and Post Graduate Certificate in Education course at the university is a final year course taken by students pursuing an education degree. The course content covers language issues pertinent to future teachers including the landscape of multicultural and multilingual elements of our society, and its significance for language learning, language and identity, language and gender, language and power, and the changing language learning environment. One of the challenges of the course is trying to align the experiences of students who have spent three years immersed in an education degree, as well as those who, after spending three years in an undergraduate

humanities programme, with notions of education. The attempt therefore was to facilitate the class as a community. This fed effectively into core notions of feminist pedagogy, as shown above. There were twenty women participants in the study, aged between 22 and 45. Fifteen were pre-service teachers, and five were in-service teachers. Pseudonyms are used throughout the study for ethical reasons.

#### 4.2 Research approach and methodology

This research is a qualitative case study, the aim of which is to examine the experiences of women students in a language course using data collection methods such as interviews and narratives. Interviewing is a valuable source to access the participants' views. The main purpose of an interview, according to Henning, is "to bring to our attention what individuals think, feel and do and what they have to say" (2004: 52) [11] about their experiences and opinions. In this regard, both focus group interviews and individual interviews were conducted. Focus group interviews are beneficial to encourage debate and discussion among the participants, while individual interviews give the participants more privacy and freedom to express what they really think. The interviews were voice recorded and transcribed.

According to Clough (2002: 8) [7] narrative is useful to the extent that it opens up (to its audiences) a deeper view of life in familiar contexts: it can make the familiar strange, and the strange familiar. He continues that stories are a means by which truths may be uncovered, providing an element of anonymity without stripping away "the rawness of real happenings".

#### 4.3 Some findings and discussion

In this section, extracts from narratives and interviews relevant to the research aims and questions are presented, then discussed.

##### 4.3.1 Mapping the women's lives: Convoluted education journeys

For many of the women, the education journey was neither simple nor straightforward, and several felt disenfranchised along the way, as the following extracts demonstrate:

*"I am a mature woman who returned to university after a long gap in my studies. I was just now appointed as a head of department at my school,*

*where I taught grade six learners. I have a long history in the field of education, including spending two years in China where I taught English as a second language. Mine was not an easy journey at all. It was a struggle to get educated then, it is a struggle to get educated now. Women have more responsibilities, especially if you are older, and you are not always taken seriously, even if teaching is considered a woman's job, as I was told, but I love to teach" (Desiree).*

*"It was teaching or nursing in those days, maybe even now, I thought teaching would give me more holidays, and I needed the bursary, or else who knows what I would do? Now I do enjoy it, but at the beginning as a new teacher you are taken for granted by especially male teachers and headmasters. They expect you to do everything, but it is worse when another woman takes advantage or becomes jealous that the learners like you, or if you are doing well. Then at home it is chores, kids, husband, even if you are studying (Gladys).*

*"I am an immigrant, I come from Nigeria. It was fine in Nigeria to study, but now I am here (in South Africa), for many different reasons. I am seen as someone different, as someone with a funny accent who won't be understood in the English class. So I had to fight just to study, boys were given more opportunity, so I thought teaching would satisfy" (Doris).*

*"Afrikaans is my first language, people still look at me like I am the enemy. I just want to teach children. I don't think my history should come into it, but in South Africa you become the marginalised if you are white and Afrikaans speaking. Then the women-thing comes into it." (Sonja).*

It is apparent that while certain women wanted to teach (Sonja, Desiree), others stumbled onto education as a profession (Gladys, Doris). Despite a long career as a teacher, Desiree still finds herself enmeshed in family responsibilities, and the stereotypical view that teaching is a women's job. Like Gladys, she is expected to play multiple roles: wife, mother, teacher. She comments too about the two stereotypical career choices for women at the time she made her choice: teaching or nursing. These were typical choices for black women in particular in South Africa, considered suitable for women. However, her decision to complete her studies at this stage is evident that she is currently comfortable with it, or has grown into it. Doris appears disenfranchised in two ways: being an immigrant, and her use of English as an additional language. She appears disgruntled that her ability as a teacher could be

influenced by her accent. Such views are notable among black African immigrants, not least because of the recent spate of xenophobic attacks experienced in the country. Sonja is happy to teach, but comments on possible racism against her because of her being and speaking Afrikaans. Historically, Afrikaners were seen as the architects of apartheid in the country, and are still often resented for the role they played. She dismisses gender as a third obstacle, and perhaps less important. It is also significant that three of the older women, Desiree, Gladys and Doris have returned to university to complete their studies. Doris said “Without a degree I won’t be taken seriously, or considered worthy”. To Gladys it was a question of “completing her journey”.

### 4.3.2 Barriers and constraints

Barriers experienced by the women were mostly typical. Lane and Cheryl, two younger women felt their studies were very intensive, which took up a lot of their time. Both mentioned the demanding workload of assignments, reading and lesson preparation. As single women without children, they felt they would not have coped as new teachers if they were married or had children. Lane, who helped support her parents because her father was unemployed at the time of the study also felt the money she earned through her part-time teaching and tutoring was insufficient. She said in her interview “You work all the time but don’t really see any money for your effort, but it’s not about the money, but the love”.

Doris commented on her efforts despite having a family to look after, and males in her family being given study-preference. To her, her Nigerian accent also appeared to be a constraint as provided in the section above. The women who were mothers felt particularly burdened. “They say as a teacher your children are lucky, you can help better with homework and studying, but off course this is not always the case, you have to see to all your other work first before you can do that” (Melanie).

Some of the biggest challenges came from three women who had been brought up in impoverished homes. They spoke of financial difficulties of being a student and student teacher: the lack of money for books, resources, clothing, transport and food. Xoliswa spoke about when class finished late and she could not get a taxi home, she would sleep over with friends who had parties, and who would insist she drink alcohol, which she would resist. She once slept over on campus in the library, which was not

permitted. However, she felt she had to persevere in order to show her community what she had achieved. Community pride is felt very strongly in African communities, with communities sometimes helping to support students in any way they can.

### 4.3.3 Re-imaging the classroom: Power sharing and community building

Many of the women felt that they had a unique contribution to make to the classroom. For several, it was about flattening hierarchies so that they could build communities in the classroom. As Shrewsbury (1987 [18], 1993 [19]) discusses, at the core of FP is a re-imaging of the classroom as a community of learners where there is both autonomy of self and mutuality with others that is congruent with the developmental needs of both women and men. Cheryl said it was important to “respect learners as they respect (you). The learners too need power, it’s not only about the teacher being in charge. When learners take charge of their learning they learn more effectively. Teachers are not the enemy, but some teachers feel they must be superior always. The classroom must be a safe space”.

Genna said “The classroom must be intimate, bright and cheery. It is a place away from home. It must have a good feel. There is a unique relationship between teachers and learners. There must be trust that even if as a learner you say the wrong thing you will not be teased and laughed at. Learners must bring their experiences to the classroom. Each learner is different, the classroom is noticeably diverse.” As Weiler (1988 [23]) says, feminist pedagogy is characterised by an emphasis on lived experience and the significance of everyday life, as well as the multiplicity of truths and value of diversity. Parry (1996: 46 [13]) too highlights the value of diversity when he elicits that it makes explicit that how we experience and understand things and is rooted in our social position, based on a variety of factors, including gender, race, ethnicity, class, and sexual preference”. And as Bowker and Dunkin (1992) [1] remind us, it is the teacher’s task to introduce the personal as knowledge without sacrificing the credibility of the teaching-learning process.

## 5. Conclusion: Women finding their voices

What is the value of women’s voices, and what are the implications for teaching and learning? In the Contentious Issues in Language course, we tried to create a classroom based on the principles of feminist pedagogy, by theorising classroom diversity, and is

so doing, giving women their voices and exploring the value of their lived experiences in their chosen profession. Examining their views on the classroom as a safe space for teaching and learning language highlighted the role of diversity and their struggles to enter and make their footprint in their chosen profession.

Any liberatory environment suggests a new way to engage with one another. If the classroom is an intricate web of relationships with people who care about one another's learning, members should respect one another, rather than fear them. "The web of interrelationships in the classroom is seen to stretch to the local, regional, and global communities and, potentially even beyond the boundaries of our earth"(Shrewsbury (1987: 6 [18]). Perumal (2006 [14]) feels that mainstream pedagogy silences voice and denies acknowledgement of their experiences, therefore voice and personal experience is encouraged, rather than complete reliance on the abstract. She cautions however that the traditional should not be ignored but critiqued for its gaps and silences, and that while narratives should be encouraged, they are also problematic because of possible trauma they could cause to certain participants because of opening their lives to scrutiny.

We may also question if we have the right to raise students' consciousness, and to manipulate their ideological perspectives. Does every student have something valuable to say? Some views may be "calcified in a kind of mono-vision that is racist, sexist, while also harbouring prejudicial ideologies"(Perumal, 2008: 296 [15]). Therefore Perumal advises that we rather use them as entry points, given that no one has a single voice or identity.

Shrewsbury (1993) reminds us, FP is transformative and helps us revise the educational enterprise and is a crucial component of a feminist revolution.

#### Reference list:

[1] Bowker, J.K. & Dunkin, P.R. (1992). "Enacting feminism in the teaching of communication. In L.A.M. Perry, L.H. Turner & H.M. Stern (Eds.), *Constructing and reconstructing gender: the links among communication, language and gender* (pp. 261-268). Albany: State University of New York Press.

[2] Chapman, E. (1997). "Nurse education: A feminist approach"*Nurse Education Today*, vol. 17, pp. 209-214.

[3] Chisholm, L. (2001). Gender and leadership in South African educational administration.*Gender and Education*, 13(4), 387-399.

[4] Chisholm, L. (2003). "The politics of curriculum review and revision in South Africa".In *Oxford International conference on education and development*, pp. 9-11.

[5] Chisholm, L., & September, J. (2005). "Gender equity in South African education: 1994-2004". In *Conference Proceedings*, Cape Town: HSRC Press.

[6] Christie, A.A. (1997). "Using e-mail within a classroom based on feminist pedagogy"*Journal of Research on Computing in Education*, vol. 30, pp. 146-176.

[7] Clough, P. (2002).*Narratives and fictions in educational research*. Open University Press: Buckingham

[8] Department of Education (1997) Gender Equity in Education: Report of the Gender Equity Task Team (Pretoria).

[9] Foss, S. K., & Griffin, C. L. (1995). "Beyond persuasion: A proposal for an invitational rhetoric"*Communications Monographs*, vol. 62, no. 1, pp. 2-18.

[10] Foss, K.A. & Foss, S.K. (1994). "Personal experience as evidence in feminist scholarship"*Western Journal of Communication*, vol. 58, pp. 39-43.

[11] Henning, E. (2004). *Finding Your Way in Qualitative Research*.Pretoria: Van Schaik Publishers.

[12] Middlecamp, C.H. & Subramanian, B. (1999). "What is feminist pedagogy? Useful ideas for teaching chemistry" *Journal of Chemical Education*, vol. 76, pp. 520-525.

[13] Parry, S.C. (1996) "Feminist pedagogy and techniques for the changing classroom"*Women's Studies Quarterly*, vol. 24, no. 3/4, pp. 45-54.

[14] Perumal, J. (2006). "Authority as authorship: teacher and student personal narratives in the English

language class” *Southern African Linguistics and Applied language Studies*, vol. 24, no 4, pp. 537-552.

[15] Perumal, J. (2008). “Student resistance and teacher authority: the demands and dynamics of collaborative learning” *Journal of Curriculum Studies*, vol. 40, no. 3, pp. 381-398.

[16] Scering, G.E. (1997). “Themes of critical/feminist pedagogy: teacher education for democracy” *Journal of Teacher education*, vol. 48, pp. 62-68.

[17] Schniedewind, N. (1993). “Teaching feminist process in the 1990s” *Women’s Studies Quarterly*, vol. 21, no. 3/ 4, pp. 17-20.

[18] Shrewsbury, C.M. (1987). “What is feminist pedagogy?” *Women’s Studies Quarterly*, vol. 15, no. 3/ 4, pp. 6-14.

[19] Shrewsbury, C.M. (1993) “Feminist pedagogy: An updated bibliography” *Women’s Studies Quarterly*, vol 21, pp 8-16.

[20] Thompson, L. & Walker, A.J. (1995). “The place of feminism in family studies” *Journal of Marriage and Family*, vol. 57, pp. 847-865.

[21] UNESCO (2005) “Education for all: Global Monitoring Report”. *UNESCO Ministerial Report*.

[22] Webb, L.M.; Allen, M.W.; Walker, K.L. (2002). “Feminist pedagogy: identifying basic principles” *Academic Exchange Quarterly*, Spring 2002.

[23] Weiler, K. (1988). Women teaching for change. New York: Bergin & Garvey.

# Egoistic Suicide: Suicide Factors Among Indian Youths

Rakesh Choudhary

Department of Social Work, University of Lucknow, India  
[Rakeshchoudhary1808@gmail.com](mailto:Rakeshchoudhary1808@gmail.com)

## Abstract

*Suicide among the young is an acute worldwide issue, and it has become an epidemic in Asia where high suicide rates in several highly populated countries have accounted for the greater part of the world's suicides. Anomic suicide has been used in describing India's suicide where less regulation is perceived by the youths in current fast changing society. This study aims to investigate young people's perspectives about death – to discover from them the possible factors giving rise to high incidences of suicide among teenagers and young adults and to possibly explain the suicidal situation in India. Two hundred and fifty youths aged 15 – 24 from various schools, colleges and hospitals in India were recruited for this study. SPSS was used to analyze the statistic figures for frequency count and Chi-square test for independence was conducted. The findings show that youngster mostly sought help from their friends. The possible main factors for suicide revealed by the participants were: Coping with boy-girl relationships, family issues and stress from school work. A high percentage of participants indicated life was self-determined, and this revealed the changing values among the teenagers that might have contributed to the high suicide rate. Suicidal situation in India is therefore more social related. Being able to be integrated into the immediate context and society for youths is thus needed, rather than just lacking of social regulation.*

## 1. Introduction

Suicide among young is an acute worldwide issue as it has become the third leading cause of death among youth aged 10 – 24 in the United States [1]. The loss of young lives who are still at their growing up stage, yet to fully emerge into adulthood is a tragedy to human mankind and it is really a heart breaking issue. India is located in South East Asia whereby this global tragedy has become an epidemic. According to the report from World Health Organization this epidemic of suicide among young people has accounted for a greater part of the world's

suicides [2]. The suicide rate among the young people is shocking in India. It keeps increasing. It was found that almost 10% of the adolescents experienced suicide ideation and more than half of them turned their thoughts into action. The suicide rate in India has been increasing steadily and has reached 11.2 (per 100,000 of population) in 2011 registering 78% increase over the value of 1980 (6.3).

Due to difficulties in identifying a death as suicide and other issues such as claiming of insurance and dealing with family shame, the above figures could be under reporting. In actual suicide rate in India should be much higher.

Emile Durkheim (1859/1960) conceptualized suicide issues from a sociological perspective. According to his classification, there are four different types of suicide, namely altruistic suicide, anomic suicide, egoistic suicide and fatalistic suicide. Thorlindsson and Bjarnason (1998) further analyze Durkheim's initial concept, —"too little integration leads to a state of loneliness and egoistic suicide; Too much integration leads to altruistic suicide when the perceived interest of the social group is set above personal interests; Under regulation causes anomic suicides of individuals lost in a chaotic universe; Over regulation results in fatalistic suicides." [3]. From the above analysis of the possible etiologies, both integration and regulation are needed. However, too much or too little can be harmful for human development. Integration cultivates social bonds and it gives a sense of belonging for individuals; whereas regulation provides guidance thus ensures safety for individuals to prevent a sense of —"lost in a chaotic universe".

The Indian's suicide cases were analyzed by Adnan [4] from a sociological perspective. He attributes the rising suicide rate to two major factors: First, poor coping mechanism for the stresses of school life and, second, the lack of a programme to promote good mental health in the country. His perspective and description of India's suicide trend among the young people was similar to Durkheim's —Anomic suicide, which refer to the lack of

regulation among the young people. Adnan highlighted risks factor such as instability in society, the absence of family/religious protecting factors that have contributed to the rising rate of suicides cases in India. It seems logical that a sudden removal of excessive regulation or control as a result of social change will give rise to anomic behaviours. This paper argues that suicide as a global social issue may be more complicated than expected. A linear equation or a simplistic classification of etiology may not be sufficient to pin down the causal factors of suicide. As a result of globalization, young people in India are no longer living in a closed community that can be immunized the globalized effects of feeling lost or feeling chaotic. As individuals are developed in a context which operates within various layers such as microsystem (refers to immediate family system), exosystem (schools system and community), exosystem (systems within systems) and macrosystem (a larger cultural system) Regulations may provide safety or security so that young people knows the guidelines about what to do and how to conduct their lives in the community. However, sense of belonging, being able to integrate into the society is equally important as it was found that family integration and parental regulation bring similar impact on youth's suicidal ideation and behaviour [3].

## 2. Methodology

A total of 270 students comprised of 127 males and 143 females aged from 15 to 24 from different parts of urban west India were recruited. The participants were from different government secondary schools and university campus across different regions in India. A questionnaire was designed to find out their perceptions of death, and if they were prepared to discuss their views on the reasons for suicide among youth. Permission for the study was obtained from the gate keepers of relevant authorities in the various organizations taking part, who were the principals of secondary schools and administrative authorities from local universities. The participants were informed on their right to withdraw from the study if they felt the questions were intrusive or difficult to answer. Sensitivity and confidentiality were also noted and participants were informed that only group data would be used for publication and no personal information, nor the name of their schools or organization would be revealed. Token of appreciations were given to

participants who had completed the whole questionnaire.

**TABLE 1: GENDER AND AGE OF PARTICIPANTS**

Gender	Frequency	
MALE	Below 18	95
	18 and above	32
	Total	127
FEMALE	Below 18	143
	18 and above	86
	Total	57

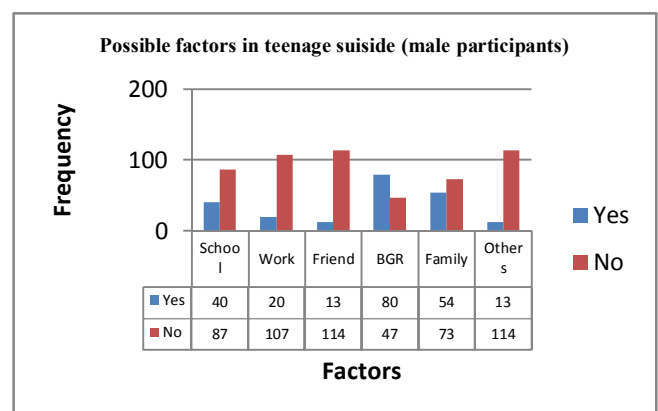
## 3. Findings

The findings suggest that most students are open to discussion about the topic of death. They mostly discuss it with their friends. Males are likely to attribute the reason for suicide to boy-girl relationships; this is similar across all ethnic groups.

### 3.1. Possible Factors for Teenage Suicide

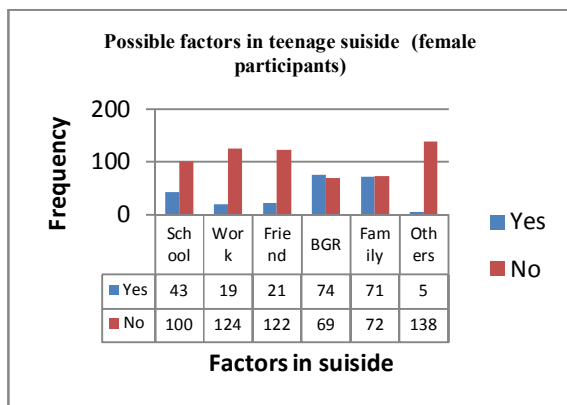
Three sources of stress that might have been caused for suicide for the young people were identified, namely boy-girl relationships, family issues and school work.

**Fig. 1. Male participants views on the possible factors in teenage suicide**



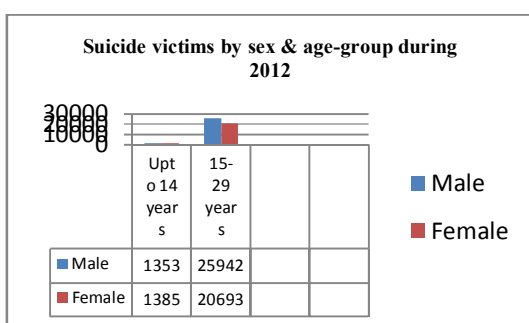
Boy-girl relationships ranked the highest for the possible reasons for suicide for both the male and female students.

**Fig. 2 . Female participants views on the possible factors in teenage suicide**



Eighty out of 127 (63%) of male participants and 74 out of 143 (52%) female participant stated BGR as the possible reason for suicide. More male participants than female participants think BGR issues contribute to suicide. Seventy one (around 50%) females stated family issues as a possible reason for suicide. Male students' answers were comparatively lower on family issues. Only 54 (42.5%) of male students stated family issues as a possible suicide reason.

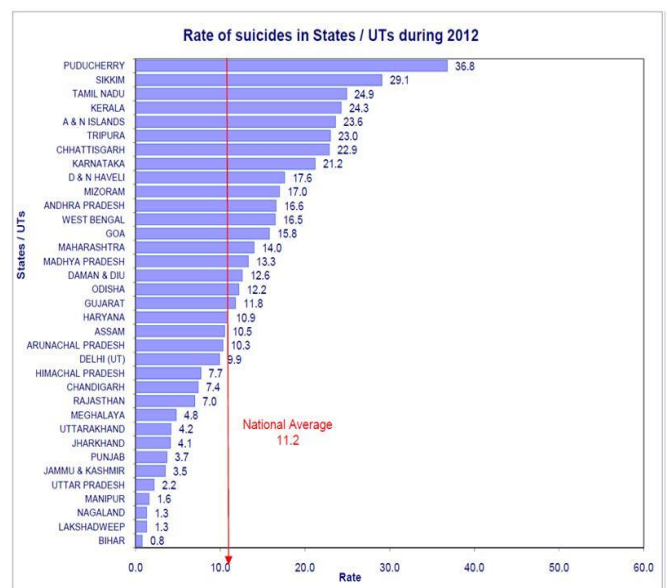
**Fig. 3. Age and gender wise profiles of those who died by suicide in India (Year: 2012)**



**Fig. 4. Trend in Rate of Suicides in India 2000-12**

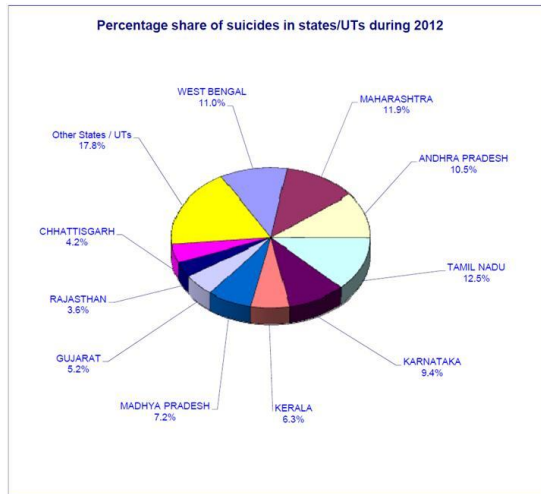


**Fig. 5. Suicide Rates in various States of India (Year: 2012)**





**Fig. 6. Percentage share of various states of India in incidence of suicides (Year: 2012)**



#### 4. Discussion

This study discovers three sources of stress identified by participants as possible factors in teenage suicide: boy-girl relationships ranked the highest, followed by dealing with family issues and stress from school work. The finding shows that young people will not avoid the topic of death. They will seek helps from friends and teachers were people of last resource.

Coping with boy-girl relationship is common for young people at this stage of development. However it can present enormous stress especially for male participants when emotional support is not available especially when the relationship does not work. It is particularly true and has presented as a potential source of stress for male participants as shown in this study. Durkheim's suicide theory [4] has depicted males as always more vulnerable in dealing with relationship hence their risk of suicide is considerably higher. The findings seem to be in line with Durkheim's postulation as the male students are more emotionally vulnerable. High percentage of male participants indicated that a broken relationship as a factors for suicide. There are some gender differences found in this study and it is supported by other literature that women tend to use suicide as -cry for help'[5]. Men would normally use drastic action when come to suicide behaviors. It could be explained by the male reluctance to share their

personal problems with others when they experience emotional disturbances. Instead, they opt for serious suicide action.

The second factor identified in suicide was family issues. Families are bound to face a lot of changes as a result of social change. The society nowadays is getting increasingly competitive, fast-paced, full of uncertainty, rapid change, insecurity and risk taking. Most families are dual income family and parents are busy with work. Hence children are pretty much left on their own. Adnan [4] attributes suicide to an unstable context, in which our youths are growing up, and which includes a lot of risk factors. Some of those factors identified in this study were the stress of coping with boy-girl relationships and school work. Moreover, the family itself becomes a source of stress for the young people. This seems to confirm the Adnan's postulation of external environment factors, especially changing of family setting and traditional values. Durkheim might describe those factors which arise from a state of dissatisfaction due to external stress that influence the family settings as anomic suicide.

The third factor in suicide is school environment. Young people spend most of their time in school, and school is supposed a place to help in their development. Instead of cultivating positive attitude towards life, it is always a place of stress for most students. The findings from this study reveal that more students cited stress from school work as the main factor in teenage suicide. This is supported in the literature that education is most valued in traditional Chinese families and can be traced back from Chinese Confucian beliefs [6], Indian Chinese families are no exception. Will Durkheim describe school stress factor as anomic?

We could explain the suicide cases in India according to the framework initiated by Durkheim's theory and further supported by Adnan's postulation. Meaning, it was due to the lack of regulation that our young people feel that they are not able to cope with boy-girl relationships, the stress coming from educational system and family stress. However, the reality of suicide as a global social issue could be more complicated. To look it from another perspective, it is equally logical if we explain it in another way: It was due to the lack of social bonds that our young people were not able to cope with boy-girl relationships, feel being lost in an increasingly stressful school environment and not able to be integrated in the current family and social system. It seems that —Anomical suicide is not

sufficient to explain the suicide cases among young people in India.

It is supported by the literature that family attachment reduces the possibility of attempted suicide among the young. Only young people who are raised by warm and caring parents are more able to have felt the warmth and care, thus less likely to yield to anomie and suicidality [3]. So, it is not only the lack of regulations, as regulations without warmth and care will breed hatred. Regulations normally refer to rules and controls. It is important not to minimize the complexity of the modern society. This modern society describe by Bauman as liquid modernity which is —slippery, shifty, evasive [7]. Coping with modern lives which are full of uncertainties, fears and potentially chaotic situation, it is bound to feel lost and lack of sense of belonging. It is both the family integration and parental warm and firm guidance that could save our young people from having suicide ideation. With the guidance of warmth and caring parents, family will serve as a resource for young people instead of a source of stress that lead to suicide behaviours. Nevertheless, as a result of current social changes and economic forces, not only fathers, but Indian mothers have been coerced into going to work in order to earn a better living [8], ensuing this protective factors may no longer exist.

Similar analysis applies to the school integration and social integration. When students being constantly failed by a school system; or as a family member who do not feel the warmth and care of a family; or as a member in the society who are not able to adapt to the societal change, the risk factors will be there. There will be no sense of belonging, self-image and self pride will be under attacked, and it will definitely affect their meaning in life.

A high percentage of participants, regardless of different ethnic groups, indicated that —Life is determined by self instead of —by others. Does it indicate that our young people are more self-focus? Does it mean that the young people nowadays perceived they should be in control whereas in reality they are not in control? However, they want to be in control of their lives. The findings of this result may indicate that young people are increasingly reacting with dissatisfaction to the way they are regulated by society, such as the school system and the societal changes.

It was certainly not entirely due to the lack of regulation, but may also due to the lack of integration into this forever and increasingly changing values in the society. Young people experience lack of

integration into the school, relationship, community or society they are living. The lack of control in their own lives causes them to feel insufficient and unable to cope when faced with uncertainties. This lack of integration into the environment where the individuals are located should be classified as —Egoistic Suicidal according to Durkheim's definition. However, it will be too simplistic to draw such conclusion. Firstly, suicide as a tragic social issue is certainly more diffuse and more complicated than such a scientific four dimensions theoretical framework could explain. Secondly, this is an increasingly individualized society, the need to be one self and the need to feel belong to the society are co-existing.

This phenomenon also shows that the values of collectivism are increasingly changing to individualistic ones. This fading away of traditional protective factors such as family, collectivism and religious norms are the immediate eco-systemic environments in which our young people are living nowadays. These findings are in line with Adnan's perspective that the weakening of collectivism values no longer serve as protecting factors that shield our young from ending their lives once they feel there is an absence of meaning in their lives. Therefore they are able to make decision to end their lives when they are not able to cope. One of the positive discoveries from this study is the self-focus individuals are very much in needs of friendships. Friendship and relationship are important for young people. It is evident in the findings that friends are the people most relied upon by the young people in times of need. Hence, developing peer support leaders in the school counseling programme could be effective in reducing suicide rates among the young. Mentoring and coaching by peer support leaders could be effective [8] as peer support programmes are found to be helpful in providing positive influences in the areas of academic and non-academic situations. Peers have a greater impact on their fellow pupils in that they serve as guides and role models. Also, working towards strengthening family ties with our young people in order to be able to offer help when needs arise is important.

## 5. Conclusion

Suicide as a social pathology requires preventive measures in the social context in which suicidal individuals are located. . Anomic or Egoistic? There is no simple answer to this question. This paper

reveals the perspective of young people on the issues of suicide and death. Various possible causes for suicide were identified by the participants. It is hoped that further investigation could be carried out to better understand our young people from their perspectives, and the numbers of tragedies among suicidally unhappy young people might be reduced.

## References

- [1] K. M. Lubell, S. R. Kegler, A. E. Crosby, and D. Karch, —Suicide trends among youths and young adults aged 10--24 years – United States, 1990—2004,‡ Division of Violence Prevention, National Center for Injury Prevention and Control, vol. 56, pp. 905-908, Sep. 2007.
- [2] H. Hendin, —Introduction: Suicide and suicide prevention in Asia,‡ World Health Organization, Department of Mental Health and Substance Abuse, 2008.
- [3] T. Thorlindsson and T. Bjarnason, —Modeling durkheim on the micro level: A study of youth suicidality,‡ American Sociological Review, vol. 63, no.1, pp. 94-110, 1998.
- [4] Wong. Interview with Adnan. The Stars. Retrieved from <http://www.thestars.com.my>. February 10, 2011.
- [5] J. Langhinrichsen-Rohling, J. Friend, and A. Powell. Adolescent suicide, gender, and culture: A rate and risk factor analysis. *Aggression and Violent Behavior*, 14(5), 402-414, 2009.
- [6] S. Jimerson. (n.d.). Adolescent development: Current issues. Retrieved from <http://education.indiana.edu/cas/adol/adol.html>, on 30 May 2011.
- [7] Z. Bauman. *Liquid Modernity*. Cambridge: Polity, 2004.
- [8] J. Talib. Effects of parents' work conditions on children's school achievement: A study of dual-earner families. *International Review of Business Research Papers*, 5(3), 170-178, 2009.
- [9] N. N. SinghSingh, J. P. Leung, and A. N. Singh. *International perspectives on child and adolescent mental health*. London, UK: Elsevier, 2000.
- [10] [http://www.maithrikochi.org/india\\_suicide\\_statistics.htm](http://www.maithrikochi.org/india_suicide_statistics.htm)
- [11] <http://www.buzzle.com/articles/facts-about-teen-suicide-causes-of-teenage-suicide.html>

# Extreme Right Political Discourse and its Educational Dimensions as they are Projected in the Formal Form of the Greek Extreme Right Political Party of “Chrisi Avgi”

KaleranteEvaggelia

Assistant Professor, University of Macedonia  
[ekalerante@yahoo.gr](mailto:ekalerante@yahoo.gr)

## Abstract

*The present paper is concerned with the extreme right political party of “Chrisi Avgi” and the growing projection of their ideology and standpoints among the educational community, mainly Primary and Secondary education. Their official newspaper has been particularly conducive to the dissemination of their ideology, especially after the two elections of 2012. Besides, one of the major fields of its concern is education. An expanded number of its articles contend that education forms the starting point of building the Greek ideal through the teaching of the appropriate subjects in schools by competent teachers that are able to cultivate this attitude to the students by projecting the Greek civilization. Meanwhile, and given these grounds, special concerns are raised about the disuniting trend among the educational community as well as the country’s national isolation.*

**Keywords:** discourse, education, extreme right, Greek ideal, propaganda

## 1. Introduction

In Greece, since 2008, a time point associated with the commencement of imposing financial measures towards the rationalization of the function of economy with a single-sided view of the curtailment of expenditures and the reduction of shortages, the dynamic presence of the extreme right political party of “ChrisiAvgi” has been simultaneously signaled. The notion of nation and the people’s dynamics against the globalized centers of financial and political control has been projected by the party, having taken advantage of the social disapproval. Within the framework of elevating the nation-state, emphasis is placed on the historic continuation and the notion of Greek-native, through blood bonds, associating the past with the future under cultural and social terms.

At the same time, the notion of migrant as the “other”, a threat against the Greek political system, is elevated. It is well understood that on the basis of this view, an educational system whose ideological base reinforces national composition and the Greek ideal through the juxtaposition with any different culture, by formulating successive fields of racism and antagonism is projected by the extreme right political area.

The educational status seems to be complicated and difficult to understand as there is a schematized reaction against its structure as it has been formulated after the schools merging and suppression along with the reduction of expenditures on education. It should be taken into consideration that some students attending teaching and pedagogical faculties, students and educators have already started to take action and incorporate in the extreme right party the voters percentage of which, as well as the formal or non-formal supporters of its policy, are continuously increasing; therefore, its articulated educational policy, too.

More analytically, the educational standpoints of the extreme right party within the spatiotemporal framework formulating uncertainty and insecurity as a prevailing condition in the Greek society are projected in the present paper. It is also observed how the extreme ideological view about the content of history, the formulation of the Greek awareness along with the gradual deconstruction of notions such as citizen and policy of rights are formed, so that a condition of isolating Greece by rejecting globalized values and humanistic standpoints related to the co-existence of different cultures, the intercultural education and the recognition of the “other” is given meaningfulness.

## 2. Methodology

The present research commenced in 2012 and is still in progress. More specifically, focus was placed on the “Chrisi Avgi” political party’s newspaper

carrying the same title with the party [1]. It is about a weekly circulation also posted on the party's website. The present research is part of the discourse qualitative analysis [2] [3], according to which analysis focuses on articles in the way and form they are presented in the newspaper. In order to study the articles, six sets were generated as the outcome of the articles' systematic study starting from January 2012 until September 2012. Since then, all articles are categorized and analyzed [4] in these six sets so that the ideological framework of the extreme right party as well as its evolutionary course, namely how there is a continuation of their extreme right standpoints and how the struggle for penetration is intensified within the educational premises aiming at the increase of voters – teachers and the simultaneous promotion of the party's principles and standpoints within the educational environment, which will reinforce the teachers' role, especially within a period of their questioning and placing emphasis on authoritative models [5].

Therefore, the six sets that were generated are as follows: a) nation – state, b) people, c) migration issue, d) globalization, e) communism, f) Greek education and g) national fests. After the articles have been studied, they are classified in the corresponding set, that is, the set in which the particular text content corresponds. This is a very hard task as many articles could be classified in more categories. The research will be deemed complete as soon as an evaluation is reached that no more data are due to be added in the generated sets. In other words, the newspaper articles are a reiteration of the same standpoints, even if the facts, namely the timeliness are changing. More specifically, after each article is classified in the corresponding set, which also forms the initial stage, it is scrutinized in terms of: a) the presentation of ideological standpoints, b) the manner of presentation, c) the vocabulary used and the structure of discourse and d) the tension generated.

The coincidence, that is, the temporality within which the news is formulated is taken into account for the present research. For instance, the prior-to-elections period when the content and discourse of the articles are explicitly different or the procedure of legislative regulations such as the recent draft of law related to the anti-racist law or special incidents such as the migrants' beating in the center of Athens by "Chrisi Avgi" members or even educational issues such as criticizing the teacher who encouraged his students to draw the flags of their countries of origin during the preparation for the Greek national fest. The special timeliness is obviously of interest in

terms of its interpretation by the newspaper, the extreme party's instrument, the dimensions of the incident and how a propagandistic discourse is formulated by the party itself ("Today brief guidelines will be given to the nationalist teachers and students about the elimination of the Marxist propaganda in schools. The problem does not lie neither in the students nor in the parents but in the teachers, without offense to the work of teachers. To be specific, there is a distinction between the educators and the Marxist teachers who have conquered education for a long time" [newspaper "Chrisi Avgi" 24/10/2012]). As a result, this is conducive to influencing, directing and rallying the party's members [6].

The method used is the one most effective when it is implemented within a long time period so that the discourse evolution and dynamics is elevated and the texts analysis is meaningful which is able to depict the evolution in a long term in an "ideological game" in which the discourse is formulated in an active political culture. Since reference is made to political texts, the political signified are activated but are rather ambiguous while methodological tools for approach and interpretation are more than necessary without a change of the content and without the addition of data, standpoints or viewpoints that are not elevated by the texts. At this point, an effort is also made regarding the projection of the method-related difficulties so that the framework in which the newspaper articles discourse analysis works is provided.

### 3. Discussion

At the beginning a limited number of articles were published in the extreme right newspaper, in which the discourse was intensely propagandistic and simple; that is, without any difficult expressions or complicated discourse ("Now I am coming to students. Nowadays, Chrisi Avgi is a "trend" at schools. In the past, it used to be KNE [the Communist Youth]. Then it was ONNED [the Right Youth]. Now they are both out of date. We should take advantage of this "trend" like others used to do in the past. Today we are the powerful ones and the youth follow the powerful ones. But above all, we should have certain knowledge in order to argue against the teachers. We should also read history books, not the "formal" ones but the "extracurricular" ones [newspaper "Chrisi Avgi" 24/10/2012]).

It has been estimated that the addressed audience belong to the lower social strata and are found among

the youth population<sup>12</sup> of limited education. Therefore, the texts were rather informative and conducive to tension, at the same time, so that the limited audience of the party is motivated, aiming at followers that would participate mainly in beating migrants or protecting citizens. (There are comments on an article of the democratic newspaper “Ethnos” by the extreme right newspaper of Chrisi Avgi. “Even though supporting Chrisi Avgi is usually confined in swastikas and slogans drawn on walls and desks it is apparent that the young supporters of the organization have “grown” to some extent and their presence is intensified. They sometimes grasp the opportunity to openly express themselves at school events arising, this way, reactions by both teachers and students” [newspaper “Ethnos”, 25/11/2012]. “This is where the essence lays comrades-in-arms. People are annoyed when Nationalists are able to FREELY express themselves. People are thrown into panic because they are PROUD of their ideas. The left “bullying” is fading day by day in the streets, workplaces and schools... and this is only the beginning. Besides, this was a promise made before the elections: The ideological authority of the left will fade away. This is a COMMITMENT [newspaper “Chrisi Avgi”, 28/11/2012]).

The fact that in the first circulations of the newspaper there were announcements about the party’s gatherings along with advertisements about the followers’ clothing as well as about useful objects is not at all accidental. The elections of May and June<sup>13</sup> presented a different view of the extreme right formation. With a growing percentage of voters, an attempt is made to penetrate into the anonymous voters who are not limited, in neither the lower social strata nor people with a limited educational capital. The increased electoral percentage along with the expectation of reinforcing its political power forms the directions towards a change of the party’s propagandistic publication. (There are comments on

---

<sup>12</sup> Quote the special articles about youth issues such as: “Based on researches, a percentage of approximately 80% of the young homeless belong to the productive ages while their educational capital is observed to be better in comparison to former studies. Furthermore, 82,2% are men and 60,7% belong to ages between 41-55, whereas 26,4% are between 26-40 years old. As regards their family status, 33% are divorced and 47,2% have children” (newspaper “Chrisi Avgi” 19/12/2012).

<sup>13</sup> See during the May elections (2012) “Chrisi Avgi” gained a percentage of 6,97% whereas in the June elections (2012) they gained 6,92%. Quote, in the 2009 national elections “Chrisi Avgi” gained a percentage of 0,29%. In the 2010 municipal elections they gained a seat at the Athens Municipality Board having gained a percentage of 5,29%.

the Chrisi Avgi publication about the fear of right rise in Europe as it is formulated by Daily Mail. “For one more time, an English newspaper of the English Lords establishment, the Daily Mail, is extensively concerned with the enormous problem of Chrisi Avgi that has recently been put in the forefront of both the Greek and the international political system. The title of the article is: “The new dark age: Across Europe, free speech and democracy face their biggest threat since the Thirties” [...] Question: Why are the English Lords instruments not concerned with the “threat” of the neo-communist SYRIZA (left party) which is presented as the first political force in the gallops and is the expected next government of the country, but only with Chrisi Avgi? Answer: Because only Chrisi Avgi is a purely anti-systemic party!” [Newspaper “Chrisi Avgi”, 5/12/2012]).

The newspaper pages are increasing while the articles are proofread in terms of correct grammar and syntax. Besides, emphasis is placed on the accurate projection of the party’s ideological standpoints whereas during the former period there was a confined quotation of articles with an ideological fascist content [7] [8] [9] [10].

After the elections, the intension for an ideological conflict is gradually reinforced while a number of professional journalists are apparently incorporated in the party’s journalistic instrument conducive to the use of elaborated discourse, explicit grammatical and syntactical elements while there is completeness in the articles corresponding to the principles of the formal journalistic discourse.

These changes coincide with the reinforcement of the party’s presence, mainly in small towns and the growing number of party organizations. As it has already been realized by another research, the number of teachers and students in the pedagogical and teaching faculties is continuously growing. Moreover, as it has been realized by the interviews to students of the pedagogical and teaching faculties, the extreme right party discourse is deemed attractive, dynamic and responsible especially in association to educational issues.

Therefore, the increased number of education-related articles in the newspaper seems to be justified. In a number of articles addressing teachers and after a careful cross-checking of the pseudonyms used to sign them, it was realized that reference is made to teachers in commission who are responsible for “Chrisi Avgi” issues [11].

On the basis of these observations, the researchers’ standpoint related to the continuation of the research is understood as it becomes obvious that

the newspaper expresses or reflects the party's broader political standpoints which undergo a change or a modification within the fluid, uncertain political and economic situation as it is currently formulated in Greece during a period of economic and moral crisis.

It seems that within an arduous economic environment there is an escalating conflict between the newspaper and the globalized environment of enforcements and controls over the Greek society. The projection of globalization as a threat to the Greek society, under the economic dimension of monitoring and the absent economic drafting, as everything is monitored by external carriers, is commonly projected in all articles [12]. In the last circulations the term "occupation government" is often used as a parallelism between the economic monitoring and the enforcement of Germany during the Second World War. At the same time, the enforcement of a globalized framework of values is elevated in which the "Greek ideal" tends to be absent while a situation in which the intellectual elements are lost, namely the cultural elements, resulting in the Greek's loss of identity, is formulated [13].

The characteristic recurrent attitude "back to the roots" as a request that condenses the ideological standpoint related to the purity of the Greek element is common in all the articles. The same concept is also incorporated in the texts associated with the phenomenon of migration, in which the foreigner is depicted as threat against the Greek element. At this point reference should be made to the existing grading, as by the term "foreigner" special emphasis is placed on the color. Thus, the Pakistanis and Negroes are the primary target group whereas the Albanians, even though outweigh in terms of population being the 50% of the migration population in Greece, do not seem to be the factor of preoccupation for the extreme right formation concentrating mainly to the "Third World Newcomers".

On the basis of the projected ideological framework, the concept of people is given meaningfulness as a unified set in which individuals characterized by the Greek ideal as a national value being the outcome of the contradiction against the globalized values the carriers, of which are not only foreigners but natives of the upper social strata, too, or of the established political classes that "betrayed" and "enslaved" Greece, are incorporated. The ideological framework within which the extreme right party functions is briefly portrayed by the

aforementioned data which also form ideological units which are gradually integrated into the proposals about education.

The necessity to promote a Greek education which is defined as the education concentrating on the Greeks' education through the teaching of the main subjects of Ancient Greek Language<sup>14</sup>, History<sup>15</sup>, Geography, Religion<sup>16</sup> and Citizen's Education is pinpointed by the articles that are exclusively related to education. Reference is made to functional units and it is estimated that they will create those prerequisites to formulate the Greek identity [14].

It is noteworthy at this point that in the up-today collected articles no reference is made to migrant-students who do not seem to form a preoccupation for "Chrisi Avgi". Reference is only made to special occasions, as in the case of national parades in which, as it is foreseen by the Greek law, the excellent students, irrelevant from nationality, should be the heads in the parades by holding the national flag. In these cases, the anti-national legislation is underlined because the national emblem is given to the "foreigners".

Since the migrant student population consists mainly of Albanians, they are deemed assimilated in the educational procedure and society and only when special issues arise, namely the aforementioned national emblem or intercultural educational policies, in the sense of the political presentation of the Albanian culture, is the intercultural education castigated through the sharpest articles as an impediment against the Greek ideal, as an "enforcement" of the globalized centers. (The Chrisi Avgi publication viewpoints about the celebration of the Albanian national holiday are indicative: "In racist Greece" as it is depicted by the Albanian mass media the Albanians are FREE to celebrate their national holiday whereas, at the same time, the residents of Northern-Heperos are PELTED WITH

---

<sup>14</sup> On the contrary, in occupied Greece, the three-party corporation and their previous representatives being the helpers of the most obscene anti-Greek policy, do their best to eliminate the teaching of Ancient Greek language, the language of our predecessors, from schools as well as from our cultural heritage" (28/11/2012).

<sup>15</sup> "The unquestionable continuation of the Greeks. The continuation of the Greeks is therefore taken for granted. Yes! We are the offspring of that huge Nation which generated the Greek Civilization and of that enormous one thousand-year-old Empire that kept the spirit of the Orient away from Europe up to its heroic fall, betrayed even by the West at the Romano's gate in May 1453" (5/12/2012).

<sup>16</sup> The idiosyncratic situation depicted by the subject of Religion through the combination of the ancient religion, namely the faith in the twelve gods, and Christianity is of special interest.

STONES when they are willing to honor the epic of the war in 1940 and its heroes. Students, parents and teachers of the Albanian school in Thessaloniki organized a cultural event, as it was characterized, as an opportunity to celebrate the 100<sup>th</sup> anniversary of the Independence of Albania under the auspices of the migrant Albanian association “Mother Tereza”. Members of the Albanian Consulate of the city as well as various associations of the Albanian community were guests to the particular event” [28/11/2012]). In the case of teaching History, a form of historical narration of events with emphasis on the projection of the Greek ideal and the elevation of the superiority of the Greek race is suggested.

Therefore, emphasis is placed on the vivid, live narrations of battles and actions aiming at the projection of “bravery and masculinity”, the “readiness to fight” in which Greece as a notion will be present in a co-ordinate policy to elevate Greece along with the cancellation of all the globalized standpoints related to a history of civilization; a history that will unify peoples and create those prerequisites for co-existence through the recognition of the “others” [15] [16].

There will be a combination of History and Geography in which time and space will be interrelated so that the unified framework of History is tied to locality as a condition and is attuned to a unified totality. The Citizen’s Education is portrayed as a propagandistic subject in which after a re-arrangement of the ideological standpoints the view about Greece and the “Greek’s rights” will be formed in cognitive modules.

Should a point of formulating Greek education exist in the curriculum and the organization of modules, the other one exists within the educational carriers. At this point, emphasis is placed on teachers whose work is deemed essential to the organization of education towards the Greek education. It is assumed that teachers are trained by the educational system and at this point reference should be made to teachers, mainly of the Primary Education, as they are viewed as the basic factor in formulating the “Greek awareness”.

Pedagogical faculties and teaching faculties, in particular, are deemed to have made a contribution to intercultural education changing the character and content of education because “Greece has been forgotten” [17]. As regards the documentation of events by the newspaper, there is an extended description of events, mostly unnoticed by other publications, such as the cases of teachers that taught another content of history, for instance, having shown

an increased interest in the Greeks of Northern Heperos or that they have implicitly made clear that Greece should vindicate terrains of other countries namely Turkey or Albania, issues that were solved by the international conventions.

It is noteworthy that special references to the celebration of national holidays through the projection of the teachers’ work having elevated issues of the Greek identity through poems or plays is of special interest. Another feature of the latest publications deals with an intensified emphasis and temporarily coincides with the commencement of teaching History at the party’s local organizations. In other words, it is about an organized activity, schematically speaking, of the rewriting of History in which the Greek ideal, the purity of the Greek race are in contrast to the globalized values, the “enforcement, the disdain of the Greek nation and the submission”.

#### 4. Conclusions

The newspaper of the extreme right party of “Chrisi Avgi” is of special research interest as, since 2010, it is a regular issue, rather a popular newspaper citing ideological views and standpoints. Despite criticism or the deconstruction of standpoints which is ventured by the other political parties, the intellectuals, the Mass Media and the other newspapers, the party’s extreme right standpoints are noticed to increase its dynamics and penetrate into traditional left areas by increasing its voters, teachers included. It is noteworthy that in the teachers’ unionist elections “Chrisi Avgi” was represented by unionists – candidates.

Besides, as it has been proved by a former research, there are a growing number of teachers who either vote or like “Chrisi Avgi” such as the young students of the pedagogic and teaching faculties. The newspaper is especially considered with educational issues and there are legislative issues, too, even though it is not addressed to the teacher to inform him about the educational policy. Other texts are separately commented on so that the party’s ideological standpoints are projected in relation to the Greek ideal and the peculiarity of the Greek civilization which is represented as the supreme civilization, distinguishable within a globalized framework and not marginalized within a globalized environment.

It is speculated that globalization has been adopted by the political authority and the left wing intellect, in which communists and Jewish are



included, to cancel the Greek ideal and bringing back the left wing fans' internationalistic views in education. (A newspaper comment about the policy in Ukraine against communism, the "anti-communist draft", is of special interest. "We learnt our lesson from countries of the former east block and not only them, as remarkable steps are taken to eliminate communist signs from the political scene. Oleg Tiagnibock is the head of the nationalistic extreme right party "Freedom" [newspaper "Chrisi Avgi", 7/11/2012]).

It is underlined that the Greek education is absent having been cancelled by the established educational policy which included globalized educational views at the cost of the Greek characteristic values and ideals. As a result, within an intercultural educational environment, Greek students have not acquired those features of the Greek ideal that would make them distinguishable among the "other" lesser peoples. It is noticed that emphasis is placed on issues of "purity" in terms of the white race and on nationality in terms of cultural peculiarity, superiority of the Greece race.

The issue of the exercised criticism on the educational policy should be co-studied with the "Chrisi Avgi" standpoints about the migration policy and the foreign and domestic policy so that common standpoints are elevated projecting a policy against the migrants and, under political terms, a surrealistic view about Greece's objectives related to the extension of its terrain and its establishment as the prevailing power in the Balkans.

The educational content, as it was analyzed, refers to a confining policy about education; that is, emphasis on the national and nationality takes no account of the multicultural reality of societies and the individuals' policy of rights, the students-migrants in this particular case. Placing emphasis on a history of events, where there will be a single-sided elevation of the "Greek writing of History" generates an anti-scientific approach while it does not serve, simultaneously, peace and humanism, two projected values within a cultural framework of communication and harmonization of the people's relations [18].

The intensified projection and obsession of the Greek nation-state is conducive to canceling the cultural works produced by other societies. (In former issues, reference was made to the Marxist plan to impede the ongoing power of Chrisi Avgi at schools and teachers, parents and students were given guidelines related to impeding Marxism and the victory of popular nationalism at schools [newspaper "Chrisi Avgi", 14/11/2012]).

At the same time, a policy of disdaining the "others" is generated conducive to isolating the country. The weakness to vote for the draft against racism seems to be further reinforcing for the extreme right formation's standpoints. (At the moment in Greece a discussion has been taking place about a draft that will penalize racist behaviors. The three-party government is obviously split about this issue as the right wing does not wish to vote such a law. According to their belief, the right wing fans will be polarized and rallied towards the radical right wing). Moreover, it is estimated that the traditional left wing is increasingly inculcated and affected by the "Chrisi Avgi" views resulting in their turning towards more conservative standpoints. The "Chrisi Avgi" views and standpoints seem to appeal to the educational community and this is obvious by the growing number of incidents recorded as "school" incidents and are commented by the newspaper of "Chrisi Avgi".

Another issue of major concern and close observation is the naturalization and legalization of violence. It is deemed the means to enforce "healthy" principles and views to a "political system that does not serve the people". The educational issues are of primary consideration in the newspaper of "Chrisi Avgi" and this is made directly obvious by the growing number of articles. Besides, it is also made indirectly obvious by other articles where it is accentuated the idea that "everything starts from education" and that only the "Greek education" is able to generate other prerequisites. The "national" teachers are distinct from the other teachers who are deemed submitted to the globalized centers, not serving Greece. It is noticed that a disuniting discourse is formulated. In this respect, should one look back in the history of education, the "Chrisi Avgi" standpoints are incorporated in the ideology of the right wing; a fact that distinguished teachers between "nationals" and "communists".

It has been obvious since 1974, a starting point of a democratic, mature period after the dictatorship (1967-1974) that issues of rivalry within the educational community, and broader in society, would be eliminated. Thus, the disuniting discourse comes back due to the articles of "Chrisi Avgi" under political terms. The "Chrisi Avgi" standpoints related to the Greek ideal, the purity of race, the hatred against migrants [19], the Jewish and the communists are attuned to the extreme right parties' policy across Europe [20] [21]. In this respect, taking advantage of the people's anger about the economic situation a populism policy about the protection of the lower

strata is developed. Under conservative terms, a “conservative we” is formulated aiming at a growing dynamics within an unproductive, national, popular discourse [22].

The issue of education is attuned within this more general framework; education is deemed a prerequisite of a national policy conducive to projecting disuniting views, reinforcing contradiction fields [23], generating confining terms in perceiving the “others” through a concentration on the national isolation.

## References

- [1] Kousoumvriss, C. (2004). *Crumpling the myth of ChrisiAvgi*. Athens: Erevos
- [2] Rabon, D. & Chapman, T. (2012). *Investigative Discourse Analysis: Statements, Letters, and Transcripts*. Chicago: Carolina Academic Press
- [3] Titscher, S., Meyer, M., Wodak, R. & Vetter, E. (2000). *Methods of Text and Discourse Analysis*. London: Sage.
- [4] Wodak, R. & Meyer, M. (2009). *Methods of Critical Discourse Analysis*. London: Sage.
- [5] Denoncy, J.P. & Dru, V. (2011.) *Authoritarianism*. Athens: Pedio.
- [6] Hellinas, A. (2012). *Mass media and the extreme right parties in Western Europe. Playing the nationalism card*. Athens: Epikentro.
- [7] Passmore, K. (2002). *Fascism: A Very Short Introduction*. Cambridge: Cambridge University Press.
- [8] Pittas, K. (2011). *The fascist threat and the struggle crack it*. Athens: Marxistiko Vivliopolio.
- [9] Renton, D. (2001). *This Rough Game: Fascism and Anti-Fascism*. United Kingdom: Sutton Publishing.
- [10] Sontag, S. (2010). *Fascism Charm*. Athens: Ypsilon.
- [11] Wolin, R. (2007). *The charm of irrationalism. The romance of intellectuality with fascism: from Nietzsche to postmodernism*. Athens: Polis.
- [12] Edenson, T. (2002). *National Identity, Popular Culture and Everyday Life*. Oxford: Cowley
- [13] Buelens, F. (2000). *Globalisation and the Nation-State*. U.K: Edward Elgar Pub.
- [14] Wodak, R., Cillia, R., Reisigl, M. & Liebhart, K. (2009). *The Discursive Construction of National Identity*. Edinburgh: University Press.
- [15] Burgess, H.W. (2001). *Models of Religious Education: Theory And Practice in Historical And Contemporary Perspective*. United States: QualityBooks
- [16] Moran, G. (1989). *Religious Education As a Second Language*. USA: Religious Education Pr.
- [17] Kalerante, E. (2013). *The Youngsters' Participation in Extreme Right Political Parties in Greece: the case of students – supporters of “ChrisiAvgi” in American Journal of Educational Research*. (submitted)
- [18] Sunic, T., Benoist, A. & Gottfried, P. (2011). *Against Democracy and Equality: The European New Right*. California: Noontide
- [19] May, S., Modood, T. & Squires, J. (2004). *Ethnicity, Nationalism, and Minority Rights*. Cambridge: Cambridge University Press.
- [20] Milza, P. (2004). *The blackshirts of Europe. The European extreme right parties from 1945 until today*. Athens: Scripta.
- [21] Mudde, C. (2007). *Populist Extreme Right Parties in Europe*. Cambridge: Cambridge University Press.
- [22] Johnson, D. & Potok, M. (2012). *Right-Wing Resurgence: How a Domestic Terrorist Threat is Being Ignored*. Lanham: Rowman & Littlefield Publishers.
- [23] Norris, P. (2005). *Extreme Right: Voters and Parties in the Electoral Market*. Cambridge: Cambridge University Press.

# Games Playing Effects on Elementary Students in Bangkok

Sumalee Chanchalor  
Faculty of Industrial Education,  
King Mongkut's University of Technology Thonburi, Bangkok, Thailand  
Teparat Suthiroeng  
Sommapa School, Ramintra Bangapi Bangkok, Thailand

[isumalor@kmutt.ac.th](mailto:isumalor@kmutt.ac.th)

## Abstract

*Many children are game fever. It is questioned how it effects players. This paper determined on effects of online gaming toward emotional quotient of the primary school students. Tools were questionnaire, online game, test of emotional quotient (EQ). Group of game addict and non game addict were asked to participate the experiment of playing game for 400 minutes. Their EQ. were tested in period of 200 min, 400 min. The findings revealed some impacts of playing online game, especially in group of game addict. The effects of playing game for addict and non addict seem to be differently. It found negative correlation significance in group of game addict in some issues, however, for non addict, there were only few items.*

## 1. Introduction.

Online game have become one of the favorite activities of children [1]. It is easy to approach, since internet cafes specializing in online game are every where which has been speculated which might promoted addictive tendencies. The increasing exposure of children and adolescents to electronic media is in Thailand and all over the world. More than one million of Thai children and teenagers addict to on line game. A study of Jaruratanasirikul, et al.[2] about Thai children and adolescents in southern Thailand found that Thai children and adolescents played electronic games on an average three hours a week.

Viriyavejakul [3] surveyed on recreational gaming behavior of undergraduate students in Thailand revealed that students played computer games average 7-15 times a month, 1-2 hours each time. Most often, they played at home, whereas 31% of them played games in game shops for relaxation.

Games are designed so that the content and form of losing and winning make it difficult to stop playing[4]. Several Thai children spend time in front of the computer screen several hours each day without doing other activities [2]. Some studies showed a negative association between amount of video game playing and school performance for children[5]. Hasithavech[6] mentioned impact on all society and on quality of life such as negative correlation between recreational video game playing and grades[7]. Students who spend more time playing video game or spend more money on video games had poorer grade[8].

In Thailand, youth addiction to video game playing has been recognized by government as a problem. The government is considering imposing a curfew for online game shops. Gaming is not only a problem in Thailand, it has been recognized as problematic around the world[9],[10],[11]. Thailand is a very good context in which to study the impact of gaming especially in group of elementary school students who are easy to absorb its effects.

Owe to the information we have, it didn't cover effects of playing game as the whole aspects such as EQ. This study will provide the fulfill information which cover many aspects of life. This study will provide the information about effects on playing game in specifics group of addict and non addict group at elementary level. The information will point out the ways for parents to manage proper situation for their children which will find out how children play online game The experiment study is going to find out how games show the impacts on EQ. focus in cases of additive and non additive players, The finding will provide the information which can set for the youth learning.

## 2. Objectives.

1) to identify the frequency and length of time playing games

2) to study the correlation between behaviors and students' EQ.

3) to compare the effects of playing online games on elementary school students between addict and non addict.

### 3. Methodology.

#### 3.1 Participants

Participants for the survey was 400 elementary school students in Bangkok. Then sixty of purposive students were divided into addict and non addict game players. They were asked to participate in the experiment.

#### 3.2 Instruments

1.) A questionnaire was developed to ask about the behavior and impacts of playing games online such as the frequency to play, period of playing, experience of playing etc.

2.) E.Q. test: The test was developed and set criterion for norm of people by Psychology Institutes of Thailand. It includes three main aspects (nine issues) on: good persons (three issues), smart persons (three issues) and happy persons (three issues).

#### 3.3 Procedures

For surveys: Four hundred elementary school students in Bangkok were asked about the behavior of playing games.

For the experiment, 60 purposive participants in elementary school were divided into group of game addicts and of non game addict by period of playing and their behaviors of eager to play game. Both groups of participants were asked to do E.Q. test before the experiment, during the experiment (200 min.) and after the whole experiment (400 min) consequently to study how playing game impact EQ.

### 4. Result.

It was found that boys seem to be more game addict than girls. Game addict played more often and longer than non game addict. They obtained more experience and spend more money on game playing as shows in Table 1.

**Table 1.** Students' behavior of playing online games.

Issues	Percent	
	Addict	non addict
Gender		
Boy	73.3	40.0
Girl	26.3	60.0
Period of playing		
< 1 hr.	0.0	46.7
1- <2hrs.	20.0	40.0
2-<3 hrs.	50.0	10.0
3-4 hrs.	3.3	3.3
>4 hrs.	26.7	0.0
Frequent a week		
5-7 days	60.0	0.0
3-4 days	23.3	13.3
2 days	13.3	23.3
1 day	3.3	63.3
Experience		
more than 3 years	43.3	0.0
2-3 years	40.0	20.0
<= 1 year	6.7	50.0
no experience	0.0	16.7
Place to play		
home	76.7	73.3
Other place	23.3	26.7
Expenses each playing		
<50 bath	20.0	86.7
50-100 bath	13.3	13.3
>100 bath	66.6	0.0

The study on correlation between EQ. score and their behaviors, which were frequency of playing, experience of playing, average period of playing and expenses for playing game. The study in group of non addict and group of addict as in were in Table 2 and Table 3 respectively.

**Table 2.** The correlation between average EQ. score and their behavior for group of nonaddict.

Behavior EQ.	Freq (X <sub>1</sub> )	Experience (X <sub>2</sub> )	Period (X <sub>3</sub> )	Exp (X <sub>5</sub> )
1. Emotional control (Y1)	-.02	.04	.03	-.01
2. Sympathy (Y2)	.14	.14	.1	-.01
3. Responsibility (Y3)	.19	.19	.1	-.17
4. Self Motivation (Y4)	.11	.09	.10	.0
5. Decision making/problem solving (Y5)	.30	.19	.08	.16
6. Good Relationship with others (Y6)	.26	.20	.13	.23
7. Pride in themselves (Y7)	.20	.08	.13	.01
8. Satisfaction in life (Y8)	.19	.09	.10	.39*
9. Peace mind (Y9)	.05	.15	.14	.44*

\*P < .05

From Table 2, it was found that there were negative correlation significance in group of non addict at .05, only the issues between expenses and satisfaction in life, peace mind. The correlation of the other pair issues were no significant differently.

**Table 3.** The correlation between EQ. and behavior of game addict group.

Behavior EQ.	Freq.	Experience	Period	Exp.
1. Emotional control (Y1)	-.54**	-.58**	-.55**	-.17
2. Sympathy (Y2)	.37*	.45*	.52**	.13
3. Responsibility (Y3)	-.56**	-.35	.40*	.09
4. Self Motivation	-.52**	.42*	.38*	.12

(Y4)				
5. Decision making and problem solving (Y5)	-.57**	-.47**	-.39*	.17
6. Good Relation (Y6)	.14	.14	.17	.15
7. Pride in themselves (Y7)	.18	-.30	-.12	.06
8. Satisfaction in life (Y8)	.21	-.16	-.26	.19
9. Peace mind (Y9)	-.54**	-.37*	-.51**	.13

\* p < .05, \*\* p < .01

From Table 3, it was found negative correlation significantly in group of non game addict at .01 on emotional control and frequency, experience, period of playing; on sympathy and period of playing; on responsibility and frequency; on self motivation and frequency; on decision making and frequency, experience; on peace mind and frequency, period.

The negative correlation significantly at .05 on sympathy and frequency, experience; on responsibility and period; on self motivation and experience, period; on decision making and period; on peace mind and experience. The correlation of others issues have no statistical significant

To find out how playing games online impact the elementary school students' E.Q., the experiment was carried on, sixty participants of survey group was divided into two groups, addict and non addict by their behavior of playing game. They were asked to play an exactly game, each time for forty minutes until 400 minutes. It was found that before the experiment, all participants' score of EQ. were over the criterion. However, after playing excited game proposed to them for 200 minutes, the average EQ. scores on Sympathy and Responsibility of participants in addict group become lower than criteria. After playing the excited game for 400 minutes, the average EQ. scores on eight of nine issues in addict group became lower than criterion; the average scores on six of nine issues of non addict group became lower than criterion. Table 4 shows the results.

**Table 4.** Descriptive statistics of E.Q. scores of elementary school children.

Issue	Before		200 min.		400 min.	
	x, s	d	x, s	d	x, s	d
(Y1)						
ad dict	7.0	.2	.16	.9	.15	.8
non	7.4	.8	.16	.3	.15	.9
(Y2)						
ad dict	7.0	.9	.14	.1	.12	.2
non	8.0	.6	.16	.6	.14	.1
(Y3)						
addict	7.7	.5	.14	.4	.13	.4
non	9.2	.2	.18	.0	.15	.8
(Y4)						
ad dict	6.8	.9	.16	.5	.14	.1
non	7.1	.5	.16	.1	.15	.1
(Y5)						
ad dict	4.7	.7	.14	.2	.12	.1
non	5.0	.81	.14	.7	.14	.2
(Y6)						
ad dict	6.4	.41	.15	.1	.13	.7
non	5.6	.07	.15	.3	.14	.3
(Y7)						
ad dict	0.5	.7	.10	.4	.2	.5
non	0.6	.9	.10	.3	.2	.5
(Y8)						
ad dict	7.4	.3	.16	.3	.13	.3

n	1	2	17	3	13	3
	7.7	.8	.4	.0	.5*	.0
(Y8)						
ad dict	7.1	.6	.16	.4	.13	.9
Non	7.7	.9	.16	.8	.14	.8

\*Lower than criterion

## 5. Conclusion and Discussion

The study of students' playing game found that all game addict participants played more than 1 hour each time. Most of them played more than 5 days a week. Eighty three percent played over 2 years whereas non game addict group play less in every issues. As Viriyavejakul [3] revealed, undergraduate students in Thailand played games average 7-15 times a month, 1-2 hours each time. Whereas Cummings and Vandewater [12] reported the average time that gamers played was a hour on the weekday and an hour and a half on the weekend.

After 200 min experiment of playing excited game, it found that EQ. score of elementary students seem to be some effects to group of game addict such as sympathy, responsibility. The more time they played, the lower score than criterion they obtained continuously. After the children played for 400 minutes, their average EQ. score of addict group was lower than criterion in almost every issues. For group of non addict, their EQ. score was lower but less than of addict group.

Time and frequency of playing might have impacted on the EQ. score. Gentile and Gentile [13] reported the effect of playing violent video games: The more frequently across time should be, the more likely to learn aggressive cognitions and behaviors than those who play the same types of games but less frequently. Meanwhile Barlett et al. [14] confirmed that some non-violent video game related to some specific positive learning. As Viiyavejakul [3] found that game help children to relax from stress. Whereas a review by Barlett et al. [14] revealed that violent game exposure is causally related to a host of negative and a few positive outcome. Games were designed to entertain and excite which is the positive aspect of playing games. This finding might be the evident to support that we should concern to type of the games to

play, control suitable time to spend on game. Thus playing game will provide less effects as in non addict group. If parents and teachers manage the program and choose suitable game well, it will be beneficial to

children. It means that parents made good relationship with their children so that they will be able to tell their children effectively.

When we study the background of playing such as period of playing and frequency of playing each, there was the negative correlation, especially in group of game addict. This study limited to only one exactly game. In the future, we should study more various types of game and its level of violence. Children are favorite of game which we can't avoid thus teacher or parent should concern to period of playing and frequency of playing. Games might not be harmful to children if they know to manage time to play, and to have self-discipline. Thus playing games may cause benefits in some condition.

## 6. References

- [1.] Gentile, D. A., Lynch, P. J., Linder, J. R., & Walsh, D. A. (2004), "The effects of violent video game habits on adolescent hostility, aggressive behaviors, and school performance", *Journal of Adolescence*, 27, pp.5-22.
- [2.] Jaruratanasirikul, S., Wongwaitawewong, K., & Sangsupawanich, P. (2009), *Cyber Psychology & Behavior*, 12(5), 509-512. doi:10.1089/cpb.2009.0035.
- [3.] Viriyavejakul, C. (2008), "Recreational Gaming Behavior of Undergraduate Students in Thailand ", in K. McFerrin et al. ( Eds.). *Proceeding of Society for Information Technology & Teacher Education International Conference 2008 AACE* pp. 4948-4955.
- [4.] Laird, J. (2005), "Principles of Game Design", Retrieved from [www.emunix.emich.edu/Game Programming/lecture note](http://www.emunix.emich.edu/GameProgramming/lecture%20note).
- [5.] van Schie, E. G., Williams, R., & Wiegman, O. (1997), "Children and videogames : Leisure activities, aggression, social integration, and school performance", *Journal of Applied Social Psychology*, 27, pp. 1175-1194.
- [6.] Hasithavech, N. (2005), "The result of arranging group activity for treating children addict game as per theory of adapting intellectual behavior on the basic of Maxtrix Program's knowledge", *Research report*, Teenager and Child Psychology Institute of Ratchanakarin. Psychology Department.
- [7.] Gentile, D. A., & Anderson, C. A. (2003), "Violent video games:The newest media violence hazard", Retrieved from D.A. Gentile Media violence and children. Westport.CT:praeger publishing: <http://asia.cnet.com/blogs/thai-ministry-of-culture-wages-war-on-gaming-62116076.htm>.
- [8.] Anderson, & Dill. (2000), " Video game players and aggressive thoughts, feelings, and behavior in the laboratory and life ", *Journal of Personality and Social Psychology*, 78, 772-790.
- [9.] Sherry, J. (2001), "The effects of violeont video games on aggression: A meta-analysis", *Human Communication Research*, 27, 409-431.
- [10.] Anderson, C. A., & Bushman, B. J. (2001), "Effects of violent video games on aggressive behavior, aggressive cognition, aggressive affect, physiological arousal, and prosocial behavior: A meta-analytic", review of the scientific literature. *Psychological Science*, 12, 353-359.
- [11.] Anderson, C. (2004), " An update on the effects of playing violent video games", *Journal of Adolescence*, 27, 113-122.
- [12.] Cummings, H. M., & Vandewater, E. A. (2007), " *Relation of Adolescent Video Game Play to Time Spent in Other Activities* ", Retrieved from American Medical Association: <http://www.ncbi.nlm.nih.gov/pubmed/>
- [13.]Gentile, D. A. & Gentile J. R. (2007), " Violent Video Games as Exemplary Teachers: A conceptual Analysis", *Journal of Youth and Adolescence*. Springer Science +Business Media.
- [14.] Barlett C.P.,Anderson C.A. and Swing E.L.(2009.), "Video Game Effects-Confirmed, Suspected ", and Speculative", *SAGE Journal*,3, 377-403.

## A Sociological Survey about Impact of Internet on Socio-Cultural Life of High School Students

Dr. Masoumeh Motlaq

PhD in sociology, Assistant professor, Islamic Azad University, Arak Branch, Iran

[Masoum\\_motlaq@yahoo.com](mailto:Masoum_motlaq@yahoo.com)

### Abstract

*This paper examines the impact of internet on socio-cultural life of students. The goal of this research is to study the effect of internet as an important technology on the high school students as great users. This is a survey-method research based on a questionnaire. For this purpose, 384 high school students (boys) of the study area have been selected by random sampling. Having gathered the data, SPSS software is used for data processing according to Pearson Test.*

*The findings are based on the theoretical approach in information society and sociological theory and finally the findings support the impacts of internet on socio-cultural life like communication, services and education in the case study (boys' high schools in Arak city -Iran).since the results are conducted upon hypotheses, variable indicated that there is a meaningful relationship between internet and socio-cultural life of students. It shows that information age can influence on all the users especially students which need more awareness and surveillance.*

### 1. Introduction

Information and communication technologies perform a vital part in our lives recently as if the most action and interaction of people rest upon Information and communication technology ,for example internet as the famous index of ICT plays a significant role in all the area of our lives . As Castells stated, this age is labeled as the information age "we are passing from the industrial age into the information age"[1]. The internet not only connects

the people together but also shares a lot of information, software, gadget and entertainment among people around the world.

The Information Age formed by capitalizing on the computer microminiaturization advances, with a transition spanning from the advent of the personal computer in the late 1970s, to the Internet's reaching a critical mass in the early 1990s, and the adoption of such technology by the public in the two decades after 1990 bringing about a fast evolution of technology in daily life, as well as of educational life style, the Information Age has allowed rapid global communications and networking to shape modern society [2].

The generally speaking, the development of an open source operating system by Torvalds (1996) spurred the development of open content that users could access free of charge, especially for educational purposes. Some excellent examples are the Open Educational Resources (OER) Project which has become the OER Commons (2008) and Curriki (2008) both of which provide educational content for schools. However, the most accessed content service in education on the WWW is Wikipedia (2008) which is a good place to begin searching a topic, although users need the skills to determine the currency, relevancy and accuracy of items. These three projects are examples of collective intelligence being utilized to develop large collections of information for public global access. Many open projects have been enhanced by the development by Laurence Lessig from Stanford University of a public access, copyright-free regime for trusted internet users called the Creative Commons [3].

Obviously young people, particularly Students are one of the great users of this technology. So the reaction of teen group to this new situation and digital life is an important item.

### 2. Theoretical framework

W. J. Mitchell point out the impact of information and communication technology on the

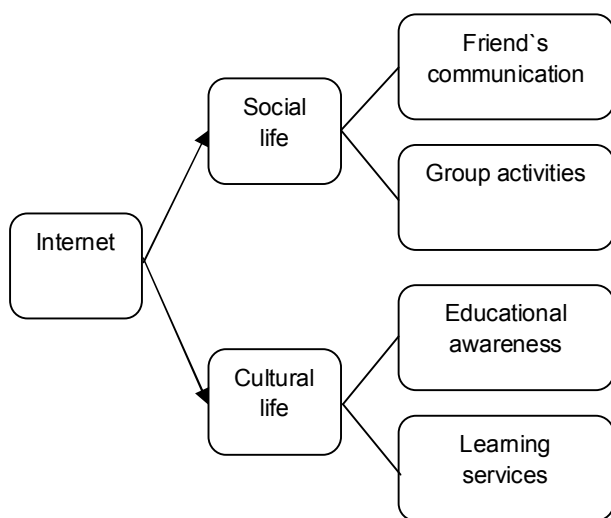


society and its role in the digital life for the future and explain the importance of the physical representation of digital information in the creative learning process, and how information technology can act as a powerful amplifier of creativity[4].

The third wave by Toffler state that new pattern of life is happened by information age .This thought impacts all the spheres which make up a civilization phase: technology, social patterns, information patterns," power" patterns. Finally, children, in the electronic cottage, may return to the work force, both participating in the family's programs, expanding their education, working with their computers and doing their homework as a student. "What is happening now is nothing less than a global revolution, a quantum jump in history" [5].

Castells explain about the changing role of space, place, and distance as an influential thinker of a network society [6]. Castells `s theory of the network society provides a rather wide framework to connect to an integrated analysis and very diverse phenomena. Two emergent social forms of time and space characterize the network society while coexisting with prior forms. There are the space of flows and timeless time [7].

### 2.1. Model and hypotheses



**Figure1. Research theoretical model**

Hypotheses are classified as follows:

There is a significant relationship between internet and social life of students.

Internet impacts on strengthening of friends' communication among students.

Internet impacts on improvement of group activities among students.

There is a significant relationship between internet and cultural life of students.

Internet impacts on educational awareness among students.

Internet impacts on easy access to learning services among students.

### 3. Method

This is a survey –method research based on questionnaires. The study area is in the central part of Iran, Arak city in Markazi province. For this purpose, 348 students of the study area have been examined based on Cochran `s formula who was selected through random sampling. Having gathered the data, SPSS software is used for data processing according to Pearson.

### 4. Results

Here the research hypotheses are tested based on Pearson correlation as follows:

**Table1. The correlation between internet and strengthening of friends' communication**

correlation	N	Pearso	sig
internet	384	0.183	0.002
strengthening of friends' communication	384		

A significant correlation was observed between the usage of internet and strengthening of friends' communication among students. (R=0.183%, sig=0.002<0.05)

**Table2. The correlation between internet and improvement of group activities**

correlation	N o.	Pearson r	sig
internet	3 84	0.136	0.017
improvement of group activities	3 84		

A significant correlation was observed between the usage of internet and improvement of group activities among students. (R=0.136%, sig=0.017<0.05)

**Table3. The correlation between internet and educational awareness**

correlation	N o.	Pearson r	sig
internet	3 84	0.128	0.000
Educational awareness	3 84		

A significant correlation was observed between the usage of internet and educational awareness among students. (R=0.128%, sig=0.000<0.05)

**Table4. The correlation between internet and access to learning services**

correlation	N o.	Pearson r	sig
internet	3 84	0.155	0.004
Access to learning services	3 84		

A significant correlation was observed between the usage of internet and access to learning services among students. (R=0.155%, sig=0.004<0.05)

## 5. Discussion and Conclusion

Nowadays, way of life for someone is influenced by information communication technology, especially for younger and students that their environment is manipulated by these new technologies, particularly internet. "As we move into the 21st century, schools have to enculturate students to be lifelong learners. Students need to learn how to seek out new information, think critically and show initiative to meet up with the challenges of the fast-changing world. Research studies of Information and Communication Technologies (ICT) in schools have established that ICT facilitates the enculturation processes of lifelong learning (Sivin-Kachala, 1998; Wenglinsky, 1998; Mann, Shakeshaft, Becker and Kottkamp, 1999). However, many of these studies lack detailed investigation of what actually takes place in the ICT learning environment and its socio cultural context"[8]. As technology advances, it is used to benefit to all the people but as the internet extend, it is basically at students' services so it can be useful for students of all ages and different levels in the learning process. For example, modern education recognizes each child as an individual and caters for learning theories that empower the child to play an important role in their own education [9]. So as the results and the related theories and research shows internet impacts on socio-cultural life of students it means that friends' communication is strengthening due to social networks, chat rooms and virtual reading room in different area which interact teenagers and peers. Also it impacts on improvement of group activities among students it can be voluntary group e.g. for child labor, disaster children or even any important event not only in their country but also around the world, the athletics or artistic group, fan club are some of these positives activities. Internet impacts on educational awareness and effects on easy access to learning services among students by the presence of wireless internet, web and online educational software, all the students are at the same starting level and the rest of the progress based on the potentialities and basic facilities; students can buy language learning software and the other learning packages, chat with their classmate in all the world, check the exercises on the different websites, study about different fields of knowledge and also about related topic. Students can compare themselves with

the other students in challenging tests in their classrooms and they can use virtual lesson and learning period in all the seasons. Students can use online enrollment system, In addition, the internet makes it possible for workers in developing countries to provide in-person services and compete directly with their counterparts in other nations. Internet is a potentially powerful instrument for developing educational opportunities, both formal and non-formal, also increasing access to and improving the relevance and quality of education. It shows that information age has great board and students are able to gain access to online dictionaries, encyclopedias and all sorts of resource materials, so it can influence on all the users especially students which need more awareness and surveillance. The total, generally organized way of life, including values, norms, institutions, and artifacts and leisure time are influenced by information age too and need more investigation in different area, each one is considered as a nice subject for young researchers. "Without denying that the internet provides new possibilities for information, communication, commerce, entertainment, and social interaction, critics tend to argue that the quality of these activities is harmed when they are performed over the Internet. So there is a comparative harm: compared to traditional ways of performing these activities, the Internet offers us an inferior or less beneficial way of performing them .In addition, critics perceive a number of other negative consequences of Internet use, that concern human development, human experience and social organization"[10]. Certainly, students should learn how to stay safe on the internet and face with it as a helpful instrument.

## 6. References

- [1] Castells, M. "Materials for an Exploratory Theory of the Network Society" British Journal of Sociology, Volume 51, Tavistock Publications, 2000.
- [1] Castells, M. "The Rise of the Network Society: Economy, Society and culture, v1 2000.
- [2] Kluver, Randy. "[Globalization, Informatization, and Intercultural Communication](#)". [United Nations Public Administration Network](#). Retrieved 18 April 2013.
- [3]White, Gerry ICT Trends in Education at: [http://research.acer.edu.au/digital\\_learning](http://research.acer.edu.au/digital_learning) Part of the Educational Assessment, Evaluation, and Research Commons, 2008, p9.
- [4] Mitchell, W.J city of bits: Space, place and Infobahn .The MIT press, Cambridge, MA. 1980
- [5]Toffler, Alvin, Previews & Premises: An Interview with the Author of Future Shock and The Third Wave, Black Rose books, 1987
- [6]Navabakhsh, M. and Motlaq, M. Effects of urban information and communication technology on sustainable development, Journal of food, agriculture and environment vol.7 (3&4): 2009, 891-897
- [7]Navarria, G, Castells`s theory of the network society available at:<http://www.Johnkeane.net> 2007.
- [8] Fitzpatrick, Miriam Creating a living educational theory through ICT; enabling enhanced learning through multimedia authoring in an early childhood setting. Dublin City University, School of Education Studies, Supervisor Ryan, M. 2004
- [9]Lim, Cher Ping A theoretical framework for the study of ICT in schools: a proposal, *British Journal of Educational Technology* Vol.33 No 4 2002, 411–421
- [10] Brey, Philip Evaluating the Social and Cultural Implications of the Internet Computers and Society, 36 (3). 2006, pp. 41-48. ISSN 0095-2737

# A Framework of Network Learning Environment toward Constructivist to Enhance Problem-Solving Process on the Topic “Hardware Using” for MathayomSuksa 1 Students

SakesunYampinij, Suwaree boonnak  
Faculty of Industrial Education and Technology, King Mongkut's University  
of Technology Thonburi<sup>1,2</sup>  
[Saksun.yam@kmutt.ac.th](mailto:Saksun.yam@kmutt.ac.th), [suwaree\\_fon@hotmail.com](mailto:suwaree_fon@hotmail.com)

## Abstract

*This research aimed to develop the framework of network learning environment toward constructivist to enhance problem-solving process on the topic “Hardware Using” for MathayomSuksa 1 students. The samples were 3 instructional designers sampled from purposive sampling. Research instrument was congruence evaluation form of instructional design. The development of framework found that there were 7 components; 1) Authentic problem situation: this was designed for activating the learning process, 2) learning tasks: this was designed toward problem-solving process to enhance the students’ practice for learning through the problem-solving process, 3) learning resource: this was designed to support the inquiring system or searching information through the problem-solving process. 4) problem-solving training center: this was designed to practice problem-solving skill using the case study of problem-solving situation, 5) scaffoldings: this was designed to help the students by problem-solving suggestion, 6) communication tools: this was designed on the principle of constructivism to support the students in constructing knowledge using interaction among the learners and the experts and 7) expert’s guidance: this was designed to enhance the students in access knowledge and experience from the expert using chatting, asking questions in any channel of communication. There was also a specific discussion about the impact of learning environment design and the suggestion for the further research.*

## 1. Introduction

Educational management takes important roles in developing human on surfing and applying information technology. Educational management

nowadays shifts up the paradigm to ‘Student Centered Learning’. The students learned via interaction with any learning resources and leads to knowledge construction. [1] Banna School, Kapor District, Ranong, provides kindergarten, elementary, and high school level of study under the control of Basic Education Commission has a policy to enhance the learners’ knowledge construction and problem solving process using information technology and internet network. In addition, the policy also develop the learners’ quality in Matayom Suksa 1-3 students to construct the knowledge using information technology and gain skill for problem-solving process in real life by the age.[2]

The study of learners’ problem founded that the students of Matayom Suksa 1 gained lower than standard achievement. The students could not apply knowledge for problem –solving process in real life. Part of the problem might caused by the learning management that fixed to lecturing and used only the texts for learning resource. The students could not potentially use skills. The students could also not transfer the knowledge or skills to real life situation. The varieties of learning resources were not provided to the students. So the teachers could not stimulate the students to pay attention in lesson. At last, the students were not eager to learn and many of students could not pass the evaluation.

Learning environment toward Constructivism believe that the learning process is the cognitive process in human. Learning management should be the stimulation of cognitive restructuring. The problem situation was used to stimulate the students to get cognitive conflict or disequilibrium. The learning of problem - solving process is the connection of prior knowledge and new knowledge in real life, so the cognitive restructuring condition is occurred and finally the knowledge was constructed. [3] The students’ role change from the knowledge

receiver to the knowledge surfer. The students will have chances to potentially use the thinking skills. In addition, learning management on internet network system also enhance the students to access the varieties of learning resources and gain the experts' experience. The knowledge sharing via the social network and many kinds of online media such as website, web blog, and YouTube video that make the students connect the theoretical knowledge to real life problem – solving process.

As mentioned, the researcher realized to solve the problem of the learners. So the researcher designed the learning environment under the theory of constructivist. This learning environment is used as the instructional media for knowledge construction via problem – solving process and to enhance the skill of problem – solving. This learning environment applied technology and integrated with constructivism concept to create the learning environment for problem – solving skill of the students. The students can construct the knowledge and the teachers gain the modern instructional media to stimulate and gain attention for the students via internet network. The students can also connect their knowledge with varieties of learning resources to develop effective learning management.

## 2. Objectives

The first phase of research aimed to

1.Design the learning environment using constructivism concept via internet network to enhance problem – solving skill for Mathayom Suksa 1 students on the topic “Hardware Selecting”

2.Study the quality of learning environment designed for enhancing problem – solving skill for Mathayom Suksa 1 students on the topic “Hardware Selecting”

## 3. Expecting advantage

This first phase of the design and development research under the framework of Richy, R.C. and Klein[4] focused on learning environment design using constructivism concept and checked the quality of the design. This first phase of research will lead to development of learning environment on the second phase. The expecting advantage from this research is to enhance knowledge construction of the students and give the chance to surf and access the knowledge in varieties of learning resources. The students also gain the skill of problem – solving process and

connect the knowledge to the principle for problem – solving in the real life.

## 4. Target

The target groups for this research were the 6 experts who check the quality of the design of learning environment using constructivism concept via internet network to enhance problem – solving skill of the students. There were 3 experts for checking the content and 3 experts for instructional media.

## 5. Research Variables

Independent variable: the design the learning environment using constructivism concept via internet network to enhance problem – solving skill for Mathayom Suksa 1 students on the topic “Hardware Selecting”

Dependent Variable: the quality of learning environment design using constructivism concept via internet network to enhance problem – solving skill for Mathayom Suksa 1 students on the topic “Hardware Selecting”

## 6. Research Instrument

The research instrument of the research was an evaluation form of learning environment design. This form has three dimensions of evaluation; the quality of content, the quality of learning environment design and the quality of evaluation design.

## 7. Data Collecting

The data collection of the quality of the learning environment design by the experts were collected from the evaluation form using the index of congruence (IOC) via the opinion of the experts in 3 dimensions; the quality of content, the quality of learning environment design and the quality of evaluation design.

## 8. Data Analysis

The data of experts' opinion on the quality of learning environment design was analyzed by the analytical descriptive and conclusion of the data interpretation from the evaluation using index of congruence of the evaluation form of quality. The analysis of 3 dimensions was the quality of content, the quality of learning environment design and the quality of evaluation design.

## 9. Research Findings

### 9.1 The design of learning environment using constructivism concept via internet network to enhance problem – solving skill for MathayomSuksa 1 students has 7 components:

**1. Authentic Problem Situation:** the problem situation was designed to stimulate activated learning process via the real life situation problem. This component is designed to enhance the problem – solving ability. The initiate step is to stimulate the students with problem base situation. The problem situation uses problem-base learning technique to stimulate the students with problem to gain disequilibrium. The students try to do accommodation and adapt themselves for the state of equilibrium or learning. The researcher uses this principle to design the problem situation of real life and finding the answer or the way of problem – solving process. The content of “Selecting hardware” was designed for the students.

**2. Learning tasks:** the learning task was designed to enhance learning process via the authentic problem – solving situation. The 9 learning tasks will be consequence: 1) the students will be grouped for 3-5 members of different ability, 2) the teacher and students set the rules of learning and prohibition, 3) the teacher and students set the criterion of grading and reinforcement, 4) each of students reads the problem situation, 5) each group of students identify the problems, 6) the students think together to surf knowledge from varieties of learning resources, 7) each students investigates the answer for the problem situation as in step 6, 8) the answers are synopsisized for the answer of the group, and 10) the teacher and students discussion the answers of each group to summarize as the answer of the class.

**3. Learning resources:** This component was designed to enhance the process of learning investigation. The knowledge investigation via the problem – solving process uses information technology on the topic “Selecting hardware”. The information technology is necessary for problem – solving process. The information technology used are web site, video, case study via web site.

**4. Problem-solving training center:** this center was designed to enhance problem – solving via the case study. Any case study of problem – solving process will help the students the solve problem until the students gain skillfully.

**5. Scaffoldings:** the scaffoldings was designed for the under standard students or students who cannot solve the problem. Those of students are under the zone of proximal development beyond Vygotsky. [4] The under zone of proximal development students have to suggest or give advice to solve the problem. The design uses strategies such a scaffolding of concept for problem – solving, the content about hardware, and the scaffolding of learning process and problem-solving.

**6. Communication tools:** the communication tools were designed on OLEs model of Hannafin [5] by applying social constructivist as a tool for enhancing the knowledge construction via the interaction between the learners, teacher and the experts. The communication tools of social network help the teacher for reflecting the idea and give the advices, support the students in connecting the prior knowledge to solve the problems, for sharing knowledge, experiences among learners, and teacher, and also used for transferring the lesson learned in the process of problem – solving. The communication tools of social network were such as Facebook, Skype.

**7. Expert’s guidance:** This was designed to enhance learners to access the knowledge and experts’ experiences. The students can ask any questions via any channel of communication such as chatting, asking questions. The communication channel can help the students who lack of experience. The experts’ guidance in the field of knowledge such a hardware selection, the students will contact, ask for information via the social network tools such as Facebook, E-mail.

### 9.2. The quality of learning environment design using constructivism concept via internet network to enhance problem – solving skill:

The finding was that the quality of content, the quality of learning environment design and the quality of evaluation design has wholly related to the principle of basic framework to design this learning environment. The finding of evaluation showed that the learning environment toward constructivism to enhance problem-solving process on the topic “Hardware Using” for MathayomSuksa 1 Students harmonized to the objectives of the design. This showed the confirmation of using in the classroom.

learners' readiness in using technology, the readiness of basic structure of learning management.

## 10. Research Discussion

The design of learning environment using constructivism concept via internet network to enhance problem – solving skill, the experts' opinion approved the quality of the design of learning environment. The quality evaluation of content, learning environment design and evaluation design revealed that all dimension evaluated had quality and harmonized with the principle or framework used in the design. The learning environment can response the learning process and enhance the learners' problem – solving skills. The findings of this study might be caused from basic of instructional design principle used and the design was applied in practical for the students. This can enhance the problem – solving skill. The ID theory that used for designing the learning environment can apply to the process of problem – solving. Each component in the design such as the problem-solving training center, stimulate the students to analyze the problem in practical and present view of experts, and the experience of the experts can be the case study for the students. The finding might be caused by the teacher who keen of learning content and understand in behaviorism. The stimulation in the classroom continually can help the students in the learning process. The information technology skill of learning management also effect the research finding.

## 11. Suggestion

### 11.1. Suggestion for this research

The research finding about the quality of learning environment using constructivism concept via internet network to enhance problem – solving skill, the design of this study can be applied in developing the learning environment on the network.

### 11.2. Suggestion for further research

1. The research finding in this first phase should be studied further and the components of the design should be studied and implement for more effective learning goals.

2. The research of any effectiveness context should be further studied such as prior knowledge or experience of the learners, the context of teachers and

## 12. References

- [1] Sumalee Chaijaroen and Issara Kanjak, 2006, "Educational Technology: Transferring technology to Cognitive Technology", Cognitive Technology Journal, pp 3-7.
- [2] Ministry of Education, 2008, *Core Curriculum of Basic Education Commission 2551 B.E.*, Bangkok: Kurusapa Ladpraw.
- [3] SumaleeChaijaroen 2004. *Educational Technology and Development of Instructional Design*, Khon Kean Faculty of Education , KhonKeanUniversity.
- [4] Richy,R.C. and Klein, J.2007, *Design and development research*, New Jersey : Lawrence.
- [5] Hannafin Michel, Susan Land, Kevin Oliver. 1999. *Open Learning Environments: Foundations, Methods, and Models In Charles M.Reigeluth (Ed), Instructional Design Theories and Models: A New Paradigm of Instructional Theory*, Volume II. New Jersey, Lawrence Erlbaum Associates.



# The Recognition of 3D Photos vision by Lenticular Technique

Waiyawat Saitum, JeerapongPhudpong,  
TharadonMasuk, WatcharakonKamon  
[waiyawat.sai@kmutt.ac.th](mailto:waiyawat.sai@kmutt.ac.th) [genzneral@live.com](mailto:genzneral@live.com)  
[tharadonjeez@gmail.com](mailto:tharadonjeez@gmail.com) [Noize\\_sadz@hotmail.com](mailto:Noize_sadz@hotmail.com)

## Abstract

*The purpose of the research is to explore for the difference 3D photos and 2D photos in making observations about photography. The research processes are as follow : shooting photos, making the photo exhibition, collecting and analyzing data by using a questionnaire. The result shows that 3D photos are better than 2D photos in Human feeling.*

## 1. Introduction

Photos are important to our way of life, past and present, and each image also has an important role as a tool to communicate, whether it is education, advertising, military and medicine Etc. as evidenced by a Chinese proverb which says that "a single image than say a thousand words" and also the importance of the photo. Be a better reliability in other ways. We use in the investigation of the case in court to present evidence and events that occur. Or whether the photo to use in propaganda, retail trade, or whether it is recorded in the memory of the story. From past to present. The images are recorded with a substantial higher than the recorded value. We currently have the most natural color to convey ideas, attitudes, similar to the actual situation. To close the virtual reality.

The third dimension is likely to be increasingly popular. In everyday life we are able to watch TV or movies in three dimensions. Three-dimensional video camera and the other as a result of economic competition, the invention is comfortable for life.

For the project is interested in photography, so do the shooting have been the inspiration for the project's official recognition to the latest 3D using Lenticular to the media about campaign against drinking alcohol, which is attractive to people who passed by to get to know the changes between the motion of the moving image to be demanded attention as well. than the two-dimensional plain by the idea that the images used to capture the interest even more in the story about the campaign to drink alcohol in the youth of today to see how the drink.

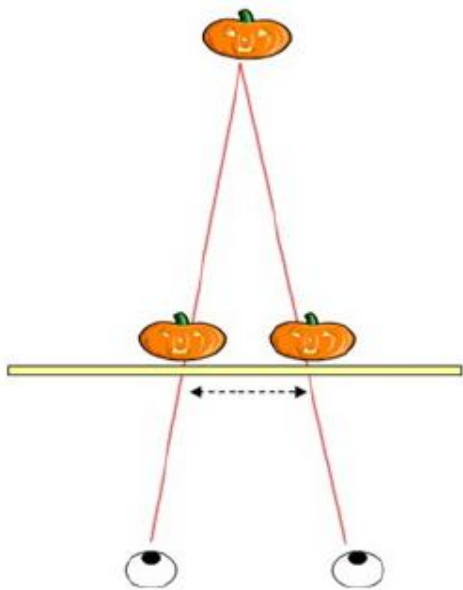
Alcohol is not immoral. Which provides that the alcohol is to blame and the consequences. Therefore, the study of the research project.

The process of recognition [1] is a process where a person is overlap between the understanding of thinking, feeling, memory, learning and decision making. The process of recognition occurs as a sequence of stimuli such as animals, objects or situations that provoke an organic cause, and when the contact with people. That person will have the effect of exposure. The intention would be to touch. It was touching to occur in the brain and the brain acts very touching experience that ever happened to cause such behavior. From the perception that they have concluded that the process of recognition of all human must go through the same process is on our environment, the organism is exposed (Sensation) through the body, eyes, ears, nose, tongue and touch the skin. We feel that through a process of recognition.

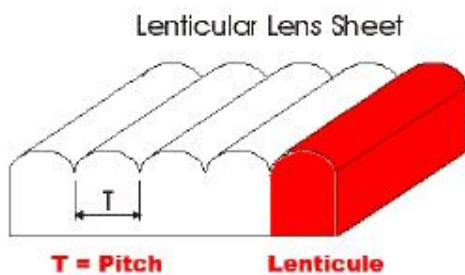
Perception is the knowledge that exposure. When the body senses of what we sent to the brain was thought to understand the perception of the brain to send commands to the body to react to behavior that occurs because of the rail body gets stimuli is based. Understanding the concept of experience and sometimes act out the emotions associated with. In psychology called "behavioral semantics" is perceived to have influence on the behavior of individuals. When the sense of touch is often perceived simultaneously with the accumulation of human knowledge since childhood. When a man is never encountered before, so know the meaning of that together with But if we find something new and have never met nor known to have never experienced or never learned it before and will did not know what it is exposed. It is the sense of touch only. The psychologist is not considered to be perception until they can be interpreted of tactile stimuli that are perceived to occur.



Theories and techniques to image three-dimensional [2] Lenticular technique is important to make two-dimensional, we see common to become a relief depth and breadth of the technique Lenticular a component. the two major parts: a sheet or sheets of plastics including Lenticular and parallel to the sheet of printing Lenticular. Figure 1 The vision of the human eye [2]. The nature of the Lenticular 3D images is a visual image refracted through the plastic compression wave is convex, so that the two pictures on the look out of place in Figure 2.



**Figure 1. The vision of the human eye**



**Figure 2. Diagram of tools**

## 2. Research Objective

1. To create 3D photos using Lenticular.

2. To compare the differences in perception between the latest photos from common 2D to 3D images.

3. To the campaign to reduce alcohol use among adolescents in the present and recognize the danger of drinking alcohol.

## 3. Methodology

The methodology for this research on the 3D Photos vision by Lenticular Technique was as follow:

### 3.1. Population and sampling group

As in this heading, they should be Times 11-point boldface, initially capitalized, flush left, with one blank line before, and one after.

**3.1.1. Experts.** Population in this study consisted of 3 experts in photos, lenticular and printing technic.

**3.1.2. Scholar.** Population in this study consisted scholar in bachelor degree from Department of Computer and Information Technology, King Mongkut's University of Technology Thonburi.

The sampling group in this study consisted of 60 scholar in bachelor degree from Department of Computer and Information Technology, King Mongkut's University of Technology Thonburi. They were chosen by simple random sampling.

### 3.2. Tools used in this research

The tools used in this research were as follow:

**3.2.1. The Recognition of 3D Photos vision by Lenticular Technique.** This project was developed in accordance following these steps:

#### 3.2.1.1. Analysis of Content

**3.2.1.1.1. The concept.** Measure it to see the difference between the latest two-dimensional three-dimensional images, which will study the visual perception and response of the photos are by comparison.

**3.2.1.1.2. Story.** A media campaign to communicate the danger of drinking alcohol, and alcohol consumption. This makes the photos are creative and social benefits. The technique is applied to the 3D photo viewer for photos, and also feel the affects of drinking alcohol in the youth of today is

too quite common in everyday life and very difficult for disallow teens not to drink. So the research represents to demonstrate the danger of drinking alcohol. In this study, researchers took pictures of all four images.

### 3.2.1.2. Study in Theories

**3.2.1.2.1. Perception of light[3].** The starting point of visibility. Is critical to the design, visual arts, because without light, we do not see any picture and if that so, there is no art to be seen. The effects of exposure to the human perception of such things as color, line, shape, texture, shape, weight of the composition. Visual arts and design, and most importantly, it is a source of light, color, leading to theories about the relationship between light and dark all the time. Color and light studies must be parallel.

**3.2.1.2.2. The perception of color.** Color have a great influence on our environment affects the feeling and expression. Learning from the evolving perception of the environment and the rules of society. Awareness about the use of color, there are no fixed rules as mathematics. The color may be extended to a wider or narrower, or may be one alone, but the perception of color depends on what we need to learn about the physical interpretation of the process physiological environment and culture. The influence of color on mood. linking the idea process, a symbol to remember and a sense of aesthetics [4].

**3.2.1.2.3 Theory associated with photography.** Camera is the process by starting the shooting of the reflected light to the object and the lens, the aperture, shutter and the light is incident on the plane of the image in the digital camera and film cameras with the same process in the light enters the camera through the lens of the camera, but came up with a different [5].

**3.2.1.2.4.Theories and techniques to image three-dimensional[2].**Lenticular technique is important to make two-dimensional, we see common to become a relief depth and breadth of the technique

**3.2.1.3. Design.** In this step, Design stories in the media campaign of alcohol present. By using the 3D makes sense to realize a negative results of the alcohol. Focus straight to feeling different from 2D and 3D photos which sent to the audience to feel and

see the difference in the two images after see the photos.

**3.2.1.4. Development.** In this step, the details and the contents about negative alcohol consumer's behavior would be added and then they were rearranged according to the scope and the story. In this step, the contents would be verified and guidance by experts for the accuracy.

**3.2.1.5. Implementation.** In this step, the photo will be shoot in studio under lighting control in 2 ways, 2D photos for simple and 3D for lenticular using.

**3.2.1.6. Evaluation.** After photos were fully developed, it would be presented to the experts to assess the quality. Then the photos would be assessed by the sampling group in terms of satisfaction.

### 3.2.1.7. Programs.

**3.2.1.7.1.Adobe Lightroom.**Is a program used to manage the photos after the shoot, then this program is to assist in the selection of photos and categories of photos are easy to find.

**3.2.1.7.2.Adobe Photoshop.**Is a program used for decorative lighting and color photos are beautiful and the world. And the size of the photo with the compression.

**3.2.1.7.3. Superflip.**Is a program for sharing photos on a 2D to make a 3D image by a set of images to match the characteristics of the Lenticular printing images have a resolution to match the setting programs to achieve 3D images.

**3.2.2. The quality assessment form.**This form was developed and classified with 6 categories as in 1) The beauty of the image, 2) The creation of the image, 3) The appropriate size, 4) The quality of the images used, 5) Sort of image, 6) The appropriate of photo's quantity. Three experts would assess the quality by this form according to Likert's scale (5 means the best quality and 1 means revision needed.)

**3.2.3. The satisfaction evaluation form.**This form was classified with 15 categories as in 1) The beauty of the image, 2) The creation of the image, 3) The appropriate size, 4) The quality of the images used, 5) Sort of image, 6) The appropriate of photo's quantity. This form was designed for the sampling

group. Since the sampling group would fill up by ticking this form according to Likert's scale (5 means the best quality and 1 means revision needed.)

### 3.3. Data collection

After the development of The Recognition of 3D Photos vision by Lenticular Technique and exhibit the images by installing both photo which is 2D and 3D images is attributed to media stories. Invites experts to evaluate all four shots and then collect the assessed valuation of the analysis to determine the quality of the photos of the latest 3D. Afterwards, the researchers revised the project according to the experts's advice and asked the sampling group to evaluate their satisfaction.

### 3.4. Data analysis

To analyze the data, there were 2 areas as follow:

1. The quality as assessed by the experts came from the mean score and standard deviation for each item and then it was compared with the following criteria: 4.5-5.0 very good quality; 3.50-4.49 means good quality; 2.50-3.49 means moderate quality; 1.50-2.49 means acceptable quality; and 1.00-1.49 means revision needed.

2. The satisfaction evaluation for the sampling group came from the data through percentage.

### 4. Research results

The results of evaluation research project to realize the vision see photos 3D using Lenticular in the media about the campaign, alcohol consumption of adolescents found that the experts can get to see the latest 3D, and understanding. the media are the result of above average quality. The perception that the difference between the latest 3D and 2D images can be attributed to the show. Photos are interested in 3D perception of the knowledge of the differences in the visual perception of 3D images using Lenticular works very well.



Figure 3. Show Lenticular's position has been attached.



Figure 4. Show changing picture.



Figure 5. Show whole series of Lenticular photos.

### 5. Conclusion

The research on The Recognition of 3D Photos vision by Lenticular Technique could be concluded and discussed as follows:

1. The Recognition of 3D Photos vision by Lenticular Technique was interesting because it could recognize, understanding and more impressive.

2. The quality assessment by the experts for The Recognition of 3D Photos vision by Lenticular Technique showed that the image's quality was at good level. The aspect with the highest mean score for the sort of image. The experts agrees that the sort of image regularly for understanding and suitable for represent in 3D than simply 2D.

3. The satisfaction of the sampling group towards on The Recognition of 3D Photos vision by Lenticular Technique showed that the majority were satisfied with all aspect of the image. The most satisfactory aspects were the appropriate of location. Which Means, they can realized that the image could transmit everyday life of them.

**Table 1. The results from the quality assessment by experts.**

Point to assessment	Mean	SD	Ideal
<b>The interest of the photo.</b>			
1. The beauty of the image.	4.00	0.52	good
2. The creation of the image.	4.11	0.76	good
<b>The technical presentations.</b>			
1. The appropriate size.	3.66	0.38	good
2. The quality of the images used.	3.66	0.38	good
3. Sort of image.	4.33	0.57	good
4. The appropriate of photo's quantity.	3.83	0.42	good
<b>Total</b>	<b>3.93</b>	<b>0.43</b>	<b>good</b>

**According to Table 1. the quality as assessed by the experts for The Recognition of 3D Photos vision by Lenticular Technique was 3.98 on average, or at good level.**

**Table 2. The results from the quality assessment by sampling.**

Point to assessment	Mean	SD	Ideal
1. The beauty of the images.	4.63	0.48	very good
2. The composition of the Images.	4.46	0.62	good
3. The appropriate of colors tone.	4.03	0.61	good
4. The fascinating perspective.	4.51	0.56	very good
5. The appropriate of lighting	4.48	0.53	good
6. The appropriate of size and aspect ratio.	3.95	0.56	good
7. The Portraits presented clearly.	4.51	0.50	very good
8. The images are appropriate for the content	4.03	0.58	good
9. The concept's communication in the image sequence.	3.70	0.46	good
10. The appropriate of location.	4.81	0.30	good
11. The appropriate of clothing and accessories.	4.55	0.50	very good
12. The emotions through eyesight and personality.	4.00	0.47	very good
13. The layout of the image	3.83	0.52	good
14. The quantity of images on the concept's presented.	3.16	0.37	moderate
15. The suitability of the material presented	3.50	0.49	good
<b>Total</b>	<b>4.19</b>	<b>0.49</b>	<b>good</b>

**According to Table 2. the quality as assessed by the sampling for The Recognition of 3D Photos vision by Lenticular Technique was 4.19 on average, or at good level.**

## 6. References

[1]SubanAudgaw, *Buddhism Cognitive Learning Theories*, Bangkok, Thailand, 2010.

[2]Bernard Mendiburu, *3d movie making stereoscopic digital cinema from script to screen*, Focus Place 30 Coperate Drive, Burlington, The United States of America, 2009.

[3]KittipongKalayos, *Comparison of the perceived distance between the distance cues in three dimensions on a computer screen*, King Mongkut's University of Technology North Bangkok, Bangkok, Thailand, 2006.

[4]Rick McCleary, *CMYK 2.0 A Cooperative Workflow for Photographers, Designers, and Printers*, Focus Place 30 Coperate Drive, Burlington, The United States of America.

[5]YaowanatPunpeng, *Digital photography*, O.S. Printing House, Bangkok, Thailand, 2010.



# The Importance of School's Commitment to Multicultural/Intercultural Education: The Case Study of Interethnic Violence in Slovenian School

Maja Zadel

Science and Research Centre, University of Primorska

[Maja.Zadel@zrs.upr.si](mailto:Maja.Zadel@zrs.upr.si)

Zorana Medarić

Science and Research Centre and Faculty of Tourism, University of Primorska

[Zorana.Medaric@zrs.upr.si](mailto:Zorana.Medaric@zrs.upr.si)

## Abstract

*In the paper we discuss the main findings of the research on interethnic violence in the school environment in Slovenia with special emphasis on the educators' role as well as the schools' commitment to promoting nonviolence and wellbeing of pupils and students regardless of their ethnic background. We present quantitative and qualitative findings of the research from three perspectives: opinions and experiences of pupils, perceptions of educators and perspectives of experts dealing with (interethnic) peer violence. Special emphasis is put on the perceptions of school environment, experiences of interethnic violence, interventions in cases of violence in schools as well as its prevention. Despite general acceptance of principles of multicultural/intercultural education in Slovenian schools as well as initiative and hard work of individual educators, a coordinated and integrated approach is needed for both, dealing with (interethnic) violence as well as transmitting values of intercultural coexistence in schools.*

## 1. Introduction

In the last decades, Europe has been facing increasing internal and external migration flows and it is therefore becoming more and more ethnically and culturally heterogeneous. Ethnic diversity is also reflected in the school environment – in an increasing number of pupils of different ethnic background. In this context, multicultural/intercultural education has been gaining importance. While multicultural education aims at respecting diversity and thus mainly acknowledges commonalities and differences between two or more cultures, intercultural education is more active in its approach, recognizing also dynamic character of cultures and the potential for enriching each other through interaction. [1].

The requests for multicultural education started in the 1960s in the USA when black people and other minorities demanded equal representation in college curricula and extra-academic cultural programmes [2]. While the Council of Europe accepted multicultural education approach already in the 1970s [3], the aspiration for a more fair representation of cultures and intercultural education has been intensified in the last years through the initiatives such as the European Year of Intercultural Dialogue, the White Paper on Intercultural Dialogue [4] and similar. Shifts are also seen in other directives such as the White Paper on Teaching and Learning: Towards the Learning Society [5], which stresses the necessity to be acquainted with other cultures, the General Policy Recommendation No. 10 on combating racism and racial discrimination in and through school education [6] issued by the European Commission against Racism and Intolerance and many others. Although there has been a number of unifying initiatives on the EU level for the inclusion of an intercultural dimension in the education, individual countries have considerable autonomy in this field. Nevertheless, current trends in European common intercultural education policies highlight mainly integration of migrant students and enhancing social cohesion [7].

While multicultural/intercultural education may be defined differently and may take various forms across countries and schools, it is important as Thijs and Verkuyten pointed out that there are some common arguments regarding the diverse and sometimes oppositional views on multiculturalism: multicultural approaches “involve fostering knowledge and an understanding of cultural differences”, where the “focus is on appreciation of diversity by acknowledging and respecting minority group identities and cultures” [8]. Also, as Luisa

Ribolzi sees the role of education in relation to multicultural reality of our everyday life, it contributes to fostering tolerance in view of overcoming nationalism [9]. Furthermore, multicultural education challenges Eurocentrism, which aims at arranging cultures on a scale where the West has a primal position, sanitizing western history and patronising/demonizing the non-West [10]. But the role of (intercultural) education is also to contribute to developing harmonious society through teaching how to understand each other, respecting others and their cultures, peaceful conflict resolutions and coexistence as well as working towards achieving mutual goals [11]. Especially today, when along with ethnic, cultural and religious diversity Europe is dealing also with greater intolerance, hostility, prejudices, discrimination and rising xenophobia towards immigrants, members of certain minorities, religious groups (e.g. Muslims) etc. At least to some extent this reality is reflected among children or young people in schools in their prejudices and stereotypes towards “others”, in differentiation between “us” and “them” and finally in different forms of peer violence, particularly name-calling.

*Multicultural/intercultural education in European context has been widely researched in the last decades [12]. On the other hand, though rarely investigated until recently, the issue of violence in ethnically diverse school has also been gaining importance [13]. School can play an important role in recognising violence as well as fostering values of tolerance, respect and solidarity and creating an environment for children where they can express themselves and feel accepted. Above all, it should transmit skills of effective intercultural communication and peaceful conflict resolution. Despite the fact that the notion of multicultural/intercultural education can be also problematic, we understand it in its ability to foster intercultural understanding and also prevent intercultural or interethnic violence.*

*In what follows, we will discuss the main findings of the Slovenian case study on interethnic violence in the school environment with special emphasis on the educators' role as well as the schools' commitment to promoting nonviolence and wellbeing of pupils and students regardless of their ethnic background. Research was part of the project Children's Voices: Exploring Interethnic Violence and Children's Rights in the School Environment (2011-2012), funded by the European Commission Fundamental Rights and*

*Citizenship Programme and implemented in Slovenia, Austria, Italy, Cyprus and United Kingdom.*

## **2. Research methodology**

*The research methodology followed a two-stage sequential design, combining quantitative and qualitative approaches. In the first, quantitative phase of research pupils aged 10-11 and students aged 16-17 were surveyed through the questionnaire consisting of 44 questions, covering demographic data, normative statements on equality and multi-ethnic background, experiences of violence, perceptions of violence, etc. In Slovenia, 767 pupils completed the questionnaire in 8 primary schools and 9 secondary schools. The schools were selected in four ethnically mixed regions, namely: Coastal region, Ljubljana region, Jesenice region and Prekmurje region. The overall gender breakdown was the following: 50.2% of male pupils in 49.8% of female pupils. Pupils in primary schools were mainly 10 (77.2%), followed by 11 (19.2%) years old. In secondary schools, the majority of pupils were aged 17 (71.2%), followed by 18 (15.2%) and 16 (12.2%). Overall, 65.7% of pupils included in the survey were of Slovenian ethnic background and 34.3% were of other ethnic background; of those, most were of Hungarian, Croatian, Serbian, Bosniac and Macedonian nationality, including a large share of mixed ethnic backgrounds (one of the parents of other ethnic background and the other Slovenian or both the parents of other ethnic background. Despite the fact the term “of mixed ethnic background” is not official category in Slovenia, in the last decades there are trends towards recognition of mixedness as social and political category [14])*

*The second, qualitative phase of research consisted of three parts: focus groups with children, interviews with school staff and interviews with experts in the field. There were 20 focus groups carried out, ten in primary and ten in secondary schools. Predominantly, participants were selected by teachers, who were asked to select according to the following criteria: gender balance, ethnic heterogeneity and loquacity – it must be noted that since the teachers chose pupils for focus groups, they may have chosen the ones who were positive about the school and intercultural coexistence. In each of the schools participating in the qualitative research, 2 in-depth interviews with school staff were conducted. In total, 20 such interviews were held.*

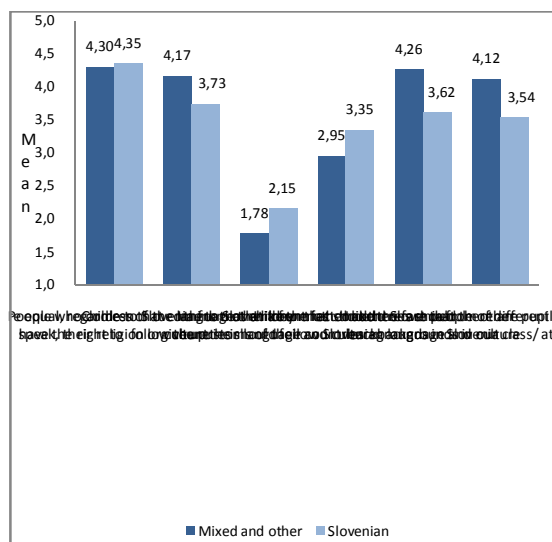
*An additional insight into the field of interethnic relations, peer-to-peer violence and similar was apprehended through interviews with experts from*

governmental and non-governmental organizations dealing with these issues. The interviews were conducted with representatives from the National Institute of Public Health, researchers at the Peace Institute, a representative of the School Students' Organisation of Slovenia, an expert from the Institute for Ethnic Studies, representatives of the Human Rights Ombudsman's Office and a representative of Unicef.

Through a mixed-method approach, we gained a layered perspective on the issue, which enabled us to apprehend differences between perceptions of different groups involved in the research. As for example, in some schools (interethnic) violence was not considered an important issue by school staff; however, the narratives of children revealed a different picture and brought into focus more covert and subtle forms of peer violence that were often not recognised as violence.

### 3. Views on equality and interethnic coexistence

First, we will focus on statements on equality and interethnic tolerance that were valued by pupils and students; these represent normative beliefs that are explicitly perspective – “they refer to the way things should be and reflect a feeling of ‘oughtness’” [15].



\*Statistically significant differences : People who come to Slovenia from other countries should have the right to follow the customs of their countries:  $V=0.215$ ,  $sig=0.000$ , Children that come to Slovenia from other countries should give up their language and culture:  $V =0.228$ ,  $sig=0.000$ , I think that

children that come to Slovenia from other countries should follow Slovenian language and culture:  $V C=0.169$ ,  $sig=0.000$ , I like the fact that there are people of different ethnic backgrounds in Slovenia:  $V=0.304$ ,  $sig=0.000$ , I like the fact that there are pupils of other ethnic backgrounds in our class/at our school:  $V =0.309$ ,  $sig=0.000$

**Figure 1.** Normatively valued equality and interethnic violence in the school environment

In general, primary school pupils and secondary school students embrace the multicultural/intercultural beliefs. They agree that *all people are equal, regardless of the language they speak, their religion or culture* (4.33), or that *people who come to Slovenia from other countries should have the right to follow the customs of their countries*(3.88). On the other hand, pupils and students mainly disagree with the negative statement toward multicultural coexistence: *children that come to Slovenia from other countries should give up their language and culture*(2.02). The most ambivalent is the statement about the Slovenian language and Slovenian culture: *I think that children that come to Slovenia from other countries should follow Slovenian language and culture*(3.22). But, if we move from the general statement to circumstances that impact their life, i.e. the school environment, the situation changes a little bit: while pupils and students still positively evaluate the fact that there are people of different ethnic background in Slovenia(3.84), they like less the fact that there are pupils/student of other ethnic backgrounds at their school/in their class (3.74).

When comparing the statements according to ethnic background, pupils/students of mixed or other ethnic background than Slovenian are generally more in favour of multicultural coexistence compared to Slovenian pupils/students. Particularly, pupils/students of other/mixed ethnic background are more in favour of the fact that there are people of different ethnic background in Slovenia or their class.

Generally positive attitudes toward multicultural coexistence and tolerance can be seen in the perspective that, as Nathan Glazer declared, “we are all multiculturalists now” [16], meaning that all, regardless of race, religion etc., have come to speak the language of tolerance and respect for cultural diversity [17]. Or, on the other hand, due to the generally accepted discourse of promoting tolerance and reducing prejudice and discrimination, students tend to express only desirable opinions [18].



This was also seen in the discrepancies between the pupils' and students' responses to the normative statements and the discussion of focus groups. In the focus groups discussions, stereotypes and prejudices about people of different ethnic background as well as

intolerance were often expressed:

*But this is weird isn't it? Because when we go to their country, women have to clothe and wear headscarves. Here, they can just walk around in headscarves, can't they? (m, 17)*

*It's strange that someone lives in Jesenice for 20 years and doesn't know one Slovenian word. (f, 17)*

The above mentioned cases reflect the conservative/corporative understanding of multiculturalism that tries to cover up the ideologies of assimilation, where "others", before they can become part of the host society, must adopt a consensual view of culture, where "ethnic groups are reduced to 'add-ons' to the dominant culture" [19].

#### **4. Hierarchy of "otherness"**

In contrast to previously normatively expressed equality of all people, when referring to "others", i.e. people of different ethnic background, there is also an evident differentiation between nations from Western or Northern parts of Europe and South-Eastern parts of Europe (like Bosnia and Herzegovina, Albania, Macedonia, Serbia, etc.). According to pupils, Western and Northern nations "are more civilised" and differentiation between nations is a consequence of "not being equal" – which is exactly the opposite to the normative statement they agreed mostly with (all people are equal, regardless of the language they speak, their religion or culture). As a pupil explained:

*Because countries like France and England are more developed than Macedonia or Bosnia or [other Balkan countries]. (f, 10).*

This kind of differentiation can also be observed in the Slovenian public opinion where immigrants from ex-Yugoslav countries, Asia, Africa, etc. are less "desired" compared to immigrants from Western Europe, USA or Australia [20].

Research revealed strong and numerous prejudices towards immigrants from Balkan countries and Roma that are, also according to other research, the least respected ethnic group in Slovenia [21]. They are exposed to intolerance and stereotyping also in other European countries [22]. Numerous prejudices towards Roma were expressed during discussions with pupils:

*They think they are chiefs, but they are not. (f, 17)*

*And they do not feel like working. (m, 17)*

*And there is waste around their cottages. (f, 17)*

*They are disorderly. (f, 17)*

*They are unclean. (f, 18)*

*And are only stealing from the country. (f, 17)*

*(laughter)*

Pupils/students are quite aware of the differences among nations and cultures and despite normatively expressing equality do not see everyone as equal regardless of ethnicity, religion, culture or language. Opinions revealed through focus groups discussions show that friends, even if of different ethnicities, are often exempt from negative judgements. This leads to two conclusions: (1) although they are aware of the prejudices towards the ethnicity of their friends on one hand and their friends' positive characteristics on the other, it usually does not diminish their prejudices and (2) there is probability that pupils and students of different ethnicities, cultures and religion without Slovenian friends are more likely to experience discrimination in comparison to those who already have Slovenian friends (e.g. newcomers).

#### **5. Perception and experience of interethnic violence**

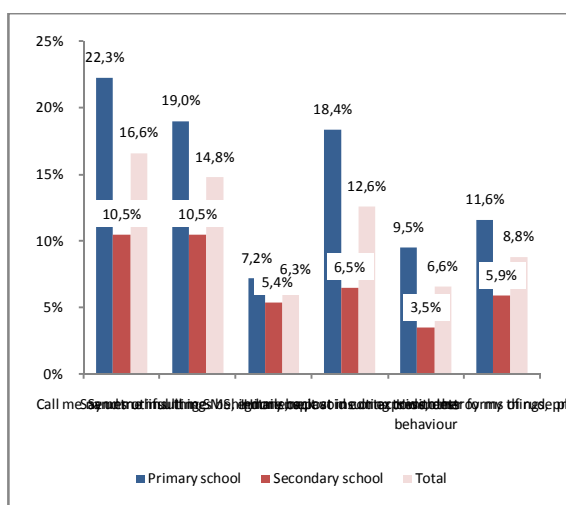
Even though, the application of principles of multicultural/intercultural education were not introduced with the explicit objective of prevention of interethnic violence, its main aim, to foster interethnic and intercultural understanding and understanding diversity, helps also diminishing the occurrence of intercultural/interethnic violence. In our study interethnic violence was not recognised as a major issue at schools included in the research; as a matter of fact, it was recognised nearly as non-existent. School staff in rare cases exposed some examples of interethnic violence – headmasters as the primal representatives of schools were especially prone to present their school as violence-free. It might be, as experts explained, also denied as a problem:

*/.../ for some parts of Slovenia a fairly strong tendency and assertion are pointed out: here, there's no violence, especially interethnic violence, there's no such thing, even if, on the other hand, there are evidences of its existence. And also the denial of schools that this problem even exists... (researcher, Peace Institute)*

It is also in line with previous research that teachers generally underestimate the occurrence of violence in school [23]. The researcher from the Peace Institute similarly observed that especially in the case of immigrants, school authorities are concerned primarily with the language difference and violence is not understood as a problem:

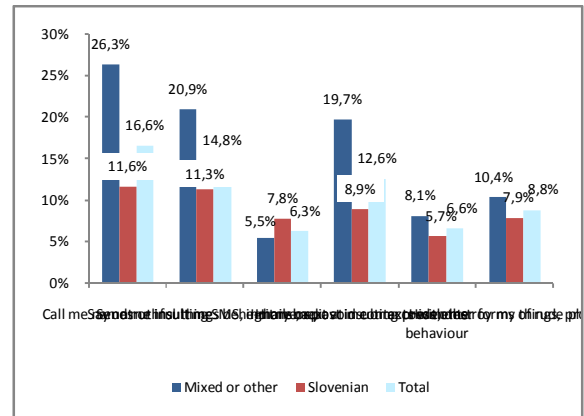
*Here, I think that schools rather individually, alone, as they see best, and especially individual teachers or professional staff of schools deal with individual cases of migrant children who come as the first generation ... each in their own way, they deal with children of the first generation migrants – especially from Albania, Bulgaria, Kosovo, Romania – and in such cases, the emphasis is not on violence when including these children to schools, but on the language. That is to say, the language is a problem, all the rest isn't. That was the impression I got. Here the violence is taken as a problem of discipline and not ethnic, class, gender conflicts, identity conflicts ... /.../ (researcher, Peace Institute)*

Even though interethnic violence was generally not seen as an important issue some occurrence of interethnic violence can be observed through the results of the survey: cases of physical violence were actually rare, while other, subtler forms of violence were more widespread, e.g. name-calling, talking behind someone's back and avoiding. Differences in responses are seen between primary school pupils and secondary school students, where the former experience interethnic violence more frequently, and between pupils and students of Slovenian background and those of other or mixed ethnic backgrounds, where the latter experience interethnic violence more frequently.



\*Statistically significant differences for name-calling ( $V=0.159$ ,  $sig=0.000$ ), talking behind someone's back ( $V=0.120$ ,  $sig=0.001$ ), avoiding ( $V=0.181$ ,  $sig=0.000$ ), rude physical behaviour towards persons ( $V=0.121$ ,  $sig=0.001$ ) or property ( $V=0.100$ ,  $sig=0.006$ ).

Figure 2. Have you ever experienced interethnic violence? (age)



\*Statistically significant differences for name-calling ( $V=0.188$ ,  $sig=0.000$ ), talking behind someone's back ( $V=0.129$ ,  $sig=0.000$ ), avoiding ( $V=0.154$ ,  $sig=0.000$ ).

Figure 3. Have you ever experienced interethnic violence? (ethnic background)

The above mentioned, more subtle and hidden forms of violence are difficult to identify and are often not recognised as violent behaviour, also by those who experience it. For example, a Macedonian girl, denied any negative experience in school due to her ethnic background, but in a conversation, other participants mentioned that they did not socialise with her at the beginning when she joined their class, on which she commented:

*Yeah, sometimes they are avoiding me, but it doesn't bother me. (f, 10)*

Furthermore, some kind of "reverse blaming" could be observed: individuals of others ethnic group were sometimes blamed for their social exclusion:

*I think that those who are of different ethnic background are usually more...reserved /.../ but I think it is because they fear they wouldn't to be accepted, not because we would not actually accept him/her. (f, 17)*

When directly asked about the occurrence of interethnic violence and their experiences, pupils did not see interethnic violence as present in their school, but after being explicitly asked about specific forms,

e.g. name-calling, avoiding, everybody knew remembered a case, or was him/herself victim of interethnic violence. It is the subtle, more covert forms of (interethnic) violence as well as new forms of violence (cyberbullying) that educators should be particularly sensitive to, as it is important to detect these less visible forms of violence in order to apply effective interventions. Therefore, the educators should, as Strohmeier and Noam [24] say, learn (1) how to detect violent behaviour,(2) how to distinguish light from serious cases as well as intervene differentially with bullies, victims and bystanders and (3)how to prevent bullying, all with particular attention to ethnic diversity.

Our research revealed that ethnicity *per se* is usually not an important motivator for peer violence. It is a combination of characteristics – age, gender, physical characteristics, socio-economic class that defines it.It is only when the conflict enhances that it becomes an important characteristic of identification and differentiation through, for example, use of ethnic slurs:

*It's really when they can't cope with the problems and conflicts, that they start using the insults, that are not necessarily [laugh] directed, like even if they say "Bosan'c"[Pejorative for an inhabitant of Bosnia andHerzegovina.] they don't necessarily mean a member of a nation, it's like an insult, but that's just defence when they can't solve something. (schoolcounsellor, primary school)*

## 6. School context, reactions to (interethnic) violence and prevention strategies

School context and especially school and class climate have been found to be very important for prevention of school violence [25], especially caring and supportive climate with established trust among students, teachers, school staff and parents.Educators'role,is very important in this matter. It could be argued that teachers and other school staff have the ethical and legal responsibility to create and maintain a protected atmosphere. Their involvement in the relationships of pupils and students and their concern for their well-being, or the lack of it, is quickly recognised by pupils and students, especially in the case of school violence:

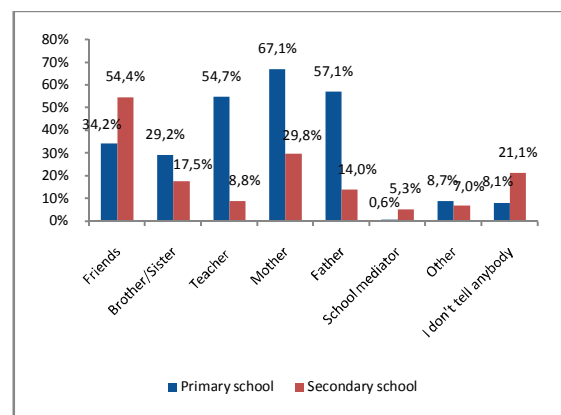
*It depends on the teacher. The one we had last year ... she didn't intervene! We had to pull them apart, she didn't do a thing! As if nothing happened. She pretended she was writing something. (m, 12)*

According to previous research there also exist differences between educators and students regarding the perception of the frequency of intervention in bullying – usually teachers perceive their intervention as more frequent than students [26].According to interviews with teachers they always intervene, however pupils reported some cases of non-intervention.

*Of course, I always intervene. We try to resolve these issues by shedding light on a person's feelings, what does it mean, how does someone feel? So that a child can understand the meaning behind words [in case of name-calling]. (school counsellor, primary school)*

*If the children need me, I intervene. If I am informed about the violence, I do. If I am not, then I don't. But if I am, I always intervene. (school counsellor, primary school)*

Also, differences in the teachers' role can be observedbetween primary and secondary school: while primary school pupils reported that teachers intervene almost always (66% always and 30% sometimes), secondary school students saw teachers' intervention as less frequent (66% sometimes and 18% always). Similarly, primary school pupils to a greater extent confide with their teachers when experiencing violence than secondary school students, who usually tell their friends or nobody.



**Figure 4.**Who do you tell when you experience interethnic violence? (age)

Particularly younger pupils see the role of the teachers as the ones to intervene in cases of violence in schools:

*The best way is to defend yourself or to tell the teacher if it happens in school, if it happens outside school you tell your parents. And if the bully is from another school, you should go and tell people from that school. (m, 10,)*

Through the focus group discussions this notion was further elaborated: one of the main responsibilities of the primary school is also education in the sense of values (besides the family the primary school is the institution involved in raising children and fostering values of tolerance and intercultural understanding), while the secondary school is seen more as learning for-the-job education and to a lesser extent as an institution concerned with teaching of values. Family is seen as the most important environment for prevention and dealing with interethnic violence by both, pupils and experts:

*I do not know. In my opinion, it all [education for non-violence and tolerance] starts within the family. (m, 18).*

*First, school is a governmental institution and its role is education and this is its primary role. Looking broader, it is the responsibility of parents. Parents are those, who have responsibility, and then is school. (representative of the School Student's Organisation of Slovenia)*

Nevertheless, the importance of school was also stressed, particularly by primary school pupils:

*We should talk more about this in class. (f, 10)*

When asked about the responsibility for dealing with interethnic violence, the school counsellor in primary school stressed the importance of the active role of every individual, especially of the school staff:

*Here it is hard to define one [responsible], because we all are [responsible]. There it is the teacher, schoolmates, if [we follow] the principles to respect others, that everybody has the right to go to school and be successful at that, to develop his/her competences and others don't have the right to restrict it. These duties derive already from the basic principles of elementary schools, such as the right to education. Everybody, the whole school has to be responsible. Neither the cook nor the janitor should be excluded. We are all bearers. Of course, mostly teachers, who teach children. (school counsellor, primary school)*

In this view, the "role model argument" seems important. Pupils and students of all ethnicities and cultures deserve teachers that will assume their competence and encourage them to do their best. But, as it turns out, not all teachers are "culture-blind" and treat their pupils and students equally. Although the majority of pupils and students agree that teachers treat pupils/students the same way regardless of their nationalities/ethnic background (cultures, languages, religions) – primary school pupils agree more (4.23)

than secondary school students (3.38). Some cases of unjust grading in secondary school were reported:

*Yes, we have a professor who does not accept them [non-Slovenian students] and this is evident... /.../ when it comes to giving grades, it is not objective, in case when essays are graded, etc. (m, 16).*

A school counsellor mentioned a case of psychological violence of a male teacher of other ethnic background towards pupils of the similar ethnic background as his. He was more demanding, rough and intolerant towards these pupils:

*I managed to make something out of myself, what about you? Are you just going to stroll around being lazy? (school counsellor, primary school)*

But, as Anita L. Allen points out, being of the same or similar ethnic backgrounds, is neither a necessary nor a sufficient condition for being a role model [27]. Again, the main point is that every student deserves a teacher who will try to be a role model, regardless of the student's or teacher's nationality, race or culture. Primary school pupils mentioned some cases of additional encouragement and devoting more time to pupils of other ethnic background.

Teachers' role in addressing the needs of children and youth of other ethnic backgrounds seems even more important; when comparing the responses of children of Slovenian background and those of other or mixed ethnic background who do they tell about the experienced interethnic violence, it can be seen that pupils (beside friends) and students of other or mixed ethnic do not disclose their experience of interethnic violence as frequently as their Slovenian peers. In this sense, teachers could become the persons who they confide into.

Teachers' role seems crucial also if we look at the places where interethnic violence usually occurs – places where teachers' presence and supervision are insufficient or missing altogether: school corridors (51%), school playground/courtyard (44%), on the way to school/from school (38%), in the classroom (36%), in the locker area (31%) and lately in the cyberspace.

Introducing simple methods to prevent violence and foster intercultural understanding is always welcoming, but an integrative/holistic approach, which is still missing, may be more effective:

*The role of the state...we miss common guidelines, circulars that would inform the school staff how to*

*recognize various forms of violence, how to deal with the occurring violence. (Deputy Ombudsman)*

Therefore, every school is somehow left to itself to manage the cases of violence. Nevertheless, some common practices were observed. Most participants mentioned the “zero tolerance towards violence”, since they see this approach as the most appropriate response for violence prevention as well as gaining pupil’s trust.

*We have a zero tolerance policy towards violence. Violence shouldn’t be tolerated ... we react immediately, decisively and we stop it the moment it happens. (teacher, secondary school)*

However, as previously discussed, only physical violence is often perceived as violence. Not merely by pupils and students, but by teachers, too. So, when physical violence occurs, the school personnel generally interfere, but when it comes to subtle forms of violence, such as name-calling, avoidance, etc., it usually depends on their social sensitivity.

*Usually they [the teachers] interfere, but sometimes they say we should settle things among ourselves. (m, 10).*

However, as two researchers of the Peace Institute pointed out, zero tolerance may not be the best approach in violence prevention since violence is blocked, forbidden and disciplined, but often reasons for the conflict are not discussed. In some interviews with school workers, the awareness of this problem was evident – it is not enough to stop violence, they think it is just as important to discuss about the cases. A primary school social worker explained that the process of solving misunderstanding and violent behaviour takes a lot of time and they implement it in several steps.

*I always go for the confrontation. First, to calm things down. The first phase is always the calmness. The second phase is a container, when you listen. The third phase is when you try to find some sort of a constructive dialogue. To find the motives, explanation, this is always the next phase, the next day. I am not in favour of punishment, I stand for internal, personal changes and this takes more time. We meet several times to solve one case. I don't like hasty reactions. Not on national, religious, cultural, not on any other level. (school counsellor, primary school)*

Several other interviewees acknowledged the importance of constructive dialogue:

*We try to resolve these issues by shedding light on a person’s feeling, what does it mean, how does someone feel? So that a child can understand the*

*meaning behind words [in case of name-calling]. (school counsellor, primary school)*

*Constructive dialogue, this is the first step. Then further, if this doesn’t help, but dialogue is the first thing. To discuss the reasons, why it happened, what to do that something like that wouldn’t happen again. Disciplinary sanctions are the last resort. You have to discuss such matters promptly, the minute it happens. Because zero tolerance means exactly that, it shouldn’t be tolerated. (sociology teacher, secondary school)*

*In case of physical violence you have first to separate the pupils involved, then we talk with the victim, we talk with the perpetrator, then we involve the parents, the teachers ... Some resolutions have to be taken ... If I walk on the corridor and I see such things I always react. Or if children come to me with their teachers or their parents, sometimes I get phone calls, sometimes I call the parents and I am trying to find a solution. (school counsellor, primary school)*

An integrative approach is crucial since, as researchers of the Peace Institute pointed out, the roles of perpetrators, victims and witnesses are usually overlapping and individuals often appear in all three roles, which is also true for interethnic conflicts.

Besides a constructive dialogue, also talking about violence and intercultural understanding is considered important, which was stressed by pupils, too:

*We should talk about it [different cultures and religions, human rights] more often in class. (f, 10)*

In this regard, the school staff believes that the best way to prevent interethnic conflicts and violent behaviour at school is to apply the principles of interculturalism and tolerance in the curriculum. Primary school pupils and secondary school students estimate that *in the class they learn about different cultures and religions* (primary school pupils with the mean 3.82, and secondary school students with the mean 3.58;  $V=0.158$ ,  $\text{sig}=0.001$ ), and *have special activities that encourage them to be equal and understand their differences*, which is more common among pupils (3.98) than students (2.69) ( $V=0.486$ ,  $\text{sig}=0.000$ ). Here again the difference between teaching of values in primary schools and teaching of subjects in secondary is visible. Secondary school students have less activities for intercultural understanding, while they have many subjects where they get to know other cultures, such as Geography, History, Slovenian and foreign languages, Education for Peace, Family and Non-violence. In this regard teachers and experts expressed the opinion that one

subject is not sufficient to teach the children to respect diversity. In their view, interculturality as an educational principle should pervade all school activities, from the youngest age, while the majority of subjects mentioned are taught in the last years of primary school or secondary school and usually do not address the relevance of intercultural understanding directly (with the exception of Ethics and Civil Education) – intercultural values are mainly present on the declarative level. However, some teachers and other school staff try to make use of them even in everyday situation, not just as a matter of school subjects:

*For example, when a new pupil comes in the classroom I always try to work on their social skills, to engage them in social games, role playing, for example 'get to know me', or 'ask me a question'. This really, really helps since the process of getting to know someone evolves quickly and the level of trust as well. I think that it really helps them to get rid of their uncertainties and prejudices ... (teacher, primary school)*

*I try to find a pupil in school who comes from the same country, who speaks his or her language and he becomes a kind of a mentor to this student. I have positive experiences with this. It can really help. (school counsellor, secondary school)*

Unfortunately, not all teachers are so forthcoming. A school counsellor reported about the case of tensions between a teacher and a parent when the teacher declared: "I'll talk with the lady, when she'll speak Slovenian!" In this situation the school counsellor took the role of the translator, so that the mother could get some feedback of her child's school progress.

Teachers and other workers thus become cultural and linguistic mediators. Similarly, Henry A. Giroux sees the benefit in promoting educational practices that encourage students, teachers and other school workers to become "border crossers engaged in a critical and ethical reflection about what it means to bring a wider variety of cultures into dialogue with each other" [28].

Such an inclusive environment certainly creates a positive school climate. In some schools teachers and others mentioned practices to improve the school climate – generally it seems that there are fewer tensions among students in the environment where children/students have the possibility to relax during breaks, engage in sports activities and communicate with teachers:

*It largely depends on the school atmosphere. If a school is more productively oriented, this is*

*expressed in rising violence, both in didactic issues and issues concerning nationality. If a school is more liberal and it enables children to relax during breaks, to play football, talk with their teachers in hallways, then tension is dispersed regardless of nationality problems. (school counsellor, primary school)*

In the light of the cases mentioned, it seems that at least some teachers and other school personnel are trying really hard to educate children in the spirit of intercultural understanding and acceptance. On the other hand, there are still many things that could be improved. Namely, despite their initiative, educators sometimes lack time and financial resources or training to effectively tackle (interethnic) school violence. There are many programs and initiatives, but there is no coordinated or integrated approach in tackling school violence problems in Slovenia.

*Well, I think there's a big problem in Slovenia that a whole bunch is trying to do something, change something, but no one can pull all the strings together so that the thing could work. (representative of National Institute of Public Health)*

## 7. Conclusion

While nowadays multiculturalism has been recognised as an important part of everyday life: *.../ Coexistence has become a value, being different is a right. Consequently, people declare their difference. .../ (researcher, Institute for Ethnic Studies)*, we are at the same time still facing intolerance, hostility, prejudices towards "others" (migrants, minorities) perpetuated through media and political discourse. To some extent this was reflected also through our results. Despite the fact that school sometimes works as a "protected space" [29], it is not cut off from the wider society and as it could be seen, at least to some extent, children and youngsters express stereotypes, differentiation between "us" and "them" as well as report about interethnic violence in schools. Although it can be said that interethnic violence in the Slovenian school environment is not widespread, some cases of different forms of violence, particularly psychological, more covert, were observed. Here, however, it is important to draw attention to the interplay of different factors in peer violence, ethnicity being just one of them, recognised in our and previous studies [30].

Since school is a crucial context of secondary socialisation where children spend a considerable amount of time, overall school climate and educators can play an important role in transmitting values of intercultural coexistence as well as violence

prevention. In the case of interethnic violence in the school environment it can be seen that educators generally pursue these goals, but there are a few important points to be considered: first, subtle and covert forms of violence (also in the case of interethnic violence) are difficult to recognise and therefore it is important for educators to learn how to detect them in order to react in an appropriate way. Second, with regard to detecting and reacting to (interethnic) violence there do not exist any common guidelines or directives for educators who miss additional education in this field– alot depends on educator’s social sensitivity and own initiative. Despite several programmes in the field of prevention of violence offered by governmental and nongovernmental institutions, they are often limited and of short duration due to the lack of financing. These programs are also very fragmented. Third, even though the principles of intercultural education have been widely accepted in Slovenian schools, educators express the necessity for a more coordinated and integrated approach in this field, too. Implementation of interculturality as an educational principle, therefore permeating all school activities, still to a large degree depends on personal initiative of educators.

Schools can certainly make an important difference by providing “safety, a sense of belonging, and a valuing of diversity” [31] as for example demonstrated by a case study on Islamophobia in England. It is true, however, that schools are set in a wider context; thus, it is crucial to include local communities as well as national level policies in fostering values of intercultural tolerance, respect and coexistence as well as combating interethnic violence in school. An integrated approach is essential especially in the current times of socioeconomic crisis when interethnic and interreligious conflicts and intolerance are increasing.

## 8. References

[1] A. Portera. “Intercultural education in Europe: epistemological and semantic aspects.” *Intercultural Education*, 2008, 19, 6, pp. 481–491.

[2] T. Turner, “Anthropology and Multiculturalism: What is Anthropology that Multiculturalism Should Be Mindful of It?”, Goldberg, D.T. (ed.): *Multiculturalism: A Critical Reader*, Blackwell, Oxford, 1995, pp. 406-425.

[3] A. Portera. “Intercultural education in Europe: epistemological and semantic aspects.” *Intercultural Education*, 2008, 19, 6, pp. 481–491.

[4] Council of Europe, “White paper on intercultural dialogue: Living together as equals in dignity”, CM, Council of Europe, Strasbourg, 2008, 30.

[5] European Commission, “The white paper on teaching and learning: Towards the learning society”, Office for Official Publications of the European Communities, Luxembourg, 1996.

[6] ECRI, “General recommendation No 10 on combating racism and racial discrimination in and through schools education”, Council of Europe, Strasbourg (2006).

[7] D. Faas, C. Hajisoteriou, P. Angelides, “Intercultural education in Europe: policies, practices and trends” *British Educational Research Journal*, 2013.

[8] J. Thijs, and M. Verkuytem, “Multiculturalism in the classroom: Ethnic attitudes and classmates’ beliefs”, *International Journal of Intercultural Relations*, Elsevier Ltd., 2013, pp. 176-187, pp. 177.

[9] L. Ribolzi, “Between Inclusion and Marginality: The Role of Education in Migrant Children”, *Journal of Social Science Education*, June 2007, pp. 45-56.

[10] R. Stam, E. Shohat, “Contested Histories: Eurocentrism, Multiculturalism, and the Media”, D.T. (ed.): *Multiculturalism: A Critical Reader*, Blackwell, Oxford, 1995, pp. 296-324.

[11] L. Tăușan, “The European dimension of education – a way to promote intercultural education”, *Educatia*, 2011, 21, 9.

[12] A. Portera. “Intercultural education in Europe: epistemological and semantic aspects.” *Intercultural Education*, 2008, 19, 6, pp. 481–491; F. Heckmann, Education and migration: Strategies for integrating migrant children in European schools and societies, 2008, European Commission, Brussels.; D. Faas, C. Hajisoteriou, P. Angelides, “Intercultural education in Europe: policies, practices and trends” *British Educational Research Journal*, 2013; J. Thijs, and M. Verkuytem, “Multiculturalism in the classroom: Ethnic attitudes and classmates’ beliefs”, *International Journal of Intercultural Relations*, Elsevier Ltd., 2013, pp. 176-187.



- [13] M. Verkuytem and J. Thijs, "Multiculturalism among minority and majority adolescents in the Netherlands", *International Journal of Intercultural Relations*, Elsevier, 2002, 26, pp. 91-108; D. Strohmeier, C. Spiel, P. Gradinger, "Social relationships in multicultural schools: bullying and victimization", *European Journal of Developmental Psychology*, 2008, 5, pp. 262-285; M.H.M. Vervoort, R.H.J. Scholte, G. Overbeek, "Bullying and Victimization Among Adolescents: The Role of Ethnicity and Ethnic Composition of School Class", *Journal of Youth and Adolescence*, 2010, 39, 1, pp. 1-11; E. Stefanek, D. Strohmeier, R. van de Schoot, C. Spiel, "Bullying and Victimization in Ethnically Diverse Schools", *Migrations: Interdisciplinary Perspectives*, Springer – Verlag 2012, pp. 79-88; J. Tolsma, I. van Deurzen, T. H. Stark, R. Veenstra, "Who is bullying whom in ethnically diverse primary schools? Exploring links between bullying, ethnicity, and ethnic diversity in Dutch primary schools", *Social Networks*, Elsevier, 2013, pp. 51-61.
- [14] M. Sedmak, "Kulturamešanosti. Družbeno in politično prepoznavanje socialne kategorije mešanih ljudi", *International Annales, Series Historia et Sociologia*, 2011, 21,2 pp. 261-274.
- [15] J. Thijs, and M. Verkuytem, "Multiculturalism in the classroom: Ethnic attitudes and classmates' beliefs", *International Journal of Intercultural Relations*, Elsevier Ltd., 2013, pp. 176-187, pp. 177.
- [16] D. Hartman, J. Gertis, "Dealing with Diversity: Mapping Multiculturalism in Sociological Terms", *Sociological Theory*, American Sociological Association, New York, June 2005, pp. 218-240, pp. 218.
- [17] D. Hartman, J. Gertis, "Dealing with Diversity: Mapping Multiculturalism in Sociological Terms", *Sociological Theory*, American Sociological Association, New York, June 2005, pp. 218-240.
- [18] J. Stiehm, "Diversity's Diversity", Goldberg, D.T. (ed.): *Multiculturalism: A Critical Reader*, Blackwell, Oxford, 1995, pp. 140-156.
- [19] P. McLaren, "White Terror and Oppositional Agency: Towards a critical Multiculturalism", Goldberg, D.T. (ed.): *Multiculturalism: A Critical Reader*, Blackwell, Oxford, 1995, pp. 45-74, pp. 49.
- [20] S. Zavratnik Zimic, A. Kralj, Z. Medarić, B. Simčič, "Migracije, integracija in multikulturalnost – kontekstualizacija sodobnih migracijskozijskih javnomnenj: zaključno poročilo ciljno-raziskovalnega projekta "Integracijske politike vzpostavitve evalvacijskega modela in instrumentov longitudinalnega monitoringa", Univerza Primorskem, Znanstvenoraziskovalno središče Koper, Koper, 2008.
- [21] N. Toš et al., "Vrednote v prehodu IV. Slovensko javnomnenje 2004–2009", Fakulteta za družbene vede, Ljubljana, IDV – CJMMK.
- [22] European Union Agency for Fundamental Rights, "The situation of Roma in 11 EU Member States - Survey results at a glance", Publications Office of the European Union, Luxembourg; A. Kirbiš, S. Flere, M. Tavčar Krajnc, "Netolerantnost v Sloveniji in Evropi: primerjalna in longitudinalna analiza", *Družboslovne razprave*, Slovensko sociološko društvo and Fakulteta za družbene vede Univerze v Ljubljani, Ljubljana, 2012, 28, 70, pp. 27-50; B. Sauer, E. Ajanovic, "Schools as a "Protected Space"? Good Practices but Lack of Resources", Z. Medarić, M. Sedmak (eds.): *Children's Voices: Interethnic Violence in the School Environment*, University of Primorska, Science and Research Centre, Annales University Press, Koper, 2012, pp. 83-120; G. Delli Zotti, O. Urpis, "Educational Institutions in the Face of Multiculturalism: Problems and Solutions to Interethnic Violence in Italian Schools", Z. Medarić, M. Sedmak (eds.): *Children's Voices: Interethnic Violence in the School Environment*, University of Primorska, Science and Research Centre, Annales University Press, Koper, 2012, pp. 121-169.
- [23] D. Strohmeier, G.G. Noam, "Bullying in Schools: What is the problem and how can educators solve it?", *New Directions for Youth Development*, Wiley Online Library, Spring 2012, pp. 7-13.
- [24] D. Strohmeier, G.G. Noam, "Bullying in Schools: What is the problem and how can educators solve it?", *New Directions for Youth Development*, Wiley Online Library, Spring 2012, pp. 7-13.
- [25] Barrios et al., McEvoy and Walker, Spratt in M.B. Greene, "Reducing Violence and Aggression in Schools", *Trauma Violence Abuse*, 2005. 6, 5, pp. 402-412.



[26] D. Pepler, W. Craig, S. Ziegler, A. Charach, "An evaluation of an anti-bullying intervention in Toronto schools", *Canadian Journal of Community Mental Health*, 1994, 13, 2, pp. 95-110 in D. Strohmeier, G.G. Noam, "Bullying in Schools: What is the problem and how can educators solve it?", *New Directions for Youth Development*, Wiley Online Library, Spring 2012, pp. 7-13.

[27] A. L. Allen, "On Being a Role Model", Goldberg, D.T. (ed.): *Multiculturalism: A Critical Reader*, Blackwell, Oxford, 1995, pp. 180-199.

[28] H. A. Giroux, "Insurgent Multiculturalism and the Promise of Pedagogy", Goldberg, D.T. (ed.): *Multiculturalism: A Critical Reader*, Blackwell, Oxford, 1995, pp. 325-343.

[29] B. Sauer, E. Ajanovic, "Schools as a "Protected Space"? Good Practices but Lack of Resources", Z. Medarić, M. Sedmak (eds.): *Children's Voices: Interethnic Violence in the School Environment*, University of Primorska, Science and Research Centre, Annales University Press, Koper, 2012, pp. 83-120.

[30] T. Žakelj, A. Kralj, "It Doesn't Happen in Our School": Ethnicity as a Structural Factor of Peer Violence in Slovenian Schools. Z. Medarić, M. Sedmak (eds.): *Children's Voices: Interethnic Violence in the School Environment*, University of Primorska, Science and Research Centre, Annales University Press, Koper, 2012, pp. 27-83; M. Hrženjak and Ž. Humer, "Intersekcionalni pristop v preventivnih programih preprečevanja medvrstniškega nasilja" *Socialna pedagogika*, Združenje za socialno pedagogiko, Ljubljana, 2010, 14, 1, pp. 63-82; M. Busche, E. Scambor, O. Stuve, "An Intersectional Perspective in Social Work and Education", *ERIS web journal*, 2012, 1. Ostrava, pp. 2-14; A. Peguero, "Schools, Bullying, and Inequality: Intersecting Factors and Complexities with the Stratification of Youth Victimization at School", *Sociology Compass*, 2012, 6,5, pp. 402-412.

[31] S. Inman, P. McCormack, S. Walker, "Wearing your own Culture": a Study of Islamophobia in English Schools", Z. Medarić, M. Sedmak (eds.): *Children's Voices: Interethnic Violence in the School Environment*, University of Primorska, Science and Research Centre, Annales University Press, Koper, 2012, pp. 171-220.

## **A Development of Online Multi - Media Lesson Using Cues on the Topic “Composition”**

Asst. Prof. Dr. Sapon Meejaleurn, Miss Patthira Krongrati

*Faculty of Industrial Education and Technology, King Mongkut's and  
Technology King Mongkut's University of Technology Thonburi  
[sapon.mee@kmutt.ac.th](mailto:sapon.mee@kmutt.ac.th) [patthira@hotmail.com](mailto:patthira@hotmail.com)*

### **Abstract**

*This research was to develop online multi-media lesson using cues on the topic “Composition” and to study the quality of the lesson, to study the learning achievement of online multi-media lesson and to study the satisfaction of the students who studied online multi-media lesson using cues on the topic “Composition”. 1) online multi-media lesson using cues on the topic “Composition” 2) online multi-media lesson evaluation form 3) learning achievement test 4) satisfaction evaluation form. The 30 first year students of fine art department, Saowabha Vocational College were simple random sampled. The research design was randomized one-group pretest-posttest design. Data was statistically analyzed by t-test for dependent. The research findings were that the online multi-media lesson using cues on the topic “Composition” was presented in form of multi-media with sounds, graphics, and illustrations. The students studied by online learning with the use of cues in the lesson, trace for the students as the stimulus for more responding. The cues such as bold letter, changing letter's colors, color strips, could stimulate the learners to study and understand more in the lessons. The content evaluation found that the average was 4.39 and standard deviation was at 0.34 which referred to the quality was at the level of “good”. The evaluation for media production quality was found that the average was 4.74 and standard deviation was at 0.18 which referred to the quality was at the level of “very good”. The posttest of learning achievement was significantly higher than posttest at the level of .01 and the satisfaction of students to the online multi-media lessons had the means of 4.47, the standard deviation was 0.50 that referred to the level of “most”. The results of the research showed that the online- media lessons can be used in the instruction.*

### **1. Introduction**

Online learning using multi-media of sound, graphic, and illustration via the internet is more important nowadays. The students can learn anywhere, anytime through online learning. The way of instruction help the students to understand the content and interested to the lessons and enhance the concept completion [1] and the use of cues to stimulate and increase the opportunity of students' response such as bold letter, changing letter's colors, color strips to stimulate the students' interest and more content understanding. [2]

A course of composition concerns about lines, appearances, shapes, colors, points, textures, and light. This course is for the first year certificate student of fine art department, Faculty of Arts and it can be applied in creating fine art works, sculpture, architectural prints, and photography. [3] Beside the application of composition for applied arts and design works, the researchers aim to study the production of online multi-media lessons using cues to enhance the students' knowledge of composition.

### **2. Objectives**

1. To develop and gain the quality of online-media lessons using cues on the topic “composition”.
2. To study the learning achievement of the students toward the online media lesson using cues on the topic “composition”.
3. To study the satisfaction of the students toward the online media lesson using cues on the topic “composition”.

### **3. Expected Benefits from the Research**

1. To gain the qualitative online-media lessons using cues on the topic “composition” for the first year certificate students of fine art department, faculty of Arts.

2. To gain the example of creating online-media lessons using cues in other subjects.

**4. Hypotheses**

1. The online-media lessons using cues on the topic “composition” gain the quality at the level of “Good”
2. The students’ posttest of learning achievement is significantly higher than the pretest at the level of .01.

**5. Population**

The population of this research was 45 first year certificate students of fine art department, faculty of Arts, Saowabha Vocational College.

**6. Sampling**

The 30 first year certificate students of fine art department, faculty of Arts, Saowabha Vocational College were simpler random sampled.

**7. Experts**

1. The 3 experts had graduated at least master degree in Art or had been taught at least 5 years about composition and they are specified sampled.
2. The 3 experts for online multi-media had graduated in educational technology or had been taught about computer assisted instruction; CAI, at least 5 years and they are specified sampled.

**8. Production process of online multi-media using cues**

The production process of online multi-media using cues on the topic “composition” are as follows [4]

Step1. Analysis

Do a brain storm chart to make a concept chart and create the content network chart.

Step2. Design

Design the lesson by identify the components of the lesson includes introduction, pretest, delivering the content using cues, summarization, and posttest. After that do the strategic presentation plan and

identify the behavioral objectives of any unit and finally, make a module presentation chart.

Step3. Development

Develop the script of the lesson with still picture, animation, sound and video. After that develop the storyboard and inspected by the content experts.

Step4. Implementation

The researcher used Adobe Dreamweaver program for the online multi-media lessons production and management. The others supporting programs are Adobe Photoshop, Adobe Flash.

Step5. Evaluation

The lessons’ quality was evaluated by the content and online multi-media experts.

**9. Research procedure**

This research used randomized one-group pretest-posttest design [5]

Randomization	Pretest	Treatment	Posttest
R	T1	X	T2

- The symbol meaning
- R = Sample randomization
  - X = Treatment by online multi-media
  - T1 = Pretest
  - T2 = Posttest

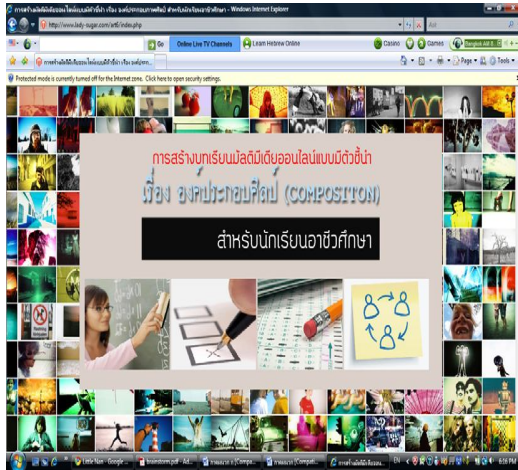
**10. Results**

**1. Online multi-media lesson using cues**

The online multi-media lesson using cues on the topic “Composition” delivered the content in form of sounds, graphics, and illustrations. The online learning of lessons used cues to stimulate the students and increase the desired responses. Cues used in the lessons are bold letters, changing the colors of letters, and color strips.

**Examples of lessons**

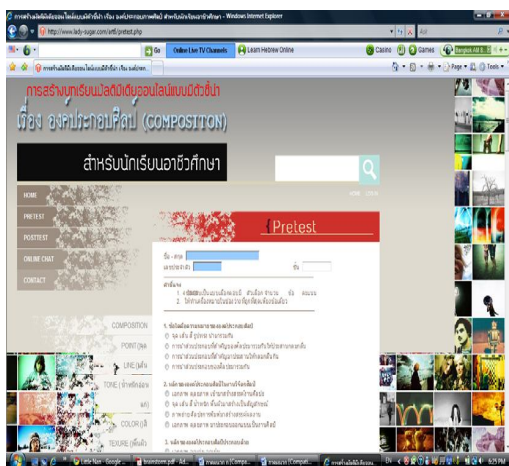
bold letters, and color strip



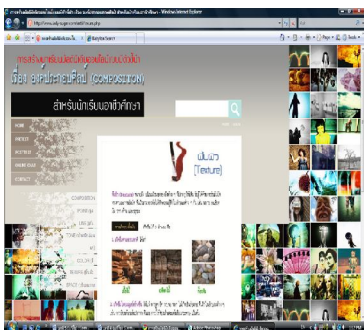
**Fig. 1** Home page screen.



**Fig. 4** Using cues by changing letters' colors and using color strips



**Fig. 2** Pretest Page



**Fig. 3** Using the change of letters' colors,

**2. The quality of online multi-media evaluation**

**2. 1The content quality evaluation of online multi-media using cues**

Evaluation	topics	S.D.
$\bar{X}$		
Content Objectives	4.67	0.33
Cuing by pictures, languages, and letters	4.44	0.51
Test / Evaluation	4.11	0.19
Average	4.39	0.34

From table, the 3 experts evaluated the content quality of online multi-media using cues. The average of the evaluation was at 4.39 and the standard deviation was 0.34 that referred to the content quality was at the level of "Good".

**2. 2 The lesson construction quality evaluation of online multi-media using cues**

Evaluation	topics	S.D.
$\bar{X}$		
Letters	4.47	0.12
Still pictures	4.83	0.29
Cuing interaction	4.92	0.14
Average	4.74	0.18

From table, the 3 experts evaluated the lesson construction quality of online multi-media using cues. The average of the evaluation was at 4.74 and the standard deviation was 0.18 that referred to the content quality was at the level of “Very good”.

### 3. The learning achievement

Testing	n	$\bar{X}$	S.D.	$\Sigma D$	$\Sigma D^2$	t
Pre-test	30	12.67	3.20	343	17649	17.99**
Post-test	30	24.10	2.45			

\*\* With statistical significance at the .01 level

From table, the pretest learning achievement was significantly higher than posttest learning achievement at the level of .01.

### 4 .Satisfaction evaluation

Evaluation topics	$\bar{X}$	S.D.
Program	4.42	0.50
Content	4.49	0.50
Pictures and letters	4.50	0.50
Cuing for instruction	4.48	0.50
Average	4.47	0.50

### 11 .Discussion

The research findings that the content quality of online multi-media using cues was at the level of “Good” and the lesson construction quality of online multi-media using cues was at the level of “Very good”. The online multi-media had been systematically produced with five steps of instructional design. The students also had significantly higher posttest learning achievement than pretest at the level of .01. This might because of the application of using cues in the online multi-media lessons that stimulate the students to fast understand the content and made it easy to learn. In addition, the cues can also be interacted with the students. For the satisfaction of the students toward of online multi-media using cues that was at the level of “Very good”, this might because of the simple form and clearness of letters used in the lessons and

the pictures used were interesting. The production of online multi-media using cues focused on the students’ individualization. In conclusion, the online multi-media using cues can be used in the instruction.

### 12. References

- [1] Supachai Sukhanin, 2009, **Open the world of e-Learning via internet, SE-EDUCATION**, Bangkok.
- [2] Kunyarat Sriwatcharakul, 2002, **Effectiveness of using cues in computer assisted instruction toward the Thai learning achievement**, Faculty of Education, Department of Educational Technology, Khonkaen University.
- [3] Chalude Nimsamuer, 2005, **Composition**, Thai Watanapanich, Bangkok.
- [4] Pairote Teeronthanakul, et al, 1998, **Creating IMMCAI Package**, Faculty of Industrial Education, University of Technology Thonburi.
- [5] Luan Saiyot and Angka Saiyot, 2006, **Behavioral and Sociological Research Methodology**. 7 edition, Suviriyasarn, Bangkok.

## **E-Book Entitled “Inside KMUTT” for Public Relations and News about King Mongkut’s University of Technology Thonburi through Online Social Network**

Pornpapatsorn Princhankol, Patitta Tunyanitikul and Wipawan Rungruangviriyaya

*Department of Educational Communication and Technology*

*Faculty of Industrial Education and Technology*

*King Mongkut's University of Technology Thonburi*

[pornpapatsorn.pri@kmutt.ac.th](mailto:pornpapatsorn.pri@kmutt.ac.th) [mod\\_friendship@hotmail.com](mailto:mod_friendship@hotmail.com) , [kuk\\_k@hotmail.com](mailto:kuk_k@hotmail.com)

### **Abstract**

*This research was aimed to publish a series of E-Book entitled “Inside KMUTT” for public relations and news about King Mongkut’s University of Technology Thonburi through online social network. The quality of the E-Book was assessed by the panel of 3 experts in contents and 3 experts in media production. The satisfaction of the sampling group towards the E-Book was also measured. The tool used in this research consisted of the E-Book, the quality assessment form for the contents and the media production of the E-Book, and the satisfaction questionnaire for the sampling group. The research results showed that the quality of the developed E-Book was assessed by the experts in contents to be 4.47 on average with standard deviation of 0.42, or at good level. The quality in terms of media was 4.54 on average with standard deviation of 0.09, or at very good level. The satisfaction of the sampling group towards the E-Book was 4.62 on average with standard deviation of 0.13, or at the highest level. Therefore, the publication of E-Book entitled “Inside KMUTT” for public relations and news about King Mongkut’s University of Technology Thonburi could be used for public relations and news distribution with the target group.*

### **1. Background and significance**

King Mongkut’s University of Technology Thonburi (KMUTT) is an educational institution with the focus on public relations and news about the university and as such supports the publication of “Inside KMUTT Newsletter” or a monthly university newspaper, organized by the Department of Public Relations, King Mongkut’s University of Technology Thonburi to distribute the news and activities within the university.

The publication of an E-Book version is one approach to gathering information and boosting public relations about the university with the

students, the staff members and the general public who are interested in King Mongkut’s University of Technology Thonburi. To publish an E-Book version is considered to be a new format because this version would be created using computer software to become a file or a folder so that the E-Book could be read on the screen both offline and online. The features of E-Book are that each section could be linked and that there can be an interaction between the reader and the book. Moreover, the E-Book version can contain images, audio clips and animations. They can also be printed and be updated all the time to catch up with the latest information. These features are not available in the normal paper format.

Therefore, the research team would like to conduct a study into the approach to the E-Book entitled “Inside KMUTT” for public relations and news about King Mongkut’s University of Technology Thonburi through online social network so that the readers—students, staff members and the general public—can read the information from King Mongkut’s University of Technology Thonburi in a new, accessible format. Moreover, the information and the contents from “Inside KMUTT Newsletter” will be updated with a new layout and color schemes to gain more interest from the readers about the publication of the electronic version or the E-Book entitled “Inside KMUTT” [1].

### **2. Research objectives**

1. To publish the E-Book entitled “Inside KMUTT” for public relations and news about King Mongkut’s University of Technology Thonburi through online social network.

2. To examine the quality of the E-Book entitled “Inside KMUTT” for public relations and news about King Mongkut’s University of Technology Thonburi through online social network.

3. To examine the readers’ satisfaction towards the E-Book entitled “Inside KMUTT” for public relations and news about King Mongkut’s University



of Technology Thonburi through online social network.

### 3. Expected outcomes

1. There will be a series of the E-Book entitled “Inside KMUTT” for public relations and news about King Mongkut’s University of Technology Thonburi through online social network and this will boost up the image of the organization.

2. This publication of the E-Book entitled “Inside KMUTT” for public relations and news about King Mongkut’s University of Technology Thonburi through online social network will become a new channel for distributing the information to the target group.

3. There will be lessons learnt for the approach to improving the E-Book entitled “Inside KMUTT” for public relations and news about King Mongkut’s University of Technology Thonburi through online social network.

### 4. Research hypotheses

1. The quality of the E-Book entitled “Inside KMUTT” for public relations and news about King Mongkut’s University of Technology Thonburi through online social network would be at good level.

2. The readers’ satisfaction towards the E-Book entitled “Inside KMUTT” for public relations and news about King Mongkut’s University of Technology Thonburi through online social network would be at high level.

### 5. Research scope

The research scope of this research into the E-Book entitled “Inside KMUTT” for public relations and news about King Mongkut’s University of Technology Thonburi through online social network was as follows:

#### 5.1. Population

The population in this study consisted of the general public who are interested in the E-Book entitled “Inside KMUTT” for public relations and news about King Mongkut’s University of Technology Thonburi through online social network.

#### 5.2. Sampling group

The sampling group in this study consisted of 30 students from the Department of Educational Communication and Technology, Faculty of Industrial Education and Technology, King Mongkut’s University of Technology Thonburi who were chosen using purposive sampling method because they were interested in the E-Book entitled “Inside KMUTT”.

#### 5.3. Expert panel

The expert panel in this research was those who have knowledge and skills and they will assess the quality of the E-Book entitled “Inside KMUTT” for public relations and news about King Mongkut’s University of Technology Thonburi through online social network. They were chosen using purposive sampling method and there were two areas of expertise.

**5.3.1. Experts in the media production.** The experts in the media production are those with at least a Master’s degree or at least 5 years of working experience. They have knowledge, experiences and skills in the media production or the publication of electronic books. Three experts would assess the quality of the E-Book entitled “Inside KMUTT” in terms of media production.

**5.3.2. Experts in the contents.** The experts in the contents are those with at least a Master’s degree who understand the language styles and the contents. They must have at least 5 years of working experience with language to assess the quality of the E-Book entitled “Inside KMUTT” in terms of contents.

#### 5.4. Scope of contents

The E-Book entitled “Inside KMUTT” for public relations and news about King Mongkut’s University of Technology Thonburi through online social network would contain the information about the university as well as the articles about trivia, knowledge, entertainment and technology.

#### 5.5. Variables in this study

Independent variable in this study was the E-Book entitled “Inside KMUTT” for public relations and news about King Mongkut’s University of Technology Thonburi through online social network.

Dependent variables in this study were as follows:

1. The quality of the E-Book entitled “Inside KMUTT” for public relations and news about King Mongkut’s University of Technology Thonburi through online social network.

2. The readers’ satisfaction towards the E-Book entitled “Inside KMUTT” for public relations and news about King Mongkut’s University of Technology Thonburi through online social network.

## 6. Tools used in this research

The tools in this research were developed by the researchers. These are:

1. The E-Book entitled “Inside KMUTT” for public relations and news about King Mongkut’s University of Technology Thonburi through online social network.

2. The quality assessment form for the E-Book entitled “Inside KMUTT” for public relations and news about King Mongkut’s University of Technology Thonburi through online social network.

3. The satisfaction questionnaire intended for the readers who have read the E-Book entitled “Inside KMUTT” for public relations and news about King Mongkut’s University of Technology Thonburi through online social network.

## 7. Procedure for tool development

The tools in this research consisted of the E-Book entitled “Inside KMUTT” for public relations and news about King Mongkut’s University of Technology Thonburi through online social network, the quality assessment form for the panel of experts in contents and media production, and the satisfaction questionnaire for the sampling group. Each tool was developed according to the ADDIE principle [2]. ADDIE is the procedure for instructional system design and in this ADDIE Model, there are the following stages: Analysis, Design, Development, Implementation and Evaluation.

### 7.1. Publishing the E-Book

Publishing the E-Book entitled “Inside KMUTT” for public relations and news about King Mongkut’s University of Technology Thonburi through online social network according to the ADDIE Principle.

**7.1.1. Analysis.** The analysis stage began with the preparation of all contents so that the scope of the E-Book could be delimited for the suitability about the contents regarding the university. This first stage of

the ADDIE model was aimed at analysing the project and followed these steps:

1. The project was examined and the contents were analyzing before the E-Book development.

2. The sampling group was examined for the analysis. In this project, the sampling group consisted of 30 people who were interested in the E-Book entitled “Inside KMUTT” for public relations and news about King Mongkut’s University of Technology Thonburi through online social network. They were chosen using purposive sampling method.

3. The objectives of the tools were defined. In this study, the objectives were given below:

3.1. To publish the E-Book entitled “Inside KMUTT” for public relations and news about King Mongkut’s University of Technology Thonburi through online social network.

3.2. To examine the quality of the E-Book entitled “Inside KMUTT” for public relations and news about King Mongkut’s University of Technology Thonburi through online social network.

3.3. To measure the readers’ satisfaction towards the E-Book entitled “Inside KMUTT” for public relations and news about King Mongkut’s University of Technology Thonburi through online social network.

**7.1.2. Design.** The data and the related literature were gathered for the publication of the E-Book entitled “Inside KMUTT” for public relations and news about King Mongkut’s University of Technology Thonburi through online social network. The documents containing the data about the university were verified for the accuracy and the contents were rewritten for clarity. Brain storm chart was drawn to analyze the contents. The data were gathered from many different sources to be added in the E-Book.

Content Network chart was drawn to analyze the structure of the contents. These contents were rearranged according to the readability and the sequence of the contents. The content network chart was drawn for each page of the E-Book in order to gain attention from the readers. The contents on each page as well as the page layout would be read and approved by the supervisors in order to make them eye-catching and interesting.

**7.1.3. Development.** All the contents were prepared and then they were placed in the publishing software in order to publish the E-Book entitled “Inside KMUTT” for public relations and news about King Mongkut’s University of Technology Thonburi



through online social network. The software was efficient and could handle many different tasks. Afterwards, the software converted the file into the electronic book format. The supervisors would then check the accuracy of the E-Book entitled “Inside KMUTT” for public relations and news about King Mongkut’s University of Technology Thonburi through online social network. For many times, the E-Book was revised, either by adding more contents or changing the contents, to suit the scope of contents.

**7.1.4. Evaluation.** The expert panel evaluated the E-Book entitled “Inside KMUTT” for public relations and news about King Mongkut’s University of Technology Thonburi through online social network in order to improve the quality of the E-Book. Certain areas were revised according to the panel’s comments.

**8. Data collection**

To obtain the data for this research, the following steps had been done.

1. The panel of experts in media production and contents were the first to use this E-Book and then they assessed the quality of the E-Book entitled “Inside KMUTT” for public relations and news about King Mongkut’s University of Technology Thonburi through online social network.

2. The readers were given the E-Book and then they expressed their satisfaction towards the E-Book entitled “Inside KMUTT” for public relations and news about King Mongkut’s University of Technology Thonburi through online social network.

3. The data collected from the panel of experts in contents and media production as well as the one collected from the sampling group were gathered to calculate the mean score and to test out the hypotheses. Then the results were reported according to the statistical finding.

**9. Research results**

**9.1. The publication of the E-Book**

The publication of the E-Book entitled “Inside KMUTT” for public relations and news about King Mongkut’s University of Technology Thonburi through online social network could be shown in Figures 1 and 2.



Figure 1. Shows the E-Book entitled “Inside KMUTT”



Figure 2. Shows the E-Book presentation format (www.prkmutt.ac.th)

**9.2. The results from this research into the E-Book**

The results from this research into the E-Book entitled “Inside KMUTT” for public relations and news about King Mongkut’s University of Technology Thonburi through online social network could be grouped into 3 aspects:

**9.2.1. The quality of the E-Book by experts in content.** The quality of the E-Book entitled “Inside KMUTT” for public relations and news about King Mongkut’s University of Technology Thonburi through online social network as assessed by the panel of three experts in contents.

Table 1. Shows the quality assessment in terms of contents.

Item	Analysis Result		
	$\bar{x}$	S .D.	Evaluation
1. Contents	4 .33	0 .57	Good
2. Images, texts and language	4 .50	0 .52	Good
3. Distribution on online social network	4 .58	0 .57	Very Good
Mean	4 .47	0 .42	Good

According to Table 1, the quality of the E-Book entitled “Inside KMUTT” for public relations and news about King Mongkut’s University of Technology Thonburi through online social network in terms of contents was 4.47 on average with standard deviation of 0.42. When the value was interpreted according to the criteria, the quality of the E-Book entitled “Inside KMUTT” for public relations and news about King Mongkut’s University of Technology Thonburi through online social network was at good level.

**9.2.2. The quality of the E-Book by experts in media production.** The quality of the E-Book entitled “Inside KMUTT” for public relations and news about King Mongkut’s University of Technology Thonburi through online social network as assessed by the panel of three experts in media production.

Table 2. Shows the quality assessment in terms of media production.

Item	Analysis Result		
	$\bar{x}$	S .D.	Evaluation
1. Design	4 .41	0 .62	Good
2. Letters and captions	4 .50	0 .57	Good
3. Media and technique	4 .50	0 .38	Good
4. The format of the E-Book for online social network	4 .50	0 .25	Good
Mean	4 .54	0 .09	Very Good

According to Table 2, the quality of the E-Book entitled “Inside KMUTT” for public relations and news about King Mongkut’s University of Technology Thonburi through online social network in terms of media production was 4.54 on average with standard deviation of 0.09. When the value was interpreted according to the criteria, the quality of the E-Book entitled “Inside KMUTT” for public relations and news about King Mongkut’s University of Technology Thonburi through online social network was at very good level.

**9.2.3. The satisfaction towards the E-Book by sampling group.** The satisfaction towards the E-Book entitled “Inside KMUTT” for public relations and news about King Mongkut’s University of Technology Thonburi through online social network as expressed by the sampling group of 30 persons chosen using purposive sampling method.

Table 3. Shows the satisfaction level of the sampling group.

Item	Analysis Result		
	$\bar{x}$	S .D.	Evaluation
1. Contents	4 .57	0 .53	The Highest
2. Images, texts and language	4 .57	0 .54	The Highest
3. Distribution on online social network	4 .66	0 .53	The Highest
4. The format of the E-Book for online social network	4 .68	0 .54	The Highest
Mean	4 .62	0 .13	The Highest

According to Table 3, the sampling group’s satisfaction towards the E-Book entitled “Inside KMUTT” for public relations and news about King Mongkut’s University of Technology Thonburi through online social network was 4.62 on average with standard deviation of 0.13. When the value was interpreted according to the criteria, the sampling group’s satisfaction towards the E-Book entitled “Inside KMUTT” for public relations and news about King Mongkut’s University of Technology Thonburi through online social network was at the highest level.

## 10. Discussion

According to the research into the E-Book entitled “Inside KMUTT” for public relations and news about King Mongkut’s University of Technology Thonburi through online social network, the results could be discussed as follows:

In terms of contents, the E-Book entitled “Inside KMUTT” for public relations and news about King Mongkut’s University of Technology Thonburi through online social network was evaluated according to the topic about contents, images, texts, language, and distribution on online social network. The E-Book was verified for accuracy by the experts. The overall mean score was 4.47 or at good level because the E-Book entitled “Inside KMUTT” for public relations and news about King Mongkut’s University of Technology Thonburi through online social network was accurate and suitable for distribution on online social network. This finding is similar to the one found in the research by Kanya Chaisingha, Suphara Sada and Akkarapol Tongyao [3] who conducted a study into “the production and the presentation of educational materials for undergraduate students at Naresuan University” and found that the quality of the contents was at good level.

In terms of media production, the E-Book entitled “Inside KMUTT” for public relations and news about King Mongkut’s University of Technology Thonburi through online social network was designed and developed according to the ADDIE Model [2] which comprises of analysis, design, development, implementation and evaluation. The results from the quality assessment in terms of media production showed that the quality of the E-Book was 4.54 on average or at very good level. This is because the E-Book entitled “Inside KMUTT” for public relations and news about King Mongkut’s University of Technology Thonburi through online social network was accurate and suitable for distribution on online social network. This finding complies with the research by Akkaradet Simaneepan [4] who conducted a study into the E-Book with multimedia entitled “Using instructional media for the staff personnel at Dhurakij Pundit University” and found that the quality of the E-Book with multimedia as instructional media was at very good level.

As for the satisfaction of the sampling group towards the E-Book entitled “Inside KMUTT” for public relations and news about King Mongkut’s University of Technology Thonburi through online social network, it was 4.62 on average. When the

value was interpreted according to the criteria, it was found that their satisfaction was at the highest level. The E-Book could be used to distribute the information in an accessible manner to the users as Yuen Phusuwan [5] says that learners could use the links and many folders in the E-Book to search the internet for more information. Therefore, E-Books should be seen as educational media which can contain data in many formats such as texts, still images, animations and sounds so that readers can search quickly. They are effective and can be used at any time and any place. This is similar to the research by Chareeporn Phuma [6] who conducted a study into the expectations and the satisfaction towards the use of computer network in Thai school (or School Net) to develop the education and the learning of secondary school students in Bangkok. Her results showed that the students’ satisfaction was at the highest level. Similarly, Chittima Phuttacharoen [7] conducted a study into the learning achievement and the satisfaction towards webpages with different layouts and found that the students’ satisfaction was at the highest level.

## 11. Suggestions

### 11.1. Suggestions for application

1. The users of the E-Book entitled “Inside KMUTT” for public relations and news about King Mongkut’s University of Technology Thonburi through online social network could use the E-Book as a resource tool for the information about the university.

2. The users of the E-Book entitled “Inside KMUTT” for public relations and news about King Mongkut’s University of Technology Thonburi through online social network could use the E-Book to distribute their study and to adopt the approach to the publication of the E-Book.

### 11.2. Suggestions for further research

1. The E-Book entitled “Inside KMUTT” for public relations and news about King Mongkut’s University of Technology Thonburi through online social network should be developed as an application for iOS or Android system as another channel for accessibility.

2. The E-Book entitled “Inside KMUTT” for public relations and news about King Mongkut’s University of Technology Thonburi through online

social network should be developed with more interaction with the users.

## 12. Acknowledgements

The researchers would like to express their gratitude to all previous teachers who kindly transfer their knowledge and experiences. We also would like to thank the Department of Public Relations, KMUTT for the information as well as all the persons who are not mentioned here but have helped us considerably. We also thanked our parents for their support. The researchers really hope that this research is helpful and beneficial to those who are interested and those would like to adopt the approach to publishing other electronic books for public relations.

## 13. References

[1] Suthichai Panyaroj, *Public Relations*, [online], Available: <http://www.bloggang.com/viewdiary> [23 September, 2011].

[2] *ADDIE Model*, [online], Available: <http://www.kroobannok.com/5661> [5 May, 2011].

[3] Kanya Chaisingha, Suphara Sada and Akkarapol Tongyao, 2006, *The Development of Electronic Book Entitled "The Production and the Presentation of Educational Materials for Undergraduate Students at Naresuan University"*, Master's thesis in Education (Educational Communication and Technology), Naresuan University.

[4] Akkaradet Simaneepan, 2004, *The Development of Electronic Book with Multimedia for Training Entitled "Using Instructional Media for the Staff Personnel at Dhurakij Pundit University"*, a Master's thesis in Education, Faculty of Education, Dhurakij Pundit University.

[5] Yuen Phusuwan, 1995, *Internet for Beginners*, SE-EDUCATION, Bangkok.

[6] Chareeporn Phuma, 2000, *The Expectations and the Satisfaction towards the Use of Computer Network in Thai School (or School Net) to Develop the Education and the Learning of Secondary School Students in Bangkok*, a Master's thesis in Journalism, Faculty of Journalism and Mass Media, Thammasat University.

[7] Chittima Phuttacharoen, 2000, *The Learning Achievement and the Satisfaction towards the Webpages with Different Layouts*, a Master's thesis in Education, Faculty of Education, Kasetsart University.

## **Psychology**

# Underestimation of body weight among students of medicine and allied health sciences of public sector institutes in Karachi, Pakistan

Sajid Mahmood, Jenny Freeman, Clare Relton  
School of Health and Related Research (ScHARR), University of Sheffield, UK  
[sajid.mahmood@sheffield.ac.uk](mailto:sajid.mahmood@sheffield.ac.uk)

## Abstract

*Objectives:* To determine the prevalence of underestimation of body weight and identify high risk groups in tomorrow's health professionals.

*Methodology:* A cross-sectional analytical study was conducted [March to December 2012] in six different institutes in Karachi, Pakistan. Data were collected from undergraduate students of medicine, dentistry, physiotherapy, pharmacy and nursing through self-administered questionnaires, followed by anthropometric measurements. Actual weight categories were defined by using South Asian cut-off points for body mass index (BMI). Underestimation of body weight occurred if participants self-reported a lower weight category than their independently measured weight category. Ethical approval was obtained from the University of Sheffield, UK and Dow University of Health Sciences, Pakistan. Logistic regression was used to determine the factors associated with underestimation of body weight.

*Results:* Of 2114 participating students, 28.1% underestimated their body weight. Men were more likely to underestimate their body weight compared to women [OR=3.45 (95%CI: 2.54-4.67)], and compared to normal weight individuals, overweight and obese individuals were more likely to underestimate weight [OR=13.09 (95%CI: 10.10-16.96)]. Compared to self measured weight, participants who relied on other people for their weight category were more likely to underestimate it than those who decided for themselves [OR=1.38 (95%CI: 1.03-1.86)]. In particular, underestimation was more likely for participants who received weight-related comments from parents [OR=1.83 (95%CI: 1.38-2.42)], whereas underestimation was less likely for participants who had received weight-related comments from siblings [OR=0.71 (95% C.I: 0.54-0.95)]. However, participants with more sisters were more likely to underestimate their body weight [OR=1.13 (95% C.I: 1.04 - 1.24)].

*Conclusion:* Underestimation of body weight is highly prevalent among undergraduate students of medicine and allied health sciences in Karachi.

## 1. Introduction

### 1.1 Background

Overweight and obesity has been recognized as a public health problem worldwide due to the fact that it increases the risk of chronic diseases such as cardiovascular disease (CVD), stroke, diabetes, sleep apnoea, osteoarthritis, and many types of cancer [1-4]. It has also been said it decreases the productivity of a country by reducing life expectancy of individuals [5]. It is predicted that the prevalence of overweight and obesity will rise and by 2015 there will be approximately 2.3 billion overweight and more than 700 million obese individuals worldwide [6].

Previously, obesity was viewed as a problem of developed countries, but in the last few decades its rising trends have also been observed in developing countries [7-10]. In addition to the changes in rates in the general population, there is evidence that the prevalence of overweight and obesity is increasing at an even faster rate among medical professionals [11-18]. In Pakistan, the overall prevalence of overweight and obesity was found to be 25% in the general population [10]. As far as health professionals are concerned, study conducted in tertiary care hospital of a public sector institute found 59.2% postgraduate trainee doctors having weight more than normal (BMI  $\geq$ 23) [12]. Studies conducted among undergraduate medical students of Pakistan showed that more than a quarter were overweight and obese [13, 19, 20].

Self awareness of weight status has been shown to play important role in maintenance of a healthy weight [21]. For overweight and obese people who do not consider themselves as overweight or obese, interventions directed towards them may not be effective [22]. It has been observed in large population based studies that underestimation of body weight is common among overweight and obese people [23-25]. Study from US who found a strong association of perception of being overweight and weight loss attempts emphasized the importance of

providing awareness to overweight and obese people about their weight status in obesity related intervention programs [26].

Undergraduate students of medicine and allied health sciences are tomorrow's health professionals and as such are important role model for the general population to be followed in terms of healthy weight [12, 13]. No studies have been conducted to date on weight perception among health professionals in Pakistan. It is essential to explore the problem of underestimation of body weight among tomorrow's health professionals and to identify factors which affect their awareness about body weight. This information can then be used to tailor effective interventions designed to tackle the growing burden of overweight and obesity among this key group of professionals. More importantly with a healthy body weight, they should be better able to educate their patients regarding healthy diet and life style.

## 1.2 Objectives

The objective of the study was to determine the prevalence of underestimation of body weight and its associated factors among undergraduate students of medicine and allied health sciences in Pakistan.

## 2. Methods

### 2.1 Setting and sampling

A cross sectional analytical study was conducted in six different public sector institutes of Karachi, Pakistan. The study population consisted of undergraduate students of medicine, dentistry, physiotherapy, pharmacy and nursing. Self administered questionnaires were used to collect data from participants through census sampling technique from March to December 2012.

Ethical approval was obtained from the University of Sheffield, UK and Dow University of Health Sciences, Pakistan and permission for data collection was obtained from the head of each institute. Students were invited to participate through classroom announcements and notices placed on the main notice board of each institute. The objectives of the study were explained to participants verbally during the classroom announcements. Information was also provided on the consent form detailing the aims of the study, methods, voluntary participation, the potential benefits, and the right to refuse answering any question which they do not want.

The questionnaires were anonymous so it was not possible to link the information provided by participant data retrospectively. The collected questionnaires were kept confidential in a secure storage and only the principal investigator had access. Data were entered into a database by two independent data entry operators to minimize margin of entry error.

### 2.2 Sample size

The sample size was calculated for measuring the prevalence of underestimation of body weight among students. At 5% level of significance, with 5% bound on error of estimation and using reported range from 11.90% to 42.74% [23, 27-31] for prevalence of underestimation of body weight, the sample size calculated to be 376 by using software Epi-Info. It was multiplied with 2 for design effects as the sampling technique (census) was not based on simple random sampling in this study. Hence, a minimum of 752 completed questionnaires were required to meet objectives of the study.

### 2.2 Instrument

In light of previous studies, experts' opinion and FGDs, an initial questionnaire was developed in English. This questionnaire was piloted on group of students before the start of the main data collection to evaluate the language, content and the structure of questionnaire.

### 2.3 Procedure

After obtaining permission from the head of each academic institute for data collection, invitation letters requesting participants were placed on notice boards. The principal investigator also made classroom announcements where the objectives of the study were explained and students were asked to participate. Students who agreed to participate were instructed to pick questionnaires from research officers and to return it in two weeks time. Classroom reminders were made after this time period. After completion of questionnaires, height, weight, waist circumference and hip circumference of the participants was measured by research officers in a confidential manner.

### 2.4 Dependent variable

The dependant variable in the study was “underestimation of body weight”. It was assessed by comparing self reported weight categories of participants (underweight, normal weight, overweight, obese) on questionnaires with their actual body mass index (BMI) categories created using their measured height and weight. The recommended South Asian (SA) body mass index (BMI) cut-off points were used for this purpose [32]. Underestimation of body weight occurred if participants self-reported a lower weight category than their independently measured weight category.

### **2.5 Independent variables**

Participant’s personal characteristics: This consisted of age, sex, academic year, degree program.

Participant’s family characteristics: This consisted of family set up, number of family members, number of brother and sisters, birth order, parent’s education and occupation etc.

Participant’s weight related information: Participants were asked about their weight categories and source of their weight knowledge. They were also asked about their BMI and time since they measured their weight and BMI.

Participant’s bodyweight and people around them: Participants were asked whether they were subject to weight related comments from parents, siblings, friends or colleagues.

Participant’s opinion about external influences on their self perception of weight were explored, in terms of the role of parents, siblings, friends or colleagues on their self perception of body weight.

Participant’s opinion about acting as a role model as health professionals. They were asked if they think with healthy body weight they would be role model for general population to be followed for healthy life style. Secondly, participants were also asked if they think with healthy weight, their health education would be more effective for patients.

Anthropometric measurement: It consisted of height, weight, waist circumference and hip circumference.

### **2.6 Statistical analysis**

Data were analyzed by using Statistical Software for Social Sciences (SPSS) version 18. In descriptive analysis, mean and standard deviation was reported for continuous variables and numbers and percentages were reported for categorical variables. According to South Asian BMI cut-off points a

person was labeled as underweight if BMI was  $<18.5$ , normal weight if BMI was between 18.5 to 22.99, overweight if BMI was between 23 to 24.99 and obese if BMI was  $\geq 25$ . The reason for using lower BMI cut-off points for SA population is the higher risk associated with diabetes and cardiovascular diseases among this population even at lower level of BMI as compared to white population [33-35].

For model building, underestimation of weight was considered as the dependent variable, and its association with independent variables was explored by using simple logistic regression. The findings are reported in the form of crude odds ratios (OR) with 95% confidence intervals (CI). The significant variables were checked for multicollinearity. Thereafter, the final model was built by using enter method on multivariate logistic regression and results are reported in the form of adjusted odds ratios (AOR) with 95% CI.

### **3. Result**

A total of 4,785 students in six different institutes were approached and invited for participation, of whom 2500 students showed interest and picked up questionnaires and 2,114 of which were returned, giving an overall response rate of just below 45% (2114/4785). Similarly, there was an excellent return rate of 84.6% (2114/2500).

Approximately 12.6% of the participants were overweight and 17% were obese. The personal and socio-demographic characteristics of the participants are summarized in [Table 1].

Of the 2114 participants, 28.1% underestimated their body weight when self-reported weight category was compared with independently measured BMI category on South Asian criterion. It is important to note that underestimation of weight increases with increasing weight status [figure 1]. Among obese participants, 81.9% did not perceive themselves as obese whereas among overweight, 53.6% did not perceive themselves as overweight, and for those classifying themselves as normal, only 15.7% underestimated their weight. Overall there was poor agreement between self reported weight categories and actual BMI (Kappa = 0.344, SE = 0.015,  $p < 0.01$ ).

In the multivariate regression the factors which had a significant association with underestimation of body weight included gender, measured BMI categories, source of weight knowledge, weight related comments from parents, weight-related comments from siblings, and number of sisters. The



independent variables which were found to be not significant were assessed for confounding effects before removing from the final model. None of the variables acted as a confounder. [Table 2] shows the magnitude of association for the significant variables in the form of adjusted odds ratio along with 95% confidence intervals and p-value.

Men were more likely to underestimate their body weight compared to women [OR=3.45 (95%CI: 2.54-4.67)]. Similarly, the measured BMI categories of participants were significantly associated with underestimation of body weight (p-value <0.001); compared to normal weight individuals, overweight and obese individuals were significantly more likely to underestimate weight [OR=13.09 (95%CI: 10.10-16.96)].

Compared to self measured weight, participants who relied on other people for their weight category were more likely to underestimate weight than those who decided for themselves [OR=1.38 (95%CI: 1.03-1.86)]. Odds of underestimation among participants who relied on other people for their weight category was 1.38 times the odds of underestimation of weight among those who self measured weight and decided for themselves.

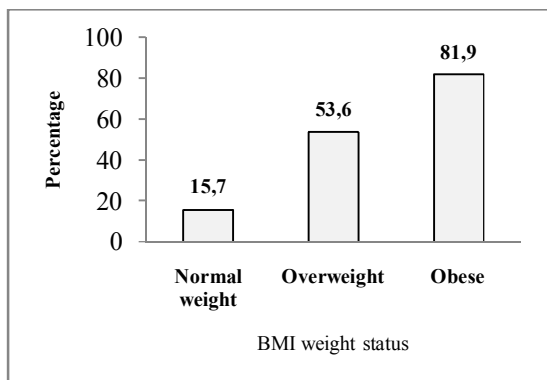
Underestimation was more likely for participants who received weight-related comments from parents [OR=1.83 (95%CI: 1.38-2.42)]. Odds of underestimation of weight for participants who had

<b>Table 1: Personal and socio-demographic characteristics of study participants</b>	
<b>Variable</b>	<b>(%) n=2114</b>
<b>Gender</b>	
Women	81.5
Men	18.5
<b>Academic degree</b>	
Medicine	49.8
Dentistry	17.1
Pharmacy	16.6
Physiotherapy	8.7
Nursing	7.8
<b>Academic year of studying</b>	
1st Year	26.9
2nd Year	22.6
3rd Year	22.1
4th Year	16.2
5th Year	12.2
<b>Family set up</b>	
Nuclear *	79.1
Extended **	20.9
<b>Birth order</b>	

Elder	33.1
Middle	43.5
Youngest	21.6
Only child	1.8
<b>Socioeconomic status (SES)</b>	
Lower SES <sup>a</sup>	6.7
Middle SES <sup>b</sup>	90.0
High SES <sup>c</sup>	3.3
<b>Knowledge of BMI</b>	
Yes	24.7
No	75.3
* live with parents and siblings	
* live with parents, siblings and grandparents, uncles, aunts or cousins	
<sup>1</sup> Underweight: BMI < 18.5; <sup>2</sup> Normal Weight: BMI 18.5 to 22.9; <sup>3</sup> Overweight: 23.0 to 24.9; <sup>4</sup> Obese: BMI: ≥ 25.0	
<sup>a</sup> High SES: Car and air conditioner;	
<sup>b</sup> Middle SES: Fridge, television, computer, washing machine± car or air conditioner	
<sup>c</sup> Low SES: Radio, telephone, cycle, motorcycle ± fridge, television, computer or washing machine	

received weight-related comments from parents was 1.83 times the odds of underestimation of weight who had not received weight related comments from parents. In contrast to this, underestimation was less likely for participants who had received weight-related comments from siblings [OR=0.71 (95% C.I: 0.54-0.95)] as odds of underestimation of weight for participants who had received weight-related comments from siblings was 0.71 times the odds of underestimation of weight who had not received comments from siblings.

Other variable which had significant association with underestimation of weight was number of sisters [OR=1.13 (95% C.I: 1.04 to 1.24)]. Odds of underestimation of weight among participants increase by 1.13 times with increase in each number of sisters.



**Figure 1: Underestimation of body weight and BMI weight status**

**Table 2: [Multivariate logistic regression model] Adjusted odd ratios of factors associated with underestimation of body weight participants (n = 2114)**

Variable	R	O	95% CI	P value
<b>Gender</b>				<0.001*
Women		1		
Men		3.45	2.54 - 4.67	
<b>BMI</b>				<0.001*
Normal weight <sup>1</sup>		1		
Overweight&Obese <sup>2</sup>		3.09	10.10-16.96	
<b>Source of weight knowledge</b>				0.038*
Self assessment		1		
Informed by someone		1.38	1.03 - 1.86	
<b>Parents commented on body weight</b>				<0.001*
No		1		
Yes		1.83	1.38 - 2.42	
<b>Siblings commented on body weight</b>				0.005*
No		1		
Yes		0.54	0.54 - 0.95	
<b>Number of sisters</b>				0.004*
1		1		
13		1.24	1.04 - 1.24	

<sup>1</sup>Normal Weight: BMI 18.5 to 22.9 \*Significant at p value ≤ 0.05 <sup>2</sup>Overweight & Obese: BMI: ≥ 23.0

#### 4. Conclusion

It can be concluded that underestimation of body weight is highly prevalent among undergraduate students of medicine and allied health sciences in Karachi. Along with routine academic curriculum, there is strong need to educate and provide awareness to students about healthy body weight and life style. This would equip them with enough knowledge to assess their weight on their own and address their weight related problem accordingly instead of acting on the basis of misperception.

Health professionals with healthy body weight would serve their patients in better way. They would be able to provide effective health education to general population which is imperative to address the issue of obesity in Pakistan.

#### 5. References

- [1] S. N. Blair, J. Shaten, K. Brownell, G. Collins, L. Lissner. "Body weight change, all cause mortality and cause specific mortality in Multiple Risk Factors Intervention Trail". *Annals of Internal Medicine* 1993; 119: 749-57.
- [2] A. Must, RS Strauss. "Risks and consequences of childhood and adolescent obesity". *International Journal of Obesity and Related Metabolic Disorders* 1999; 23(2): S2-11.
- [3] S. Kenchaiah, J. C. Evans, D. Levy, P.W. Wilson, E.J. Benjamin, et al. "Obesity and the risk factors of the heart failure". *New England Journal of Medicine* 2002; 347(5):305-13.
- [4] S.D. Malnick, H. Knobler. "The medical complications of obesity". *International Journal of Medicine* 2006; 99(9): 565-79.
- [5] D. W. Haslam, W.P. James. "Obesity". *Lancet* 2005; 366(9492): 1197-209.
- [6] R. Byington, S. Keene, D. Samples. "An Epidemiological Overview Of Pediatric Obesity: A Global Perspective Of A Growing Problem". *The Internet Journal of World Health and Societal Politics* 2009; 6(2): DOI: 10.5580/126a.
- [7] J.C. Seidell. "Time trends in obesity: an epidemiological prospective". *Hormone and metabolic research* 1997; 29(4):155-158.

- [8] D Shufa, L. Bing, Z. Fengying, M.P. Barry. "A new stage of the nutrition transition in China". *Public Health Nutrition* 2002; 5(1A): 169-174
- [9] A. Rashidy-Pour, M. Malek, R. Eskandarian, R. Ghorbani. "Obesity in the Iranian population". *Obesity Reviews* 2009; 10(1): 2-6.
- [10] T. H. Jafar, C. Nish, P. Gregory. "Prevalence of overweight and obesity and their association with hypertension and diabetes mellitus in Indo-Asian population". *Canadian Medical Association Journal* 2006; 175 (9):1071-77.
- [11] S. H. Zafar, I. Haque, A.R. Butt, H.G. Mirza, F. Shafiq. "Relationship of Body Mass Index and Waist to Hip Ratio measurement with hypertension in young adult medical students". *Pakistan Journal of Medical Sciences* 2007; 23: 574-9.
- [12] S. Mahmood, M.K. Najjad, N. Ali, N. Yousuf, Y. Hamid. "Predictors of overweight and obesity among postgraduate trainee doctors working in tertiary care hospital of public sector Karachi, Pakistan". *Journal of Pakistan Medical Association* 2010; 60:758-61.
- [13] N. Nighat, H.Q. Majid, F. Kiran, P. Shakeela. "Dietary habits and life style among the students of a private Medical University Karachi". *Journal of Pakistan Medical Association* 2009; 59(2): 98-101.
- [14] G. Bertias, I. Mammias, M. Linardakis, A. Kafatos. "Overweight and obesity in relation to cardiovascular disease risk factors among medical students in Crete, Greece". *BioMed Central Public Health* 2003; 3:3.
- [15] M. A. Sawsan, Y.M. Elsadig. "Obesity among medical students of the National Ribat University, Khartoum". *Sudanese Journal of Public Health* 2010; 2(3):16-19.
- [16] A. Z. Mohtasham, M. Maddah. "Prevalence of overweight and obesity among female medical students in Guilan-2003". *Iranian Journal of Endocrinology and Metabolism* 2006; 8(2): 157-162.
- [17] A. O. Carter, M. Elzubeir, Y. M. Abdulrazzaq, A. D. Revel, A. Townsend. "Health and lifestyles assessments of medical students in the United Arab Emirates". *Medical Teacher* 2003; 25(5): 492-96.
- [18] N. Y. Boo, G. J. Q. Chia, L. C. Wong, R. M. Chew, W. Chong. "The prevalence of obesity among clinical students in a Malaysian medical school". *Singapore Medical Journal* 2010; 51(2): 126-32.
- [19] M. R. Hingorjo, S. Syed, M. A. Qureshi. "Overweight and obesity in students of a Dental College of Karachi: lifestyle influence and measurement by an appropriate anthropometric index". *Journal of Pakistan Medical Association* 2009; 59(8): 528-32.
- [20] S. Mahmood, T. Perveen, M. Najjad, N. Yousuf, F. Ahmed, et al. "Overweight and Obesity among Medical Students of Public Sector's Institutes in Karachi, Pakistan". *J Obes Wt Loss Ther* 2013; 3:157
- [21] P. J. Elmer, E. Obarzanek, W.M. Vollmer, D. Simons-Morton, V. J. Stevens, et al. "Effects of comprehensive lifestyle modification on diet, weight, physical fitness, and blood pressure control: 18-month results of a randomized trial". *Ann Intern Med* 2006, 144:485-495.
- [22] O. J. Prochaska, C. A. Redding, K. E. Evers: The transtheoretical model and stages of change. In *Health Behavior and Health Education: Theory, Research, and Practice*. 3 edition. Edited by: Glanz K, Rimer BK, Lewis FM. San Francisco: Jossey-Bass; 2002:99-120.
- [23] F. Kuchler, J. N. Variyam. "Mistakes were made: misperception as a barrier to reducing overweight". *Int J Obes Relat Metab Disord* 2003, 27:856-861.
- [24] W. L. Johnson-Taylor, R. A. Fisher, V. S. Hubbard, P. Starke-Reed, P. S. Eggers. "The change in weight perception of weight status among the overweight: comparison of NHANES III (1988-1994) and 1999-2004 NHANES". *Int J Behav Nutr Phys Act* 2008, 5:9.
- [25] S. Ziebland, M. Thorogood, A. Fuller, J. Muir. "Desire for the body normal: body image and discrepancies between self reported and measured height and weight in a British population". *J Epidemiol Community Health* 1996, 50:105-106.
- [26] S. C. Lemon, M. C. Rosal, J. Zapka, A. Borg, V. Andersen. "Contributions of weight perceptions to weight loss attempts: differences by body mass index and gender". *Body Image* 2009, 6:90-96.

- [27] J. A. O'Dea, P. Caputi. "Association between socioeconomic status, weight, age and gender, and the body image and weight control practices of 6-19 years old children and adolescents". *Health Education Research* 2001; 16(5): 521-532.
- [28] E. Gualdi-Russo, A. Albertini, L. Argani. "Weight status and body image perception in Italian children". *Journal of Human Nutrition Diet* 2007; 21: 39-45.
- [29] M. P. Levine, L. Smolak, H. Hayden. "The relation of sociocultural factors to eating attitudes and behaviours among middle school girls". *Journal of Early Adolescence* 1994; 4: 471-90.
- [30] M. H. Thelen, J. F. Cormier. "Desire to be thinner and weight control among children and their parents". *Behaviour Therapy* 1995; 36:85-99
- [31] K. K. Oliver, M. H. Thelen. "Children's perception of peer influence on eating concerns". *Behaviour Therapy* 1996; 27:25-39.
- [32] C. Snehalatha, V. Viswanathan, A. Ramachandran. "Cut-off Values for Normal Anthropometric Variables in Asian Indian Adults". *Diabetes Care* 2003; 26: 1380-4.
- [33] M.A. Banerji, N. Faridi, R. Atluri, R. L. Chaiken, H. E. Lebovitz. "Body composition, visceral fat, leptin and insulin resistance in Asian Indian men". *Journal of Clinical Endocrinology Metabolism* 1999; 84: 137-144.
- [34] E. A. Enas, S. Yousuf, J. L. Mehta. "Prevalence of coronary artery disease in Asian Indians". *American Journal of Cardiology* 1992; 70; 945-949.
- [35] P. M. McKeigue, B. Shah, M. G. Marmott. "Relationship of central obesity and insulin resistance with high diabetes prevalence and cardiovascular risk in South Asians". *Lancet* 1991; 337: 382-386.

## The Incremental Validity of Videos as Visual Surrogates

Shu-Chun Lucy Huang, Noelle C. Chiang

*Department of Tourism, Shih Hsin University, Taiwan, ROC.*

*Department of Social Psychology, Shih Hsin University, Taiwan, ROC.*

[huangsch@cc.shu.edu.tw](mailto:huangsch@cc.shu.edu.tw)<sup>1</sup>, [noelle@cc.shu.edu.tw](mailto:noelle@cc.shu.edu.tw)<sup>2</sup>

### Abstract

*This study attempted to examine the incremental validity of videos in order to clarify the effects of motion and sound on participants' scenic evaluation and perceptual responses. In this study, four experimental conditions were created using the combination or separation of either motion or sound component in the videos. The regression results indicated that cognition and emotion variables in the first condition, containing motion and sound, explained the most variance of the participants' preference using the  $R^2$  or the adjusted  $R^2$  as a measure of explained variance. The cognition and emotion variable in the last condition, without motion and sound, explained the least variance of preference. The results showed the evidence of incremental validity for the motion and sound components in video presentations. Moreover, the incremental validity of videos for depicting static environments was better demonstrated than that of videos for portraying dynamic environments.*

### 1. Introduction

The issue of the validity of visual simulation was brought up in the 1970s [1-4]. However, it did not gain the attention of researchers until late 1990s [5-11]. As a matter of fact, researchers have recognized that people's environmental perception is a multi-modal [12-15] and an integrated perceptual system [16]. In other words, human environmental perception is a result of individual multi-sensory responses to the constantly changing world, and operated by an efficient integral scheme. The importance of a dynamic simulation of environment has been emphasized by researchers in the area of environmental perception. They were concerned that the inappropriate use of surrogates might result in misleading recommendations for environmental

planning, design, and management. Therefore, the validity of surrogates is an unavoidable issue in the use of visual media.

Nowadays the visual surrogates capable of dynamic simulation are computer animation and videos. However, virtual reality is still an expensive medium due to its investment of manpower, technology, and cost for production. Videos can represent the characteristics of motion and sound in the environments, and have a much higher technical and monetary feasibility than computer animation. Lately researchers have used videos as the surrogates in environmental perception studies. However, findings relating to the validity of videos are still very limited. According to Gibson's concept of the ecological approach [16] to perception, human perception involves the detection of large amounts of features in the environment, and is carried out through continuous and variant presentation of information and not through a process of capturing static images. Gibson [16] points out that a person's vision is in a state of continuous and dynamic change as he moves in the environment. Such changes can include optical flow, optical occlusion and disocclusion, and motion parallax. These views explain how movement strengthens the perceptual process of environment features, and it is the most crucial aspect of perceptual process. Surprisingly, although the perspective of Gibson's ecological perception provides a good theoretical ground for research on the perception of motion in environments, empirical findings about such environmental element is still very limited.

As to the information of sound, Schafer [17] points out that sound is an aesthetic element that can be perceived in many environments. Therefore, in investigating landscape perception, sound should be considered as a complementary environmental component. The findings of Anderson, Mulligan, Goodman, & Regen [18] and Carles, Barrio & Lucio [19] suggested that the consistency of sound and image had an effect on landscape evaluation. When visual experience and sound were consistent,

landscape preference was the highest, and if not, preference was the lowest. The results of Carles, Bernaldez & Lucio [20] revealed that the interaction between sound and image had a significant influence on participants' emotional evaluation, and the variance of environmental preference was mainly from the effect of sound component. The findings of Rohrmann & Bishop [21] showed that participants' cognitive and emotional evaluations were both strengthened when sound was added to computer simulated images. Therefore, the quality of sound is a critical environmental characteristic for the research on landscape perception and evaluation.

According to Hetherington [8], incremental validity is one of three validity when considers the appropriateness of visual surrogates. It refers to the minimum necessary and sufficient elements required to ensure the validity in visual presentation. In other words, if environmental surrogates possessing both information of motion and sound can more accurately reflect human environmental responses than those just holding either one element, it then indicates the adding of certain information indeed increase the surrogates' ability to represent real condition. Previous studies on the validity of dynamic visual surrogates have mainly focused the environmental information of motion and sound [22, 23, 24, 9]. The present study also uses the two elements as the environmental variables to examine the incremental validity of videos in order to clarify the effects of the motion and sound, in combined and separated conditions, on participants' scenic evaluation and perceptual responses.

## 2. Method

In this study, a 2 (motion vs. no motion) X 2(sound vs. no sound) experimental design was used to create 4 conditions. That is, one condition consists of both the motion and sound components and therefore is the regular video condition whereas another condition consists of none of the motion and sound components and therefore was the condition of static pictures. The other two video conditions have either the motion or the sound components in the videos. The experiment was conducted in a lab setting and in small groups (15 persons or fewer). The researcher was available on the site to provide direction and assistance throughout the experimental process. The participants were recruited from Shih Hsin University, located in Taipei, Taiwan. They were randomly assigned to one of the condition. In this study, the visual surrogates are videos. A high-

resolution and stabilized digital video camera was used to record static environments, a playground and woods, and dynamic environments, a natural river and a built water jets (Figure 1). The total length of the videos for each setting was about 1 minute. The questionnaire included five parts. They are participants' personal information, as well as participants' cognitive, emotional, behavioral, and preference assessment of the river landscape. Five-point Likert scales were used for measurement.

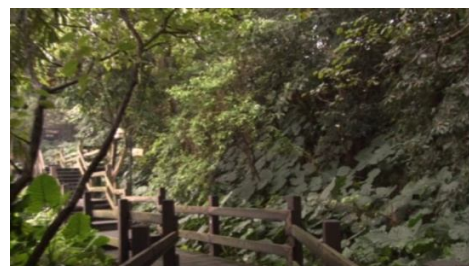


Figure 1. Four evaluated environments

### 3. Results

#### (1) The adjusted R<sup>2</sup> measures in 4 different experimental conditions

To analyze the results, the items that measure the variables of cognition and emotion were first averaged across items. Then both the cognition and emotion variables were used to predict participants' the participants' preference using the R<sup>2</sup> or the adjusted R<sup>2</sup> as a measure of explained variances (see Table 1) whereas cognition and emotion variables in the video condition that contained neither motion nor sound components explained the least variance of preference. It was also found that cognition and emotion variables in the video condition that contained only the motion component explained the second highest variances of preference and they explained the third highest variances of preference in the video condition that contained only the sound component. Therefore, the regression results showed the evidence of incremental validity for the motion and sound components in the video presentations. preferences for the two types of environments, static and dynamic environments, in 4 different experimental conditions. The regression results in the 4 conditions indicated that for both types of the environments, cognition and emotion variables in the video condition that contained both motion and sound components explained the most variance of the participants' preference using the R<sup>2</sup> or the adjusted R<sup>2</sup> as a measure of explained variances (see Table 1) whereas cognition and emotion variables in the video condition that contained neither motion nor sound components explained the least variance of preference. It was also found that cognition and emotion variables in the video condition that contained only the motion component explained the second highest variances of preference and they explained the third highest variances of preference in the video condition that contained only the sound component. Therefore, the regression results showed the evidence of incremental validity for the motion and sound components in the video presentations.

#### (2) The hierarchical regression models to test the incremental validity of motion and sound components

To directly test the incremental validity of motion and sound components to predict preference, hierarchical linear regression analyses were used,

accordingly. In the hierarchical model, cognition and emotion variables were first entered as the first step, and then motion and sound as qualitative variables were entered as the second step while the interaction term for motion and sound were entered as the third step. It was found that for the static environments, the effect of the interaction term for motion and sound was significant,  $F$  change (1, 114) = 5.35,  $R^2$  change = .025,  $p$  = .022. However, for the dynamic environment, the effect of the interaction was not significant while the main effects of motion and sound were also not significant (Table 1).

### 4. Discussion

The results reveal that the incremental validity of videos for depicting static environments is better demonstrated than that of videos for portraying dynamic environments. Such phenomenon can be explained by the discrepancy between participants' experience of the simulated environments displayed on videos and their expectations of the experience in the real environments. The stronger evidence of incremental validity for static environments indicates that it is generally less likely for people to expect motion or sound effects in static environments, and therefore when the videos provide these effects, people are more impressed with such presentations. On the contrary, motion and sound effects in the video presentations of dynamic environments seldom match what people would expect to 'feel' the atmospheric qualities of waterscapes in real environments, such as mist and smell of water. Therefore, even though the videos provide such information, their effects would not make significant impact as the effects in static environments.

**Table 1. The Adjusted R<sup>2</sup> measures when using cognition and emotion to predict participants' preference in 4 different experimental conditions**

Experime ntal conditions	Compon ents	Static environments Adjusted R <sup>2</sup>	Dynamic environments Adjusted R <sup>2</sup>
1	Condition motion + sound	.559	.400
2	Condition motion	.487	.396
3	Condition sound	.313	.395
4	Condition none	.273	.302

**Acknowledgments:** This study was supported by the National Science Council of Taiwan (NSC 101-2410-H-128-035).

## 5. References

- [1] Bronfenbrenner U. Toward an experimental ecological of human development. *American Psychologist*, 1977, 32: 513-531.
- [2] Bronfenbrenner U. *The Ecology of Human Development: Experiments by Nature and Design*. Cambridge, MA: Harvard University Press, 1979.
- [3] McKenchie G E. Simulation techniques in environmental psychology. (Stokols D ed.), *Perspectives on Environment and Behavior*. New York: Plenum Press. 1977.
- [4] Winkel G H, Sasanoff R. An approach to an objective analysis of behavior in architectural space. (Proshansky H, Ittelson W A, Rivlin L G. eds.), *Environmental Psychology: Man and His Physical Setting*. New York: Holt, Rinehart and Winston. 1970.
- [5] Bishop I D, Rohrmann B. Visualization tools: their role in understanding human responses to the urban environment, (Wyatt R, Hossein H. eds) *Proceedings of the Fourth International Conference on Computers in Urban Planning*, 1995, pp. 313-322. Melbourne: University of Melbourne.
- [6] Bishop I D, Rohrmann B. Subjective responses to simulated and real environments: a comparison. *Landscape and Urban Planning*, 2003, 65: 261-277.
- [7] Daniel T C. Data visualization for decision support in environmental management. *Landscape and Urban Planning*, 1992, 24: 149-163.
- [8] Hetherington J. Representing the environment: visual surrogates in environmental assessment, *The Proceedings of EDRA 22*, 1991, 246-252.
- [9] Huan S-C L. The validity of visual surrogates for representing waterscapes. *Landscape Research*, 2009, 34(3): 323-335.
- [10] Morgan R. Some factors affecting coastal landscape aesthetic quality assessment, *Landscape Research*, 1999, 24(2): 167-184.
- [11] Sheppard S R J. Guidance for crystal ball gazers: Developing a code of ethics for landscape visualization, *Landscape and Urban Planning*, 2001, 54: 183-199.
- [12] Ittelson, W. (Ed.) *Environment and Cognition*. New York: Seminar Press. 1973.
- [13] McKenchie G E. Simulation techniques in environmental psychology. (Stokols D ed.), *Perspectives on Environment and Behavior*. New York: Plenum Press. 1977.
- [14] Neisser U. *Cognition and Reality: Principles and Implications of Cognitive Psychology*. San Francisco: W. H. Freeman. 1976.
- [15] Wohlwill J F. Environmental aesthetics: the environment as a source of affect. (Altman I, Wohlwill J F eds.), *Human Behavior and Environment: Advances in Theory and Research*. New York: Plenum Press. 1976.
- [16] Gibson J J. *The Ecological Approach to Visual Perception*. Boston, MA: Houghton Mifflin. 1979.
- [17] Schafer M. *The Tuning of the World*. Toronto, ON: The Canadian Publishers. 1977.
- [18] Anderson L M, Mulligan B E, Goodman L S, Regen H Z. Effects of sounds on preferences for outdoor settings. *Environment and Behavior*, 1983, 15(5): 539-566.
- [19] Carles J L, Barrio I L, Lucio J D. Sound influence on landscape values. *Landscape and Urban Planning*, 1999, 43: 191-200.
- [20] Carles J L, Bernaldez F, Lucio J D. Audio-visual interations and soundscape preferences. *Landscape Research*, 1992, 17(2): 52-56.
- [21] Rohrmann B, Bishop I. Subjective responses to computer simulations of urban environments. *Journal of Environmental Psychology*, 2002, 22: 319-331.
- [22] Brown T C, Daniel T C. Effect of changes in streamflow on scenic quality: The case of the Cache-La Poudre River, *USDA Final Report A.*, USDA Rocky Mountain Forest and Range Experiment Station, Fort Collins, CO. 1989.



[23] Brown T C, Daniel T C. Landscape aesthetics of riparian environments: relationship of flow quantity to scenic quality along a wild and scenic river. *Water Resource Research*, 1991, 27: 1787-1795.

[24] Hetherington J, Daniel T C, Brown T C. Is motion more important than it sounds?: the medium of presentation in environment perception research. *Journal of Environmental Psychology*, 1993, 13(NV): 283-291.

# Intervention for Unresolved Trauma in a Developing Country After a Natural Disaster

Florence Saint-Jean, Mehmet Nurullah Akkurt, Duquesne University  
[FlorenceSaint@gmail.com](mailto:FlorenceSaint@gmail.com) [nurullahakkurt@hotmail.com](mailto:nurullahakkurt@hotmail.com)

## Abstract

*A close look at mental health in Haiti, we observe a lack of mental health services for Haitian natives. A 2012 issue of Journal of Black Psychology identified 20-23 psychiatrists and 9-30 psychiatric nurses; and 2003 Pan American Health Organization report counted 2 psychiatric hospitals in the public sector serving over 10 million. It is also reported that Haiti has the lowest rate of professional psychosocial support in the Caribbean and Latin America, and one of the lowest in the world (James, 2004). After the 2010 earthquake, the world realized how vulnerable and unprepared Haiti was to responding to natural disasters, and the mental health issues that would surface. Since the earthquake there is still unresolved trauma. Currently, there are visiting mental health professionals, however their stay and multicultural training is limited.*

*Moreover, by examining the history, education, and religious views of Haitians, we realize that there is a stigma against mental illness. Since natives are not likely to seek help from a mental health professional, and there is a recognized high prevalence of psychological trauma and adverse consequences of trauma; we introduce a culturally competent trauma intervention curriculum consisting of basic techniques that can be implemented by professionals such as teachers, doctors, nurses, and religious leaders, who are readily accessible by Haitian natives. We propose this curriculum as a pilot, which will be taught at the Haitian American Caucus (HAC) compound in Croix-des-Bouquet, Haiti in December 2013.*

*The curriculum uses basic learning methods to achieve the following objectives: 1) to develop a foundation for psycho-education and challenge stigmatized mental health ideologies. 2) to teach culturally competent professionals basic trauma assessment and intervention skills.*

## 1. Introduction

This article provides a brief review and summarization of the history of Haiti, the education

scarcity, and religious beliefs that contribute to the mental health challenges of Haitian natives, as well as exploration for future trauma interventions. The literature for mental health is scarce, however 2010 Pan American and WHO report, as well as Nicholas, Jean-Jacques, and Wheatley (2012) article provides strategies for mental health services. This article expands that research and implements key suggestions in psychological trauma intervention.

On Tuesday, January 12, 2010, a 7.0Mw earthquake ravaged Haiti and killed over 300,000 people [7]. The earthquake left recognizable destruction in infrastructure, and major issues in health and trauma, that was unstable to begin with [10].

During the first few days after the destruction, Schuller (2010) wrote, "Despite their resilience and solidarity, people were visibly exhausted and traumatized. One day, a neighbor of mine insisted I eat the chicken on her plate of food, despite the scarcity of meat. Surprised, I asked why. 'Because it looks too much like the flesh of my mother, who is still buried beneath our house,' she said."

This is not the first time Haiti has faced adversity, and Schuller is right, solidarity can only go so far. Haiti has been through slavery, dictatorship, military occupation, coup d'état (over throw), and years of violence [10]. To understand the current state of mental health and trauma in Haiti, and to intervene effectively, it is important to review these historical issues, as well as the education and religious views of Haitians; and use professionals that are readily accessible to Haitians.

## 2. History

Native Taíno/Arawak people originally occupied Haiti, a Caribbean country. After 1492 when Christopher Columbus set foot in Haiti, the country was settled by Spanish Colonists and French traders who enslaved the native people; and through maltreatment and indigenous diseases, they were killed off. Later, slaves from Africa were brought in to work the plantations established by Spain and France [4].

In 1804, Haiti after guerrilla warfare, declared its independence, and continues to hold this as one of its greatest prides. Some historians argue however that even after this, Haiti has never been left alone, and this may be the reason why the country has always had difficulties fully flourishing [4].

From 1957 to 1971, Haiti was under harsh dictatorship by President François Duvalier. For the duration of his presidency, Haiti faced one of the worst dictatorships. Throughout that time many Haitians left the country to escape turmoil. Unfortunately, these individuals were some of the most prominent and educated, causing what history calls, “Haiti’s brain drain” [5]. Haiti has yet to recover from this brain drain.

### 3. Education

Haiti’s education system is also scarce. Quality education is hard to find. Furthermore, only approximately 1% of the population is college educated [8]. In the field of mental health, most Haitians with a Masters or Doctorate earned it from other countries such as the United States, Canada, Mexico, and countries in Europe. In Haiti the highest level of degree awarded in Psychology is the Bachelor’s degree, and individuals can apply to be a licensed psychologist after that [8].

Pan-American Health Organization/WHO (2010) reported 23 psychiatrists and 9 psychiatric nurses, and Nicholas (2012) contradicted that with reports of 20 psychiatrists, 30 psychiatric nurses, 100 psychologists, and nearly 50 social workers. Nonetheless, with over 10 million people, there is still a limitation.

### 4. Religion

Many Haitians identify as Catholic and Protestant, however there tends to be some sort of Voodoo practice. Many people maintain their Christian beliefs while practicing the religion Voodoo, as Voodoo is part of the cultural for most Haitians [3,10].

Gods, also called Loas are often seen as responsible for mental health [3]. Voodoo in Haiti is not a homogenous religious system, and although common belief is that Voodoo is associated with magic and curses, many Haitian people believe that Houngans (Voodoo Priest) and Mambos (Voodoo Priestess) do not usually engage this. It is the bokor, “professional magician,” who usually buys spirits and sends curses [3].

Many Haitian people view health from two standpoints: “MaladiBondyè” which constitutes “ordinary” physical illnesses and can be healed with the aid of Western medicine or a doktè-fèy (traditional healer). “Maladifè-moun mal or maladi diab” which constitutes the invisible, secret, or magic, and can be healed by intervention of a bòkò or a traditional Houngans practitioner [10].

Haitians therefore believe in both natural and supernatural causes of illness. Mental illness is seen by many of Haitians as supernatural. Depression and psychosis may be seen as the consequence of a spell. A psychotic break may be interpreted as the outcome of a curse. Also a major depressive episode is likely to be interpreted as the consequence of a curse sent by a jealous person” [3,10].

All of these combined together- history, lack of mental health workers due to education, as well as religious constructs makes Haitian people respond to mental health differently. Haitians are considered to be a very resilient people. Haitian people do not exhibit the same symptoms as Western countries. For example, because Haitian people are used to experiencing turmoil, they can continue to conduct activities of daily living, despite what’s going on mentally. Haitian people have a saying, “Men anpil, chi pa lou,” which translates, “many hands make a load lighter.”

Researchers have long observed that culture significantly impacts the way individuals respond to mental health and treatment. Brown and colleagues (1996) noted that white individuals are more likely to report mood disturbances, while African Americans focus on physical symptoms and psychosocial stressors. This is also the case here when history, education, and religion come together to form a culture that doesn’t respond to mental health issues. Haitian people continue to function, and the oversight of mental health issues is embedded in the culture. Some people may ask then, if Haitian people continue to function and have become resilient, what is the problem? The problem is, people are still suffering and just can’t put a name to it.

After the 2010 earthquake there is still unresolved psychological trauma. There has been an increase in violence, crime, dependency [1], and suicide, and people are responding to the aftermath in different ways. The trauma is relevant and visible within the country despite functionality [11]. Depressed Haitians are expected to work, care for their children and to function normally [3].

The U.S. military is providing aid and support for this, however because of the dictatorship history,

continuous military occupancy, and the violent 2004 coup d'état (over throw) many earthquake survivors feel they have no reason to trust them. The same can be said for many large NGOs, which many Haitians perceive as having gotten rich off of their poverty [11].

In addition, there is raising concerns about the capacity of the NGO's. In the beginning there was a lot of attention to the earthquake and plenty of international aide, however soon after, they left. Others came and went after that as well. Not only is their stay limited, but they also receive little guidance and supervision [8]. Furthermore, their methods of Western psychology are not commonly the mode by which to explain and discuss feelings and symptoms of Haitians [8].

Developing a clearer understanding of Haitians' beliefs about illness and healing may assist in providing culturally effective treatment [8]. We do this by putting together the history, education, and religion. Using means that are readily accessible to Haitians and ones that they feel comfortable with, might be the way. This is why training teachers, doctors, nurses, and religious leaders will be the basis of an upcoming trauma program at The Haitian American Caucus Compound in Croix-des-Bouquet, Haiti. The pilot program will be implemented in December of 2013.

During the trauma course help professionals will: 1) develop a foundation for psycho-education and challenge stigmatized mental health ideologies. 2) learn basic trauma assessment and intervention skills.

Because Haitians don't have the right mental health language, doctors and nurses will be able to detect key indicators of trauma, such as somatic symptoms of back pain, headaches, "empty or heavy-headed" feeling, insomnia, distractibility, fatigue or low energy, poor appetite, pain in the stomach, or faintness [3,10].

Teachers are readily accessible to children, adolescents, and some parents. Also, religious leaders help people cope with mental and emotional problems. "Religion in Haiti offers a sense of purpose, consolation, and can increase self-esteem, alleviate despair and provide hope" [10]. Teachers and Spiritual leaders will therefore be taught to be allies of mental health professionals, because they can assess the needs, intervene or encourage clients to seek help, and support adherence to recommended treatments. Teachers and spiritual leaders can serve as 'consultants' or 'co-therapists'. They may be trusted more readily than conventional mental health professionals [10].

Further research is needed on effective trauma intervention for Haitians. This pilot program will need further evaluation to determine if it can be duplicated in Haiti and other developing countries.

## 5. References

- [1] Amnesty International. (2011). Aftershocks women speak out against sexual violence in haiti's camps. Retrieved from <http://www.amnesty.org/en/library/asset/AMR36/001/2011/en/57237fad-f97b-45ce-8fdb-68cb457a304c/amr360012011en.pdf>.
- [2] Brown, C , Schulberg, H., &Madonia, M. (1996). Clinical presentations of major depression byAfrican Americans and Whites in primary medical care practice, *Journal of Affective Disorders*, 41, 181-191.
- [3] Desrosiers, A., & St. Fleurose, S. (2002). Treating haitian patients: Key cultural aspects. *American Journal Of Psychotherapy*, 56(4), 508-521.
- [4] Dubois, L. (2012). *Haiti: The aftershocks of history*. New York, NY: Metropolitan Books.
- [5] Jadotte, E. (2012). *Brain Drain, brain circulation and diaspora networks in haiti*. Retrieved from <http://unctad.org/en/PublicationsLibrary/ldcr2012-bp1.pdf>
- [6] James, E. C. (2004). The political economy of 'trauma' in Haiti in the democratic era of insecurity. *Culture, Medicine and Psychiatry*, 28, 127-149.
- [7] James, L., Noel, J., Favorite, T., & Jean, J. (2012). Challenges of postdisaster intervention in cultural context: The implementation of a lay mental health worker project in postearthquake Haiti. *International Perspectives In Psychology: Research, Practice, Consultation*, 1(2), 110-126.
- [8] Nicolas, G., Jean-Jacques, R., & Wheatley, A. (2012). Mental health counseling in haiti: Historical overview, current status, and plans for the future. *Journal Of Black Psychology*, 38(4), 509-519.
- [9] Nicolas, G. et al. (2007). Expression and treatment of depression among haitian immigrant women in the United States: Clinical observations. *American Journal Of Psychotherapy*, 61(1), 83-98.
- [10] Pan American Health Organization/World

Health Organization. (2010). *Culture and mental health in haiti: A literature review*. Retrieved from [http://whqlibdoc.who.int/hq/2010/WHO\\_MSD\\_MER\\_10.1\\_eng.pdf](http://whqlibdoc.who.int/hq/2010/WHO_MSD_MER_10.1_eng.pdf)

[11] Schuller, M. (2010). Trauma and solidarity in the new haiti. *NACLA Report on the Americas*, 43(2), 4.

## What is Wrong with Multicultural Training in America?

Mehmet Nurullah Akkurt, Janelle Carter, Florence Saint-Jean

Duquesne University

[nurullahakkurt@hotmail.com](mailto:nurullahakkurt@hotmail.com), [florencesaint@gmail.com](mailto:florencesaint@gmail.com), [janelle\\_carter@hotmail.com](mailto:janelle_carter@hotmail.com)

### Abstract

*A review of the literature in Counseling demonstrates serious inadequacies and challenges with the way mental health professionals in the U.S.A. are trained in multiculturalism. For many years the mental health field in the U.S. has attempted to become an inclusive practice, with the hope that mental health professionals are not limited to Westernized philosophies and approaches; however have they been successful? The purpose of this article is to summarize research studies and findings, and discuss where the U.S. is in 2013 with multicultural competence in the mental health field; and what areas need to be improved. Since the current initiations are not adequate, this article will serve as an assessment of the problem, which eventually becomes a contribution to the lacking literature of this very sensitive topic. Finally, the article will discuss implications for future research as well which direction multicultural training needs to go in the future.*

### 1. Introduction

More attention is given to Multicultural Training of counselors in last three decades. American Counseling Association's Code of Ethics (2005) mandates training for Multicultural Counseling Competencies (MCCs), as well the Council of Accreditation for Counseling and Related Educational Program (CACREP)'s standards (2011) require counselor training programs to provide training for MCCs to be accredited. It is unethical for counselors to serve ethnic minority clients without having multicultural training according ACA Code of Ethics (2005)[1]. CACREP accredited counselor training programs have included multicultural training in their curriculum, and "Sue and Sue's model (2008) has been widely accepted as the main theoretical framework of MCC in counseling psychology and related fields" [4]. Sue and Sue (2008) proposed three areas of MCC. These areas are: a) attitudes and beliefs, b) knowledge, and c) skills. Attitudes and beliefs refer to the concept of counselors' self-awareness of their own values and

biases, while knowledge refers to understanding the worldview of culturally diverse clients. The third concept, skills, refers to counselors developing necessary skills to be able to meet the needs of clients who are culturally diverse. This model seems to be widely used by counselor educators when designing their syllabi.

### 2. Why MCT is needed

Over the past 15 years there has been more attention given to multicultural issues as it relates to practice and training [14]. Researchers have found that graduate programs do not put enough emphasis on developing multicultural counseling skills [13]. Researchers have also found that although graduate programs are recognizing the need and importance of counselors to receive MCT, fewer programs "offer a fully integrated training curriculum [13, pp.3]. In a 1999 study, Lee et al. suggested that pre-doctoral internships must train clinicians in multicultural counseling competencies, but indicated that there was less research on MCT on the internship level than during the graduate coursework [13]. Some research has also suggested that many programs are not in geographic areas that are racially diverse thus being difficult to provide clinicians with a diverse population of clients [Ponterotto, as cited in Lee et al., 1999]. Counselors should be proactive in their efforts to work with minority students [13]. Some researchers report that there is little direction given to students to assist in acquiring multicultural competencies [15]. Multicultural competence is "the ability of a counselor to respond in a sensitive and appropriate manner to those who are culturally different" [17, pp.28]. Progress in graduate programs becoming more culturally sensitive is seen in the ethnic diversity of faculty and student composition [17].

### 3. Purpose of this Article

The purpose of this article is to summarize research studies and findings, and discuss where the

U.S. is in 2013 with multicultural competence (MCC) in the mental health field; and what areas need to be improved. Even though great emphasis has been given to the topic of MCC, there have been only few studies that have evaluated the effectiveness of the current training provided. Several studies have shown the underutilization counseling services by culturally diverse clients as evidence that counselors are not well trained for MCC [1].

For the organizational purpose of this article, authors will consider the problem from three dimensions: 1) Research, 2) Training, and 3) Practice. The rationale behind sectioning this article into three parts was due to the fact that current literature is used as a primary source to design MCT courses in counseling training programs—as well as the accreditation requirements. Also, counselors in practice provide services according to training they received when working with clients from diverse cultural backgrounds. From this token, these three areas are highly interdependent and to address the current problems faced in MCT, we need to take close look at the limitations in all areas. Next section will introduce the *research* limitations that current literature states in the areas of MCC and MCT.

#### 4.1. Research

Research in the area of MCC and MCT lacks, and we observe inconsistencies in the current literature, which make it harder to take the necessary steps to improve the quality of MCT [3]. Authors have reported inconsistent findings regarding the issues related to MCC. For example, studies have yielded inconsistent findings about the relationship between MCC and racial/ethnic differences [4,2]. Another problem in the area of MCT research is that there are very few studies that examined the effectiveness of the approaches used in MCT [3]. Didactic learning seemed to be used widely as a primary delivery method, however, it is not an effective approach to use in MCT [1]. In addition, the literature consist only few studies that has focused on effective ways to teach MCT courses [1]. Even though Sue and Sue's (2008) model is widely used, it is not evaluated [4]. Most of the studies conducted in the area of MCT focus more on the content of the MCT courses. However, a study suggested that the researchers might have taken the wrong path while doing research in the area of MCT, and it might be better to place more emphasis on teaching alliance [3].

In addition, several researchers critiqued that MCT courses are designed to train White counselors

so they can work effectively with minority clients [4]. There was no emphasis on how counselors from minority groups can counsel White clients. This brings us to another criticism stated regarding MCT that Multiculturalism is not well defined, and it is often confused with social justice [6]. The distinction between social justice and multiculturalism is not clearly identified, and “absence of agreement on terms cause separation” [6].

Finally, what plays a role in MCC is still unknown [2]. Identification of key concepts that plays a role in MCC will bring a better understanding of what needs to be done in MCT. Last but not least, research in the area of MCT and MCC is limited, because studies mostly rely on a self-reported data [2]. Self-report seems to be the most common way to collect data, because other data collection procedures might result in unethical behavior or interfere with therapeutic process (e.g. asking clients to rate their counselors level of MCC).

#### 4.2. Training

With the increasing numbers of individuals migrating to the United States, it is imperative that clinicians receive adequate multicultural training. “There is a controversy among MCT educators regarding what content should be in MCT courses”[3]. Researchers have differentiated between the traditionalist approach and the multiculturalist approach. Traditionalist note that MCT should solely focus on African Americans, Asian Americans, Latinos, and Native Americans, while multiculturalist emphasize the inclusion of gender, socioeconomic status, sexual orientation, national origin, and origin [3]. Studies also showed that one class in multicultural counseling is not adequate in the training process [4], and researchers suggested that MCT should be infused in all aspects of counseling [6]. Several studies suggested that limited training causes limited sensitivity in counseling [2]. For example, in a study of 460 national certified counselors researchers found that multicultural awareness was not enhanced by more training [2]. Researchers suggest MCT may be affected by a diverse group of faculty [6], and diversity in faculty can serve as a representation of multiculturalism in the U.S.

Even though MCT courses are designed according Sue & Sue 2008 model, the skill development is ignored [3]. In a 2013 study, 54 syllabi were reviewed from APA and CACREP programs and researchers found that multicultural

courses were deficient in assessing the level of multicultural counseling skills [6]. One of the concepts that was discussed in the MCT literature was racial blindness. Research suggests that White students are trained in multicultural counseling however; there is a lack of significant research suggesting that non-White students are adequately trained to work with White clients [4]. The researchers go on to notes that ignoring race and ethnicity in training programs may result in race and ethnicity being ignored in therapy [4].

Research suggests that MCT is a significant contributor to counselors being culturally sensitive [12]. In the same study, the authors suggest that supervisors must be aware of a counselor's level of sensitivity as it relates to multicultural competencies and their ability to do that is based on the supervisors' level of MCT. Recognizing the needs of international counseling students is also important as it pertains to their native culture and host culture [16].

Finally, researchers indicated that although there is extensive literature on multicultural competency, there is little to attention given to how programs should teach the student [1]. Therefore, there is a lack of literature on effective ways to teach MCT courses.

#### 4.3. Practice

Cultural-diverse clients who prematurely terminate from counseling services and underutilize counseling services show that counselors are not trained in multicultural competencies [1]. Even though MCT prepare counseling students to cognitively understand culturally diverse clients, a lack of reflective training causes no change in their affect in the counseling session [1]. Specifically, counselors may unknowingly show bias or judgment towards their culturally diverse client in therapy.

The clinician may find it difficult to relate to the client when cultural differences exist [15]. Most research examines MCT for counselors and clients from the United States, however international students are often not taken into consideration as it relates to multicultural competencies [16]. The development of multicultural competencies is a gradual process and occurs over time [17]. Researchers have suggested various methods to assist counselors-in-training to develop multicultural competencies such as the use of portfolios [17]. In the 2006 study Coleman, Morris, and Norton found that the development of multicultural portfolio and ecological case formulation may be an effective in

aiding counselors-in-training to develop multicultural competencies. Awareness of the counselor's own cultural background is also important in developing multicultural competencies and awareness [17].

#### 5. Conclusion

The purpose of this article was to identify areas of MCT that needs improvement to help counselor educators to design their MCT courses in an effective way. We hope that the limitations stated in this article will be taken into consideration, and this will increase the quality of MCT education.

#### 6. References

- [1] B.S.K. Kim, and H. Z. Lyons, "Experiential activities and multicultural counseling competence training", *Journal of Counseling & Development*, American Counseling Association, Virginia (USA), 2003, pp. 400-408.
- [2] R.C. Chao, "Racial/ethnic identity, gender-role attitudes, and multicultural counseling competence: The role of multicultural counseling training", *Journal of Counseling & Development*, American Counseling Association, Virginia (USA), 2012, pp. 35-44.
- [3] P.E. Priester, J.E. Jones, C.M. Jackson-Bailey, A. Jana-Masri, E.X. Jordan, and A.J. Metz, "An analysis of content and instructional strategies in multicultural counseling courses", *Journal Of Multicultural Counseling And Development*, American Counseling Association, Virginia (USA), 2008, pp. 29-39.
- [4] R.C. Chao, M. Wei, G.E. Good, and L.Y. Flores, "Race/ethnicity, color-blind racial attitudes, and multicultural counseling competence: The moderating effects of multicultural counseling training" *Journal of Counseling Psychology*, American Psychological Association, District of Columbia (USA), 2011, pp. 72-82.
- [5] S.D. Smith, and K. Ng, "International counseling trainees' experiences and perceptions of their multicultural counseling training in the united states: A mixed method inquiry", *International Journal for the Advancement of Counselling*, Springer, USA, 2009, pp. 271-285.
- [6] A.L. Pieterse, S.A. Evans, A. Risner-Butner, N.M. Collins, and L.B. Mason, "Multicultural



competence and social justice training in counseling psychology and counselor education: A review and analysis of a sample of multicultural course syllabi”, *The Counseling Psychologist*, Sage, USA, 2009, pp. 93-115.

[7] G.L. Dickson and D.A. Jepsen, “Multicultural training experiences as predictors of multicultural competencies: Students' perspectives”, *Counselor Education and Supervision*, American Counseling Association, Virginia (USA), 2007, pp. 76-95.

[8] L.G. Castillo, D.F. Brossart, C.J. Reyes, C.W. Conoley, and M.J. Phoummarath, “The influence of multicultural training on perceived multicultural counseling competencies and implicit racial prejudice” *Journal of Multicultural Counseling and Development*, American Counseling Association, Virginia (USA), 2007, pp. 243-254.

[9] G.L. Dickson, D.A. Jepsen, and P.W. Barbee, “Exploring the relationships among multicultural training experiences and attitudes toward diversity among counseling students”, *Journal of Multicultural Counseling and Development*, American Counseling Association, Virginia (USA), 2008, pp.113-126.

[10] R.A. Middleton, B. Ergüner-Tekinalp, N.F. Williams, H.A. Stadler, and J.E. Dow, “Racial identity development and multicultural counseling competencies of white mental health practitioners”, *International Journal of Psychology & Psychological Therapy*, University of Almeria, Brazil, 2011, pp. 201-218.

[11] R.C. Chao, and S.R. Nath, “The role of ethnic identity, gender roles, and multicultural training in college counselors' multicultural counseling competence: A mediation model”, *Journal of College Counseling*, American Counseling Association, Virginia (USA), 2011, pp. 50-64.

[12] R.J. Steward, D.J. Wright, J.D. Jackson, and H.I. Jo, “The relationship between multicultural counseling training and the evaluation of culturally sensitive and culturally insensitive counselors”, *Journal of Multicultural Counseling and Development*, American Counseling Association, Virginia (USA), 1998, pp.205-217.

[13] R.M. Lee, L. Chalk, S.E. Conner, N. Kawasaki, A. Jannetti, T. LaRue, and E. Rodolfa, “The status of multicultural counseling training at counseling

internship sites”, *Journal of Multicultural Counseling and Development*, American Counseling Association, Virginia (USA), 1999, pp. 58-74.

[14] J.E. Manese, J.T. Wu., and C.A. Nepomuceno, “The effect of training on multicultural counseling competencies: An exploratory study over a ten-year period”, *Journal of Multicultural Counseling and Development*, American Counseling Association, Virginia (USA), 2001, pp. 31-40.

[15] A. Seto, S. Young, K.W. Becker, and M.S. Kiselica, “Application of the triad training model in a multicultural counseling course” *Counselor Education and Supervision*, American Counseling Association, Virginia (USA), 2006, pp. 304-318.

[16] K. Ng, and S.D. Smith, “Training level, acculturation, role ambiguity, and multicultural discussions in training and supervising international counseling students in the united states”, *International Journal for the Advancement of Counselling*, Springer, USA, 2012, pp. 72-86.

[17] H.L.K. Coleman, D. Morris, and R.A. Norton, “Developing multicultural counseling competence through the use of portfolios”, *Journal of Multicultural Counseling and Development*, American Counseling Association, Virginia (USA), 2006, pp. 27-37.

# A Study into the Learning Environment for the Course in Social Studies and the Need for Materials to Build Up Knowledge and Experiences about Thai History among Secondary Students

Kuntida Thamwipat and Suwanee Suwanpat  
Department of Educational Communication and Technology  
Faculty of Industrial Education and Technology  
King Mongkut's University of Technology Thonburi  
[kuntida.tha@kmutt.ac.th](mailto:kuntida.tha@kmutt.ac.th), [saw-sun@hotmail.co.th](mailto:saw-sun@hotmail.co.th)

## Abstract

*This research was aimed to study the status of respondents, to examine the learning environment for the course in social studies, and to study the need for the materials to build up experiences about Thai history among secondary students at Surat Thani School. The sampling group in this study consisted of 400 students from Year 7 to Year 12 out of 12 classrooms, i.e. 2 classrooms from each year were chosen using simple random sampling method. The tool for data collection was 5-rating scale questionnaire with the reliability of 0.96. The data were analyzed using percentage, mean ( $\bar{x}$ ) and standard deviation (S.D.). The research results showed that the learning environment for the course in social studies among secondary students at Surat Thani School was at good level ( $\bar{x} = 3.90$ ; S.D. = 0.60). When each aspect was considered, it was found that the learning environment about the student behavior and practical matters was at good level ( $\bar{x} = 4.11$ ; S.D. = 0.49) or the highest among all, followed by the learning environment about instructors and about the classmate behaviors. The need for materials to build up experiences about Thai history among secondary students in Surat Thani School was at high level ( $\bar{x} = 3.81$ ; S.D. = 0.78). It was found that the aspect of the greatest need was the usage of materials and local speakers, video clips, movies and songs about Thai history and this aspect was followed by the instructional activities, school trips to historic sites, play performances and games about Thai history.*

## 1. Background and significance

Thailand's National Education Act of B.E. 2542 (1999) and Amendments B.E. 2545 (2002), Chapter 4 Section 22 states that "Education shall be based on the principle that all learners are capable of learning

and self-development, and are regarded as being most important. The teaching-learning process shall aim at enabling the learners to develop themselves at their own pace and to the best of their potentiality." In Section 4, education is defined as "the learning process for personal and social development through imparting of knowledge; practice; training; transmission of culture; enhancement of academic progress; building a body of knowledge by creating a learning environment and society with factors available conducive to continuous lifelong learning." Chapter 4, Section 24 (5) also states that educational institutions shall "enable instructors to create the ambiance, environment, instructional media, and facilities for learners to learn and be all-round persons, able to benefit from research as part of the learning process." Therefore, the instruction in each educational institution shall comply with the National Education Act so that the learners could learn to achieve the instructional goal and to gain the most efficiency [1].

The course in social studies, religion and culture enables learners to understand the living conditions of humans as both individuals and social beings as well as social adjustments to make use of limited resources. The course also helps learners to understand the changes in each era according to the factors so that they could understand themselves and others. The learners will endure and accept the differences and exert their virtues in their daily life to become a good citizen of the nation and of the world [2].

A portion of the message assigned to the educational personnel by Her Majesty Queen Sirikit on the 12th August, 2008 about the concern for the course in Thai history reads: "The ancestors of Thailand have painted the earth with their blood so that we can live comfortably. What a country! However, there is no course in history and where Thai people are from is still a mystery. This is a

strange idea. In the US, history is taught, especially the history of the nation. Each country has their course in their history except for Thailand. Who helps Thailand to survive up till now? This is shocking.” [3]

After listening to the message by Her Majesty the Queen, Thai people become aware of Thai history and the origin of Thai ancestors up to the present moment. Therefore, it is important to inculcate the understanding of Thai history into students. Teachers can use a variety of teaching methods and materials to impart the knowledge of Thai history.

The Office of the Permanent Secretary, Ministry of Education [4] found that the learning achievement of Thai history was at low level due to lack of Thai history teachers and the instructional method based on lecture as well as the comparably small amount of Thai history in the national curriculum. Therefore, Ministry of Education has put more contents about Thai history so that teachers realize that the course is important and that all teachers are responsible for this course.

According to the research background mentioned above, the researchers who are teaching the course in social studies would like to study the problems in order to understand the level of opinion about the learning environment for the course in social studies and the approach to materials in order to build up knowledge and experiences about Thai history among secondary students.

## **2. Research objectives**

1. To study the learning environment of the respondents about the course in social studies for secondary students at Surat Thani School about the instructor behaviors, the student behaviors, the classmate behaviors as well as the buildings, classrooms, and instructional materials.

2. To study the need for materials to build up knowledge and experiences about Thai history for secondary students at Surat Thani School.

## **3. Expected outcomes**

1. The data from this research will be used to provide an approach to the learning environment for the course in social studies and the usage of materials to build up knowledge and experiences about Thai history.

2. This research will directly benefit the teachers of the course in social studies in that they could revise and develop the learning environment for the

course in social studies as well as meet the need for materials to build up knowledge and experiences about Thai history.

## **4. Research scope**

The research scope of the study into the learning environment for the course in social studies and the need for materials to build up knowledge and experiences about Thai history among secondary students was as follows:

### **4.1. Population**

The population in this study was 3,166 students from Year 7 to Year 12 in the second term of the academic year 2012.

### **4.2. Sampling group**

The sampling group in this study was chosen using simple random sampling method out of all years from Year 7 to Year 12 for 400 students according to Yamane’s formula with the statistical significance at the .05 level.

### **4.3. The variables in this study**

The variables in this study consisted of the independent variable which was the data about the status of students such as gender, level, learning achievement for the course in social studies and the classroom syllabus.

The dependent variables included

1. The learning environment of school about the course in social studies in terms of instructor behaviors, student behaviors, classmate behaviors as well as the buildings, classrooms and materials

2. The need for the materials to build up knowledge and experiences about Thai history.

## **5. Research method**

In this research, the questionnaire which met the validity and the reliability criteria was used for data collection. The questionnaire contained three following parts:

Part 1: The general data of the respondents

Part 2: The learning environment for the course in social studies

- The instructor behaviors
- The student behaviors
- The classmate behaviors

- The buildings, classrooms and materials

Part 3: The need for materials to build up knowledge and experiences about Thai history

The questionnaire was first piloted with 30 students outside the sampling group and then it was analyzed for the reliability according to Cronbach's alpha with the result of 0.96. Then the questionnaire was used to collect the data with the sampling group for data analysis with mean and standard deviation.

## 6. Research results

The research results of the study into the learning environment for the course in social studies and the need for materials to build up knowledge and experiences about Thai history among secondary students could be summarized in Table 1 below:

**Table 1.** Shows the results about the learning environment for the course in social studies.

Item	Opinion Level		
	$\bar{x}$	S.D.	Meaning
1. The instructor behaviors			
1.1 Teaching technique	3.79	0.68	Good
1.2 The instruction behaviors and classroom ambiance	4.07	0.69	Good
1.3 The assessment	4.02	0.69	Good
Mean	3.96	0.59	Good
2. The student behaviors			
2.1 The behavior relationship with the family	4.33	0.58	Good
2.2 The behavior relationship with learning	4.10	0.67	Good
2.3 The relationship with friends and instructors; feelings and emotions	3.91	0.64	Good
Mean	4.11	0.49	Good
3. The classmate behaviors			
3.1 The learning interest	3.87	0.58	Good
3.2 The learning behaviors of the	3.87	0.58	Good

classmates			
Mean	3.87	0.58	Good
4. The buildings, classrooms and materials			
4.1 The buildings and classrooms	3.59	0.86	Good
4.2 The learning materials	3.79	0.76	Good
Mean	3.69	0.76	Good
Overall Mean	3.90	0.60	Good

According to Table 1, the learning environment for the course in social studies among secondary students at Surat Thani School was at good level. The overall mean was 3.90 with standard deviation of 0.60. The first highest aspect was the learning environment about student behaviors with mean of 4.11 and standard deviation of 0.49, followed by the learning environment about instructor behaviors with mean of 3.96 and standard deviation of 0.59, the learning environment about classmate behaviors with mean of 3.87 and standard deviation of 0.58, and the learning environment about the buildings, classrooms, and materials with mean of 3.69 and standard deviation of 0.76, respectively.

**Table 2.** Shows the results about the need for materials to build up knowledge and experiences about Thai history.

Item	Opinion Level		
	$\bar{x}$	S.D.	Meaning
The need for materials to build up knowledge and experiences about Thai history			
1. The instructional activities	3.79	0.76	Good
2. The usage of materials and local speakers	3.83	0.89	Good
Mean	3.81	0.78	Good

According to Table 2, the need for materials to build up knowledge and experiences about Thai history was at high level with mean of 3.81 and standard deviation of 0.78. Both aspects of the need were at high level. The need for the usage of materials and local speakers was at the greatest need with mean of 3.83 and standard deviation of 0.89, followed by the instructional activities with mean of 3.79 and standard deviation of 0.76.

## 7. Research discussions

This research about the study into the learning environment for the course in social studies and the need for materials to build up knowledge and experiences about Thai history among secondary students could be discussed as follows:

### 7.1. The learning environment for the course in social studies

It was found that secondary students in general perceived their learning environment at good level ( $\bar{x} = 3.90$ ; S.D. = 0.60). This finding complies with the one by Chalerm Promkunaphon [6] whose research into the learning environment of students in the Learning Opportunity Expansion Project of the Educational Area 12 under the supervision of National Board of Education with 944 Year 9 students in the academic year 1995 showed that the majority of male and female students at small schools, medium schools and large schools perceived their learning environment, both overall and in each aspect, at good level. To explain this, Sumon Amornwiwat [7] says that good learning environment and good learning ambience will build up faith, belief and trust among learners so that they gain interest, persevere and change their behaviors according to the instructional objectives. Similarly, Orapan Prasittirat [8] says that many types of learning environment, both in classrooms and at educational institutions including the relationship with the instructors, have an impact on the development and the growth of students because the environment will shape their social behaviors in the future.

### 7.2. The need for materials to build up knowledge and experiences about Thai history

It was found that the secondary students at Surat Thani School expressed the great need for materials to build up knowledge and experiences about Thai history ( $\bar{x} = 3.81$ ; S.D. = 0.78). This finding complies with Michaelis [9] who suggests the use of local resources to teach history. The use of daily experiences as encountered by students, the school trips as well as the guest speakers or the experts to allow students to discuss the topics of interest will help students significantly. Instructors could choose a suitable approach to meet the needs of the learners so that they could learn effectively and their experiences become meaningful. History teachers should organize

activities to meet the needs of their students, either by inviting a guest speaker, organizing an exhibition about Thai history, running a group discussion, or taking part in a local community. This will benefit the students the most. The instructors could choose the materials to match the contents, the interests, the environments and the activities of the students.

## 8. Suggestions

### 8.1. Suggestions from the research results

1. According to the research results, the learning environment for the course in social studies was at good level and the need for materials to build up knowledge and experiences about Thai history among secondary students was at high level. To apply the research results, schools should organize a good learning environment with high quality. There could be a workshop session provided for teachers so that they could learn how to use materials. Each school should encourage their teachers to know Thai history so that they could organize a learning environment and develop a learning material to teach effectively. The significance of learning environment inside the classroom and outside the classroom should be recognized and the learning materials should be provided for teachers.

2. According to the research results, the learning environment about the instructor behaviors was at good level. To apply the research results, instructors should be encouraged to teach with the principle that learners are the center of the class. There can be many teaching techniques and students should be allowed to work with others. Teachers could use modern educational innovations as well as invite local speakers to provide lessons, depending on the needs of the students. Teachers with enthusiasm usually explain the contents clearly. The assessment should also be fair so that the students could gain a better learning achievement.

3. According to the research results, the learning environment about the student behaviors was at good level. To apply the research results, it is important that teachers, parents and all persons concerned should encourage students to recognize the significance of learning. They should facilitate students in learning and finding the additional learning materials. Moreover, they should act as a mentor to connect many students so that students could learn how to work together and build a good relationship between teachers and students so as to develop their knowledge and skills gradually.

4. According to the research results about the classmate behaviors, it was at good level. To apply the research results, teachers need to encourage students to pay attention to the instruction and to be honest. The love and the compassion should be built up in the classroom and the organization so that students collaborate and help one another to finish the assignment. This will bring good advantages to the students and the school as well as the society and the nation in the future.

5. According to the research results, the learning environment about the buildings, classroom and materials was at good level. To apply the research results, there should be improvements for the buildings and the classrooms, especially computer rooms and overhead projects to facilitate the instruction.

6. According to the research results, the need for materials to build up knowledge and experiences about Thai history was at high level. To apply the research results, the instructors should adopt a new teaching method by using more materials about history or asking local experts to give a speech or asking students to interview other local people or taking them on a school trip. Other media should also be used in the classroom, such as photos, DVD players, multimedia, audio recordings, history songs, history films, books, magazine and the like. This will influence the learning behaviors by stimulating the learners to better understand Thai history and to remember the events for longer.

## 8.2. Suggestions for further research

1. There should be a study into the learning environment and the impact on the lower secondary students about the room rotation approach at Surat Thani School.

2. There should be a study into the learning environment and the approach to build up a learning environment to boost up learning in the classroom.

3. There should be a study into the learning environment and the need for materials to build up knowledge and experiences about the courses in geography, economics, Buddhism and politics.

4. There should be a study into the development of multimedia to develop the instruction for the course in Thai history.

## 9. References

[1] Ministry of Education, 2003, *National Education Act B.E. 2542 (1999) and Amendment (Second*

*National Education Act B.E. 2545 (2002))*, Bangkok: Express Transportation Organization Printing Press.

[2] Bureau of Academic Affairs and Educational Standards, Office of the Basic Education Commission, Ministry of Education, 2009, *The Learning Index and Core Learning Contents in the Subject Group of Society, Religion and Culture according to the Basic Core Curriculum B.E. 2551 (2008)*, Bangkok: The Agricultural Co-operative Federation of Thailand Printing Press, p. 1.

[3] Wutinan Pachuenjai, 2010, *How to Teach History to Become Patriotic*, [Online], Available : <http://www.sahavicha.com/?name=article&file=readarticle&id=1481>, [2012, September 25].

[4] The Office of the Permanent Secretary, Ministry of Education, 2000, *The Activity Manual for History Teaching: How to Learn Thai History?*, Bangkok: Religion Printing Press, p. 1.

[5] Student Registrar, Surat Thani School, Office of the Basic Education Commission, Secondary School Area 11, Ministry of Education, 2012, *Student Report for 2012*, Surat Thani School, p. 31.

[6] Chalorm Promkunaphon, 1995, *A Study into the Learning Environment of Students in the Educational Opportunity Expansion Project of the Educational Area 12 under the Supervision of National Education Board*, Master's thesis in Educational Administration, Graduate School, Burapha University, p. 31.

[7] Sumon Amornwiwat, 1987, *Teaching with Faith and Yonisomanasikara Approach*, Second Impression, Bangkok: Odeon Store Printing Press, pp.92-93.

[8] Orapan Prasittirat, 1990, *A Study into the Learning Environment of Students at the Faculty of Education, Srinakharinwirot University*, Research Report from the Educational Technology Discipline, Faculty of Education, Srinakharinwirot University, p. 48.

[9] Michaelis, John U., 1972, *Social Studies for Children in a Democracy: Recent Trends and Developments*, Englewood Cliffs, New Jersey : Prentice-Hall, pp.498-499.



## 10. Appendix

These photos show the aspects of instructor behaviors, student behaviors and classmate behaviors.



Figure 1. Shows the aspects of instructor behaviors and student behaviors.



Figure 2. Shows the aspects of classmate behaviors.

These photos show the aspects of the buildings and the instructional materials.



Figure 3. Shows the aspects of the buildings.



Figure 4. Shows the aspects of the instructional materials.

## **Economics and Finance**



# Economic Analysis of Contract Modification

Jong Il Park, Kimoon Cheong  
Gachon University, Kangwon National University  
[jongil.park@e-haenglim.com](mailto:jongil.park@e-haenglim.com) , [kimoon@kangwon.ac.kr](mailto:kimoon@kangwon.ac.kr)

## Abstract

*The contract law is based on the premise of the bilateral voluntary exchange. In a market economic system, such exchanges involve a process in which the parties bargain voluntarily, each seeking to maximize her own economic advantage on terms that are acceptable to the other party. The presumption is that this process yields a "Pareto improvement" in which at least one party is better off and neither party is worse off than the case without exchange. The same logic can be applied to the contract if the parties to a contract want to modify it due to some changes in circumstances.*

*Breach of contract is generally made when a change in the environment or contingency occurs after the contract is signed but before it is performed. In some cases, it may be possible that breach of the contract can be avoided if the court enforces to renegotiate and modify the contract. Traditionally, however, courts have not enforced such contract modifications under the pre-existing duty rule. This paper is going to show that when the performance of the original contract incurs too much cost due to the change in the circumstances, the enforcement of contract modification may be more efficient than the enforcement of the original contract or breach of it under some conditions.*

## 1. Introduction

Property rights and voluntary exchange are two most important conditions for the function of market system. However, voluntary exchange is not guaranteed for free. It requires various transaction costs, especially contract costs. And many of the institutions are designed to lower the transaction costs. Thus the objectives of contract law are to economize the contracting activities and to minimize transaction costs or contract costs.

Contract law is based on the freedom of bilateral voluntary exchange. In a market economy, such

exchanges involve a process in which the parties bargain voluntarily, each striving to maximize her own economic advantage on terms that are acceptable to the other party. The presumption is that this process yields a "Pareto improvement" in which at least one party is better off and neither party is worse off than would have been the case without the exchange.

The same logic suggests that if the parties to a contract wish to modify it due to some changes in economic circumstances, then modifications should yield further Pareto improvement.

Breach of contract is generally made when a change in the environment occurs after the contract was signed but before it was performed. In some cases, breach can be avoided if the parties can renegotiate the contract. Suppose a seller (S) makes a contract to supply a buyer (B) with some goods at price P. But S found that the cost of production unexpectedly rose above P. S may still be induced to perform for B if the price is adjusted. Traditionally, however, courts have not enforced such contract modifications under the pre-existing duty rule: the promise by B to pay a higher price is not supported by new consideration from S (Posner, 1977).

This paper is going to show that when the performance of the original contract incurs too much cost due to the change in the circumstances, the enforcement of contract modification may be more efficient than the enforcement of the original contract or breach of it under some conditions.

## 2. Scenario

Consider a contract between two risk-neutral parties, a buyer, B, and a seller, S. The contract is such that S should deliver a good or perform any service to B by some specified future date. The price P is set when the contract is signed and is payable at the time of performance. Suppose that V is the value of performance to B, where  $V > P$ . Assume that B cannot

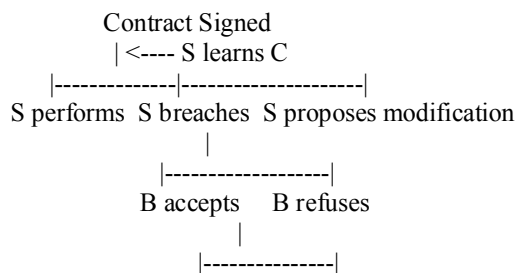
easily obtain a substitute because of the nature of the good or service when S fails to perform. Assume also that S knows this, as well as the value of V.

In order to perform the contract, the cost of C is incurred to S, which is either the cost of production or performing the service. It is assumed that at the time when the contract is signed, C is not known with certainty, although its distribution is known to both parties. Because it is assumed that  $P > E(C)$ , the contract is mutually beneficial in terms of expected value. At some time prior to performance, the cost C is assumed to be learned by S and possibly by B.

If the contract is a fully contingent one, it would include provisions for all possible cases of C, perhaps in the form of a price adjustment schedule for each C or the cases for nonperformance (e.g., liquidated damages). In general, because complete contracts are too costly to write, complete contracts are rare in reality and thus incomplete contracts are common. (Shavell, 1984). Once the value of C is learned, S has three options: (i) to perform the contract as written, (ii) to breach the contract, or (iii) to propose modification of the contract. If S chooses to perform the contract, B receives a payoff of  $V - P$  and S receives a payoff of  $P - C$ . If S breaches the contract, S will pay B damages of  $d$ , and both parties will incur litigation costs. If the remedy is expectations damages, and the latter perfectly compensates B for performance,  $d = V - P$ . However, in reality, expectation damages may not be a substitute for performance. Therefore, it is assumed that  $d \leq V - P$ .

Finally, S can propose a third option, the modification of the contract: B pays a bonus  $b$  above the original price  $P$  as a condition for performance. Faced with this proposal, B can either reject or accept  $b$ . If he rejects  $b$ , S must either perform or breach the contract, yielding the payoffs from cases (i) or (ii). If he accepts  $b$ , S performs at the new price. B's payoff in this case is thus  $V - P - b$ , and S's payoff is  $P + b - C$ , assuming that there is no costs for renegotiation.

Figure 1 shows the sequence of events and decision tree. And Table 1 summarizes payoffs of B and S for each case.



S performs breaches

**Figure 1. Sequence of Events**

**Table 1. Payoffs of S and B**

	S	B	SW = S+B
Contract performed	P-C	V-P	V-C
Contract breached	-d	d	0
Contract modification	P+b-C	V-P-b	V-C

### 3. Equilibrium

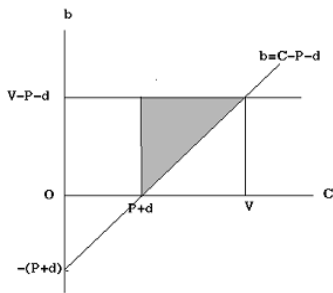
To make the equilibrium be sub-game perfect, let us begin at the final stage of the game and work in reverse sequence. First, consider the final stage at which B has refused S's proposal to renegotiate, so S must decide whether to perform or breach the contract. From above, S's payoff from performing is  $P - C$ , and her payoff from breach is  $-d$ .

Thus, S will perform if

$$(1) \quad P - C \geq -d \text{ (or } d \geq C - P),$$

and breaches if the reverse is true. Since  $d > 0$ , the equation (1) implies that a sufficient (but not necessary) condition for performance is  $P - C > 0$ . In other words, whenever the contract is profitable for the seller, she will perform.

Next consider the previous stage at which B decides whether to accept or refuse to pay  $b$ . Since B knows the value of C, she knows what S will do if she refuses. Suppose first that (1) is satisfied so B knows S will perform if she refuses  $b$ . In this case, B will only accept  $b$  if it yields a higher return than performance; that is, if  $V - P - b \geq V - P$ , or if  $b \leq 0$ . Thus, if (1) holds, B will never accept S's demand for a higher price.



**Figure 2. Equilibrium**

Suppose the equation (1) does not hold, so B knows S will breach the contract if she refuses b. In this case, the payoffs imply that B will accept b if and only if

$$(2) \quad V - P - b \geq -d \text{ or } (b + d \leq V - P).$$

Given that modification may occur, consider S's choice among her three options: performance, breach, or proposing modified performance given the realized value of C. First suppose  $P - C \geq -d$ . In this case, S prefers performance to breach, and that B would refuse any proposal to renegotiate a higher price. Thus, S performs.

Now suppose  $P - C < -d$ . In this case, S would choose breach the contract rather than perform, and B can be induced to renegotiate a higher price when (2) holds. Then the question at this stage is whether S will propose that B pays a bonus b or choose to breach the contract at the cost of d. The condition for S to propose b is given by

$$(3) \quad P + b - C \geq -d \text{ (or } b + d \geq C - P).$$

Note that condition (2) defines a lower bound on b + d, while condition (3) defines an upper bound.

Combining the above conditions, it can be shown that a positive range exists if  $V \geq C$ . Therefore, modified performance will never occur when performance is inefficient, i.e.,  $C > V$ .

Figure 2 illustrates that the outcomes of the contracting process as a function of the realized cost of performance, C. For example, performance at the original price occurs when  $C \leq P + d$ , since B will never accept a price increase over this region. The region where B accepts a price increase in exchange for performance is given by the triangle whose sides

are given by  $V - P - d$  (the upper bound on b),  $C - P - d$  (the lower bound on b and the upper bound on C), and  $C = P + d$  (the lower bound on C). Notice that the size of this region depends on the magnitude of d. As d increases (or as B expects to obtain a larger share of any pretrial settlement), the region of modified performance shrinks. Finally, breach of the contract occurs for values of C and b to the right of the boundary line  $C - P - d$ .

The following conclusions can be drawn from the analysis. First, modified performance can only occur for intermediate values of C, where  $P + d < C < V$ . Modification will not occur for low values of C because the buyer knows the seller will perform if she refuses to pay b; and it will not occur for high values of C because the maximum b that the buyer will accept leaves the seller worse off than breaching the contract. Second, modification of the contract is mutually beneficial for the two parties if it occurs. Third, the opportunism is not possible because B also observes realized cost C. But when B cannot observe the cost of C, opportunism of S may be possible.

#### 4. Efficiency of Contract Modification

The conditions under which modification will occur in equilibrium have been established. Does the modification increase the efficiency of contracting? We can conclude that performance is efficient if and only if the value of performance to B exceeds the cost of performance to S, that is, if and only if  $V \geq C$ .

The results in the preceding section, as summarized in Figure 2, show that modified performance, coupled with breach of the contract by S, potentially duplicates this outcome. In particular, performance occurs without modification up to  $C = P + d$ , and then with modification up to a point somewhere in the triangle in Figure 2. Recall that the particular point depends on the bargaining between the parties over the value of b, but notice that as C increases, the range for b narrows to a single point exactly when  $C = V$ , the limit of efficient performance. Thus, modified performance potentially occurs up to that point, and thereafter, S breaches the contract.

#### 5. Concluding Remarks

It has been shown that enforcement of contract modifications can enhance the efficiency of contracting, given costless bargaining, when B observes the realized cost of performance. This is true because there is no threat of opportunism by S. Modification can only occur when performance is efficient. Thus

enforcement of modifications is socially desirable, provided that the promisee can observe the promisor's cost of performance.

It was shown that when buyers can observe the cost of performance of sellers, renegotiation could occur only in those cases where it results in a Pareto improvement. Thus enforcement of modifications under these conditions is desirable. However, when the buyer cannot observe the seller's cost of performance, opportunistic renegotiation by sellers is possible.

### References

[1] Cooter, R. and T. Ulen (2008), *Law and Economics*, 5<sup>th</sup> ed., Addison Wesley, 2008.

[1] Posner, R. (1977), "Gratuitous Promises in Economics and Law," *Journal of Legal Studies*, 6, 411-426.

[3] Posner, R. (1992), *Economic Analysis of Law*, 4th ed., Little-Brown.

[4] Rogerson, W. P. (1984), "Efficient Reliance and Damage Measures for Breach of Contract," *Rand Journal of Economics*, 15, 39-53.

[5] Shavel, S. (1984), "The Design of Contracts and Remedies for Breach," *Quarterly Journal of Economics*, 99, 121-48.

# The Conditional Equity Premium, Cross-Section Returns and Stochastic Volatility

*Ka Wai Terence Fung*

*Division of Business and Management, United International College, Zhuhai, China*

[econfkw@hotmail.com](mailto:econfkw@hotmail.com)

*Chi Keung Marco Lau*

*Division of Business and Management, United International College, Zhuhai, China*

[marcolau@uic.edu.hk](mailto:marcolau@uic.edu.hk)

## Abstract

*Bansal and Yaron [1] demonstrate, by calibration, that the Consumption-Based Capital Asset Pricing Model (CCAPM) can be rescued by assuming that consumption growth rate follows a stochastic volatility model. They show that the conditional equity premium is a linear function of conditional consumption and market return volatility, which can be estimated handily by various Generalized Autoregressive Conditional Heteroskedasticity (GARCH) and Stochastic Volatility (SV) models. The null hypothesis is that, if Bansal and Yaron estimator is unbiased, the instrumental variables for estimating conditional equity premium should no longer be significant. We find that conditional consumption and market volatilities is capable of explaining cross section return differences. The EGARCH volatility can explain up to 55% variation of return and the Exponential GARCH*

*(EGARCH) model augmented with  $\widehat{cay}$  greatly enhance model performance. Once the theoretical conditional risk premium is added to the model, it renders all instrumental variables redundant. Also, the model prediction is consistent with observed declining equity premium.*

## 1. Introduction

Financial derivatives can be priced in two methods - relative pricing and absolute pricing. Financial engineers, on the one hand, price a financial instrument by forming a replicating portfolio. The cash flow of a call option, for instance, can be replicated by holding stock shares and shorting bonds. The option is priced relative to the market prices of those two assets.

Financial economists, on the other hand, explore the links between asset returns and macroeconomic variables which are the sources of systematic risk. One of the early attempts is the Sharpe-Lintner-Black

Capital Asset Pricing Model (CAPM), in which excess return of market portfolio is the common factor that explains cross-sectional return differences. In a two period model with exogenous labor income, the equity premium is proportional to the aggregate consumption growth, in which the multiplicative factor is elasticity of intertemporal consumption substitution. This is the famous Consumption Based Capital Asset Pricing Model (CCAPM).

In spite of the theoretical simplicity and elegance of CAPM; when faced with empirical testing, it fails miserably. For instance, Banz [2] identifies the small firm effect - small cap stocks and value stocks have unusually high average returns, while the return of large and growth stocks is lower than what CAPM predicts. Fama and French [14] demonstrate that CAPM virtually has no power in explaining cross-sectional return when sorted by size and book-to-market ratios. Fama and French [14] advocate a three factor model - market return, the return of small less big stocks (SMB), and the return on a portfolio of high book-market stocks less low book-market stocks (HML). The Fama and French model is a resounding success; however, it is still not clear how these factors relate to underlying macroeconomic risk. In fact, the independence and economic interpretation of SMB and HML remain as a source of controversy.

An alternative to the Fama and French model is the macroeconomic factor model, in which the factors are observed macroeconomic variables that are assumed to be uncorrelated to the asset specific error. Chen, Roll and Ross[9] multi-factor model is one of those. They construct surprise variables by using the Vector Autoregressive Model (VAR). The VAR residuals of several macroeconomic variables, for example, Consumer Price Index (CPI), industrial production growth and oil price are used as uncorrelated macroeconomic variables. While the uncorrelatedness

of those macroeconomic variables is less controversial, the explanatory power is unsatisfactory especially when compared to Fama and French model.

Jagannathan and Wang [20] attribute the failure of CAPM to two reasons. First, CAPM holds in a conditional sense, not unconditionally. The stochastic discount factor is linear as stated in CAPM, but the coefficients are time varying. The static specification of market premium fails to take into account the effect of time-varying investment opportunities in the calculation of asset risk. For instance, the betas of firms with relatively higher leverage rise during recession; firms with different types of assets will be affected by the business cycle in different way. Second, the return on value-weighted portfolio of all stocks is a bad proxy to wealth return. As a matter of fact, Roll[24] argues that the market return cannot be adequately proxied by an index of common stocks. The problems are rectified by estimating a conditional version of CAPM and including human capital return, as an instrumental variable, into the model. They argue that with certain assumptions about the stochastic conditional expected excess return on zero-beta portfolio and conditional market risk premium, cross-section return can be written as a linear combination of factors with constant coefficients<sup>17</sup>. The Jagannathan and Wang [20] model significantly improves predictive power of CAPM.

Ludvigson and Lettau [22], on the other hand, resurrect the Consumption-Based CAPM (CCPAM). Along the line of Jagannathan and Wang [20], they examine a conditional version of CCPAM, in which the stochastic discount factor is expressed as a conditional or scaled factor model. They model time-variation in the coefficients by interacting consumption growth with an instrument, in particular, a

cointegrating factor  $\widehat{cay}$  - a cointegrating residual between consumption, asset(nonhuman) wealth, and labor income(all in log). A growing literature find that expected excess returns on aggregate stock market indice are predictable, suggesting that risk premium varies over time<sup>18</sup>. The parameters in the stochastic discount factor will then depend on investor's expectations of future excess return. Lettau and

Ludvigson demonstrate that  $\widehat{cay}$  drives time-variation in conditional expected return. The consumption cointegrating factor alone fails to capture variation of

average returns<sup>19</sup>. Although they show that the

interaction between  $\widehat{cay}$  and labor income growth or consumption growth can explain 70% variation of average return, it remains a difficult task to reconcile how this interaction term can make such a difference.

In this paper, we undertake the investigation of the CAPM by using a conditional market premium derived from an optimization-based model. Declining consumption volatility has been a plausible explanation for the declining equity premium. Bansal and Yaron [1] ( hereafter referred to as the BY model) justify the equity premium by assuming that consumption growth rate follows a stochastic volatility model. They show that the conditional equity premium is a linear function of conditional consumption and market return volatilities. Thereafore, we proceed to estimate two stochastic volatility models to test the validity of BY model. However, estimation methods of conditional volatility abound in the econometrics literature; for instance, the large class of Generalized Autoregressive Conditional Heteroskedasticity (GARCH) models. If the BY model is true, it should hold for various GARCH models. Then, the Fama-Macbeth approach is applied to explain cross-section average returns. Furthermore, the following null hypothesis will be tested: if the theoretical equity premium is adequate, it would render the instrumental variables redundant.

We find that the Bansal and Yaron theoretical premium significantly outperforms traditional CAPM using observed market premium. Using GARCH consumption and market volatility alone can explain 55% variation of cross-section return difference. Not only does it improve the Fama and French model, replacing the Bansal and Yaron premium, the Ludvigson and Lettau model also outperform the former. Moreover, various  $\chi^2$  tests reject the joint significance of Ludvigson and Lettau instrumental variables.

This paper is structured as follows. Section 2 presents the Bansal and Yaron model. We briefly describe the derivation of the theoretical market premium. Section 3 is devoted to model conditional volatilities. Two Stochastic Volatilities and three typical GARCH type volatilities are estimated: Generalized Autoregressive Conditional Heteroskedasticity (GARCH), Exponential GARCH and Threshold GARCH. The idea is that if the Bansal

---

<sup>17</sup> The proof can be found at the appendix of Jagannathan and Wang [20].

<sup>18</sup> see Campbell [7] and Lamont [21]

and Yaron premium can truly explain cross-section return differences, the result should be applied to various conditional volatility specifications. Section 4 explains the data and regression models. Section 5 reports the results and section 6 concludes.

## 2. Economic Model

We now consider the Bansal and Yaron [1] model. It shows that, if consumption and dividend growth rate contain a small long-run predictable component, consumption volatility is stochastic, and, if the representative household has Epstein and Zin preference, the asset and return premium will be a linear function of conditional consumption and market volatility. The euler condition is given by

$$E_t[\delta^\theta G_{t+1}^{-\frac{\theta}{\psi}} R_{a,t+1}^{-(1-\theta)} R_{i,t+1}] = 1 \quad (1)$$

where  $\delta$  is the discount factor,  $G_{t+1}$  is gross return of consumption,  $R_{a,t+1}$  is the gross return on an asset that delivers aggregate consumption as its dividends each period. As well-documented in the literature, this class of preference disentangles the relation between intertemporal elasticity of substitution

(IES) and risk aversion. The parameter  $\theta = \frac{1-\gamma}{1-\frac{1}{\psi}}$ ,

with  $\gamma \geq 0$  as the degree of risk aversion,  $\psi$  denotes IES. Campbell and Shiller [8] show that the log-linearized asset return can be expressed as

$$r_{a,t+1} = \kappa_0 + \kappa_1 z_{t+1} - z_t + g_{t+1} \quad (2)$$

where  $z_t = \log\left(\frac{P_t}{C_t}\right)$  is the log price-consumption ratio. The log-linearized first order euler condition is

$$m_{t+1} = \theta \log \delta - \frac{\theta}{\psi} g_{t+1} + (\theta-1)r_{a,t+1} \quad (3)$$

where  $m_{t+1}$  is the stochastic discount factor.

When  $\theta=1$ , then  $\gamma = \frac{1}{\psi}$ , and the above equation is pinned down to the case of CES utility function. Moreover, if  $\theta=1$  and  $\gamma=1$ , we get the standard case of log utility. In the spirit of neo-classical Real Business Cycle model (RBC), an exogenous i.i.d shock perturbs consumption and output from their steady paths. The system of shocks is

$$\begin{aligned} x_{t+1} &= \rho x_t + \varphi_e \sigma_t e_{t+1} \\ g_{t+1} &= \mu + x_t + \sigma_t \eta_{t+1} \\ g_{d,t+1} &= \mu_d + \phi x_t + \varphi_d \sigma_t u_{t+1} \\ \sigma_{t+1}^2 &= \sigma^2 + \nu_1 (\sigma_t^2 - \sigma^2) + \sigma_w w_{t+1} \\ e_{t+1}, \eta_{t+1}, w_{t+1} &: N(0,1) \end{aligned}$$

This system of equation suggests that consumption and dividend growth rates are driven by an unobservable process  $x_t$ , and the volatility of the latter exhibits mean-reversion but perturbed by an i.i.d shock. Bansal and Yaron [1] solve the log price-consumption ratio by method of undetermined coefficients, and find that

$$z_t = A_0 + A_1 x_t + A_2 \sigma_t^2 \quad (4)$$

$$A_1 = \frac{1-\frac{1}{\psi}}{1-\kappa_1 \rho}, \quad A_2 = \frac{0.5[(\theta-\frac{\theta}{\psi})^2 + (\theta A_1 \kappa_1 \varphi_e)^2]}{\theta(1-\kappa_1 \nu_1)}$$

An analogous coefficient for the price dividend ratio,  $A_{2,m}$  is derived in a similar fashion. There are two noteworthy features of this model. First, if  $\gamma$  and  $\psi$  are larger than 1, then  $\theta$  is negative, and a rise in volatility lowers the price-consumption ratio, since the intertemporal effect dominates the substitution effect. Second, the risk premium is a positive function of the volatility persistence parameter  $\rho$ ; meaning that the representative consumer dislikes a prolonged period of consumption shocks. After some algebra, the market premium in the presence of time-varying economic uncertainty takes the form:

$$E_t(r_{m,t+1} - r_{f,t}) = \beta_{m,e} \lambda_{m,e} \sigma_t^2 + \beta_{m,w} \lambda_{m,w} \sigma_w^2 - 0.5 \text{var}_t(r_{m,t+1}) \quad (5)$$

where  $\lambda_{m,e}$  is the price of risk, and  $\beta_{m,e}$  is the quantity of risk. The risk premium of any asset, given by CAPM, can be expressed as

$$E_t(r_{i,t+1} - r_{f,t}) = \rho + \beta_{m,e} \lambda_{m,e} \sigma_t^2 - 0.5 \text{var}_t(r_{m,t+1}) + \varepsilon_t \quad (6)$$

The BY model calls for estimation of two equations. Equation (5) states that long-run market risk premium is determined by conditional consumption and market return volatility. In particular, the cointegrating vector is  $(\beta_{m,e} \lambda_{m,e}, -0.5)$ . This paper focuses on equation (6), which explains cross-sectional return by conditional volatility.

The essence of the BY model is that persistent stochastic volatility can explain risk premium. Here we provide an empirical test, by regressing cross-sectional return against different variants of conditional

stochastic volatility. Choosing the best stochastic volatility model is not the purpose of this paper. Rather, we want to show that if equation (6) can be explained by some common GARCH and SV models, it should provide indirect support for the BY model. More importantly, it provides an alternative for the Fama-Macbeth model. While the independence of Fama-Macbeth factors is controversial, aggregate consumption and market return volatility should be uncorrected. Next section is devoted to the description of various conditional volatility models.

### 3. Volatility Modelling

Since the literature on conditional volatility is well-documented, The readers can refer to Bollerslev, Chou and Kroner [5], Bollerslev, Engle and Nelson [6] for a survey of the GARCH processes. We will also use the Exponential GARCH and Threshold GARCH to model asymmetry. Stochastic Volatility (SV) models which are reviewed in, for example, Taylor [27], Ghysels, Harvey and Renault [16] have been increasingly recognized as a viable alternative to GARCH models, although the latter are still the standard in empirical applications.

Most SV models are expressed in continuous time. The following models can be regarded as the discrete time analogue of the continuous time model used in papers on option pricing (see Hull and White [19]). The discrete SV model is intrinsically nonlinear. The parameters can be estimated by approximation methods or by using exact methods based on Monte-Carlo simulation which are subject to sampling error.

The first SV model takes the following form (see Harvey, Ruiz and Shephard [18], hereafter hrs):

$$\begin{aligned} r_t &= \sigma_t \varepsilon_t \\ h_t &= \ln \sigma_t^2 = \gamma + \phi h_{t-1} + \eta_t \\ \eta_t &: N(0, \sigma_\eta^2) \end{aligned}$$

$r_t$  is the continuously compounded return of an asset.  $h_t$  is always positive and takes on an AR(1) process.  $\varepsilon_t$  and  $\eta_t$  are assumed to be two independent processes. The process above is nonlinear, which can be transformed into a linear one by appropriate change of variable.

We define  $y_t = \ln r_t^2$ . It can be shown that  $E(\ln \varepsilon_t^2) = -1.27$  and  $var(\ln \varepsilon_t^2) = \frac{\pi^2}{2}$ . An

unobserved component state space representation for  $y_t$  has the form

$$y_t = -1.27 + h_t + \xi_t, \quad \xi_t : N(0, \frac{\pi^2}{2}) \quad (7)$$

$$h_t = \gamma + \phi h_{t-1} + \eta_t, \quad \eta_t : N(0, \sigma_\eta^2) \quad (8)$$

$$E[\xi_t \eta_t] = 0 \quad (9)$$

The second SV is estimated by Durbin and Koopman [12] model. In high frequency data analysis, the model is usually specified as:

$$r_t = \sigma \exp(\frac{1}{2} \theta_t) \varepsilon_t, \quad \varepsilon_t : N(0, 1) \quad (10)$$

$$h_t = \ln \sigma_t^2 = \gamma + \phi h_{t-1} + \eta_t, \quad \eta_t : N(0, \sigma_\eta^2)$$

where  $\sigma$  denotes average volatility. These five volatility models are estimated and then used as input for Fama-MacBeth estimation.

### 4. The Conditional Equity Premium

This section depicts the difficulty of estimating conditional market premium and some plausible ways to resolve such problems. In many variants of CAPM, the basic pricing equation is given by

$$p_t = E_t[m_{t+1} x_{t+1}] \quad (11)$$

where  $m_{t+1}$  represents the stochastic discount factor,  $x_{t+1}$  is the payoff,  $E_t[.]$  is the expectation conditional on the market-wide time-t information set. The stochastic factor can be derived by CCAPM or Merton's Intertemporal CAPM (ICAPM), and it is linear in market portfolio return. However, only if the payoffs and discount factors were independent and identically distributed over time, could conditional expectations be the same as unconditional expectations. The conditional stochastic pricing equation can be estimated by the General Method of Moments (GMM), for instance Hansen and Singleton [17].

Since the beta pricing model and stochastic factor representation are equivalent, Jagannathan and Wang [20] estimate a single beta model with respect to aggregate wealth or market portfolio. The dynamics of the model comes from the time-varying behavior of both beta and market risk premium with the business cycle. The single beta model becomes an unconditional multi-beta model once the parameters of the discount



factor are assumed to be a linear function of a list of macroeconomic variables.

The conditional CAPM states that for each asset  $i$  and in each period  $t$ ,

$$E[R_{i,t} | \mathbf{I}_{t-1}] = \gamma_{0t-1} + \gamma_{1t-1} \beta_{it-1}, \quad (12)$$

where  $\gamma_{0t-1}$  is the zero-beta rate,  $\gamma_{1t-1}$  is the conditional market risk premium, and  $\beta_{it-1}$  is the conditional beta of asset  $i$ . They derive implications of the unconditional asset-pricing model from the conditional version of CAPM. Taking unconditional expectation on both sides and using the law of iterated expectation,

$$E[R_{it}] = \gamma_0 + \gamma_1 \bar{\beta}_i + Cov(\gamma_{1t-1}, \beta_{it-1}) \quad (13)$$

where

$$\gamma_0 = E[\gamma_{0t-1}], \gamma_1 = E[\gamma_{1t-1}], \bar{\beta}_i = E[\beta_{it-1}]$$

If the covariance between conditional beta of asset  $i$  and the conditional market risk premium is zero for every arbitrarily chosen asset  $i$ , then the above equation is equivalent to the static CAPM. Denote the yield spread between BAA- and AAA-rated bonds by

$R_{t-1}^{prem}$  as a proxy for the market risk premium, let  $R_t^{vw}$  be the return of stock market as a proxy for return on the portfolio of aggregate wealth, and  $R_t^{labor}$  be the labor return as a proxy for human income. Suppose the corresponding betas are  $\beta_i^{prem}, \beta_i^{vw}, \beta_i^{labor}$ , with their Theorem 1 and corollary 2, Jagannathan and Wang [20] show that

$$E[R_{it}] = c_0 + c_{vw} \beta_i^{vw} + c_{prem} \beta_i^{prem} + c_{labor} \beta_i^{labor} \quad (14)$$

where  $c_0, c_{vw}, c_{prem}, c_{labor}$  are constants. The above unconditional beta pricing model is then estimated using GMM. They argue that GMM requires much weaker statistical assumptions.

Ludvigson and Lettau [22] handle the problem by using an instrumental variable. Since there exists a beta representation if and only if the stochastic discount factor is linear in the mean-variance frontier portfolio; and the beta pricing model implied that the stochastic discount factor is linear in the factors that generate betas, the discount factor can always be expressed as:

$$m_{t+1} = a_t + b_t \Delta c_{t+1} \quad (15)$$

where  $\Delta c_{t+1}$  denotes change of consumption growth, which is the single fundamental factor in CCAPM. Note that the coefficients are time-varying.

Following Cochrane [10], Ludvigson and Lettau assumes that

$$a_t = \gamma_0 + \gamma_1 z_t \quad (16)$$

$$b_t = \eta_0 + \eta_1 z_t$$

Combing equation (15) and (16),

$$m_{t+1} = \gamma_0 + \gamma_1 z_t + \eta_0 \Delta c_{t+1} + \eta_1 z_t \Delta c_{t+1} \quad (17)$$

$z_t$  is an instrumental variable and their choice  $\widehat{cay}$  is a cointegrating factor of consumption growth and labor income. Equation (17) is the scaled multifactor model, which remarkably holds in an unconditional sense. For instance, the standard CAPM is estimated by

$$E_t(r_{i,t+1} - r_{f,t}) = \rho_0 + \rho_1 \widehat{cay}_t + \rho_2 E_t(r_{m,t+1} - r_{f,t}) + \rho_3 \widehat{cay}_t \cdot E_t(r_{m,t+1} - r_{f,t})$$

where  $r_{m,t+1} - r_{f,t}$  is market excess return. Now, replace the conditional  $r_{m,t+1} - r_{f,t}$  with the BY premium. The benchmark model is:

$$E_t(r_{i,t+1} - r_{f,t}) = \gamma_0 + \beta_1 \lambda_c \sigma_{c,t}^2 + \beta_2 \lambda_m \sigma_{m,t+1}^2 + e_t \quad (18)$$

where  $\sigma_{c,t}^2$  and  $\sigma_{m,t+1}^2$  are conditional consumption and market volatilities respectively. The Fama and French model now has four factors:

$$E_t(r_{i,t+1} - r_{f,t}) = \gamma_0 + \beta_1 \lambda_c \sigma_{c,t}^2 + \beta_2 \lambda_m \sigma_{m,t+1}^2 + \beta_3 smb_t + \beta_4 hml_t + e_t \quad (19)$$

The Ludvigson and Lettau conditional scale factor model can be expressed as

$$E_t(r_{i,t+1} - r_{f,t}) = \gamma_0 + \beta_1 \lambda_c \sigma_{c,t}^2 + \beta_2 \lambda_m \sigma_{m,t+1}^2 + \beta_3 \lambda_z \widehat{cay}_t + \beta_4 \lambda_{z,c} \widehat{cay}_t \cdot \sigma_{c,t}^2 + \beta_5 \lambda_{z,m} \widehat{cay}_t \cdot \sigma_{m,t}^2 \quad (20)$$

Other regression models are reported in table 1.3-1.5. In the next section, we will examine whether the BY market premium can explain the cross section of expected returns. The Ludvigson and Lettau scale factor model will be augmented with the BY premium. Two hypotheses will be tested. 1. Is there any statistical evidence that the stochastic consumption volatility can explain the equity premium puzzle? 2. If the BY instrumental risk premium is correct, it should render the instrumental variables redundant.

## 5. Results

### 5.1 Conditional consumption and market volatilities

The consumption and labor income data can be found at Ludvigson and Lettau's website<sup>20</sup>. The Fama-French factors, market return and risk free rate can be downloaded from Fama's website<sup>21</sup>. We choose the 25 Fama-French portfolio returns as the dependent variables. These data are value-weighted returns for the intersection of five size portfolios and five book-to-market equity (BE/ME) portfolios on the New York Stock Exchange, the American Stock Exchange, and NASDAQ stocks in Compustat. The portfolios are constructed at the end of June, and market equity is the market capitalization at the end of June. The ratio BE/ME is book equity at the end of December of the prior year. This procedure is repeated for every calendar year from January, 1962 to October, 2010 which is the sample period.

The instrumental variable  $\widehat{cay}$  is a cointegrating factor of consumption growth and labor income. Ludvigson and Lettau [22] contends that this factor sums up information about investor's expected return, and outperforms such future return predictors as price-dividend ratio and equity-price ratio. Ludvigson and

Lettau [22] further argues that  $\widehat{cay}$  can be used to explain cross-sectional returns. Their findings include: 1) The traditional CAPM fails miserably in explaining cross-sectional return; 2) Fama-French model is a resounding success; 3) adding  $\widehat{cay}$  into CAPM only slightly improve the model fit; 4) but using  $\widehat{cay}$  as an instrument, interacting it with market risk premium and labor income growth significantly improves the model. In this paper, we will demonstrate that by replacing observed market premium with conditional consumption and market return volatilities, even without interacting with labor income, the model predictive power is comparable to that of Fama and French. Before proceeding to the regression result, the estimated conditional volatilities will be examined.

Consumption series being more persistent than that of market return, is well-documented in the literature.

Not surprisingly, the order of GARCH type consumption model is relatively higher. Still, most of the series can be estimated with GARCH(1,1), and the residuals exhibit no serial correlation. Figure 1.1 - figure 1.5 report the consumption volatility series. The range of GARCH type models is 0.35 - 0.7% per quarter, consistent with the observed data. Consumption is more volatile during mid 1970's, early 1980's and early 1990's, getting more stable after 1995. While GARCH and TGARCH series are relatively jagged, showing less clustering. The downward trend of EGARCH consumption series is very obvious. The HRS stochastic volatility series is very irregular during the first few years, and then smooth out later on. In contrast with GARCH models, both SV models predict a smooth transition of consumption volatility. However, the consumption volatility is slightly over-predicted. For instance, most of the time, the HRS quarterly volatility ranges from 0.8 to 1.2%.

The market volatility series can be found in figure 2.1 - 2.5. The GARCH type and HRS SV models predict very jagged series. The market was more volatile during the mid 1970's and early 2000's. However, the HRS model significantly over-predicts; for instance, the market volatility in 1976 was almost 60%, defying the observed data. In contrast, the Durbin-Koopman SV series is overly smooth, and often, under-predicts market volatility. The poor performance can be reconciled by the fact that, SV series follows random walk pattern. It predicts change of volatility in infinitely short period of time. However, most quarterly series exhibits high persistence, which is better captured by GARCH type models.

### 5.2 Fama-French style regressions

The unconditional models can be consistently estimated by the cross-sectional regression method proposed by Black, Jensen, and Scholes [3], and Fama and MacBeth[15]. We estimate equation (18) and its variants by the Fama-MacBeth[15] approach. The first step is time series regression of each portfolio return against the BY premium and other scale factors. The second stage is cross-section regression for each quarter. The Fama-Macbeth estimates are simply the time average of cross-sectional estimates. Cochrane [10] proves that if the betas do not vary over time and if the errors in the time series regression are cross-sectionally correlated but not correlated over time, the Fama-Macbeth estimate of risk price is identical to the pure cross section OLS regression estimate. The Fama-Macbeth standard errors are identical to the cross-sectional standard errors, corrected for cross-sectional residual correlation.

<sup>20</sup> <http://www.econ.nyu.edu/user/ludvigsons/>

<sup>21</sup> [http://mba.tuck.dartmouth.edu/pages/faculty/ken.french/data\\_library.html](http://mba.tuck.dartmouth.edu/pages/faculty/ken.french/data_library.html)

Table 1.1-1.5 reports the Fama-French style regression results<sup>22</sup>. We compute the usual t statistics corrected for cross-section heteroskedasticity, Newey-Wesley standard error, and then both adjusted for the Shanken small sample standard error<sup>23</sup>. The computed t-statistics turns out to be very sensitive to the error correction method, rendering comparison difficult. The Shanken correction is directly related to the magnitude of each  $\lambda$ , coefficient estimate and inversely related to the factor volatility. The Shanken correction factor is larger when comparing to Lettau and Ludvigson's results, due to low factor volatility. It should be noted that the standard CAPM predicts a zero intercept, but the models in this paper do not. It can be easily verified by equation (6). In fact, the intercepts in most models are positive and significant.

Following Jagannathan and Wang [20], and Ludvigson and Lettau [22],  $R^2$  is used as an informal and intuitive measure, which shows the fraction of the cross-sectional variation of average returns that can be explained by the model. When using  $R^2$  as a crude measure of goodness of fit, the GARCH type models outperform the SV models in all cases. Coefficients of the former model are also more likely to be correct. It means that either stochastic consumption volatility fails to explain equity premium, or that stochastic volatility fails to capture trending behavior in low frequency data. While quarterly data in general exhibits trend behavior, high-frequency data does not. Stochastic volatility is usually modelled to mimic return change in an infinitely small time horizon, which is believed to be trendless. Hence, GARCH type models are able to capture the trend behavior of quarterly time series.

Table 1.1 presents the traditional CAPM regression result, and we see that the standard CAPM fails miserably. The  $R^2$  is only 0.055. Not only is the coefficient of risk premium insignificant, its sign is incorrect. However, our GARCH type and SV models show significant improvement. The model predicts a positive consumption volatility and negative market return volatility coefficient. Our result, is by large consistent with model prediction. The  $R^2$  range is 0.14 - 0.55. The best fitting model is GARCH, with  $R^2$  equal to 0.55, significant consumption volatility coefficients using usual t statistics. TGARCH model prediction is similar, though  $R^2$  is slightly lower, the

size of coefficients are larger, and the market volatility coefficient is significant at  $\alpha$  equal to 10%.

The Fama and French result is replicated in table 1.2. We find that  $R^2$  is around 80% and only HML and the intercept are significant-which is the same as Lettau and Ludvigson [22] and Fama and French [14]. However, by using data over a longer period, the sign of risk premium is no longer correct. When replacing market premium with consumption and market volatility, the same pattern is observed. After adjusting for small sample bias, HML coefficient is still significant, but the sign of consumption volatility is incorrect. The coefficient of EGARCH and Durbin-Koopman consumption coefficients are significant at  $\alpha$  equal to 10%. More importantly, all GARCH and SV models slightly outperform the standard Fama-French model. The  $R^2$  of EGARCH is 0.84, 5% higher than that of Fama-French.

Ludvigson and Lettau[22] find that including  $\widehat{cay}$  and its interaction with risk premium does not improve predictive power of their model. The same result is replicated in table 1.3 with longer span of data. The

$R^2$  is 0.06 when the scale factor  $\widehat{cay}$  interact with market return. All coefficients are insignificant after adjusting for small sample error.

Table 1.4 shows that the forecasting variable  $\widehat{cay}$  fails to capture cross-section returns difference. The  $R^2$  is as low as 0.08 and the sign of market return coefficient remains incorrect. We find that the coefficient signs of GARCH models are all correct. An interesting finding is that EGARCH model performance is greatly enhanced, once  $\widehat{cay}$  enters the equation as a separate variable. The  $R^2$  of EGARCH is as high as 74%, increasing three-fold when compared to table 1.3.

The full Lettau and Ludvigson scaled factor model result is reproduced in table 1.5, in which the model is augmented with labor income growth and its interaction with  $\widehat{cay}$ . The  $R^2$  is as high as 0.71, and further increases once market premium is replaced by consumption and market return volatility. Most of the coefficients have the correct sign. The consumption and market volatility coefficients of EGARCH are individually and jointly significant after adjusting for Shanken standard error. The  $R^2$  is highest among all regression models in this paper.

Table 2.1-2.5 report the joint hypothesis testing of theoretical premium and the interaction terms,

<sup>22</sup> For an exposition of the estimation, see Fama and Macbeth[15].

<sup>23</sup> The quantity of risk i.e.,  $\beta$  is a generated series from time series regression. Thus the OLS standard error is incorrect.

corresponding to tables 1.1-1.5. The  $\chi^2$  statistics are corrected for cross-section heteroskedasticity, Newey-Wesley standard error, and then adjusted both for Shanken small sample standard error. Again, the adjustment for small sample bias is larger than that of Lettau and Ludvigson, due to small factor variance. Table 2.1 shows that the theoretical premium is jointly significant in GARCH, TGARCH and HRS models.

Once  $\widehat{cay}$  is used as an instrument, even EGARCH premium becomes significant (table 2.3). Ludvigson

and Lettau[22] fail to show significance of  $\widehat{cay}$  and its interaction terms, but they are jointly significant. We demonstrate that, once the theoretical conditional risk premium is added to the model, it renders all instrumental variables ( $\widehat{cay}$  and labor income growth rate) and their interaction terms insignificant. This result lends support to conditional consumption and market volatility as a reliable measure of conditional risk premium.

For full scaled model, as shown in table 2.5, the volatility and interaction coefficients of EGARCH are jointly significant. We have seen that this model has the highest  $R^2$ . Therefore, it can be concluded that EGARCH is the best fitting model in this paper. Most importantly, the declining EGARCH consumption volatility is consistent with declining equity premium in recent decades. Hence, while Bansal and Yaron [1] explain the declining premium by calibration, we provide statistical evidence to support their claim.

## 6. Conclusion

An optimization-based regression model is estimated in this paper. We propose estimating the conditional equity premium directly by conditional consumption and market return volatility. Most of the coefficient signs are correct. If  $R^2$  is used as criteria, the volatility models outperform standard CAPM. The EGARCH model, once augmented with Lettau and Ludvigson's scaled factor, outperforms all previous models. In various  $\chi^2$  tests, it is shown that the theoretical premium renders all instrumental variables redundant, providing indirect evidence for BY model. However, robustness remains an issue. While Lettau

and Ludvigson [22] fail to justify why only  $\widehat{cay}$  interacting labor income growth can explain return differences, this model has a hard time explaining why the EGARCH model performance greatly enhance

once  $\widehat{cay}$  is introduced.

## 6. References

- [1] Bansal, R., and Yaron, A., 2004, *Risks for Long-Run: A Potential Resolution of Asset Pricing Puzzles*, Journal of Finance, **59**: 1481-1509
- [2] Banz, R., 1981 *The Relation between Return and Market Value of Common Stocks*, Journal of Financial Economics, **9**:3-18
- [3] Black, F., Jensen, M, C., and Scholes, M, 1972 *The capital asset pricing model. Some empirical tests*, in Jensen, M., Ed: Studies in the Theory of Capital Markets, Pareger, New York, pp. 79-121.
- [4] Bollerslev, T., 1986 *Generalized Autoregressive Conditional Heteroskedasticity*, Journal of Econometrics, **31**:307-327
- [5] Bollerslev, T., Chou, R., and Kroner, K, 1992 *Arch Modeling in Finance: A Review of the Theory and Empirical Evidence*, Journal of Econometrics, **52**: 5-59
- [6] Bollerslev, T., Engle, R., and Nelson, D., 1994 *Arch Models*, In Engle, R., and McFadden, D (Eds) Handbook of Econometrics, Volume 4:2959-3038. Elsevier Science, Amsterdam.
- [7] Campbell, J. Y., 1991 *A Variance Decomposition for Stock Returns*, Economic Journal, **101**:157-79
- [8] Campbell, J., and Shiller, R, 1988 *The Dividend-Price Ratio and Expectations of Future Dividends and Discount Factors*, Review of Financial Studies, **1**: 195-227
- [9] Chen, N., Roll, R., and Ross, S, 1986 *Economic Forces and the Stock Market*, *The Journal of Business*, **59**(3):383-404
- [10] Cochrane, J., 1996 *A Cross-Sectional Test of Investment-Based Asset Pricing Model*, Journal of Political Economy, **104**:572-621
- [11] De Jong, P., and Shephard, N 1995 *The Simulation Smoother for Time Series Models*, Biometrika **82**:339-50
- [12] Durbin, J., Koopman, S., 1997 *Monte Carlo Maximum Likelihood Estimation of Non-Gaussian State Space Model*, Biometrika **84**:669-84

- [13] Engle, R., 1982 *Autoregressive Conditional Heteroskedasticity with Estimates of the Variance of United Kingdom Inflation*, *Econometrica* **50**: 987-1008
- [14] Fama, E., and French K, 1993 *Common Risk Factors in the Returns on Stocks and Bonds*, *Journal of Financial Economics*, **33**:3-56
- [15] Fama, E., and Macbeth, J., 1973 *Risk, Return and Equilibrium: Empirical Tests*, *Journal of Political Economy*, **81**:607-36
- [16] Ghysels, E., Harvey, A., and Renault, E, 1996 *Stochastic Volatility*, in Maddala, G., and Rao, C(Eds), *Handbook of Statistics, Volume 14, Statistical Methods in Finance*, pp: 119-191, North-Holland, Amsterdam.
- [17] Hansen, L., and Singleton, K., 1982, *Generalized Instrumental Variables Estimation of Nonlinear Rational Expectations Models*, *Econometrica* **50**(5):1269-86
- [18] Harvey, A., Ruiz, E., and Shephard, N., 1994 *Multivariate Stochastic Variance Models*, *Review of Economic Studies*, **61**:247-64
- [19] Hull, J., and White, A., 1987 *The Pricing of Option on Assets with Stochastic Volatilities*, *Journal of Finance* **42**:281-300.
- [20] Jagannathan, R., and Wang Z, 1996 *The Conditional CAPM and the Cross-Section of Expected Returns*, *The Journal of Finance*, **51**(1):3-53
- [21] Lamont O., *Earnings and Expected Returns*, *Journal of Finance*, **53**:1563-87
- [22] Ludvigson, S., and Lettau, M., 2002, *Resurrecting (C)CAPM: A Cross-Sectional Test When Risk Premia are Time-Varying*, *Journal of Political Economy*, **109**(61): 1238-1287
- [23] Nelson, D., 1991 *Conditional Heteroskedasticity in Asset Returns: A New Approach*, *Econometrica*, **59**:347-370
- [24] Roll, R., 1977 *A Critique of the Asset Pricing Theory's Test: Part I: On Past and Potential Testability of the Theory*, *Journal of Financial Economics*, **4**(March):129-76.
- [25] Shanken, J., 1992 *On the Estimation of Beta-Pricing Models*, *Review of Financial Studies*, **5**:1-34
- [26] Shephard, N., and Pitt, M., 1997 *Likelihood Analysis of Non-Gaussian Measurement Time Series*, *Biometrika* **84**: 653-67
- [27] Taylor, S., 1999 *Modeling Stochastic Volatility: A Review and Comparative Study*, *Mathematical Finance* **4**:183-204

## Appendix

Figure 1.1 GARCH Consumption Volatility

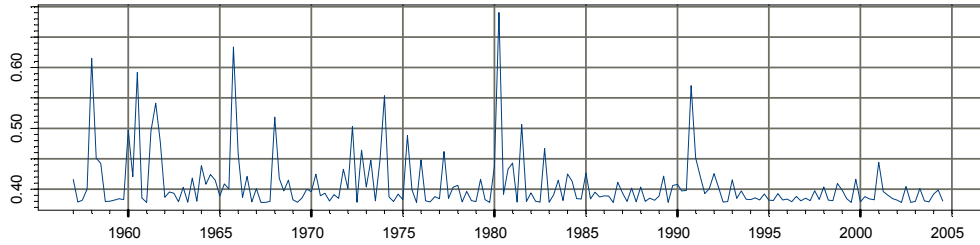


Figure 1.2 EGARCH Consumption Volatility

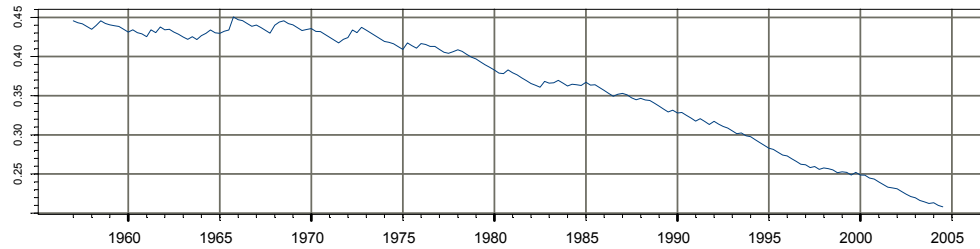


Figure 1.3 TGARCH Consumption Volatility

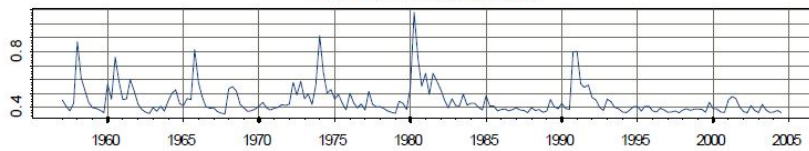


Figure 1.4 HRS Consumption Stochastic Volatility

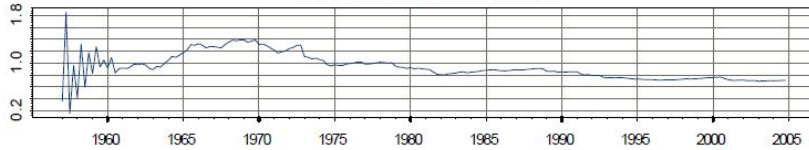


Figure 1.5 Durbin Koopman Maximum Likelihood Consumption Stochastic Volatility

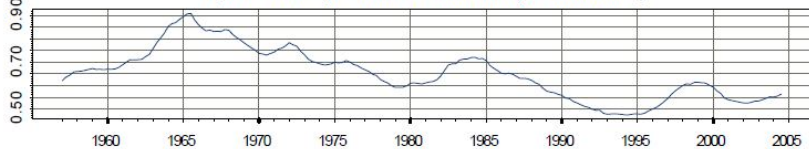


Table 1.1 Fama a-Mach et al Regressions Using 25 Fama a-French Portfolios

CAPM					
Volatility Model	Intercept	$\frac{c}{t}$	$\frac{um}{t}$	$R_{um}$	$R^2$
	4.4 (5.85)* (5.82)** (4.96)*** (4.93)***			-0.8 (-1.18) (-0.87) (-0.74) (-0.64)	0.055
GARCH	3.53 (7.33) (3.23) (5.85) (2.6)	0.094 (8.4) (3.7) (3.67) (1.6)	-0.72 (-2.6) (-1.3) (-1.57) (-0.69)		0.55
EGARCH	4.06 (9.08) (8.08) (6.9) (6.14)	-0.02 (-0.69) (-0.61) (-1.42) (-1.21)	-0.63 (-1.68) (-1.44) (-1.14) (-1.0)		0.14
TGARCH	3.75 (8.68) (4.52) (6.84) (3.56)	0.14 (5.78) (2.97) (2.81) (1.45)	-1.94 (-3.49) (-1.8) (-2.28) (-1.18)		0.54
HRS	3.13 (15.44) (9.72) (5.13) (3.24)	-0.26 (-2.13) (-1.34) (-2.94) (-1.85)	4.0 (1.55) (0.97) (0.85) (0.54)		0.21
DK	3.6 (26.93) (16.1) (5.09) (3.04)	0.055 (0.76) (0.45) (1.33) (0.79)	1.62 (2.72) (1.62) (2.53) (1.51)		0.2

Table 1: \*t statistics adjusted for cross-section heteroskedasticity; \*\*adjusted for Shanken standard error; \*\*\*newey-west adjusted standard error, \*\*\*\*newey-west and Shanken adjusted standard error



Table 1.2 Fama  $\alpha$ -M acbethe Regressions Using 25 Fama  $\alpha$ -French Portfolios

Volatility Model	Fama $\alpha$ -French Factors						$R^2$
	Intercept	$\alpha$ t	$\alpha_{MKT}$ t	$R_{UM}$	$SM L$	$HML$	
	4.02			-1.19	0.61	1.33	0.79
	(4.23)			(-1.28)	(3.59)	(7.04)	
	(4.05)			(-1.04)	(1.38)	(2.97)	
	(3.82)			(-0.98)	(1.47)	(3.23)	
	(3.65)			(-0.84)	(1.03)	(2.26)	
GARCH	3.59	-0.014	-0.45		0.65	1.29	0.8
	(9.65)	(-0.97)	(-1.43)		(4.18)	(7.49)	
	(8.4)	(-0.83)	(-1.2)		(1.5)	(2.9)	
	(6.86)	(-1.03)	(-1.49)		(1.56)	(3.14)	
	(5.98)	(-0.88)	(-1.26)		(1.04)	(2.08)	
EGARCH	3.04	-0.04	-0.28		0.67	1.26	0.84
	(13.48)	(-2.3)	(-0.79)		(5.5)	(8.63)	
	(11.3)	(-1.88)	(-0.64)		(1.6)	(2.8)	
	(5.84)	(-3.04)	(-0.65)		(1.63)	(3.04)	
	(4.88)	(-2.47)	(-0.53)		(1.05)	(1.96)	
TGARCH	3.31	-0.03	-0.31		0.62	1.31	0.79
	(12.8)	(-0.71)	(-0.51)		(3.8)	(6.76)	
	(11.5)	(-0.64)	(-0.45)		(1.4)	(2.9)	
	(6.74)	(-0.9)	(-0.49)		(1.51)	(3.17)	
	(6.19)	(-0.81)	(-0.44)		(1.03)	(2.17)	
HRS	3.05	-0.08	-1.97		0.64	1.33	0.81
	(15.0)	(-1.03)	(-0.67)		(4.27)	(7.33)	
	(13.2)	(-0.9)	(-0.6)		(1.5)	(2.9)	
	(5.54)	(-1.49)	(-1.09)		(1.56)	(3.23)	
	(4.87)	(-1.27)	(-0.92)		(1.04)	(2.16)	
DK	3.06	-0.05	-0.33		0.69	1.3	0.82
	(15.45)	(-1.57)	(-0.74)		(4.72)	(7.86)	
	(13.0)	(-1.3)	(-0.6)		(1.6)	(2.9)	
	(5.65)	(-2.29)	(-0.9)		(1.71)	(3.16)	
	(4.74)	(-1.85)	(-0.74)		(1.1)	(2.05)	



Table 1.3 Firm  $\alpha$ -M acbet Regressions Using 25 Firm  $\alpha$ -French Portfolios

Volatility Model	CAPM with $\text{cov}$ as Instrument			Firm Factors $t-1$			$R^2$	
	Intercept	$\frac{c}{t}$	$\frac{um}{t}$	$R_{um}$	$\frac{c}{t}$	$\frac{um}{t}$		$R_{um}$
	4.72			-1.08			-0.13	0.06
	(2.78)			(-0.68)			(-0.21)	
	(2.7)			(-0.63)			(-0.2)	
	(6.13)			(-1.14)			(-0.46)	
	(6.05)			(-0.95)			(-0.43)	
GARCH	4.1	0.08	-1.43		0.003	0.05		0.62
	(6.6)	(6.19)	(-2.86)		(1.12)	(1.03)		
	(2.7)	(2.5)	(-1.17)		(0.46)	(0.42)		
	(7.73)	(3.25)	(-4.0)		(1.82)	(1.52)		
EGARCH	3.19	1.34	-1.64		0.75	0.62		0.25
	(3.19)	(1.34)	(-1.64)		(0.75)	(0.62)		
	(4.17)	(-0.043)	(-1.62)		(-0.13)	(-0.52)		
	(5.01)	(-1.32)	(-1.92)		(-0.13)	(-0.52)		
TGARCH	3.7	0.1	-2.65		0.006	0.08		0.63
	(9.48)	(2.25)	(-3.46)		(1.82)	(1.56)		
	(4.3)	(1.03)	(-1.57)		(0.83)	(0.7)		
	(6.35)	(1.99)	(-4.15)		(2.87)	(2.04)		
HRS	2.91	0.91	-1.89		1.31	0.93		0.49
	(2.91)	(0.91)	(-1.89)		(1.31)	(0.93)		
	(4.2)	(-0.08)	(3.78)		(-1.17)	(0.32)		
	(7.05)	(-0.68)	(3.78)		(-1.17)	(0.32)		
DK	3.83	0.07	1.52		-0.003	-0.03		0.23
	(13.29)	(1.11)	(2.49)		(-0.63)	(-0.62)		
	(7.9)	(0.66)	(1.48)		(-0.37)	(-0.36)		
	(6.06)	(1.96)	(2.93)		(-1.27)	(-0.03)		
	(3.6)	(1.16)	(1.73)		(-0.74)	(-0.62)		

Table 1.4 Firm a-M acb eth Regressions Using 25 Firm a-French Portfolios

Volatility	CAPM with		cay and cay as		Instrument		$R_2$		
	Intercept	$cay_t$	$c_t$	$um_t$	$R_{um}$	$cay.Factor_{t-1}$			
						$c_t$	$um_t$	$R_{um}$	
	4.75 (3.06) (2.7)	-0.006 (-0.8) (-0.72)			-1.08 (-0.74) (-0.62)			-0.02 (-0.36) (-0.32)	0.08
	(6.16) (5.55)	(-1.47) (-1.29)			(-1.14) (-0.89)			(-0.75) (-0.65)	
GARCH	4.01 (6.35) (2.76) (7.42) (3.22)	0.006 (1.02) (0.44) (1.64) (0.71)	0.08 (6.69) (2.9) (3.2) (1.39)	-1.4 (-2.8) (-1.2) (-4.0) (-1.73)		0.0023 (0.97) (0.42) (1.56) (0.67)	0.04 (0.93) (0.4) (1.36) (0.59)		0.62
EGARCH	1.4 (3.1) (1.35) (2.06) (0.9)	0.002 (0.36) (0.16) (0.39) (0.17)	-0.03 (-1.77) (-0.76) (-2.35) (-1.0)	-1.08 (-2.46) (-1.06) (-2.31) (-0.99)		-0.0006 (-0.51) (-0.22) (-0.56) (-0.24)	-0.02 (-0.73) (-0.32) (-0.67) (-0.29)		0.74
TGARCH	3.06 (7.59) (3.6) (5.19) (2.5)	0.005 (1.06) (0.5) (1.23) (0.58)	0.008 (0.19) (0.09) (0.22) (0.1)	-2.56 (-4.21) (-1.97) (-4.08) (-1.91)		0.001 (0.48) (0.23) (0.57) (0.27)	0.0004 (0.01) (0.005) (0.01) (0.0052)		0.73
HRS	4.13 (4.14) (2.6) (5.59) (3.5)	-0.007 (-1.11) (-0.72) (-1.66) (-1.04)	-0.09 (-0.66) (-0.41) (-1.64) (1.15)	7.0 (2.78) (1.71) (1.86) (-1.02)		-0.007 (-1.16) (-0.68) (-1.7) (-1.0)	0.01 (0.27) (0.16) (0.32) (0.19)		0.49
DK	3.6 (13.14) (6.02) (6.03) (2.8)	-0.015 (-2.09) (-0.95) (-2.69) (-1.23)	0.056 (0.87) (0.4) (1.72) (0.78)	1.33 (2.24) (1.03) (2.71) (1.23)		-0.008 (-1.85) (-0.85) (-2.0) (-1.19)	-0.08 (-1.67) (-0.76) (-2.16) (-0.99)		0.32

Table 1.5 Firm  $\alpha$ -Mach  $\sigma$ th Regressions Using 25 Firm  $\alpha$ -French Portfolios

Ludvigson and Lettau's Scaled Models

Volatility	Intercept	Cov. Factors $t-1$								$R^2$	
		$\text{cov}$	$\frac{c}{t}$	$\frac{um}{t}$	$R_{um}$	$y$	$\frac{c}{t}$	$\frac{um}{t}$	$R_{um}$		$y$
	6.6 (9.47) (3.7) (6.4) (2.45)	-0.004 (-0.69) (-0.27) (-1.11) (-0.43)			-3.64 (-5.32) (-3.6) (-3.11) (-1.18)	0.01 (2.56) (0.99) (3.07) (1.19)			-0.08 (-2.81) (-1.08) (-2.26) (-0.87)	0.0002 (3.33) (1.3) (3.89) (1.5)	0.71
GARCH	3.7 (6.53) (3.3) (6.69) (3.4)	0.005 (0.83) (0.42) (1.36) (0.7)	0.04 (1.9) (0.96) (2.1) (1.06)	-1.3 (-2.87) (-1.45) (-3.77) (-1.9)		0.003 (0.76) (0.38) (1.37) (0.69)	0.002 (0.67) (0.34) (1.16) (0.58)	0.033 (0.64) (0.33) (1.03) (0.52)		0.0001 (1.73) (0.88) (2.99) (1.51)	0.67
EGARCH	2.42 (5.19) (2.22) (3.68) (1.57)	-0.005 (-0.89) (-0.38) (-1.32) (-0.56)	-0.07 (-5.2) (-2.2) (-4.17) (-1.76)	-1.46 (-4.35) (-1.84) (-2.71) (-1.15)		-0.003 (-0.78) (-0.33) (-1.06) (-0.45)	-0.002 (-0.98) (-0.42) (-1.48) (-0.63)	-0.06 (-1.5) (-0.67) (-1.97) (-0.84)		0.00008 (1.78) (0.76) (2.43) (1.03)	0.83
TGARCH	3.06 (6.41) (2.96) (4.56) (2.1)	0.004 (0.55) (0.25) (0.88) (0.4)	-0.02 (-0.33) (-0.15) (-0.48) (-0.22)	-2.58 (-4.23) (-1.93) (-3.59) (-1.65)		0.002 (0.29) (0.14) (0.46) (0.21)	0.0004 (0.14) (0.06) (0.2) (0.09)	-0.013 (-0.25) (-0.12) (-0.37) (-0.17)		0.0001 (1.74) (0.8) (2.56) (1.17)	0.74
HRS	2.7 (4.8) (2.16) (3.95) (2.0)	-0.006 (-1.08) (-0.55) (-1.38) (-0.69)	-0.2 (-2.07) (-1.04) (-3.02) (-1.51)	-0.52 (-0.16) (-0.08) (-0.23) (-0.11)		0.003 (1.64) (0.82) (1.26) (0.63)	-0.005 (-0.9) (-0.45) (-1.27) (-0.64)	-0.03 (-0.69) (-0.35) (-0.63) (-0.32)		0.0001 (1.64) (0.82) (2.71) (1.36)	0.74
DK	2.4 (4.4) (2.41) (4.44) (1.71)	-0.009 (-1.88) (-0.58) (-1.88) (-0.72)	-0.004 (-0.15) (-0.04) (-0.15) (-0.05)	1.06 (2.41) (0.8) (2.41) (0.92)		0.011 (3.16) (1.11) (3.16) (1.22)	-0.004 (-1.64) (-0.45) (-1.64) (-0.63)	-0.04 (-1.29) (-0.43) (-1.29) (-0.5)		0.0001 (3.2) (0.84) (3.2) (1.2)	0.62

Table 2.1 Factor-Market Regressions Using 25 Factor-French Portfolios	
CAPM	
Tests for Joint Significance	
Volatility Model	SVW t and t 2c = 5.99
GARCH	76.3*
	14.6**
	14.1***
	2.7****
EGARCH	4.5
	3.3
	2.5
	1.9
TGARCH	61.5
	16.1
	61.5
	16.13
HRS	7.4
	2.9
	14.0
	5.5
DK	7.7
	2.7
	7.4
	2.6

Table 2: \*t statistics adjusted for cross-section heteroskedasticity; \*\*adjusted for Shanken standard error; \*\*\*newey-west adjusted standard error, \*\*\*\*newey-west and Shanken adjusted standard error

Table 2.2 Factor-Multivariate Regressions Using 25 Factor-French Portfolios

Factor-French Factors	
Tests for Joint Significance	
Volatility Model	DFM t and $\tau$ $\alpha = 5\%$
GARCH	2.60
	1.88
	3.54
	2.52
EGARCH	7.6
	4.9
	9.65
	6.22
TGARCH	0.93
	0.74
	0.95
	0.77
HRS	1.25
	0.95
	3.01
	2.2
DK	2.5
	1.69
	5.23
	3.43

Table 1.3 Firm  $\alpha$ -Machath Regressions Using 25 Firm  $\alpha$ -French Portfolios

Volatility Model	CAPM with $cay$ as Instrument		
	All $2\sigma = 9.48$	$cay$ as Instrument $2\sigma = 5.99$	$cay$ Factor $\rightarrow 1$
GARCH	83.86	72.34	$2\sigma = 1.68$
	13.92	12.08	5.99
	26.5	18.5	6.87
	4.46	3.11	1.15
EGARCH	13.64	7.08	8.01
	4.8	2.51	2.8
	20.01	10.5	7.34
	6.99	6.8	2.6
TGARCH	120.4	48.4	4.05
	23.32	9.96	0.85
	33.06	17.3	18.15
	6.9	3.6	3.77
HRS	46.3	16.9	1.4
	15.87	6.3	1.28
	15.01	6.47	5.43
	5.59	2.43	2.05
DK	9.58	6.55	6.4
	3.33	2.33	0.14
	8.7	8.7	1.78
	3.03	3.02	0.62

Table 2.4 Firm  $\sigma$ -M  $\sigma$  with Regressions Using 25 Firm  $\sigma$ -French Portfolios

Volatility Model	Tests for Joint Significance		
	CAFM with $\sigma_{it}$ and $\sigma_{it}$ as Instrument	All $t$ and $t$	$\sigma_{it}$ Factor $\sigma_{it}$
	$1\sigma = 9.45$	$1\sigma = 5.99$	$1\sigma = 0.99$ $1\sigma = 5.99$
GARCH	88.63	84.1	
	16.38	16.3	0.19
	24.6	18.43	3.8
	1.6	3.5	6.7
EGARCH	40.33	11.69	1.57
	6.7	2.17	0.28
	14.3	11.0	0.6
	2.63	2.03	0.11
TGARCH	23.6	24.8	3.9
	6.2	1.4	0.80
	25.8	17.4	1.6
	1.7	1.8	1.23
HRS	47.56	16.9	0.68
	16.88	4.1	0.26
	14.2	4.25	3.22
	1.3	1.62	1.19
DK	24.3	6.64	2.78
	5.03	1.4	0.58
	15.7	9.36	5.02
	1.3	1.96	1.05

Table 2.3 Fama 2-Market Regressions Using 23 Fama-French Portfolios

Ludvigson and Lettau's Scaled Models

Tests for Joint Significance

Volatility Model	All $\chi^2 = 9.58$	SUM t and t $\chi^2 = 5.99$	Key Factors $\chi^2$
GARCH	30.74	16.4	$\chi^2 = 0.45$ 0.15
	7.44	4.2	
	18.2	14.5	
	4.6	3.7	
EGARCH	96.8	58.3	23.6
	14.11	10.34	
	19.05	18.6	
	3.44	3.36	
TGARCH	79.0	73.3	3.88
	5.9	4.9	
	22.5	13.03	
	4.7	2.7	
HRS	33.2	8.1	0.1
	7.6	2.0	
	15.2	9.35	
	3.8	2.35	
DK	93.8	7.65	1.4
	1.46	0.38	
	6.2	4.15	
	0.91	0.61	



## The Cost of Financial Stability in Times of Crisis: the Case of Bulgaria

Vasil Stefanov Petkov  
University of National and World Economy, Sofia, Bulgaria  
[vasil1979@yahoo.com](mailto:vasil1979@yahoo.com)

### Abstract

*The global economic turmoil from 2008 inflicted permanent damage to EU economies and its impact is still strong. To address the problems and cope with the crisis governments were forced to conduct anti-cyclical policies in different forms. In most countries this resulted in a widening budget deficit and mounting government debt. Then, a raft of measures to deal with fiscal instability followed, which, however, restricted growth and had high economic and social costs. Bulgaria was among the EU Member States that turned fiscal discipline into a priority and was one of the few to manage, at least seemingly, to achieve satisfying results. The benefits that the country reaped are indisputable but the price it had to pay was too high. Many private sector companies faced insolvency, unemployment hit record highs, and important structural reforms were delayed.*

*This paper aims to clarify and weigh the advantages and disadvantages of austerity policy as precisely as possible. The conclusions can help in the evaluation of the possible implications of adopting specific measures in this direction.*

In the period between 2008 and 2009 the EU went through the worst economic crisis in its twenty-year history. The economies of most Member States collapsed and the links between the financial and the real sector were hampered by the chaotic economic environment. Private companies restricted their investment activity drastically and resorted to layoffs in order to avoid insolvency. This was the precise moment when more active government intervention was required to save the economy even if that meant abandoning some of the principles of neoliberal policy. Many governments in Europe reacted like that. This, combined with the high deficit and public debt levels that European countries have maintained since 2008, made part of Member States face the real threat of default. To avoid that outcome, governments resorted to **introduction of a number of public spending cuts which not only worsened the**

**economic stagnation but had a high social cost as well.** This austerity policy has been advocated by some of the leading European economies, mainly Germany, as well as by reputable international organizations like the IMF. Now, much like in the past, such measures have certainly proven to be controversial. The IMF can serve as a relevant example in this regard – it recently admitted that it had made mistakes and underestimated the seriousness of the situation in Greece [1]. A sign of optimism is the increasingly popular view that governments should shift towards adopting measures aimed at stimulating growth rather than austerity at any cost. This will most probably be the only possible way for the EU to keep its integrity and preserve its status as one of the leading economic centers in the world.

The global economic turmoil and the ensuing debt crisis in the EU have taken their toll on **Bulgaria**, as well, which is heavily dependent on the development of European economies. Nevertheless, the country has always strived to have a stable fiscal position and maintained its budget at a surplus before the recession. Yet, the external shocks that hit the Bulgarian economy in 2009 reflected in significant deterioration in the budget balance. It quickly turned from positive (at 1.7% of GDP in 2008) to negative (-4.3% of GDP) as a result of a strong contraction in budget revenues [4]. On the whole, the deficit was not at a dangerously high level but its widening by 6 percentage points in just one year (more than the expansion in Greece's budget gap – by 5.8 percentage points to reach -15.6% of GDP in 2009) was reason enough for the ensuing attempts to achieve fiscal consolidation. This policy was supported by low debt which was 14.6% of GDP in 2009. Thanks to the restrictive measures it adopted, the country successfully averted further widening of the budget gap and even managed to slash the deficit to -0.8% of GDP in 2012. This progress was driven mainly by improvements on the revenue side of the budget combined with a more modest increase in expenditure.

## Advantages of Fiscal Discipline

So far, the fiscal consolidation policy Bulgaria followed has undoubtedly had its benefits. The country has often been given as an example of **fiscal stability** as it has one of the lowest deficit and public debt levels in the EU and enjoys the high confidence of international institutions. As a result, in 2011 **the European Commission terminated the Excessive Deficit Procedure** against the country which started a year earlier. At the same time, *Moody's Investors Service* raised Bulgaria's credit rating from Baa3 to Baa2 with a stable outlook while other agencies confirmed their positive expectations for the development of the economy. **The good fiscal stance makes public finances and the overall economic conditions in the country more predictable.** On the upside, the narrowing of the deficit in 2011-2012 **has reduced risks that the government might be forced to resort to shocking tax hikes and more drastic slashing of certain public expenses** as was the case in a number of Member States. Thus, **Bulgaria has managed to keep its favorable tax rates** at 10% for corporate and personal income – among the lowest in the EU. The fiscal discipline maintained by the government was among the reasons behind the **steady downward trend in the yield on government securities** observed even against the backdrop of mounting uncertainty on European debt markets and the rising cost of financing faced by many Member States. With regard to the yield on ten-year government bonds, the country outperforms Romania, Poland, Hungary, and other Central and Eastern European nations and stands out in the region with its low external debt, small budget deficit, banking sector stability, and fiscal predictability.<sup>24</sup> At the same time, **the narrowing trend in the spreads between Bulgarian government securities and the benchmark German bonds** has become more pronounced. In addition, the values of the credit default swap (CDS) indicator have placed Bulgaria close to the Baltic States and the country has surpassed economies like Brazil, Russia, and Turkey where the risk of bankruptcy is estimated to be higher.

Although fiscal consolidation, which Bulgaria strives to achieve, is a step in the right direction, it should not be overemphasized and turned into an end in itself. Budget discipline provides a good basis for a more predictable and stable economic environment,

---

<sup>24</sup>In February 2013 the yield on Bulgarian government bonds with a maturity of ten years stood at 3.25% while in Romania, for instance, the cost of financing was much higher – 5.72%.

yet it is not sufficient for achieving high economic growth. A situation in which fiscal stability is accomplished at the expense of economic activity should be avoided. This applies to a certain extent to Bulgaria, as well. On the whole, the country has not managed to derive the maximum benefits from its small budget deficit and low public debt. In case the state is unable to actively support the economy, it should at least intervene by providing more incentives to businesses while at the same time seeking to repay its obligations to companies as soon as possible. This is an alternative which has been increasingly discussed.

## Disadvantages of Fiscal Discipline

The expectations that the payoff from the austerity policy consistently implemented by Bulgaria and from the pursuit of low government debt and a balanced budget will be bigger and will come sooner failed to materialize. In the end, the negatives actually prevailed and reality proved that tighter financial discipline has not brought Bulgaria the positive effects it desired. All economic agents have faced difficulties. The deteriorating financial condition of real sector enterprises has been a serious obstacle to economic development in the country. **Companies' revenues have stagnated, production activity has been weak, and corporate debt has mounted.** The government's support to businesses has been insufficient in the face of escalating uncertainty and restricted domestic and external demand. A shining example is the decline in public capital expenses after 2008 which in 2012 were about BGN 600 million (over EUR 305 million) below their pre-crisis levels [2]. Capital spending is the budget item which acts like a buffer when implementation of the revenue side fails since its size is most easily modified. Nevertheless, 2012 saw a slight acceleration in this element of the fiscal program, triggered by national co-financing of large-scale infrastructure and public works projects, funded under EU programs. This trend is expected to continue due to the need for more rapid absorption of European funds. In this regard, **additional efforts and better management are required in the utilization of EU funds.** Although Bulgaria has achieved progress in the negotiation of the funds, their absorption has been unsatisfactory. As of 31 March 2013 contracted funds under EU operational programs and agricultural funds stood at EUR 10.9 billion (95.6%) while the payments made until that moment were less than half that amount – EUR 4.5

billion (39.7%) [3]. When it comes to the level of absorption of EU funds, Bulgaria lags behind other Member States significantly and ranks among the worst performers. Many of the firms that are awarded contracts give up the projects because they encounter problems with finding sources for their share of the financing. As a result, the country is faced with the real threat of losing European money. Small and medium-sized enterprises (SMEs) are supported by the funds under the Joint European Resources for Micro to Medium Enterprises (JEREMIE) initiative. The instrument's aim is to improve their access to financing. In this regard, state intervention might be suggested in the form of providing municipalities with the funds they need to finance approved projects. Furthermore, ways to support private companies should also be sought since finding the funds required for project implementation is the last serious obstacle to absorption that businesses usually face. As a possible solution to this issue the government might consider establishing a special fund which will raise money by bond emissions and will thus transfer liquidity to the real sector.

Companies in Bulgaria face another significant problem – the delay in the repayment of public authorities' debts to business. In 2011 the state owed private firms around BGN 0.5 billion (about EUR 250 thousand), accumulated in the form of outstanding VAT refunds and unpaid procurement contract obligations. This situation has turned the government into one of the factors underlying intercompany indebtedness. In any case, the state should avoid delaying the repayment of its bills to companies with the purpose of keeping the budget at a balance. To address this problem, the government might consider **issuing bonds and using the raised funds to pay back its debts to private sector firms**. Thus, Bulgaria would be able to benefit from the low interest rates its government securities have registered over the past few years. The impact of issuing such bonds will be visible at a later stage – higher revenues from taxes and social security contributions which will reflect in an improvement in budget revenue and higher consumption, supported by a timely payment of salaries and a potential increase in their levels. A positive step in this direction was the payment of BGN 800 million (over EUR 400 million) to Bulgarian farmers at the beginning of 2013 since the money was raised precisely by a bond emission. There is no lack of demand for Bulgarian government securities with commercial banks showing particularly strong interest in them. The country's banking sector is

stable. Until now, the branches of foreign financial institutions have been using the significant resources accumulated from deposits to settle their obligations to parent banks abroad. However, they are now close to repaying them and, given restricted demand for lending, it is possible that the savings of residents will leak out of the country in the form of investments in foreign government securities. It should be noted that banks are willing to invest in Bulgarian bonds if the state decides to carry out such emissions.

Given the fact that the government provides no direct incentives to improve the situation of companies, it can at least take specific steps to relieve business activity. **The introduction of an electronic government** will provide substantial support to the private sector and will ease doing business in the country by saving time, reducing the administrative burden, and limiting corruption. The development of e-government in Bulgaria started back in 2002 when formulation of the first strategies began, working groups were set up, and plans for introduction were created. Nevertheless, progress has been insignificant so far and the initiative has been only partially implemented. In this regard, Bulgaria can follow the successful examples of other EU Member States which are the best performers in this area like Austria and especially Estonia.

The private sector has been forced to resort to staff reduction in order to avoid bankruptcy against the background of weaker financial results and the lack of good development prospects given fragile market demand in Bulgaria's leading European partners and constrained consumer spending at home. As a result, since 2009 the Bulgarian economy has been faced with another problem with significant social implications – constantly **mounting unemployment**. Economic woes have led to the destruction of more than 400,000 jobs and the state has adopted no substantial measures to address this issue [3]. The efforts to resolve this deepening problem have been backed by the absorption of funds under OP Human Resources which was merely 37.2% in March 2013. A step in a positive direction was the introduction of a new incentive to investors which involves reimbursing part of mandatory social security contributions paid by employers for a certain period of time. This measure should not be associated with any potential losses for the country as it will have many positive effects in the future, including attracting investors, boosting employment, and thus increasing budget revenues in the long term.

Last but not least, we have witnessed a process of **impoverishment of the population and income differentiation** in Bulgaria. Household expenses have been growing more rapidly than incomes which are spent primarily on basic necessities like utilities and food. The poorer layers of the population have faced increasing economic hardship and are in serious need of support. Against this background, any additional austerity measures to tighten the fiscal discipline would have a painful impact on the purchasing power of Bulgarian citizens. A step that would have significant positive social implications and might back efforts to resolve the impoverishment problem in the country would be to reintroduce the **non-taxable minimum income**. The upside would be an expected relief for the people with the lowest incomes in the country given that currently those receiving a minimum salary also pay the 10% flat tax. Other welfare measures planned by the government include raising maternity allowances (from BGN 240 to BGN 310), increasing the one-off aid for children enrolled in first grade (from BGN 150 to BGN 250), and expanding the access to energy benefits. These measures will not lead to a large deterioration in the budget balance and at the same time their effect will not only be immediate but also permanent. In turn, these incentives will reflect in higher consumption which, against the background of weak export growth, will provide a significant boost to economic activity in the country.

The crisis has certainly highlighted a number of unresolved problems in the Bulgarian economy which have obviously hampered its development. Instead of taking steps to gradually and consistently resolve the issues, however, in recent years governments have followed an inactive policy involving no attempts to make serious and long-term changes. It seems that the state's efforts have focused more on achieving fiscal stability by introducing a raft of restrictions rather than on generating more substantial economic growth. Yet, one should not happen at the expense of the other. A consistent policy which has to be followed unconditionally is necessary – a clear vision with specific priorities and measures targeted at improving economic conditions in Bulgaria. Whatever positive changes the government tries to make in order to revive the economy, it will not achieve the maximum and long-lasting results that **structural reforms** could bring. Reforms in the sphere of health, education, the pension system, and energy, among others, have been repetitively postponed. Without reform implementation, simply pouring money into the

economy would be pointless. Health and education should have a priority and the state should allocate the necessary time and resources to them. The cumbersome healthcare system is in need of a thorough change and a new strategy to guarantee higher quality and more affordable health services, to stop medical workers from leaving the country (mainly because of low pay), and to solve the problems with drug prices. Bulgaria takes the 24th place among EU Member States by healthcare budget expenditure – only 4.6% of GDP [4]. In comparison, Germany and the United Kingdom spend almost twice as much on health – 7% and 8% of GDP, respectively. These countries stand out with constantly rising employment and high remuneration levels in the sphere of human health and social work activities. These factors make them attractive destinations for Bulgarian medical workers.

The low quality of education at all levels has a negative impact on Bulgaria's economic potential. The lack of coordination between universities and businesses is an especially serious problem which results in a mismatch between labor supply and demand. A possible measure in this regard would be to link a part of every university's financing with the availability and the quality of its career development and entrepreneurship centers. When compared with the other EU Member States, Bulgaria lags significantly behind in terms of resources spent in this area and is at the bottom of the ranking. Education expenditure has been falling constantly since 2009 and in 2011 amounted to 3.6% of GDP [4]. Education and research and development are spheres where money and effort should not be spared as the benefits they bring are both long-term and long-lasting.

The public debt crisis that spread in some EU Member States, especially in the Eurozone, was the reason why financial stability has been placed at the center of hot debates involving not only economic analysts but also political figures. Given that the economic environment is not expected to improve considerably in the short term, public finance stabilization is set to require stronger political will and further policy action. Against the background of the European reality, Bulgaria stands out as the best performer in terms of budget deficit and government debt levels as a percentage of GDP – among the lowest in the EU. These results show that tightening the fiscal discipline is perhaps justified under such circumstances. Although this policy lays the foundation for substantial economic growth, it also gives rise to numerous controversies. In Bulgaria,

they are related to the deterioration in companies' profits, mounting unemployment, impoverishment of the population, and impediments to key public sector reforms, among others. In general, progress towards fiscal consolidation should be gradual and in line with the pace of economic recovery. The policies conducted by the government should result in short-term benefits to the economy while at the same time they should cover long-run development goals. This, however, is not an easy task and has proven to be a serious challenge for policy-makers in the country. In this regard, the government should focus its efforts not only on maintaining fiscal stability, but on improving the business environment and reducing the administrative burden as well. More precisely, Bulgaria should make full use of the possibilities for conducting fiscal policy, however limited they may be. Even some expansion in the budget deficit and public debt is acceptable if its aim is economic recovery.

## References

[1] IMF, Country Report No. 13/156, "*Greece: Ex Post Evaluation of Exceptional Access under the 2010 Stand-By Arrangement*", Washington, D.C., June 2013.

[2] The Ministry of Finance, Информационен бюлетин, Изпълнение на консолидирания бюджет [Information Bulletin: Consolidated Fiscal Program Implementation], December 2008, 2012.

[3] EU Structural Funds, Single Information Web Portal, <http://www.eufunds.bg/>

[4] Statistical Office of the European Union, Eurostat, <http://epp.eurostat.ec.europa.eu/>

# Risk Management as a Conduit of Effective Corporate Governance and Financial Performance of Small and Medium Scale Enterprises

Abraham Ansong

Department of Management Studies, University of Cape Coast  
[ansongabraham@yahoo.com](mailto:ansongabraham@yahoo.com)

## Abstract

*Previous attempts to measure the quality of corporate governance tend to focus on inputs of governance such as the separation of the CEO and the chairman's roles and the composition of boards, largely based on the agency theory. The purpose of this paper is to examine the extent to which risk management can be incorporated into the corporate governance framework on the backdrop of stewardship theory. After reviewing some of the key issues from literature, the paper demonstrates how relevant risk management practices are to the governance of the SME sector. It also made clear that both corporate governance and risk management have a positive relationship with financial performance. In the end, it advocates for the need for both practitioners and researchers to pay attention to issues of risk management when analyzing the extent to which corporate governance principles are being adhered to by business organizations.*

**Keywords:** Risk management, corporate governance, financial performance, SMEs

## 1. Introduction

The landmark study of [6] laid the foundation for further studies on the concepts of corporate governance and risk management. The thrust of their argument was that those who legally own business organisations have been separated from their control. Therefore, corporate governance and risk management must be established to ensure the presence of systems and institutions to direct the way companies are governed to limit the risk of business failure and the abuse of financial resources.

Later, [32] and [19] founded the agency theory. The notion of the theory is that in the presence of information asymmetries and self-seeking behaviour in the real world of business, individuals would use informational and other advantages to transfer wealth

to themselves from others. Early attention on such behaviour, however, focused on conflicts of interest between shareholders and managers [6] on one hand, and shareholders and bondholders on the other. Later, other stakeholders were brought into the scheme. Ways of solving these conflicts are the concerns of both corporate governance and risk management.

Nevertheless, within the context of Small and Medium Scale Enterprises (SMEs) the motivation to adapt these concepts may not necessarily be due to the 'agency problem' because of the underlying attribute of the rareness of the separation between ownership and management, especially in developing economies ([41]; [11]). Owner-managers of such enterprises are expected to be altruistic and so manage the affairs of the business to best of their abilities to meet both their expectations as well as those of other stakeholders. The stewardship and stakeholder theory therefore becomes the main theoretical bases for studies on corporate governance in SMEs. Stewardship theory argues that management do not behave opportunistically, but rather wants to do a good job and therefore rejects the lack of trust between shareholders and managers as advanced by agency theory. While the stakeholder theory addresses the need to balance the claims of shareholders with those of other stakeholders [33]. Empirically and theoretically, both corporate governance and risk management have an influence on financial performance of organisations irrespective of their size.

The issue of corporate governance has been a growing area of management research especially among large and listed firms [1]. The limited studies (For example, [2]; [25]; [4];[18]; [16]) that have been conducted this far within the SME sector have been based on agency theory and thereby relied largely on indices applicable to large and well-resourced firms. It is crucial to examine corporate governance in the SME sector from the context of a developing economy with the view of highlighting the relevance of risk management and other sector-specific indices as important measures of effective corporate governance.

[11] recommends the need for specific and simple SME governance arrangements that reflect their particular form and architecture. These forms include the predominance of family based firms with a strong crossover between managers and owners. According to the author, this provision should also recognize the largely fictional notion of separation in SMEs that is, in fact, more apposite for large and listed firms. Among other variables, [14] postulated risk management as an important measure of corporate governance in SME studies.

Therefore, this paper theoretically examines the relationship between good corporate governance and risk management, the need for the extension of corporate governance indicators to include risk management in SME studies and the impact both concepts will have on financial performance. The discussions are done with respect to the Ghanaian SME sector given the important role they play in the economy.

The Ghana Statistical Service (GSS) viewed firms with less than 10 employees as Small Scale Enterprises and their counterparts with more than 10 employees as Medium and Large-Sized Enterprises. In Ghana, this sector is viewed as a significant source of employment creation and national revenue through taxation ([20]; [22]; [3]). [3] posit that SMEs contribute about 75% to Ghana's GDP and also account for 85% of employment in the manufacturing sector. But more importantly within the context of development, a growth in this sector has a relationship with poverty alleviation ([26]; [15]).

## **2. Corporate governance and risk management**

Corporate governance and risk management are interrelated and interdependent. The sustainability of company's performance is highly depended on the effective role of both concepts. The element of control is one of the corporate governance roles, while a controlled environment is developed from the risk management process [23]. Thus, [23] defined corporate governance in relation to risk management as the medium by which an organization is governed and controlled in order to achieve its objectives. The controlled environment makes an organization reliable in achieving these objectives within an acceptable degree of risk.

Risk management is an effective technique for minimizing undesirable effects of risks and optimizing the benefits of risky situations [13]. [9] describes the aim of risk management as process enhancement that is established through systematic identification,

evaluation and mitigation of project risks. The function and objective of both corporate governance and risk management is to maximize shareholder value ([34]; [8]). They are connected to assist organizations to better understand risks, to improve and deliver its objectives and to mitigate, assess, and manage risk in an appropriate manner [27].

Recent accounts on company failures, corporate scandals, and frauds are among the reasons for companies to effectively implement risk management programmes. These companies' failures have been blamed on poor risk management and corporate governance. For example, in the East Asian financial crisis in 1997, weak corporate governance and poor risk management have been found as the main factors of companies' failure [28].

## **3. Risk Management and Financial Performance**

In a perfect capital market with no asymmetric information, risk management at the firm level should be a negative NPV project [31]. However, [36], [37], [30], [40] and [5] present arguments under which risk management activities could be value increasing for a firm and its stakeholders when agency costs, market imperfections and information asymmetries interfere with the operation of perfect capital markets. [36] and [37] argue that any potential value creation role for risk management is in the reduction or elimination of "costly lower-tail outcomes." Lower tail outcomes are primarily negative earnings and cash flow shocks and can have both direct and indirect costs. Direct costs are incurred in events such as bankruptcy and financial distress when the firm must make outlays to creditors, lawyers and courts. Indirect costs of associated with negative earnings and cash flow shocks, include the loss of reputation that may affect customer and vendor relationships.

In addition, indirect costs hamper the ability to pursue profitable growth options, and the ability to realize the full value of intangible assets upon liquidation. A decline in debt ratings and the resulting increase in borrowing costs can also be costly for shareholders in that previously positive NPV projects may now have to be foregone. Direct costs also include the costs associated with missing earnings targets and violating debt covenants.

[36] and [37] further argued that risk management can be value creating if it is able to reduce the likelihood of these negative earnings shocks and in turn, help the firm avoid the direct and indirect costs associated with financial distress. Similarly, [40] postulate that risk management can persuade

stockholders to invest in companies specific assets. These resources include processes of producing specific products or using certain technologies in industries that use knowledge for productions and services. In addition, such investments that are caused by employees, suppliers, customers and partners are a kind of financial resource that are often rare and valuable and are basis for higher economic value and gaining competitive advantage. [5] concluded that risk management reduces a firm's average capital expenditure and contract costs as it eases access to resources.

In a 2005 article, in which [39] assessed the effect of financial sector liberalization policies on the financial management of SMEs in Ghana, using six case studies, they found that the decision of investors to invest in SMEs depends on their perception of risk concerning these firms and other available alternative investment opportunities. These findings suggest that risk management enhance SMEs access to credit and consequently improve their financial performance.

#### **4. Corporate governance and Financial Performance**

Poor governance systems have been identified to have thwarted efforts of SMEs at attracting finance and thus are deemed to be one of the main barriers to their performance ([17]; [2]). [2] reasoned that the perception of higher risk, informational barriers, and the higher costs of intermediation for smaller firms explains the reluctance of financial institutions to advance credit to SMEs.

[12] reported that good governance improves SMEs' prospect of obtaining funds from banks, investors and venture capitalists. They also contend that firms that have greater transparency or information disclosure tend to have healthier growth rates and ratios of ordinary profits to that of capital, than firms who do not do so. Hence, corporate governance has a role in SME performance since it improves transparency and attracts capital at a cheaper cost [35].

According to [35], corporate governance has significant implications for the growth and development prospects for even the overall economy, because proper corporate governance practices reduce risk for investors, attract investment capital and improve performance of companies.

[10] identified several channels through which corporate governance influences growth and development. The first is the increased access to external financing by firms. This in turn can lead to larger investment, higher growth, and greater

employment creation. The second channel is a lowering of the cost of capital and associated higher firm valuation. This makes more investments attractive to investors, also leading to growth and more employment. The third channel is better operational performance through better allocation of resources and better management. This creates wealth more generally. Fourth, good corporate governance can be associated with a reduced risk of financial crises. This is particularly important, as financial crises can have large economic and social costs. Fifth, good corporate governance can mean generally better relationships with all stakeholders. This helps improve social and labour relationships and aspects such as environmental protection.

Considerable evidence further exists to establish the link between access to credit and improved performance of SMEs ([21]; [7]; [38]; [12]; [29]). For example, [7] found a higher valuation, higher profitability and higher dividends payments for better-governed firms. Therefore, corporate governance is hypothesized to have a relationship with the financial performance of SMEs.

Some empirical studies in Ghana have established a relationship between measures of corporate governance and financial performance. For instance, [2] sought to assess how the adoption of corporate governance structures affects the performance of SMEs (small to medium-sized enterprises) in Ghana. Regression analysis was used to estimate the relationship between corporate governance and ownership structure and performance. The study showed that board size, board composition, management skill level, CEO duality, inside ownership, family business, and foreign ownership have significantly positive impacts on profitability.

A year later, [25] set out to examine corporate governance practices of SMEs in Ghana and whether there is any linkage between these governance practices of SMEs and financial performance. They employed two levels of interaction to achieve these objectives: The first was an interview for a general understanding of governance issues in the SME sector and the subsequent design of a questionnaire for an exploration of the linkages between governance issues and firm financial performance by employing a linear model.

The study revealed that governance structures in SMEs were jointly influenced by credit providers and business ethical considerations. The regression results showed that board size, size of audit committees, corporate ethics and the proportion of outsiders on the audit committees have negative impact on financial



performance while independence of the board and the presence of audit committees enhance firms' financial performance.

## 5. Conclusion

The significance of corporate governance cannot be over emphasized as it creates the necessary organizational setting for the internal operations of a business enterprise. The implementation of corporate governance canons among SMEs can result in better management practices, stronger internal auditing and greater opportunities for growth. The issue, however, is that the known indices of corporate governance employed in larger firms such as board composition, CEO tenure and duality and so on are not applicable to SMEs, especially in developing economies. This paper established the link between risk management and corporate governance as well as the relationship between risk management and financial performance in order to advocate for the inclusion of risk management as a measure of an effective corporate governance practices by both practitioners and academic researchers. A consistent track record of effective risk management just like corporate governance will greatly assist SMEs when it becomes necessary to solicit for external funding. This paper also argues that risk management have a positive effect on the financial performance of business organisations and must therefore be pursued. It must be noted that both good governance and risk management do not automatically guarantee business success. However, their absence could be indicative of a business failure.

## 6. References

1. J. Abor, and C. Adjasi, "Corporate governance and the small and medium enterprises sector: theory and implications", *Corporate Governance: International Journal of Business in Society*, 2007, 7(2), 111-22.
2. J. Abor, and N. Biekpe, "Corporate governance, ownership structure and performance of SMEs in Ghana: implication for financing opportunities", *Corporate Governance*, 2007, 7(3), 228-300.
3. J. Abor, and P. Quartey. "Issues in SME development in Ghana and South Africa." *International Research Journal of Finance and Economics*, 2010, 39(1), 218-228.
4. B. Al-Najjar, *The impact of board size and independence on SMEs financial decisions: Evidence from UK*. Working Paper, Middlesex University, UK, 2009.
5. T.J. Andersen, "The performance relationship of effective risk management: Exploring the firm-specific investment rationale." *Long range planning*, 2008, 41(2), 155-176.
6. A., Berle, and G.C. Means, *The modern corporation and private property*, New York, Macmillan Co., 1932.
7. I.D. Brown, and M.I. Caylor, "Corporate governance and firm valuation." *Journal of Accounting and Public Policy*, 2006, 25, 409-434.
8. C. Busco, M.L. Frigo, E. Giovannoni, A. Riccaboni, and R.W. Scapens. "Beyond compliance: Why integrated governance matters today." *Strategic Finance*, 2005, 87(2), 35-43.
9. C. Chapman, and S. Ward, "Project risk management-processes, techniques and insights" in Jafari, M., Chadegani, A., A. & Biglari, V. (2011). "Effective risk management and company's performance: Investment in innovations and intellectual capital using behavioural and practical approach", *Journal of Economics and International Finance*, 1997, 3(15), 780-786.
10. S. Claessens, Corporate governance and development: Review of the literatures and outstanding research issues. *Proceedings of the Global Corporate Governance Forum Donors Meeting*, March 13, 2003, The Hague, The Netherlands.
11. A.D. Clarke, SMEs and corporate governance: Politics, resources and tinkle-down effects presented in Corporate Law Conference, University of Queensland, 5-7 February, 2006.
12. I. Dube, D. Dube, D. and P. Mishra, "Corporate governance norm for SMEs". *Journal of Public Administration and Governance*, 2011, 1(2), 2161-7104.
13. J. Essinger, and J. Rosen, "Using technology for risk management in Jafari, M., Chadegani, A., A. & Biglari, V. (2011). Effective risk management and company's performance: Investment in innovations and intellectual capital using behavioural and practical approach", *Journal of Economics and International Finance*, 1991, 3(15), 780-786.

14. A.K. Garg, and E.V. Weele, Succession planning and its impact on the performance of small, micro, and medium enterprises within the manufacturing sector in Johannesburg. *International Journal of Business and Management*, 2012, 7(9), 96-107.
15. G.H. Gebremariam, T.G. Gebremedhin, and R.W. Jackson, The role of small business in economic growth and poverty alleviation in West Virginia: An empirical analysis. *Selected Paper presented at the American Agricultural Economics Association Annual Meeting, Denver, Colorado, August 1-4, 2004*.
16. A.S. Gill, H.S. Mand, and N. Mathur, "Corporate governance and the growth of small business service firms in India." *International Research Journal of Finance and Economics*, 2012, 1(96), 113-123.
17. A.G. Gockel, and S.K. Akoena, Financial intermediation for the poor: credit demand by micro, small and medium scale enterprises in Ghana. A further assignment for financial sector policy? IFLIP Research Paper 02-6, International Labour Organization, Geneva, 2002.
18. S.B. Hamad, and A. Karoui "The SMEs governance mechanisms practices and financial performance: Case of Tunisian industrial SMEs." *International Journal of Business and Management*, 2011, 6(7), 216-225.
19. M. Jensen, and W. Meckling (1976), "Theory of the firm: Managerial behaviour, agency costs and ownership structure." *Journal of Financial Economics*, 1976, 5, 305-360.
20. D. Kayanula and P. Quartey, The policy environment for promoting small and medium-sized enterprises in Ghana and Malawi, Paper No. 15, Finance and Development Research Programme Working Paper Series, IDPM, University of Manchester, 2000.
21. L. Kasekende, and H. Opondo, Financing small and medium scale enterprises (SMEs): Uganda's experience, *Bank of Uganda Working Paper*, WP/03/01, 2003.
22. H. Keskin, Market orientation, learning orientation, and innovation capabilities in SMEs: An extended model. *European Journal of Innovation Management*, 2006, 9(4), 396-417.
23. K.W. Knight, Risk management a journey not a destination. Paper presented at the Executive Meeting 2006. Hotel Do Frade & Golf Resort, Angra Dos Reis, Brazil. 20th May 2006.
24. A. Kyereboah-Coleman, Relationship between corporate governance and firm performance: An African perspective. Ph.D Thesis, University of Stellenbosch, South Africa, 2007.
25. A. Kyereboah-Coleman, A. and M. Amidu, "Examine the link between small business governance and performance: A case of small and medium scale enterprises in Ghana." *Journal of African Business*, 2008, 9(1), 121-143.
26. D.S. Landes, *The wealth and poverty of nations*, New York: W.W. Norton, 1998.
27. N.A. Manab, I. Kassim, and M.R. Hussin. "Enterprise-wide risk management practices: between corporate governance compliance and value creation." *International Review of Business Research Papers*, 2010, 6(2), 239-252.
28. T. Mitton, "A cross-firm analysis of the impact of corporate governance on the East Asian financial crisis." *Journal of Financial Economic*.2002, 64, 215-241.
29. J. Nakiyingi, Managerial competence, access to credit and business success. Master Thesis, Makerere University, 2012.
30. B.W. Nocco, and R. Stulz, "Enterprise risk management: Theory and practice," *Journal of Applied Corporate Finance*, 2006, 18(4), 8-20.
31. D. Pagach, and R. Warr, An empirical investigation of the characteristics of firms adopting enterprise risk management, *North Carolina State University working paper*, 2010.
32. S.A. Ross, "The economic theory of agency: The principals' problems." *American Economic Review*, 1973, 63, 134-139.
33. B. Ruf, K. Muralidhar, and K. Paul, The development of a systematic, aggregate measure of corporate social performance. *Journal of Management*, 1998, 24(1), 119-33.

34. P.J. Sobel, and K.F. Reding (2004). "Aligning corporate governance with enterprise risk management." *Management Accounting Quarterly*, 2004, 5(2), 29-37.
35. L.J. Spanos, "Corporate governance in Greece: Developments and policy implications," *Corporate governance*, 2005, 5(1), 15-30.
36. R. Stulz, "Rethinking risk management", *Journal of Applied Corporate Finance*, 1996, 9(3), 8-24.
37. R. Stulz, *Rethinking risk management: The revolution in corporate finance*, 4th Edition, Blackwell Publishing, 367-384, 2003.
38. J. Su and Y. Sun, "Informal finance, trade credit and private firm performance." *Nakai Business Review International*, 2011, 2(4), 383-400.
39. N. Tagoe, E., Nyarko, and E. Anuwa-Amarh, "Financial challenges facing urban SMEs under financial sector liberalization in Ghana". *Journal of Small Business Management*, 2005, 43(3), 331-343.
40. H. Wang, and J.J. Reuer, Risk reduction through acquisitions: The roles of firm-specific investments and agency hazards. *Advances in Mergers & Acquisitions*, 2006, 5, 25-49.
41. E., Yacuzzi, A primer on governance and performance in small and medium-sized enterprises. CEMA Working Papers Serie Documentos de Trabajo. 293, Universidad del CEMA, 2005.

# Internalization of Externalities of Influence of Youngest Plywood Industry in Java Profits

Sugiartiningsih  
Widyatama University - Bandung - Indonesia  
[sugiarti.ningsih@widyatama.ac.i](mailto:sugiarti.ningsih@widyatama.ac.i)

## Abstract

*This study aimed to determine the effect of internalizing the externality on profits plywood industry in Indonesia.*

*This study uses the economic approach to international trade is mixed with natural resource economics that focuses on the internalization of externalities. More specifically approached from the aspects of international trade, namely the effect on profits internalize externalities plywood industry in Indonesia. Data were collected for the youngest plywood industry in Java that are still active plywood exports to the United States. The method of analysis is done by dynamic analysis using the techniques of the calculus of variations.*

*The results showed the influence of internalizing externalities would increase profits up to a point. Then in the long run the plywood industry profits increase, because the response of the U.S. consumer.*

*Keywords: internalization of externalities, profit*

## Introduction

### Background Research

Since the New Order Indonesia's economy is highly dependent on international trade. Where the commodity exports of natural resources become the foundation of foreign exchange earnings. One of the prime export product is plywood products. By reason Indonesia is a tropical country have the high potential for the growth of natural forests into raw material for making plywood.

Impact on the volume of Indonesia's plywood exports to International markets are very high, especially to Japan, United States and South Korea. However, the export success to be followed by tropical deforestation on a large scale. In addition to forest damage it can cause exfoliation of the ozone layer and global warming. The situation we are all aware that the forests are the lungs of the earth. For it must be environmentally sustainable trade.

As the realization of the statement written WTO rules stipulate that each country should trade in environmental conservation (March Priyanta, Nadia A. Amiruddin Dajaan Astriani and Imami, 2012)). The appeal was a big challenge for Indonesia especially for the plywood industry to remain competitive in the international market. Especially when considering the volume of Indonesia's plywood exports to the United States has been a decline. As we all know the United States is one country that is responding preservation of forests in Indonesia. In fact the volume of Indonesia's plywood exports to the United States had the largest decline in 1994 of 41.5%.

Consequently plywood industry in Indonesia must pay more attention to IHPA standards include the use of raw materials from forests owned by legal logging. Apart from the requirement of raw materials further plywood industry should pay attention to the process of production by internalizing externalities into the cost of production. The company's ability to respond to these conditions is expected to encourage efficiency properties, which in turn will increase the company's profits in both the short and long term.

Based on the phenomena above, it is interesting to examine the effect of internalizing the externality on profits plywood industry's in Indonesia. Where the focus of research on the youngest plywood industry in Java which has great potential to export plywood to the USA.

### Identify the Problem

Based on the description on the background of the problem posed identification problem is how to internalize the externality effect on net exports of plywood industry in Java to United States?

### Research purposes

The purpose of this study was to determine the effect of internalizing externalities on export profits plywood industry in Java to the United States.

## Conceptual Framework and Hypothesis

International trade always aim to make a profit (Nopirin; 1995). For exporters gain can occur when international market prices higher than in the country. Instead importers feel disadvantaged when the international market price is lower than the domestic price.

Talking about international trade theory we know that there are two very well known that the classical theory of trade and modern trade theory. In the classical theory states that countries want to trade because it has an absolute and comparative advantage. In accordance with the findings of Adam Smith stated that bilateral trade can occur when the two countries in the use of labor has an absolute advantage in any of the products traded. Meanwhile, according to David Ricardo's argument through price comparisons by the two countries instead of a country will have a comparative advantage. The modern theory emphasizes that international trade is highly dependent on the factor endowment held that a country tends to produce products that are labor-intensive or capital-intensive.

The second approach is based on the theory above, it is logical for a country to rely on trade with abundant resources. For example, developed countries are more focused on capital-intensive industrial products instead of developing countries in labor-intensive industries. In further trade advantages depending on the ability of industrialists to be able to maintain its market share with two micro alternative that's lower production costs or increase its total revenue.

Especially for emphasis keen industrialist production costs must be able to respond to emerging environmental issues such as global warming, which will encourage action internalize externalities. Accordingly industrialists from the supply side should be able to act as high efficiency. While the demand side tie can be done by diversifying products through appropriate marketing strategies. With the possible forms of market monopoly producers expected to gain maximum profit.

From the little picture above the challenges of an industry to internalize the externalities it will increase its competitiveness in the international market that will likely boost profits in the short term and long term.

### Trade theory

International economy as part of the economics more emphasis on inter-State relations like trade,

investment, loans, aid and international cooperation (Nopirin, International Economics, 1995). Specifically to international trade only involves the exchange of goods and services, and the perpetrators include private, government and international organizations.

In development international trade done by all countries as it is influenced by several factors such as the limited availability of resources and products, financing and efficiency as well as preferences (Asfia Murni, 2009). Thus the purpose of international trade is to acquire goods that can not be produced domestically, increase national income and acquire modern technology.

The importance of international trade activities supported by classical and modern theory. Theories that include, among others, the classical theory of absolute advantage theory by Adam Smith, the theory of comparative advantage by David Ricardo, and the modern theory by Heckser and Ohlin. Each one of these theories break down as follows:

#### 1. Theory of Absolute Advantages

A State would conduct trade with other countries when in each country there is an absolute advantage in producing goods. To determine whether a country has an absolute advantage can be observed through the theory of absolute advantage.

The theory of absolute advantage by Adam Smith can be explained by the assumption that trade between the two countries occurred only with two kinds of product.

The following table shows an example of the number of workers needed to produce per unit.

	Japan	Korea
Car	20	30
Motor Cycle	25	15

The data table that Japan has an absolute advantage in producing cars since  $20 < 30$  workers, while Korea has the absolute advantage in producing motorcycles since  $15 < 25$  workers. So Japan will do to the car and Korean specialties will specialize on motorcycle products. After doing international trade Japan will export cars if the price in the international market over the  $1 \text{ car} = 0.8 \text{ motors}$  and Korea will import the car if the price in the international market under  $1 \text{ car} = 2 \text{ motors}$ . Therefore, the two countries will be benefited from international trade.

#### 2. Theory of Comparative Advantages

A State will swap / trade with countries in the following form:

a) Export, if any product produced has the comparative advantage. It means that products (goods) can be produced at a cheaper cost.

b) Imports, if any resulting product has a comparative disadvantage. It means that when the resulting product itself requires a higher cost compared to other countries.

Theory of Comparative Advantages can be explained by the table total production of 10 workers in the following week.

Type of goods	Japan	Indonesi a
Electronic items	6 unit	2 units
Wooden handicrafts	9 unit	6 unit

The data table shows Japan has a comparative advantage in producing electronics for  $3 : 1 > 1.5 : 1$ , while Indonesia has a comparative advantage in producing wooden crafts for  $2/3 : 1 > 1/3 : 1$ .

After conducting international trade will export Japanese electronics when international market prices above  $1 = 1.5$  woodcraft electronics and electronics when Indonesia will import prices in the international market under one electronic = 3 woodcraft. Therefore, the two countries will be benefited from international trade.

### 3. Factor Proportion Theory

This theory was put forward by Eli Heckscher and Bertil Ohlin. They assume that the difference in the number of factors of production owned by each State will make a difference in opportunity cost to produce a product.

There are countries that have a larger workforce than capital goods (machinery). So the price of labor can be said to be cheaper than the price of goods machine. This condition is directing the production activities in the country will be labor intensive. Contrary to the State which has a number of labor less than capital goods, the price of labor will be more expensive. Better production is capital intensive.

### Environmental Issues In Economic Activity

Global environmental problems faced by the attention and the world today is global warming (global warming) and resulted in an ever increasing climate change causing environmental degradation (preamble Considering Law No. 32 Year 2009 on the Protection and Management of the Environment) . Global warming will increase the earth's temperature resulting in widespread melting of the north polar ice,

rising sea temperatures, and resulting in rising sea levels, droughts will become dry and the rainy season will be wetter and increased rainfall and flooding conditions. This will affect human health as well as life-threatening (compare with Sharad Adhikary (WHO Representative to Indonesia), 2008: 24). Otto Soemarwoto with this stated that global warming is the earth's surface temperature increases event. As the temperature increases the energy contained in the atmosphere. The increase in the energy content led to climate change, among others, increase the frequency and intensity of storms and other extreme events. Global warming resulting in climate changes drive the growth and increasing of organisms, including disease-carrying organisms. For urban areas, the temperature rise by transportation activities, the use of air conditioning (AC) and shrinkage of green land (Otto Soemarwoto, 2004: 63-64)

Fourth Assessment Report issued by the Intergovernmental Panel on Climate Change (IOCC) states that: "... human activity during the last 250 years is what makes our planet is getting hotter. Increased concentration of CO<sub>2</sub> in Earth's atmosphere was the highest since 650,000 last year. The IPCC also concluded that 90% of greenhouse gases produced by humans, such as carbon dioxide, methane, and nitrous oxide, in particular during the last 50 years, has drastically raise the temperature of the earth ... " (Major Cause of Climate Change, <http://www.perubahaniklim.net/penyebab-utama-perubahan-iklim.htm>)

Population growth, deforestation, livestock industry, and the use of fossil fuels causes greenhouse gas increases in the atmosphere and provide a lot of impact on climate change.

Global warming is causing climate change and complex modern problems. Poverty, economic development and population growth is the cause. Not an easy thing to handle, and if we do not care about it will make matters worse. "... *Global warming is a 'modern' problem - complicated, involving the entire world, tangled up with difficult issues such as poverty, economic development and population growth. Dealing with it will not easy. Ignoring it will be worse* "(United Nations Framework Convention on Climate Change, Felt the Heat, in [http://unfccc.int/essential\\_background/feeling\\_the\\_heat/](http://unfccc.int/essential_background/feeling_the_heat/) date Feb. 1, 2010)

Efforts are made to overcome this problem, one of them through international cooperation that followed most of the countries in the world such as the United Nations Framework Convention on Climate Change, where it was agreed that the international community should start thinking about what to do to reduce the

cause of the warming resulting in global climate change.

Indonesia is an archipelago country. This resulted in the country of Indonesia is one of the countries affected by possible negative impacts of climate change (Susilo Bambang Yudoyono (President), 2007: iii). Indonesia has the Validation Framework of the United Nations About Climate Change (Kyoto Protocol to the United Nations Framework Convention On Climate Change) by Law number 17 of 2004. In essence, Indonesia adopted the protocol as outlined in national law for regulatory and institutional framework (Explanation of Act No. 17 Year 2004 on Ratification of the Framework Top United Nations on Climate Change (*Kyoto Protocol To The United Nations Framework Convention On Climate change*)).

With the passage of the climate change convention in national law and positive law then become environmental interests into consideration in any major decision-making and internalized in various development sectors, such as in the energy sector, forest management, natural resources, agriculture, plantation, spatial, and infrastructure. Under the 1997 Kyoto Protocol states that Indonesia is not classified in Annex 1 which has an obligation to reduce greenhouse gas emissions, but as a country exposed to possible negative impacts of climate change, Indonesia is interested in tackling and preventing climate change. One form of the Indonesian government's commitment provided by the President of the Republic of Indonesia in the Conference of the Parties (COP) 15 in 2009 which was held in Copenhagen Denmark, as a form of support for the Copenhagen Accord, the National Council on Climate Change (NCCC) sent a letter to the UNFCCC Secretariat expressed support for the Accord and Indonesia's commitment to reduce greenhouse gas emissions 26 percent by 2020 and 41 percent with international assistance through a letter dated January 19, 2010. This letter was followed by a formal proposal Indonesia targets to be attached to the Copenhagen Accord on January 27, 2010, with Deriving sectors to be included in the emission reduction initiatives (Agus Sari, date February 24, 2010).

According to official reports Second National Communication, the largest emissions in Indonesia in 2000, the sector generated by land-use change and forestry emissions total more than 1 gigatons (GT, billion tons of carbon dioxide equivalent), with 0.41 GT reabsorption, resulting in net emissions of 0.65 GT. Energy sector number two with 0.25 GT. Peat fires accounted for 0.17 GT.

In the period 2000 - 2006, the energy sector has the fastest growth by 5.7 percent per year, followed by the

industrial sector with 2.6 percent. Emissions from land use change, forest and peat fires (Land-Use Change, Forestry, LUCF and Peat Fire) fluctuate. Further stated that more than 80 percent emission reduction potential is there in the forestry sector and peat lands. Sectors that play a role in reducing emissions is generally a matter for local authorities such as air pollution control, atmospheric protection, forestry and transportation. Within the scope of local government, environmental control must become a business that must be implemented by local governments.

### ***Externalities Due Process of Plywood Production in Indonesia***

Plywood manufacturing process will be found vulnerable environment, ie pollutants (waste) which can be grouped into three, namely solids, liquids, and air. The liquid waste will occur, especially in the hydraulic timber barking and early treatment of pre-cut logs. While other waste resources on activities are adhesive and cleaning tool dryer. Besides water and air compressor cooling water kettle are also a significant waste of resources.

The water contains a lot of barking suspended solids and resin acids. Water purifier maker latex containing wood, producing phenol and resin acids. Second-hand washing machine water containing adhesive glue urea, phenol or amine. While the cooling water will be free of contaminants when the maintenance of cleanliness in the plant performed well.

Based on the Ministry of Environment (1995) shows that the main parameters of effluent to the plywood industry is BOD, TSS, phenols and resin. To that end, each of the plywood industry is required to recycle the waste water from the perfect plywood operations, based on the best practical technology that is 0.3 m<sup>3</sup>/m<sup>3</sup> of plywood products. This means the liquid wastes may be issued a maximum of 0.3 m<sup>3</sup>/m<sup>3</sup> of plywood products produced.

Solid waste in the form of dander, dust and leftover pieces of wood should be used in a way that does not cause pollution. Importantly, not to solid waste and dust accumulate in the plant, both inside and outside the building, because it was going to be carried away by rain water into ditches and streams.

For air waste can be divided into two, namely physical chemical waste and sewage. Chemical wastes, include nitrogen oxides, carbon monoxide, hydrocarbons, particulates and soot. Chemical waste is generated by a forklift while plywood stacking in warehouse ready to be exported. While the physical waste is usually intangible noise and temperature.

Where the noise comes from playing rotary veneer to be made under the set threshold of 70 dB (BAPEDAL, 1999). Extremely high temperatures will be found in two respects. First, when drying veneer after screening process will require heating to high temperatures. Second, in the hot press gluing veneer (Personal Communication, November 29 - December 4, 2004, Caisus and Dolog, Deperindag, Jakarta). Despite the high temperatures, but do not harm the species in the waters, as evidenced by the test cooks fish are most vulnerable to survive wastewater (Personal Communication, October 2002, Dolog, Deperindag, Jakarta).

### Hypothesis

The descriptions on the background of the problem, identification of the problem, research purpose and frame of mind on the hypothesis put forward is the internalization of positive externalities will affect the profits of export plywood industry on Java to the American States.

### Objects and Methods

#### Object Research

Research conducted on the youngest plywood industry in Java which has responded to the preservation of tropical forests in Indonesia and is still actively exporting plywood products to the United States. Thus, the research object is studied by internalizing externalities youngest plywood industry in Java and profits plywood exports to the United States.

#### Research Methods

The method used is descriptive continuous (continuity descriptive research), the investigation continued over an object of research, with attention to detail that dynamic changes in an interval (interval) time.

#### Types and Data Collection Period

The data used in this study are monthly time series data are restricted from 1995.01 to 2002.12 (84 months). 1995.01 due to limits on the initial response by internalizing externalities youngest plywood industry in Java. 2002.12 while because after that year plywood industry in Indonesia is experiencing an uncertain business conditions.

### Data Collection Procedures

For primary data such as waste handling costs and the cost of welfare of the people around the plant derived from the plywood industry. Similarly, for the secondary data such as plywood output level, the level of export prices and export volume of plywood industry to the United States obtained from the youngest plywood industry in Java. While supporting data such as exchange rates, the welfare cost around forests and abatement cost obtained from BPS and the internet.

### Basic Model Formulation

In accordance with the purpose of research is to analyze the influence of internalizing externalities on Indonesia's plywood exports to the United States, the internalization of externalities by plywood industry youngest in Java is the additional environmental costs should be internalized into the company's production costs. In modeling internalize externalities operationalized as the intensity of the environment is maintained continuously expressed in time ( $t$ ). In this study only want to know the effect on the level of internalization of externalities plywood industry profits youngest in Java.

By showing variable  $t$  then internalize externalities by profit function youngest plywood industry in Java interval  $t$  during the period was:

$$\pi(p, p', t) = Z(t) \cdot p(t) - C(Z)$$

wherein:

$\pi(p, p', t)$  = Function of profit is a function of  $p$  and  $p'$

$Z(t)$  = variable monthly export demand products labeled plywood youngest industry plywood on the in Java by the United States

$p = p(t)$  = Monthly export price variable labeled products plywood youngest industry plywood in Java to the United States

$$p' = p'(t) = \frac{dp(t)}{dt} = \text{Variable monthly rate of}$$

change in the export price of plywood products labeled youngest plywood industry in Java to the United States

$C(Z)$  = monthly variable production costs that have internalized environmental factors.

The equation shows the profit ( $\pi$ ) to be achieved by the company in connection with the implementation of internalizing externalities will increase.

### Specifications Model



Specification of the model in this study using the Euler-Lagrange development of the calculus of variations (calculus of variations) to the condition of point / end time permanent (fixed endpoint problem) and right-hand-free boundary conditions (right-hand free boundary problem). Equations required are:

Form demand function :

$$Z(t) = \ell(t) + m \frac{dp(t)}{dt} + n$$

Form of monthly production cost function :

$$C(Z) = aZ^2 + bZ + c$$

Form of profit function:

$$\begin{aligned} \pi(p, p', t) &= Z(t).p(t) - C(Z) \\ &= (\ell - a \ell^2)p^2 + (n - 2a \ell n - b \ell)p - \\ &\quad am^2(p')^2 - (2amn + mb)p' + \\ &\quad (m - 2a \ell m)p p' - (an^2 + bn + c) \end{aligned}$$

Of the profit function equation, then the maximum total profits youngest plywood industry in Java can be determined by using the calculus of variations approach (*calculus of variations*), namely:

$$\begin{aligned} \text{MaxI } (p) &= \int_0^{t_1} \pi(p, p') dt = \\ &\int_0^{t_1} \left\{ (\ell - a \ell^2)p^2 + (n - 2a \ell n - b \ell)p - am^2(p')^2 - (2amn + mb)p' \right. \\ &\quad \left. + (m - 2a \ell m)p p' - (an^2 + bn + c) \right\} dt \end{aligned}$$

where

$$\begin{aligned} t_0 = 0 & \quad p(t_0) = \text{specific} \\ t_1 = \text{determined} & \quad p(t_1) = \text{a) determined} \\ & \quad \text{b) not specified} \end{aligned}$$

to condition a):

$$\begin{aligned} t_0 = 0 & \quad p(t_0) = \text{specific} \\ t_1 = \text{determined} & \quad p(t_1) = \text{set, called fixed} \\ & \quad \text{endpoint problem} \end{aligned}$$

required:

Necessary condition: *the Euler-Lagrange equation*

$$\frac{\delta \pi}{\delta p} - \frac{d}{dt} \left( \frac{\delta \pi}{\delta p'} \right) = 0 \quad t_0 \leq t \leq t_1$$

be obtained by non-linear differential equations homogeneous form of two degree:

$$qp'' + zp' = -s$$

In order to obtain the general solution of the price trend  $p(t)$  in the form

$$p(t) = k_1 e^{rt} + k_2 e^{-rt} + g$$

For further results from the equation  $p(t)$  is substituted into the equation total maximum benefit by using integral limits specified, so that the maximum amount of profit the company can be known.

Condition b):

$$\begin{aligned} t_0 = 0 & \quad p(t_0) = \text{specific} \\ t_1 = \text{determined} & \quad p(t_1) = \text{not determined} \\ & \quad \text{called right-hand} \\ & \quad \text{free boundary problem} \end{aligned}$$

For this condition is necessary:

Necessary condition: *the Euler-Lagrange equation*

$$\frac{\delta \pi}{\delta p} - \frac{d}{dt} \left( \frac{\delta \pi}{\delta p'} \right) = 0$$

$$\text{Additional conditions: } \pi_{p'} \Big|_{t=t_1} = 0$$

Will obtain a homogeneous linear differential equation level 1 (one) in the form;

$$-u p' + vp - w = 0$$

In order to obtain the general solution of the price trend  $p(t)$  of the form:

$$p(t) = l_1 e^{rt} + l_2 e^{-rt} + h$$

of this equation the value of  $p(t_1)$  can be known and to further price trend equation  $p(t)$  is substituted into the equation so that the total maximum advantage of the maximum profit that the company wants to achieve can be determined.

## The Design of Hypothesis Testing

To test the hypothesis significance econometric model used in the dynamic modeling export demand equation ( $Zt$ ) and production costs ( $Ct$ ) in addition to the t-test and F-test also uses the classical assumption of multicollinearity, heteroscedasticity test and autocorrelation test. As for the hypothesis test equation with a dynamic model regressing towards  $\pi(t)$ .

## Results

### Prices Function Model and Price Changes on the Demand

Based on the results of research on the plywood industry youngest in Java over the period 1995.01-2002.12 then obtained the following results:

$$Z = -5,684 P + 95,026 DP + 6,077,001$$

$$(-2,378) \quad (44,077) \quad (3,826)$$

$$R^2 = 0,969 \quad F = 1267,454$$

The above calculation results are in accordance with theoretical where P and Z are negatively related while Z is positively related to the DP. Judging from the results of tests of significance were also seen successful of t-test, F-test and  $R^2$  as well as classical

assumptions. More results shown in the following table:

Multicollinearity test	0,524	t = 5.537	t-tab = 1.990	Multicollinearity occurred, but still good
Heteroskedasticity test (rS)	0.439 & 0.207	t = 4.397 & 1.904	t-tab = 1.990	Heteroscedasticity not occur
Autocorrelation test (dw)	2 < 2.329 < 4-dU			No autocorrelation

### Quadratic Functions Model Request for Production Costs

Results of calculation parameters for the function model of production costs youngest plywood in Java as follows:

$$C = 0,184 Z^2 - 118,592 Z + 309.317,9$$

(16,57)    (-2,06)    (4,727)  
 $R^2 = 0,977$        $F = 1693,033$

From the above calculation results of the tests of significance have fit both of t test, F and  $R^2$ . Similarly seen from the test results are in accordance both classical assumption of multicollinearity, heteroscedasticity and autocorrelation. More results as shown in the following table:

Multicollinearity test	0,968	t = 34.761	t-tab = 1.990	Multicollinearity occurred, but still good
Heteroskedasticity test (rS)	0,361	t = 3,484	t-tab = 1.990	Heteroscedasticity not occur
Autocorrelation test (dw)	2 < 2.304 < 4-dU			No autocorrelation

### Hypothesis Test Results Equation Dynamic Models

Internalization of Externalities Influence On The Level Gain plywood Export plywood industry youngest in Java to the United States.

Hypothesis: "Internalizing Externalities are the positive effect on the level of net exports of plywood youngest plywood Industry in Java to the United States"

Having regard to the pattern formation  $\pi(t)$  is defined by  $p(t)$ ,  $Z(t)$ , and  $C(t)$  then the hypothesis testing for the condition of *Fixed End Point Problem* and conditions of *Free Boundary Problems Right Hand* can be written:

$$\pi(t) = Z(t).p(t) - C(t) \quad (\text{Fix})$$

$$C(t) = 0,184 Z^2(t) - 118,592 Z(t) + 309.317,893$$

where:

$$Z(t) = -5,684 p(t) + 95,026 p'(t) + 6.077,001$$

$$p(t) = -0,119 e^{0,084t} - 86,263 e^{-0,084t} + 778,845$$

$$p'(t) = -0,010 e^{0,084t} + 7,217 e^{-0,084t}$$

and

$$\pi(t) = Z(t).p(t) - C(t) \quad (\text{Free})$$

with:

$$C(t) = 0,184 Z^2(t) - 118,592 Z(t) + 309.317,893$$

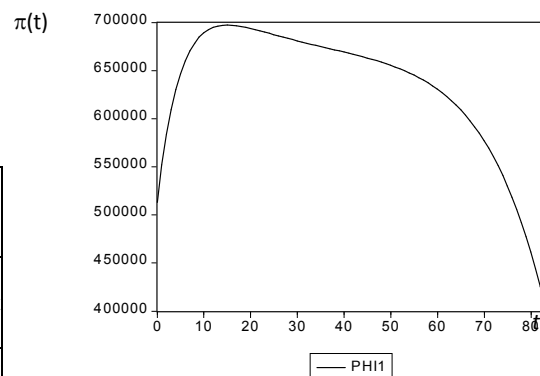
where:

$$Z(t) = -5,684 p(t) + 95,026 p'(t) + 6.077,001$$

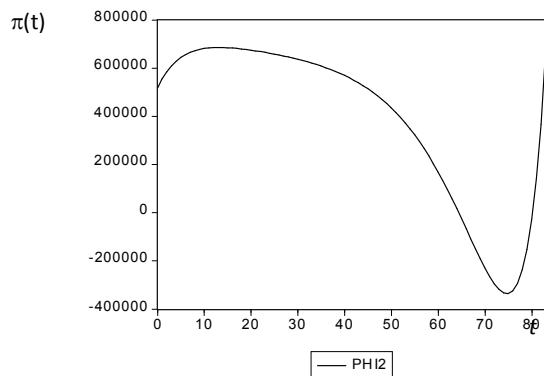
$$p(t) = -1,682 e^{0,084t} - 84,701 e^{-0,084t} + 778,845$$

$$p'(t) = -0,141 e^{0,084t} + 7,086 e^{-0,084t}$$

Based on the results of the regression  $\pi(t)$  values obtained  $\ell$ ,  $M$  and  $n$ , and  $a$ ,  $b$ ,  $c$ ,  $k_1$ ,  $k_2$ ,  $r$ , and  $g$  are consistently good in the conditions *fixed end point problem* and *Free Boundary Problems Right Hand*, with the level of suitability models  $R = 1$ .



(1)



(2)

Figure Relationship  $\pi t(t)$  on the condition of *Fixed End Point Problem (1)* and *Free Boundary Problem Right Hand (2)*

Relationship  $t$  to  $\pi(t)$ , both on condition *Fixed End Point Problem* and *Free Boundary Problems Right Hand*, has a positive direction up to a certain time limit, as shown in figure above. Thus, the research hypothesis is accepted, eco labeling positive influence on export profits labeled plywood industry plywood on Java to the United States.

## Discussion

### Fixed End Point Problem

In accordance with the calculation of the rate of profit trends show an increasing pattern and achieve the greatest value at  $t = 15$  or in the year 1996.04. Plywood industry capabilities in Java youngest highest profit was due to the carrying capacity of tropical forests are still extensive and a quota on making an impact on the price of round-wood logs are low so the cost is also low making plywood. On the other hand U.S. consumers are willing to pay a premium green with the internalization of environmental factors due to the implementation of the internalization of externalities that encourage increased levels of profit by the youngest plywood industry in Java.

Further at  $t = 16$  to  $t = 76$  the youngest plywood industry profits in Java started to decline but still larger than the initial gains. Decline in profit at  $t = 16$  is caused by two factors. First, because of the U.S. reliance on youngest plywood industry on Java, the demand for exports made to order. By doing internalize externalities due to a decline in export volume to deal with the scarcity of raw materials due to rainforest destruction in Indonesia. Second, efforts to improve the quality of products in response to the internalization of

externalities with respect to waste management and efficiency of the production process have significantly reduced profit.

In more remote advantages youngest plywood industry in Java continues to decline until  $t = 96$  due to the high environmental costs should be internalized as a result of the destruction of tropical forests because there is no guarantee the implementation of the government internalize externalities. Even after  $t = 96$  plywood industry suffered losses due to internalize externalities. This suggests that the implementation of the internalization of externalities is not just the responsibility of governments and industrialists but also stakeholders. If possible amount plywood industry should be reduced especially inefficient. In this way, the volume of Indonesia's plywood exports to the United States may be declining, but efficient industries acted as the youngest of plywood industry in Java will feel the benefits due to internalize externalities.

After  $t = 111$  predicted youngest plywood industry on Java would receive benefits that tend to increase due to internalize externalities. The increase in profits due to the good cooperation between the plywood industry in the United States. Moreover proven youngest plywood industry on Java conditions is still better than other plywood industry even though a large capacity. Means the implementation of internalizing externalities still provide prospects for industrial development plywood industry labeled as youngest plywood industry in Java.

### Free Boundary Problems Right Hand

Based on the results of trend equation plywood industry profit levels youngest in Java seems to have a pattern of increased then decreased and then increased again. Increased profitability due to internalize externalities occurs from  $t = 0$  to  $t = 13$ . The increasing pattern suggests that the internalization of externalities positive effect on the level of export profits. After  $t = 13$  level of profits youngest plywood industry in Java began to decline.

Decline in profits caused a loss of  $t = 65$  to  $t = 80$ . The main factors that cause is the removal of the log export ban in Indonesia, which adversely affects the production potential of the forest. This condition is circumvented by the youngest plywood industry on Java with more productive actions that increase the innovative actions in penetrating export markets the United States. Starting with the seriousness of the World Bank on the importance of tropical forests in Indonesia as the lungs earth, the United States responded by boycotting the plywood industry in

Indonesia with the issue of tropical grounds. Nevertheless youngest plywood industry in Java still in production with deliveries of raw materials from the United States. This means an advantage for the youngest plywood industry in Java which still survives to meet the demand for plywood exports by the United States.

Increasing levels of awareness of the importance of tropical forests over plywood exports are also expected to be better and actually beneficial for the plywood industry as the youngest plywood industry labeled on Java. As seen in the long-term benefits  $t = 143$  youngest plywood industry in Java is a large increase. Ability youngest plywood industry in Java is supported by the following regulatory measures internalizing externalities ie by using the labeled timber and the U.S. response to the high non plywood products at a high price.

### Conclusion

From the processing and analysis of data on the above model can be concluded as follows: internalizing externalities positive effect on the level of net exports of labeled plywood by youngest plywood industry in Java to the United States.

### References

- [1] Agus Sari, *Indonesia Emission Reduction Commitments in 2020: 26-41% below BAU*, within <http://iklimkarbon.com/2010/02/24/komitmen-penurunan-emisi-indonesia>, date February 24, 2010
- [2] Asfia Murni, *Ekonomika Makro*, PT Refika Aditama, Bandung: 2013.
- [3] Emil Salim dan Dradjat Wibowo, *Joint Certification Protocol (JCP) between LEI-accredited Certification Bodies dan FSC-accredited Certification Bodies September 2000*, Seminar Paper on Implementasi Standar Sistem Manajemen Sebagai Pendorong Pencapaian Pengelolaan Hutan Secara Lestari; Pusat Standardisasi dan Lingkungan Kehutanan dan Perkebunan – Ex Dephutbun, Jakarta: 9 November 2000.
- [4] Maret Priyanta, Nadia Astriani dan Amiruddin A. Dajaan Imami, *Kebijaksanaan tentang Perubahan Iklim di Jawa Barat dalam Pembangunan Berkelanjutan*, in *Sosiohumaniora Journal* Vol.14 No.3, November 2012, Bandung: 2012.

[5] Nopirin, *Ekonomi Internasional*, BPFE – Yogyakarta : 1997

[6] Otto Soemarwoto, *Atur Diri Sendiri: Paradigma Baru Pengelolaan Lingkungan Hidup*, Gajah Mada University Press, third edition, 2004, p.63-64

[7] Sharad Adhikary (Perwakilan WHO untuk Indonesia), *Penyebab dan Dampak Perubahan Iklim Secara Global*, *Majalah Dokter Kita* Edisi Mei 2008, p.24.

[8] Susilo Bambang Yudoyono (Presiden RI), *Rencana Aksi Nasional Dalam Menghadapi Perubahan Iklim*, Kementerian Negara Lingkungan Hidup, Jakarta 2007, p.iii

# Volatility in Sectors and National Income: A Comparative Analysis of Pakistan and Korea

Rana Ejaz Ali Khan<sup>1</sup> and Nadia Mahtab<sup>1</sup>

*1 Department of Economics, The Islamia University of Bahawalpur, Bahawalpur, Pakistan.*  
[ranaejazalikhan@yahoo.com](mailto:ranaejazalikhan@yahoo.com) [nadiamahtab@hotmail.com](mailto:nadiamahtab@hotmail.com)

## Abstract

*The study empirically investigated the impact of sectoral volatility on economic growth of Pakistan and South Korea using annual time series data for the years 1971-2010. ADF unit root test is used to check the stationery of the data. Autoregressive Conditional Heteroscedasticity (ARCH) and General Autoregressive Conditional Heteroscedasticity (GARCH) have been used for estimating the volatility in variables included in the model. To see the impact of sectoral volatility Ordinary Least Square (OLS) has been used. Finally to investigate the stability in the model Cumulative sum (CUSUM) and Cumulative sum square (CUSUMSQ) tests have been employed. The results revealed that there exists almost equal level of volatility in GDP growth rate of both countries. However, volatility in agriculture, industry, services, exports and imports sector varies for two countries. Greater volatility shocks exist in agriculture sector as compared to South Korea. Volatility in industrial sector persists in both economies but not to the greater extent. Almost equal level of volatility shocks exist in services and import sector of both economies. However, export sector has shown greater volatility shocks in South Korea as compared to Pakistan. The results of regression analysis have shown that volatility in agriculture sector contributes more towards volatility in GDP growth in Pakistan as compared to South Korea. One of the obvious explanations may be that agriculture sector is the largest sector of the economy. The volatility in industrial sector almost equally contributes to volatility in GDP of both countries. On the other hand the volatility in services sector contributes more volatility of GDP in South Korea as compared to Pakistan. The volatility in export sector contributes to volatility in GDP of only Pakistan. Finally the volatility in imports sector negatively impacts the GDP volatility in Pakistan but positively in South Korea.*

## 1. Introduction

The growth of an economy depends on characteristics of different major sectors such as agriculture, industry, services etc. Due to structural changes in different sectors, volatility of growth rate has been experienced by the economies [1]. An important ingredient of development is growth stability, because development requires continuous increases in income. Instability becomes costly for

developing countries and it deters growth [2]. The instability in growth rate of economies is attributed to the increasing volatility in some major sectors. The analysis of their volatility can be useful in providing some enlightenment on the factors behind this phenomenon and its implication for the formulation of the policy. The share of agriculture sector in GDP has traditionally been dominated in a pre-industrialized economy while the other two (that is industrial and services) sector's shares remain comparatively modest. In the grown-up industrialized countries (for example Japan, U.S.A and certain member of the European countries) the benchmark for the share of agriculture sector in GDP has been as little as 2 percent, with the remaining shares of production originating from the industrial and service sectors [3].

In this study we will attempt to see the effect of sectoral volatility on volatility of economic growth of two countries, i.e. Pakistan and Korea. The core objective of the study is to probe that volatility of which sector contributes to the volatility of economic growth in both countries, and how the effect differs for these two economies.

## 2. Review of Literature

In the literature, there are evidences that the sectors in which economies specialize have a significantly large effect on production and trade of these economies [1,4]. Plethora of the studies has

probed the experience of volatility and its effect on economic performance of a country [2,5,6,7,8]. Some of the studies have found positive association between growth and volatility [1,8,9] while some found negative association between growth and volatility [5,10,11,12]. A puzzle exists in the literature due to these contradictory findings. These contradictions may arise due to varying estimation techniques, nature and structure of the economies and sectors as well as proxies and variable differences in the models.

Ramey and Ramey [5] investigated the cross country association between volatility and growth rate of economies. They simply calculated the mean and standard deviation of per capita annual growth rate over time period for each one country and found that economies by means of higher volatility had lower rate of economic growth. The study also revealed that the investment share of GDP played a little part in the association among volatility as well as growth. The negative impact of government spending volatility on economic growth was contradicted with the results of [13].

Azid, et al. investigated the impact of sectoral volatility on economic development for Pakistan. Volatility was checked by using conventional time-series techniques (i.e. a rolling variance of the series and GARCH). They found that every sector showed a significant impact on the volatility of output growth rate except financial sector. The study further revealed that there was no long run relationship between fluctuations of growth rate of output and volatility of growth rate of different sectors of the economy. Conversely, an association exists only for the short-run [7].

Imbs has investigated the relationship between sectoral fluctuations and economic growth across countries. Data used in the study included yearly value added of different sectors, employment and content of factor of production in manufacturing activities. The study concluded that fluctuated activities within economies grow rapidly and controlled high investment rate. It was also found that across countries the relationship between economic growth and volatility was positive while across sectors it was negative [8].

Koren and Tenreyro investigated volatility, diversification and development in the Gulf Cooperation Council (GCC) countries. The volatility was estimated as the deviation of output growth rate of a specified sector in a specified country from average growth rate over the time period. The study concluded that GCC countries were basically more

fluctuated as compared to other countries at the equal level of economic development and that was due to their strong dependence on oil. The positive covariance among sectoral shocks and country specific shocks was also found. The high levels of country specific fluctuation suggested that macroeconomic policy could be enhanced to further alleviate volatility [9].

In nutshell, various studies have applied different econometric techniques to find the association between volatility and economic growth. We are focusing on the comparative analysis of volatility effect of some sectors of Pakistan and South Korea on fluctuation of their GDP growth rates respectively using the same time period data.

### 3. Methodology

Annual time series data has been analyzed for the years 1971-2010 taken from World Development Indicators. Time-series data often contains a unit root or is non-stationary. Ordinary least square estimates are useless if in a model all the variables are non-stationary on level or if integration orders of all the variables are not zero. To check stationary properties of time-series data (ADF) unit root test has been applied. Volatility of the variables under discussion, i.e. growth rate of output, growth rate of value added of agriculture, growth rate of value added of industry, growth rate of value added of services, growth rate of exports, and growth rate of imports is examined by applying Autoregressive Conditional Heteroscedasticity (ARCH) and Generalized Autoregressive Conditional Heteroscedasticity (GARCH). After estimating volatility of all the variables Ordinary least square method is used to check the relationship between volatility in growth of different sectors and volatility in growth of output in both countries. We performed this analysis in two steps. In the first step volatility of growth of each sector is regressed over the volatility of growth rate of output. In the second step, volatility in all the variables has been regressed on volatility of growth rate of output. Furthermore, to check stability of our model we employed cumulative sum (CUSUM) and cumulative sum of squares (CUSUMSQ) tests. The operational definitions of the variables have been given in table-1.

**Table-1: Operational Definitions of the Variables**

Variables	Operational Definitions
-----------	-------------------------

GR_Y (Growth rate of output)	Annual percentage growth rate of Gross Domestic Product (GDP) at market prices based on constant local currency
GR_AGR (Growth rate of value added of agriculture)	Annual growth rate for agricultural value added based on constant local currency
GR_IND (Growth rate of value added of industry)	Annual growth rate for industrial value added based on constant local currency
GR_SER (Growth rate of value added of services)	Annual growth rate for value added in services based on constant local currency
GR_EXP (Growth rate of exports)	Annual growth rate of exports of goods and services based on constant local currency
GR_IMP (Growth rate of imports)	Annual growth rate of imports of goods and services based on constant local currency

To check volatility in the variables GARCH (1,1) model (Bollerslev 1986) is used. General form of GARCH (p, q) model is:

$$Y_t = \alpha + \beta X_t + u_t$$

$$u_t | \Omega_t \sim N(0, h_t)$$

$$h_t = \gamma_0 + \sum_{i=1}^p \delta_i h_{t-i} + \sum_{j=1}^q \gamma_j u_{t-j}^2$$

which says that the value of  $h_t$  (i.e. variance parameter) depends on past values of the shocks (expressed by the lagged squared residuals terms) and on past values of variance (expressed by lagged  $h_t$  terms). GARCH (1, 1) is the simplest form of GARCH (p, q) model. Variance equation for GARCH (1,1) model is:

$$h_t = \gamma_0 + \delta_1 h_{t-1} + \gamma_1 u_{t-1}^2$$

Where p shows the order of GARCH term and q shows the order of ARCH term. In our model variance equations for growth rate of output of Pakistan and Korea are:

$$GR\_Y_{Pak} = \beta_0 + \beta_1 GR\_Y_{t-1} + u_t \dots (1)$$

$$GR\_Y_{Kor} = \pi_0 + \pi_1 GR\_Y_{t-1} + u_t \dots (2)$$

For both countries GARCH (1,1) model is applied to estimate the volatility in growth of different sectors.

Ordinary Least Square (OLS) methods for Pakistan and Korea are as:

$$VOL\_Y_{Pak} = \beta_0 + \beta_1 VOL\_AGR + \beta_2 VOL\_IND + \beta_3 VOL\_SER + \beta_4 VOL\_EXP + \beta_5 VOL\_IMP \dots (3)$$

$$VOL\_Y_{Kor} = \pi_0 + \pi_1 VOL\_AGR + \pi_2 VOL\_IND + \pi_3 VOL\_SER + \pi_4 VOL\_EXP + \pi_5 VOL\_IMP \dots (4)$$

Where

$VOL\_Y$  = Volatility of Growth rate of output

$VOL\_AGR$  = Volatility of Growth rate of value added of Agriculture

$VOL\_IND$  = Volatility of Growth rate of value added of Industry

$VOL\_SER$  = Volatility of Growth rate of value added of Services

$VOL\_EXP$  = Volatility of Growth rate of Exports

$VOL\_IMP$  = Volatility of Growth rate of imports

#### 4. Empirical Results

To check the stationarity of the time series ADF unit root test has been applied on all the variables for Pakistan and South Korea. The results of ADF unit root test of all the variables about Pakistan and South Korea are reported in table 2 and 3 respectively. The results express that all the variables for Pakistan and Korea are stationary at level, with intercept, and with trend and intercept. It means that all of the variables are integrated of order zero or I (0) for both countries.

**Table-2: Unit Root Test of variables for Pakistan**

ADF Statistics				
Variables	Intercept	Trend and Intercept	None	
	Level	Level	Level	First Difference
GR_Y	-4.846	-4.964	-1.436	-10.172
GR_AGR	-8.098	-7.966	-0.926	-7.429
GR_IND	-5.127	-3.679	-0.635	-3.119
GR_SER	-4.230	-4.769	-1.343	-7.230
GR	-	-	-	-8.398

EXP	6.355	6.300	5.202	
GR_I MP	- 5.799	- 5.636	- 5.368	-8.265
Critical values (1%)	- 3.610	- 3.211	- 2.625	-2.628
Critical values (5%)	- 2.938	- 3.529	- 1.949	-1.950
Critical values (10%)	- 2.607	- 3.196	- 1.611	-1.611

When unit root is applied on without trend and intercept data is stationary at first difference for both countries. This means that without trend and intercept data of the variables is integrated of order one or I (1).

**Table-3: Unit Root Test of variables for Korea**

ADF Statistics				
Variables	Intercept	Trend and Intercept	None	
	Level	Level	Level	First Difference
GR_Y	- 4.979	- 5.672	- 0.859	-6.128
GR_AGR	- 9.618	- 5.537	- 8.376	-6.432
GR_I ND	- 4.471	- 5.580	- 1.741	-5.708
GR_SER	- 4.029	- 4.506	- 1.062	-9.590
GR_EXP	- 4.994	- 5.472	- 2.737	-8.732
GR_I MP	- 6.273	- 6.467	- 1.826	-6.597
Critical values (1%)	- 3.610	- 4.211	- 2.632	-2.632

Critical values (5%)	- 2.938	- 3.529	- 1.950	-1.950
Critical values (10%)	- 2.607	- 3.196	- 1.611	-1.611

The results of ADF unit root test for volatility in all the variables for Pakistan and Korea are reported in table 4 and 5 respectively.

**Table-4: Unit Root Test of the Volatility in variables for Pakistan**

ADF Statistics			
Variables	Intercept	Trend and Intercept	None
VOL_Y	-8.426	-8.895	- 8.522
VOL_AG R	-6.045	-5.953	- 6.069
VOL_IN D	-5.105	-5.114	- 6.589
VOL_SE R	-6.322	-6.743	- 6.335
VOL_EX P	-6.150	-6.055	- 6.160
VOL_IM P	-6.684	-6.556	- 6.741
Critical values (1%)	-3.615	-4.219	- 2.627
Critical values (5%)	-2.941	-3.533	- 1.949
Critical values (10%)	-2.609	-3.198	- 1.611

**Table-5: Unit Root Test of the Volatility in Variables for Korea**

ADF Statistics			
Variables	Intercept	Trend and Intercept	None
VOL_Y	-5.762	-6.619	- 5.795
VOL_AG R	-4.757	-4.803	- 4.793
VOL_IN D	-5.489	-6.196	- 5.567
VOL_SE R	-5.970	-6.656	- 6.053



VOL_EX	-5.667	-5.881	-
P			5.737
VOL_IM	-5.463	-5.850	-
P			5.539
Critical values (1%)	-3.615	-4.219	-
			2.627
Critical values (5%)	-2.941	-3.533	-
			1.949
Critical values (10%)	-2.609	-3.198	-
			1.611

The results of table 4 and 5 show that with intercept or with trend and intercept or without trend and intercept all the variables are stationary at level or I (0) i.e. integrated of order zero.

#### 4.1 Empirical Results of Volatility in Variables from ARCH GARCH Process

Empirical results obtained from ARCH GARCH process are reported in Table 6 and 7 for Pakistan and Korea.

In case of Pakistan variance equation for GR\_Y<sub>Pak</sub> is:

$$h_t = 0.41832 + 1.1576 h_{t-1} - 0.20277 u_{t-1}^2 \dots \dots \dots (5)$$

and in case of South Korea variance equation for GR\_Y<sub>Kor</sub> is:

$$h_t = 0.26624 + 1.16574 h_{t-1} - 0.19411 u_{t-1}^2 \dots \dots \dots (6)$$

Empirical results that reported above are obtained from GARCH (1, 1) model. For convenience we denoted ARCH parameter by  $\alpha$  and GARCH parameter by  $\beta$ . To check volatility add the ARCH and GARCH coefficients ( $\alpha + \beta$ ). If the sum is very close to 1, then it indicates that volatility shocks are persistent to the greatest extent and if the sum is very close to 0 then it indicates that there is no persistent of volatility shocks. Variance equation (5) and (6) shows that the sum of the lag squared error term and lagged value of variance i.e. ( $\alpha + \beta$ ) is equal to 0.95483 and 0.97163 respectively, which indicated the volatility shocks in output growth rate of Pakistan and Korea are persistent to a greater extent. The estimates of ARCH and GARCH coefficients are also highly significant.

Variance equation for GR\_AGR<sub>Pak</sub> is:

$$h_t = 1.51948 + 1.10551 h_{t-1} - 0.23768 u_{t-1}^2 \dots \dots (7)$$

and variance equation for GR\_AGR<sub>Kor</sub> is:

$$h_t = 0.26624 + 1.16574 h_{t-1} - 0.19411 u_{t-1}^2 \dots \dots (8)$$

Equation (4.3) and (4.4) shows that the sum of the lagged square error term and lagged value of variance is equal to 0.86783 and 0.97163, which indicated the volatility shocks in agriculture growth rate of Pakistan and Korea, are persistent. The estimates of ARCH and GARCH coefficients are also highly significant.

Variance equation for GR\_IND<sub>Pak</sub> is:

$$h_t = 3.75196 + 0.64601 h_{t-1} + 0.02583 u_{t-1}^2 \dots \dots \dots (9)$$

and variance equation for GR\_IND<sub>Kor</sub> is:

$$h_t = 18.948 + 0.6609 h_{t-1} - 0.15600 u_{t-1}^2 \dots \dots \dots (10)$$

Equation (9) and (10) shows that the sum of the lagged square error term and lagged value of variance is equal to 0.67184 and 0.5049 respectively, the estimates of ARCH and GARCH coefficients are statistically insignificant in case of Pakistan, shows that the conditional variance of GR\_IND is not affected by lag squared stochastic term. But estimates of ARCH and GARCH coefficients are statistically significant in case of Korea.

Variance equation for GR\_SER<sub>Pak</sub> is:

$$h_t = 0.11619 + 1.13293 h_{t-1} - 0.16663 u_{t-1}^2 \dots \dots \dots (11)$$

and variance equation for GR\_SER<sub>Kor</sub> is:

$$h_t = -0.3252 + 1.20465 h_{t-1} - 0.22158 u_{t-1}^2 \dots \dots \dots (12)$$

Variance equation (11) and (12) shows that the sum of the lagged square error term and lagged value of variance is equal to 0.9663 and 0.98307 respectively, which indicated the volatility shocks in growth rate in value added of services are persistent to a greater extent. The estimates of ARCH and GARCH coefficients are also statistically significant in case of both countries.

Variance equation for GR\_EXP<sub>Pak</sub> is:

$$h_t = 91.4484 + 0.62807 h_{t-1} - 0.25416 u_{t-1}^2 \dots \dots (13)$$

and Variance equation for GR\_EXP<sub>Kor</sub> is:

$$h_t = 6.9243 + 1.0742 h_{t-1} - 0.20154 u_{t-1}^2 \quad (14)$$

Variance equation (13) and (14) shows that the sum of the lagged square error term and lagged value of variance is equal to 0.37391 and 0.87266 respectively, which indicated the volatility shocks in growth rate exports are not much more persistent in case of Pakistan. The estimates of ARCH and GARCH coefficients are also statistically significant.

Variance equation for  $GR\_IMP_{Pak}$  is:

$$h_t = 23.1593 + 1.08164 h_{t-1} - 0.25387 u_{t-1}^2 \quad (15)$$

and variance equation for  $GR\_IMP_{Kor}$  is:

$$h_t = 8.3998 + 1.0899 h_{t-1} - 0.1083 u_{t-1}^2 \dots \dots \dots (16)$$

Equation (15) and (16) shows that the sum of the lagged square error term and lagged value of variance is equal to 0.8277 and 0.9816 respectively, which indicated the volatility shocks in growth rate of imports are persistent. The estimates of ARCH and GARCH coefficients are also statistically significant.

**Table 6: Variance obtain from GARCH (1, 1) Model for Pakistan**

Variable	Coefficient	z-statistic	Prob.
<b>Dependent variable: GR_Y<sub>Pak</sub></b>			
<b>Variance Equation</b>			
Const	0.4183	4.197	0.0
nt	2	325	000
RESID (-1)^2	0.20277	318554	0.0
GARCH H(-1)	1.1576	16.61	0.0
		87	000
<b>Dependent variable: GR_AGR<sub>Pak</sub></b>			
<b>Variance Equation</b>			
Const	1.5194	1.775	0.0
nt	8	6	758
RESID (-1)^2	0.23768	2.5206	0.0
GARCH H(-1)	1.1055	29.40	0.0
	1	14	000
<b>Dependent variable: GR_IND<sub>Pak</sub></b>			
<b>Variance Equation</b>			
Const	3.7519	0.323	0.7
nt	6	15	466
RESID (-1)^2	0.0258	0.084	0.9
GARCH H(-1)	0.6460	0.564	0.5
	1	33	725
<b>Dependent variable: GR_SER<sub>Pak</sub></b>			

<b>Variance Equation</b>			
Const	0.1161	1.108	0.2
nt	9	72	675
RESID (-1)^2	0.16663	1.93261	0.0
GARCH H(-1)	1.1329	9.532	0.0
	3	39	000
<b>Dependent variable: GR_EXP<sub>Pak</sub></b>			
<b>Variance Equation</b>			
Const	91.448	1.799	0.0
nt	4	61	719
RESID (-1)^2	0.25416	2.64880	0.0
GARCH H(-1)	0.6280	1.748	0.0
	7	88	803
<b>Dependent variable: GR_IMP<sub>Pak</sub></b>			
<b>Variance Equation</b>			
Const	23.159	0.894	0.3
nt	3	56	710
RESID (-1)^2	0.25387	2.75603	0.0
GARCH H(-1)	1.0816	4.812	0.0
	4	53	000

\* represents 5 percent level of significance and \*\* represents 10 percent level of significance

**Table 7: Variance obtain from GARCH (1, 1) Model for South Korea**

Variable	Coefficient	z-statistic	Prob.
<b>Dependent variable: GR_Y<sub>Kor</sub></b>			
<b>Variance Equation</b>			
Const	0.26624	0.08	0.9
nt		485	324
RESID (-1)^2	-0.19411	-	0.0
GARCH H(-1)	1.16574	4.13	0.0
		717	000
<b>Dependent variable: GR_AGR<sub>Kor</sub></b>			
<b>Variance Equation</b>			
Const	9.22264	0.39	0.6
nt		134	955
RESID (-1)^2	0.21266	0.49	0.6
GARCH H(-1)	0.53168	0.57	0.5
		478	654
<b>Dependent variable: GR_IND<sub>Kor</sub></b>			
<b>Variance Equation</b>			
Const	18.9485	2.51	0.0
nt		031	121
RESID	-0.15600	-	0.0

(-1)^2		3.23364	012
GARC	0.66090	3.11	0.0
H(-1)		169	019
<b>Dependent variable: GR_SER<sub>Kor</sub></b>			
<b>Variance Equation</b>			
Const	-0.32524	-	0.7
nt		0.29942	646
RESID	-0.22158	-	0.1
(-1)^2		1.34765	778
GARC	1.20465	4.11	0.0
H(-1)		883	000
<b>Dependent variable: GR_EXP<sub>Kor</sub></b>			
<b>Variance Equation</b>			
Const	6.92433	11.7	0.0
nt		476	000
RESID	-0.20154	-	0.0
(-1)^2		3.32910	009
GARC	1.07427	11.0	0.0
H(-1)		645	000
<b>Dependent variable: GR_IMP<sub>Kor</sub></b>			
<b>Variance Equation</b>			
Const	8.39981	2.89	0.0
nt		218	038
RESID	-0.18308	-	0.0
(-1)^2		3.96707	001
GARC	1.08991	21.4	0.0
H(-1)		668	000

### 5.1 Empirical Results Based on Regression Analysis

To check the relationship between volatility in growth rate of different sectors and volatility in GDP growth rate for Pakistan and South Korea OLS model is applied. The results of regression analysis are presented in Table 6 and 7. First we have regressed all explanatory variables separately, i.e. bivariate regression analysis and then regress multivariate regression analysis. Dependent variable is volatility in GDP growth rate and independent variables are volatility in growth rate of different sectors.

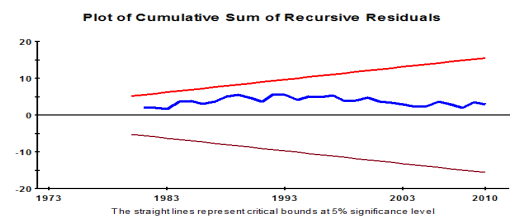
**Table-8: Regression Analyses of Volatility for Pakistan and Korea**

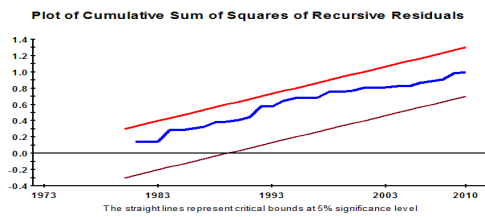
Model	Pakistan		South Korea	
	Coefficient (Prob.)	t - values	Coefficient (Prob.)	t - values

Constant	-	-	-	-
	0.047 (0.848)	0.19 2	0.336 (0.006)	2.8 85
VOLT_GR_AGR	0.201 (0.009)	2 .778	0.0 95 (0.000)	4 .71 9
VOLT_GR_IND	0.249 (0.001)	2 .456	0.2 07 (0.000)	1 0.4 39
VOLT_GR_SER	0.285 (0.019)	3 .434	0.7 51 (0.000)	5 .34 3
VOLT_GR_EXP	0.035 (0.080)	1 .801	- 0.017 (0.199)	- 1.3 08
VOLT_GR_IMP	- 0.033 (0.080)	- 1.80 0	0.0 59 (0.002)	- 2.8 86
	<b>R<sup>2</sup> = 0.582</b>		<b>R<sup>2</sup> =</b>	
	<b>Adj. R<sup>2</sup> =</b>		<b>0.966</b>	
	<b>0.519</b>		<b>Adj. R<sup>2</sup></b>	
	<b>F-stat =</b>		<b>= 0.961</b>	
	<b>9.194</b>		<b>F-stat =</b>	
			<b>189.71</b>	
<b>Dependent Variable: VOLT GR Y</b>				

Results obtained from regression analysis of both countries show that each variable has a significant impact on volatility in GDP when bivariate or multivariate regression is done.

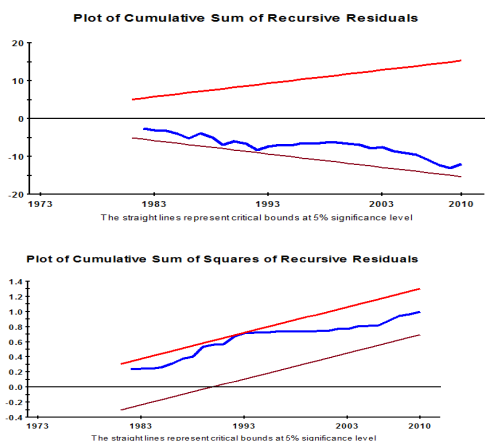
**Figure-1: CUSUM Charts for Pakistan**





In order to investigate the stability our model along with volatility parameters we employed Cumulative sum (CUSUM) and cumulative sum of squares (CUSUMSQ) tests. Pesaran, et al. (1999, 2001) proposed CUSUM and CUSUMSQ tests for estimating the stability of long and short run estimate. Figures 1 and 2 indicate that plots for CUSUM and CUSUMSQ are between the critical boundaries at 5% level of significance in case of Pakistan.

**Figure-2: CUSUM Charts for Korea**



Furthermore, figures 3 and 4 indicate that plots for CUSUM and CUSUMSQ are between the critical boundaries at 5% level of significance in case of South Korea. This demonstrates the accuracy of model in case of both countries.

## 5. Discussion

### 5.1 Volatility of Growth in Agriculture Sector

Growth rate of value added of agriculture is positively related to volatility in growth rate of output. The results show that in Pakistan 20 percent increase in volatility of growth rate of output is caused by volatility in growth rate of agricultural sector while in Korea 9 percent increase in volatility of growth rate of output is caused by volatility in growth rate of agricultural sector. It means that for

both countries volatility shocks in agriculture sector has significantly affected the volatility in output. Higher volatility is shown in the case of Pakistan. It may be due to the fact that the share of agriculture sector in GDP is higher in Pakistan as compared to Korea. Furthermore, the share of value added of agriculture in GDP has been significantly declining in Korea [14]. As compared to industrial and services sector, agriculture is slow-moving sector of the economy.

### 5.2 Volatility of Growth in Industrial Sector

Industrial growth has a vital role in the economic growth of countries like Indonesia, China, Taiwan and Korea. Volatility in growth rate of industry is positively related to volatility in growth of GDP. The results show that 24 percent increase in volatility of GDP growth is caused by volatility in industrial sector growth in Pakistan while in Korea 20 percent increase in volatility of GDP is caused by volatility in growth of industrial sector. It means that volatility shocks in industry have significantly affected the volatility in GDP. It explains that industrial sector is still the “engine” of economic growth [15]. The volatility in growth rate of industry increases the probability for GDP to be volatile. The results are supported by the studies for Pakistan and Indonesia [8,16].

### 5.3 Volatility of Growth in Services Sector

The role of labor force services in economic growth has been empirically evidenced by a number of studies like Linden and Mahmood [14] along with theoretical support from Kuznet [17]. Our results have shown that in Pakistan approximately 29 percent increase in volatility of GDP growth rate is caused by volatility in services sector while in Korea 75 percent increase in volatility of growth of output is caused by volatility in growth of services sector. It explains that volatility shocks in services sectors have more effect on volatility of growth of output in South Korea as compared to Pakistan. The explanation may be that services sector contribute highest ratio to GDP in Korea. The services sector has also strong associations to other economic sectors. It provides necessary inputs to agriculture as well as manufacturing sector for Pakistan [18]. If services sector is volatile there is volatility of volatility of GDP growth rate. Our results further revealed that volatility in growth of services sector contributes

highest to volatility in growth of output in both Korea and Pakistan [8].

#### **5.4 Volatility of Growth in Exports**

The literature generally agreed that exports benefit economic growth [19]. Our results have shown that in Pakistan 3 percent increase in volatility of growth of output is caused by volatility in growth of exports. This means that volatility shocks in growth of exports has significantly affected the volatility of growth of output. However, volatility in growth rate of exports contributes lowest to volatility of growth rate of output. This may be due to the fact that in case of Pakistan share of exports in GDP is comparatively lower than other sectors like agriculture. The empirical findings also revealed that in case of Pakistan exports share have an indirect effect on economic growth. Exports firstly affect imports and then imports influence the income.

#### **5.5 Volatility of Growth in Imports**

Volatility shocks in growth rate of imports have significantly affected the volatility of growth rate of output. The multivariate analysis has shown that 5 percent increase in volatility of growth of output is caused by volatility in growth of imports in Korea. It may be due to the fact that in economic growth imports play an important role through different channels. The volatility in imports sector increases the volatility in GDP. For Pakistan our results have shown that 3 percent decrease in volatility of growth of output is attributed to 1 percent increase in volatility of growth of imports. It revealed a negative relationship between volatility in growth of imports and volatility in growth of output. It may be due to the fact that Pakistan's imports are highly concentrated with raw material like machinery, petroleum and petroleum products, chemicals, edible oil, transport equipment, iron and steel and fertilizer. The raw material is used in industrial sector for production of final goods, the volatility in imports is causing decrease in volatility of growth rate of output.

### **6. Conclusion and Policy Recommendation**

On the basis of our results we conclude that there exists approximately equal volatility in GDP growth of both countries. The agriculture growth rate greater

volatility shocks in Pakistan as compared to South Korea. Volatility in growth of industry indicated the existence of volatility shocks but not to a greater extent in both countries. Volatility coefficient of growth rate in services sector indicated the existence of approximately equal volatility shocks in both of Pakistani and Korean economies. Volatility in growth rate of exports indicated existence of more volatility shocks in Korea than Pakistan. The volatility in growth of imports indicated the existence of approximately equal volatility shocks in Pakistan and Korea.

To check the effects of sectoral volatility on economic growth rate of both countries we applied regression analysis in two steps. In first step we applied bi-variate regression analysis, and in second step we applied multivariate regression analysis. On the basis of empirical results of regression analysis for both countries we conclude that either we regress bi-variate or multivariate regression analysis volatility in growth rate of agriculture sector contributes more to volatility in GDP growth of Pakistan than to Korea.

Results of volatility in industry show that when we regress bivariate regression analysis it contributes more to volatility in output in Korea and when we regress multivariate regression analysis then there is approximately equal contribution of volatility in industrial sector to volatility in growth rate of output in both countries.

Results show that either we applied bivariate or multivariate regression analysis volatility in growth rate of services sector contributes more to volatility in growth rate of output in Korea than Pakistan.

When we regress bivariate regression analysis volatility in growth rate of exports contributes more to volatility in growth rate of output in Korea than Pakistan. However multivariate analysis has shown positive effect in Pakistan only.

The bivariate regression analysis shows that the volatility in growth of imports contributes significantly to volatility in growth of output in both countries, but significantly higher in Korean economy. However, the results of multivariate regression show that volatility in growth of imports effect volatility in growth of output negatively in Pakistan while positively in Korea.

The volatility of services sector is causing high volatility in GDP growth in Pakistan as well as Korea. So it's not surprising, because empirical evidence prove that the share of services sector increases as the economy passes through the stages of

development. There is a need to stabilize the services sector, which will contribute to stabilize economic growth rate of output. It may be recommend that there is need to equip labor force with education, skill and advance technical knowhow which reduces the unemployment and increases the productivity. Information technology may be a good tool to equip the labor force and stabilize the services sector and consequently the GDP growth. Human resource development should be stressed in other areas like health and nutrition.

The volatility of agriculture sector is causing relatively high volatility in GDP growth rate in Pakistan than in Korea. There is need to stabilize the agricultural sector in Pakistan. It may be recommend to establish linkage industries and to provide advance technology to this sector. There is also need to stabilize the industrial sector because it also contributes in volatility of GDP growth of both countries. The imports are negatively affecting volatility in GDP growth in Pakistan. Raw material requirements comprising chemicals, fertilizers and cotton are fulfilled by imports if they are not flexible to the requirements the GDP will fluctuate. If the imports are fixed by quota or tariff the GDP will fluctuate. The notion ultimately supports the proponents of WTO and globalization.

## References

- [1] Koren, M. and Tenreyro, S. Volatility and Development. Centre for Economic Policy Research. 2005. 5307.
- [2] Mobarak, A. M. Democracy, Volatility, and Economic Development. *The Review of Economics and Statistics*. 2005. 87(2): 348-361.
- [3] Dutta, M. The Asian Economy and Asian Money. 2009. Emerald Group.
- [4] Krishna, P. and Levchenko, A. A. Comparative Advantage, Complexity, and Volatility. *Working Paper*. 2009. National Bureau of Economic Research. 14965.
- [5] Ramey, G. and Ramey, V. A. Cross-Country Evidence on the Link Between Volatility and Growth. *The American Economic Review*. 1995. 85(5):1138-1151.
- [6] Hnatkovska, V. and Loayza, N. Volatility and Growth. Policy Research Working Paper Series. The World Bank. 2003. 3184:1-40.
- [7] Azid, T., Khaliq, N. and Jamil, M. Sectoral Volatility, Development and Governance: A Case Study of Pakistan. *The Pakistan Development Review*, 2006. 45 (4):797-817.
- [8] Imbs, J. Growth and Volatility. *Journal of Monetary Economics*. 2007. 54:1848-1862.
- [9] Black, F. *Business Cycles and Equilibrium*. 1987. Cambridge, MA: Blackwell.
- [10] Bernanke, B. S. Irreversibility, Uncertainty, and Cyclical Investment. *Quarterly Journal of Economics*. 1983. 98(1):85-106.
- [11] Pindyck, R. S. Irreversibility, Uncertainty, and Investment. *Journal of Economic Literature*. 1991. 29 (3):1110-48.
- [12] Aizenman, J. and Marion, N. Policy Uncertainty, Persistence and Growth. *Review of International Economics*. 1993. 1(2):145-63.
- [13] Alesina, A., Ozler, S., Roubini, N. and Swagel, P. Political Instability and Economic Growth. Working Paper. (1992) National Bureau of Economic Research. 4173.
- [14] Kniivila, M. Industrial Development and Economic Growth: Implications for Poverty Reduction and Income Inequality. Working Paper. 2007. Department of Economic and Social Affairs. United Nations.
- [15] Linden, M. and Mahmood, T. Long Run Relationships Between Sector Shares and Economic Growth—A Panel Data Analysis of the Schengen Region. *Discussion Paper. University of Joensuu*. 2007. 50:1-36.
- [16] Medyawati, H. and Yunanto, M. The Role of Banking, Agriculture and Industrial Sector in Economic Growth in Indonesia. *Conference Paper. International Conference on Economics and Business Information*. 2011. 9.
- [17] Kuznets, S. Quantitative Aspects of the Economic Growth of Nations: II, Industrial Distribution of National Product and Labour

Forces. *Economic Development and Cultural Change*. 1957. 4.

[18] Ahmed, A. and Ahsan, H. Contribution of Services Sector in the Economy of Pakistan. Working Paper. Pakistan Institute of Development Economics. 2011. 79.

[19] Fosu, A. K. Export Composition and the Impact of Export on Economic Growth of Developing Economies. *Economic Letters*. 1990. 34: 67-71.

# International Cooperation of Infrastructure Development in the Era of Regional Autonomy in Indonesia

*Wasifah Hanim*

Widyatama University, Indonesia  
[Wasifah.hanim@widyatama.ac.id](mailto:Wasifah.hanim@widyatama.ac.id)

## *Abstract*

*Decentralization Era and regional autonomy in Indonesia has been running for 13 years, in this era provides an opportunity for all districts and provinces to accelerate development by utilizing its potential and fiscal capabilities. Objective conditions indicate that the region's ability to implement development is very diverse, it is because of differences in source revenue, human resources and natural resources, and so on. On the other hand local government has an obligation to provide services based on minimum service standards set by the central government. Therefore, inter-regional cooperation in infrastructure development becomes an important issue in improving the quality of public services. Cooperation urban areas as part of inter-regional cooperation has been loaded explicitly in the Act No. 32 of 2004 On Local Government. However, after more than one decade running yet many districts / cities that utilize urban cooperation in an effort to improve the quality of public services. Regulation of the Minister of Home Affairs (Permendagri) No. 69 at 2007 on Urban Development Cooperation explicitly cooperation procedures and types of public infrastructure to cooperation are: Bus Station, Installation of Waste Water Treatment Plant (WWTP), landfill, waste, road network, public Transportation, Solid Waste Services, Rainwater Network, clean Water Services and public cemetery. This paper aims to provide arguments and descriptive analysis regarding urban development cooperation in the era of regional autonomy in Indonesia. The analysis was conducted on the implementation of regional autonomy in Indonesia, Regulation of urban development cooperation and best practice urban cooperation in DIY province.*

**Key Words:** *Urban Development Cooperation, Regional Autonomy*

## **1. Introduction**

Autonomy policies implemented since 1999 has placed the district (especially the district/city) as spearheading the implementation of public service function and development (Utomo Tri Widodo, 2005). Implementation of regional development based on the principles of autonomy, that contained in Autonomy Act Number 32 of 2004 on Regional Government. Based on the Act districts have authorized a large to manage the region all its potential resources. Along with broad authority, the district required to increase their independence and held a public service to the community in order to improve the welfare of society.

However, in improving the quality of public services, especially in infrastructure management there are interdependencies between regions to one another, especially in border areas. Thus the inter-regional cooperation can be an alternative innovation / concept based on considerations of efficiency and effectiveness, synergy and mutual benefit, especially in areas of interest to cross the area. In practice, many areas have not been used to implement a pattern of cooperation / partnership in the implementation of business development and / or specific areas of public service. Nevertheless, the concept of development interregional cooperation already designed as embryonic potential regional policies.

In the implementation of the interregional cooperation required intensive facilitation and coordination of central and provincial governments. The role of central government in this regard, especially to facilitate the management of public services infrastructure across administrative areas, in the form of coaching and facilitating of cooperation both technical and non-technical in many aspects of the autonomous regions under (Tjahjanulin Domai, 2011).



## 1. Conceptual Framework of Interregional Cooperations

Regional autonomy policies enacted by since the implementation of the Law of the Republic of Indonesia Number 22 of 1999 (in revised into the Act No. 32 of 2004) regarding regional autonomy, the policy is effectively implemented since 2001. In the era of decentralization Local Government have greater authority in developing its potential and improve the region's autonomy in carrying out development. One consequence of the implementation of regional autonomy, local governments are required give greater attention to the quality of basic public services.

On one side of the decentralization policy is expected to create the region more independence and initiative in developing the regional economy. But on the other hand can also foster local autonomy of local egoism counter-productive to the national economy. At the same time at the decentralization era demands the cooperation between local governments, especially with regard to the management of public infrastructure in the border areas. Therefore awareness of local government that continues on regional initiatives in the framework of the establishment of regional management would be a common need.

Intergovernmental cooperation must be based on mutual interests, therefore, it should be participatory and flexible to generate consensus. This consensus will be fail if no recognition of equality of autonomy, willingness each of the parties concerned. Thus, cooperation between governments is sort relationship. therefore it is horizontal relationships between regions, develop intergovernmental cooperation / partnership requires a strategy and a model that allows three or more local governments to generate cooperation. It is also functional to deal with the problems of urban structures and infrastructure (*Utomo Tri Widodo W. 2005*).

Cooperation can be increased or more effective in implementation if there are external support (eg in terms of funding) and public demand and support from the community. Though the two things are important, but the most important is the commitment of each of the relevant local government, which is a commitment to work together in dealing with the issues that have been agreed upon, and promote the common good more than the interests of each region. The commitment needs to be owned by officials, both at the level of technical, managerial, and leadership, so that the necessary measures, including the reduction of red tape in co-operation can be done to improve the effectiveness and efficiency of motion. Strategic issues

relating to the Regional Intergovernmental Cooperation urgency for this is (*Tarigan Antonius, 2009*):

### 1. Improved Public Service.

Inter-regional cooperation is expected to be one of the innovative methods to improve the quality and coverage of public services. Effectiveness and efficiency in the provision of public services and infrastructure such as education, health, clean water, and so on also become an important issue, especially in underdeveloped regions. Improvement of public services also include development infrastructure such as roads, power plants, and so on.

### 2. Border Regions

Cooperation in terms of security of border region is also one of the strategic issues. Besides that cooperation in border areas will encourage regional development, since the areas in the border regions mostly is underdeveloped regions.

### 3. Spatial Plan

Spatial linkages between regions is necessary in things that can affect more than one area, such as Watershed, protected areas, and so on.

### 4. Disaster Management and Potential Conflicts

Disaster mitigation efforts and post-disaster actions, when reflecting on the experience in NAD, Alor and Nabire, as well as other regions, it turns out this situation requires coordination and cooperation between adjacent regions.

### 5. Regional Disparities and Poverty Reduction

Limited ability, capacity and resources vary across the region raises the geographic disparities and poverty (social inequality). Through regional cooperation, is expected to increase local capacity in the use of resources in a more optimal and local economic development, in order to reduce poverty and reduce geographic disparities.

### 6. Enhancing the role of Provincial

The Act 32 of 2004 on Regional Government, suggest the need to increase the role of the province, including in facilitating the settlement of inter-regional issues. It is necessary to increase the ability of the province to organize / encourage inter-regional cooperation (local government cooperation). This role particularly in the capacity as an arm of the province and the central government as a facilitator and catalyst for Inter-Regional Cooperation.

### 7. Regional Expansion

Inter-regional Cooperation may be one alternative to improve the effectiveness and efficiency of public service in addition to the policy of regional expansion. This is because the division policy requires more resources than the Inter-Regional Cooperation,

and the development of new autonomous regions do not always give the results as desired.

Intergovernmental cooperation is a significant step, the government considerations in approving cooperation are as follows:

1. economies of scale, some of the services provided by the government to achieve economies of scale if average cost decline along with the increasing in volume of service. Example, in the area of public works, wastewater management, capital facilities, clean water, and waste disposal. The average cost usually reduced when produced with a larger scale.

2. the disparities distribution of natural resources such as soil, water, transportation and drainage.

3. Development of activities and services by local governments for public use that can not be limited by administrative region. Example is drainage, garbage disposal, roads, transportation, health care, and education.

In intergovernment cooperation, the important consideration is how to build consensus among relevant actors. Therefore, a flexible cooperation needed to open up opportunities of changes and adjustments for the implementation of cooperation. However, some of the obstacles that hinder the implementation of the cooperation as follow (Tjahjanulin Domai, 2011):

a. "Ego region" is very prominent for cooperation between local governments.

b. Mutual trust between actors cooperation.

c. Resource gap between local governments cooperating.

d. The desire to dominate from a region to another region in the decision about sector cooperation.

e. different visions and missions among local governments.

The Central Government has realized the importance of cooperation between regions in accelerating regional economic development. Formation KSN Based on Government Regulation No. 26 of 2008 on National Spatial Plan (RTRWN). There are 76 (seventy-six) national strategic area (KSN) is one implementation of inter-regional cooperation initiated by the Central Government, either already built, under construction, or are still in the planning stages of development. The locations of National Strategic Area are not specified in a particular administrative area but few are subsequently incorporated administrative region in the KSN, some urban areas of KSN are as follows:

**Table 1. National Strategic Area (KSN) in National Spatial Plan (RTRWN)**

Province	District area	Administrative area
North Sumatera	Mebidangro	Medan – Binjai – Deli – Serdang – Karo.
DKI – West Java - Banten	Jabodetabek	Dki Jakarta – Bogor – Depok – Tangerang – Bekasi.
West Java	Bandung Raya	Bandung – Bandung – Bandung Barat – Cimahi.
Central Java	Kedungsepur	Semarang – Kendal – Demak – Unggaran – Purwodadi.
Jawa Timur	Gerbangkertosu silo	Gresik – Bangkalan – Mojokerto – Surabaya – Sidoarjo – Lamongan.
Bali	Sarbagita	Denpasar – Bangli – Gianyar – Tabanan.
East Kalimantan	Sababote	Samarinda – Balikpapan – Bontang – Tenggarong.
South Sulawesi	Mamminasata	Makasar – Sungguminasa – Takalar – Maros.

Source: The government regulation Number 26 of 2008, was made;

### 3. Regulatory on Urban Cooperation

Under Article 195 of The Act No. 32 of 2004 on Regional Government states that in order to improve the welfare of the community and the provision of public services, interregional cooperation can develop with other regions or build a partnership with a third party that is based on consideration of the efficiency and effectiveness of public services, synergy and mutual profitable. In achieving these objectives there is the division of authority between the central, provincial and district. Based on Government Regulation No. 38 of 2007 on the coordination between Government, local government and the Provincial Government of the District / local. Government affairs can be divided into government affairs under the authority of the government (center) and government affairs under the authority of local governments.

Government affairs under the authority of the central government consists of foreign policy, defense, security, justice, monetary and fiscal policies as well as the national religion. Government affairs under the authority of local government consists of the obligatory functions and affairs of choice. Obligatory function of local government authority relating to basic services and relationships with the connect the development cooperation between the obligatory and the choice of local government cooperation with a group of urban objects.

**Table 2. Mandatory Affairs Local Government and Urban Development of Cooperation Objects**

No.	The compulsory business of county government (Based on government regulation number.38 in 2007)	The group city development of object cooperation (Government regulation number.69 in 2007)
1	Education	Culture Social
2	Health	Culture Social
3	Living environment	Layout and living environment
4	General public	Facility and infrastructure
5	Spatial management	Layout and living environment
6	Development planning	-
7	Residential	-
8	Youth and sport	-

No.	The compulsory business of county government (Based on government regulation number.38 in 2007)	The group city development of object cooperation (Government regulation number.69 in 2007)
9	Investment	-
10	Cooperative and small – medium businesses	-
11	Population and civil registration	Culture Social
12	Labor	-
13	Food resilience	-
14	Women Empowerment and children protection	-
15	Birth control and prosperous family	Culture Social (population)
16	Transportation	Facility of infrastructure
17	Informatics and communication	-
18	Agrarian	-
19	Entity nation and politic	-
20	Decentralization, public government, finance administration regional, county employe, employment kepegawaian	-
21	Society empowerment and rural	-
22	Social	Culture social
23	Culture	Culture social
24	Statistic	-
25	Archives and library	-

Source: Government regulation number.38 in 2007 and ministry regulation number.69 in 2007, was made ;

**Table 3. The Compulsory Affairs of Local government and the Urban development of Object Cooperation**

No.	The compulsory business of county government (Based on government regulation number.38 in 2007)	The group city development of object cooperation (Government regulation number.69 in 2007)
1.	Marine and fishery affairs	-
2.	Agrary	-
3.	Forestry	-
4.	Energy and mineral resources	-
5.	Tourism	Economic social
6.	Industry	Economic social
7.	Trading	Economic social
8.	Transmigration	-

Source: Government regulation number.38 in 2007 and ministry regulation number.69 in 2007, was made ;

The affairs of government are the potential to significantly improve the welfare of the community in accordance with the conditions, peculiarities and potentials in the regions concerned. The Procedures for Regional Cooperation stipulated in Government Regulation No. 50 of 2007. the Act states that the definition of inter-regional cooperation is an agreement between the governor and the governor or the governor with the regent / mayor or the regent / mayor with the regent / mayor or governor and the other, regent / mayor with a third party, which is formed in writing and creates rights and obligations. Cooperation is the subject of the Governor, the Regent, the Mayor, and the third party. While the object of the collaboration is all government matters that have become autonomous regional authority and may include the provision of public services.

Related to cooperation in the fields of infrastructure in border areas contained in Permendagri No. 69 of 2007 Regarding Urban Development Cooperation. The regulation states that urban development is an agreement of cooperation between regional heads and creates rights and obligations in the implementation of urban development. While the definition is the urban area that has a major non-agricultural activities in the area as a function of the composition of urban settlements, the concentration and distribution of government services, social services and economic activities.

The article explained that the various fields can be cooperated the object group development cooperation which includes the neighboring urban social and cultural fields; socio-economic; spatial planning and the environment, and facilities and infrastructure. Object cooperation in the provision of infrastructure or infrastructure is Terminal, Installation Water Treatment Plant (WWTP), Final Disposal (TPA) Waste, Roads, Public Transportation, Solid Waste Services, Rainwater Network, Clean Water Services and Public cemetery.

#### 4. Best Practice Urban Infrastructure of Kartamantul

Kartamantul urban cooperation is the cooperation undertaken by the Government of Bantul, Sleman and Yogyakarta City Government is one of the cooperation between regions that are "bottom up". In 1989, Technische Gesselchat for Zusammenarbeit (GTZ-UQ) as an urban development consultant introduced a concept of the Urban Agglomeration of Yogyakarta. This concept includes the city of Yogyakarta, Sleman and Bantul regency. This collaboration is an initiative to develop an integrated management of the city of Yogyakarta. In 1990, each regional head decided to form a task force to deal with urban problems Yogyakarta (Tjahjanulin Domai, 2011).

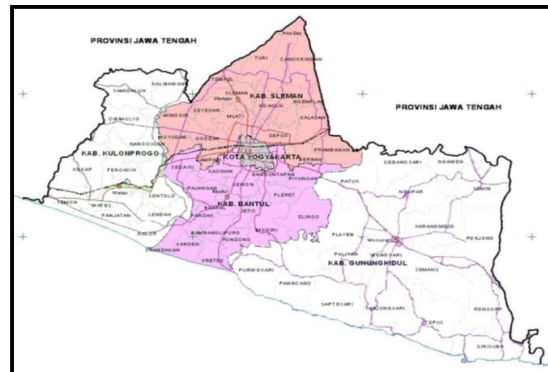


Figure 1. Kartamantul Urban Area

In this context, the exploration of the formation of local government cooperation agency showed two problems. The first is that the city of Yogyakarta to build the structure of water through the planning and the criteria are not in sync with Sleman and Bantul regency, and vice versa. The risk of flooding during the rainy season can not be avoided. Dealing with the problem of flooding, Sleman regency government to

develop the structure of water by channeling rain water to the River "belik". However, the city of Yogyakarta claims against it because it would inundate several parts that are lower in the city of Yogyakarta. Second, the development of urban areas in Yogyakarta has been extended to the area of Sleman and Bantul regency (Tjahjanulin Domai, 2011): .

Therefore urban system is created, as the Urban Agglomeration of Yogyakarta. Urban development and the provision of basic infrastructure can not be restricted by local government boundary. The second issue to encourage local governments Sleman, Bantul and Yogyakarta to develop cooperation in order to coordinate and synchronize the structure of urban development and infrastructure management. Cooperation is named "Kartomantul". the communication structure is developed as the gateway to the problems faced by the three local governments, called the Joint Secretariat Kartomantul.

Joint Secretariat for Development Cooperation Kartomantul a container Inter Regional Government of Yogyakarta, Sleman and Bantul, which has the main duty to assist the Governor of Yogyakarta Special Region to Implement the planning, execution, control, monitoring and evaluation of development programs in Region Yogyakarta, Sleman and Bantul. The Joint Secretariat is coordinating vehicle to optimize the integration of the management of urban infrastructure and the border region. HR managers of the Joint Secretariat (Joint Secretariat) Kartomantul are experts from the private sector where the recruitment process conducted openly.

HR managers Sekber Kartomantul by allowing private communication bridge between the head of the urban areas of cooperation actors in the DIY environment can run without bureaucratic atmosphere is thick with the values that are paternalistic. Thus in any discussion of matters relating to urban cooperation, for example, sharing the financing can be resolved without the interests of the area or ego.

Cooperation Facility Management and Urban Kartomantul facility 6 sectors ie sector includes waste management, water sector, drainage sector, Road Sector, wastewater Sector, and transportation sectors

1. Water sector, the aim is to satisfy the needs of water / clean water in urban areas of Yogyakarta. The scope and management of water services include: Development of water supply, construction of infrastructure and buildings and retrieval of raw water transmission pipelines, processing plant, transmission pipeline and reservoir water, establishment institution / organization and administration, finance and basic

tariff rates clean water and environmental management.

2. Drainage sector, infrastructure management and drainage facilities aimed to prevent flooding and eliminate standing water due to heavy rainfall in the urban areas of Yogyakarta. Scope of this agreement include: Management of drainage infrastructure in the urban areas of Yogyakarta, infrastructure management and drainage facilities on roads Sleman - Yogyakarta City; Yogyakarta - Bantul and Sleman - Bantul regency, Planning and Program Development, Implementation, Supervision includes socialization and control of environmental impact management, Funding and Monitoring and Evaluation.

3. The road sector, road management cooperation agreement aims to synchronize infrastructure management and urban roads in Yogyakarta. Scope of the Agreement include: Management of the mesh infrastructure in urban areas of Yogyakarta, covering an area of Bantul, Yogyakarta City Region and Region Sleman regency, which cooperated Roads are roads that become District / town authority is located in the border areas between the District / city, road infrastructure and facilities in this agreement include roads Bantul - Sleman; Yogyakarta - Yogyakarta and Sleman - Bantul, Programming and Planning, Execution, Monitoring and controlling includes socialization, roads licence dispensation, management environmental impact, Monitoring Financing and Evaluation.

4. Wastewater Sector, Cooperative management of wastewater infrastructure is create on the basis of mutual help in the operation and maintenance of WWTP, main pipeline along the 10 kilometers in order for the use, management and development of wastewater treatment can be carried out effectively and efficiently and meet the technical standards environment. Wastewater management scope includes: Utilization with mains pipelines and wastewater treatment as wastewater treatment household and non-household, operational management and maintenance of main pipelines and wastewater treatment facilities based on the principles of corporate management (OM), infrastructure development, establishment organization and working procedures, determination and revenue personnel, financing, tariff setting, environmental management, management development cooperation with taps and private parties.

5. Waste Sector, Co-operation of waste management facilities and infrastructure intended for the management and utilization of facilities and infrastructure in place Piyungan final disposal as waste disposal in urban areas Jogjakarta with Standard

Operating Procedure mutually agreed and control capacity of the environment in a sustainable manner. The scope of the collaboration infrastructure and waste management include: Utilization with landfill waste infrastructure for urban areas of Yogyakarta, operational management and maintenance, infrastructure development, establishment and organization of work procedure, determination of income personnel, Environment and Financing

6. Transport sector, The purpose of the collaboration infrastructure and facilities management is the creation of a synchronization program activities in the urban areas of Yogyakarta. Management of infrastructure and transportation facilities, include: Subsystem management and road freight traffic engineering, transportation management subsystem of people, goods transportation subsystem, management subsystem node / terminal road transport, road transport network subsystem urban rail and Subsystems coaching, counseling and monitoring the impact of management environment. Scope of the Agreement include: Management of infrastructure and transportation systems in urban areas of Yogyakarta, covering an area of Bantul, Yogyakarta City Region and Regional District of Sleman and Transportation Management System, includes: Sub System Traffic Management and Road Transportation Engineering, Transportation Management System Sub People, Goods Transport Management System Sub, Sub Node Management System Terminal Road Transport, Road Transport Network Sub System Railway Urban, Sub System Development, Extension and Monitoring Environmental Impact.

## 5. Sharing in Cooperation in Financing Kartamantul

Sharing Financing Facility management infrastructures in Kartamantul are as follows:

1. Waste Sector, Financing Management of operation and maintenance, development and environmental management on landfill waste Piyungan Sewon as proportionally based on the volume of waste disposed of to landfill. Share calculation is based on the amount of financing waste transported tonnage starting in October the previous year to September of the current year. Waste volume was used as the basis for calculating sharing financing district / city in the period of 1 year to come. Sharing / financial contribution calculated with the following formula:

$$A = P \times B$$

Description: A = Magnitude sharing / contribution budget

P = Percentage Volume of Waste  
B = Budget operational and maintenance expenses

2. Wastewater Sector, Financing Management WWTP operation and maintenance in Sewon borne proportionately shared by number of household connections and non-household based on a total number of connections are taken into account in the previous year.

3. Transport Sector, Infrastructure and Facilities Management Financing Transportation Systems, shelter management is the responsibility of the parties, while the management of infrastructure and transportation facilities in the area of cross-financed by the Provincial Government of Yogyakarta, Central Government and donor organizations.

4. Road Sector, Financing the operation and maintenance of border roads managed by the parties and or exploit the dominant,

5. drainage sector, Finance Management and development of drainage channels in the border areas that utilize managed by more dominant drainage / longer.

6. Water Sector, Financing Management of operation and maintenance, development of water borne along proportionately based on volume of water consumed by each county / city.

## 6. Conclusion

In the era of regional autonomy where every district of the city has the authority to implement broader development. However, not all socio-economic activities can be carried out by administrative region. Therefore urban cooperation becomes mandatory as part of efforts to improve the quality of public services. Because of inter-regional cooperation can be an effective method to overcome the limitations of the public sector, especially in the aspects of HR and Budget

As stated in the Law. 32/2004, the nature of the development of inter-regional cooperation is an effort to build and improve the excellent service to the community. And the practice of urban cooperation undertaken by DIY can prove that the cooperation between the regions in the provision of infrastructure to improve the performance of services in these areas, which in turn increases the welfare of the community.

## References

- (1). Tarigan Antonius. Kerjasama Antar Daerah (KAD) Untuk Peningkatan Penyelenggaraan Pelayanan Publik Dan Daya Saing Wilayah , *Buletin Tata Ruang, Maret-April 2009 (Edition: Meningkatkan Daya Saing Wilayah)*
- (2) TjahjanulinDomai. Interregional Cooperation Policy In Sound Governance Perspective, *Advances in Natural and Applied Sciences, Brawijaya Univercity. 2011. 5(3): 235-241, ISSN 1995-0772*
- (3) Utomo Tri Widodo W, *Prospek Pengembangan Kerjasama Antar Daerah Kabupaten/Kota Di Kalimantan Timur Dalam Penyelenggaraan Urusan Pembangunan Dan Pelayanan Masyarakat, Baliumbang East Kalimantan. 2005.*
- (4) The Act of Indonesian Republic Number 32 in 2004 (Revised of The Act No. 22 in 1999) on Autonomy Era
- (5) The Home Affairs Ministry Regulation Number 69 in 2007 on Urban Development cooperatin
- (6) Government Regulation Number 38 in 2007 on Mandatory Affair of Local Government
- (7) Government Regulation Number 50 in 2007 on The Implementation Procedures for Regional Cooperation
- (8) The Agreement of Interregional Cooperation of Yogyakarta, Sleman & Bantul On The Management of Infrastructure facilities & road Transportation System Number 05/PK/2001; 08/PK.KDH/A/2001; 10/Perj/BT/2001
- (9) The Agreement of Interregional Cooperation of Yogyakarta, Sleman & Bantul On Landfill Waste at Piyungan - Bantul Number 02/PK/2001; 05/PK.KDH/2001; 07/Perj/BT/2001
- (10) The Agreement of Interregional Cooperation of Yogyakarta, Sleman & Bantul On The Management of Management of Waste Water Processing Installation at Sewon - Bantul Number 03/PK/2001; 06/PK.KDH/2001
- (11) The Agreement of Interregional Cooperation of Yogyakarta, Sleman & Bantul On The Road Infrastructure in Urban Area of Yogyakarta Number 10/PK/2003; 17/PK.KDH/A/2003
- (12) The Agreement of Interregional Cooperation of Yogyakarta, Sleman & Bantul On Management of Clean Water Number 04/PK/2001; 07/PK.KDH/2001; 08/Perj/BT/2001
- (13) The Annual Report Of Kartamantul on 2010 & 2011

## Testing $\alpha$ - and $\beta$ - Convergence of Regional House Prices in China

Fang Zhang, John Hudson, Bruce Morley  
Department of Economics, University of Bath  
[f.zhang@bath.ac.uk](mailto:f.zhang@bath.ac.uk), [j.r.hudson@bath.ac.uk](mailto:j.r.hudson@bath.ac.uk), [b.morley@bath.ac.uk](mailto:b.morley@bath.ac.uk)

### Abstract

*This paper investigates  $\alpha$ - and  $\beta$ - convergence of regional house prices in China over 1998 to 2010. Existing studies about Chinese regional house prices are very limited and have failed to reach a convincing consensus on whether or not regional house prices exhibit convergence with each other. This paper develops two innovative approaches to quantitatively examine the convergence of house prices within cities. In this paper, 35 main capital cities' house price indexes (1998Q1-2010Q4) are selected and applied into recent commonly considered  $\sigma$ -convergence and  $\beta$ -convergence analysis. One of this paper's originalities is the first time to apply above approaches into the study of regional house prices in China. Generally, both empirical results suggest that there is no evidence of convergence between these cities; but with the sub-sample of variation starting from 2004, there is a strong evidence of  $\beta$ -convergence between regional house prices.*

### 1. Introduction

As we know, China has become one of the fastest developing countries in the world. Even during the Asian and Global Financial Crisis, the Chinese economy has still maintained a very high-speed of growth. The housing market relates to a significant industry for the whole economic system and has always been a barometer of the economy. Since the welfare housing system has been gradually phased out in 1990s, the Chinese housing market has been through a rapid development over last two decades. During global financial crisis periods, most of countries' housing markets have been through an unprecedented rough time; while the Chinese housing market has sustained growth rather than a depression.

The Chinese housing market most likely exhibits some distinct characteristics from other fully market-oriented housing markets in the developed countries,

such as the UK. According to the existing literature, there is some evidence of convergence between regional house prices in the UK. In order to test whether the Chinese housing market has the similar feature or not, this paper is going to apply  $\alpha$ -convergence and  $\beta$ -convergence approaches, which have not been used on Chinese regional house prices as yet, to investigate the convergence of regional house prices in China. This paper will use a wide range of House Price Indexes for 35 cities—30 capital cities (*sheng hui cheng shi*) and 5 municipalities with independent planning status (*ji hua dan lie shi*)<sup>25</sup>—from 1998Q1 to 2010Q4.

With the worldwide real estate boom in the 1990s, an extensive literature has comprehensively analysed the properties and behaviour of regional house prices by principally focusing on testing the convergence or ripple effects of regional house prices in a certain economy, initially starting from the UK (Holmans [1]; Gussani and Hadjimatheou [2]; MacDonald and Taylor [3]; Alexander and Barrow [4]; Drake [5]; Ashworth and Parker [6]; Mean [7]; Cook [8]; Cook and Thomas [9]; Holmes [10]; Holmes and Grimes [11]; Cook [12]) and more recently for the USA (Gallet [13]; Clark and Coggin [14]; Holmes, Otero, and Panagiotidis [15]; Kim and Rous [16]) and Taiwan (Chien [17]; Lee and Chien [18]; Chen, Chien and Lee [19]).

---

<sup>25</sup> Five municipalities with independent planning status are Dalian, Qingdao, Ningbo, Xiamen and Shenzhen approved by The State Council of China on 18th July 1984, 15th October 1986, 24th February 1987, 18th April 1988 and 3rd October 1988 respectively. The municipalities with independent planning status are big cities with more than 15 billion yuan gross social output value and more than 1 million population. With the strong industrial and commercial foundation and advanced science and technology, they play a significant role in the economic development of China. They are independent accounts in the state planning like other capital cities; under the direct instructions from the State, they have the decision-making power and economic management power at the provincial level.



Most of these existing researches focus on the univariate/panel ADF unit root test and other derivative unit root tests as well, such as SURADF unit root test and the two-break LM unit root test *etc* (Cook [8]; Gallet [13]; Holmes [10]; Holmes and Grimes [11]; Clark and Coggin [14]; Chien [17]; Lee and Chien[18]). The alternative approaches applied to convergence analysis include Granger causality tests (Holmans [1]; Gussani and Hadjimatheou [2]; MacDonald and Taylor [3]; Alexander and Barrow [4]), the time varying parameter (TVP) estimation (Drake [5]), Friedman's non-parametric test (Cook and Thomas [9]), log t convergence (Kim and Rous [16]), and a pair-wise approach (Holmes *et al* [15]). Specially, Cook [12] proposed  $\alpha$ -convergence and  $\beta$ -convergence tests to examine the regional house prices of UK. His findings of  $\alpha$ -convergence fail to detect convergence, probably as a result of its episodic nature. However, there is  $\beta$ -convergence not only over the full sample of observations available, but over cyclical sub-samples as well.

House prices in China's metropolitan areas have recently exhibited rapid growth, which has also raised the attention of both researchers' and policy-makers' interest and encouraged investigation into the behaviour of regional house prices. However, there is only a limited literature on testing China's regional house price convergence or ripple effects (Liu and Zhang [20]; Zhang and Liu [21]).

In 2008, Liu and Zhang [20] applied a qualitative model—the Regional Economy Three-sector Equilibrium Model<sup>26</sup> proposed by Dipasquale and Wheaton [22]—to examine house price ripple effects within cities. Afterwards, based on quantitative econometric principles, Zhang and Liu [21] select eight main capital cities' house price indexes (Beijing, Chengdu, Harbin, Hangzhou, Nanjing, Shanghai, Shenzhen and Xi'an) from the second quarter of 1998 to the fourth quarter of 2007, and then investigate the ripple effects of house prices between cities by using the univariate unit root test, the Engle-Granger test and the error correction model. Their findings reveal that there are ripple effects between eight cities' house price indices; simultaneously, the significant evidence shows that Shenzhen is the original region of nationwide house price rising and Beijing and Shanghai are the secondary ones.

Apart from Zhang and Liu's work, there is little available literature on the convergence of Chinese

regional house prices. Even though these authors achieved some results on the regional house prices in China, the limited data set for both the geographical dimension and the time dimension make their conclusions somewhat unconvincing. China is a large country with many different geographical areas, while there are only 8 cities that they selected; and their time period across 1998 to 2007 only covers the effects of the 1997 Asian Financial Crisis excluding the more influential global financial crisis of 2008. Another major limitation of their work is that the house price index they used is a link index<sup>27</sup> based on the same quarter of last year. This kind of link index is not sufficient for econometric estimations. In order to generate more persuasive findings, in our estimation the link index of house prices will be transformed into a new continual index.

This paper contains five sections: Section I include introduction and literature review; Section II explains the methodology we will use; Section III describes the data and the process of data transformation; Section IV illustrates the empirical findings of  $\alpha$ - and  $\beta$ -convergence estimations; and Section V is conclusion.

## 2. Methodology

The use of unit root tests is referred to as a means of examining stochastic convergence, with movement towards underlying equilibria considered. The alternative common forms of convergence in the economic growth literature are referred to as  $\sigma$ -convergence and  $\beta$ -convergence. Cook [12] describes these two notions as:

*“The first of these notions,  $\sigma$ -convergence, refers to the narrowing of the spread of the cross-sectional distribution of a group of series over time. In the context of the analysis of regional house prices, this necessitates calculation of the coefficient of variation across regions for each time-period, prior to examining changes in this coefficient through time. If the coefficient decreases through time, the spread can be seen to narrow and hence convergence can be deemed to have occurred. The second form of convergence,  $\beta$ -convergence, refers to the notion of series with lower (higher) initial values experiencing faster (slower) growth than series with higher (lower) initial values. Hence,  $\beta$ -convergence refers to a*

<sup>26</sup> In their model, a regional economy consists of three parts: regional product market (including product and service), regional labour market and regional housing market. These three markets in the same city are interrelated and interact with each other.

<sup>27</sup> Link index is based on the same quarter of last year; for example, if the index of 1998Q1=100, 1998Q2=100, 1998Q3=100, and 1998Q4=100; then the index of 1999Q1 is based on 1998Q1, 1999Q2 is based on 1998Q2, 1999Q3 is based on 1998Q3, and 1999Q4 is based on 1998Q4.

*drawing-together of differing series via the initial gaps between them closing. If lower (higher) initial values do lead to higher (lower) growth as required under  $\beta$ -convergence, the coefficient on the initial level term will be negative. Hence, subsequent testing for the presence of  $\beta$ -convergence is based upon this coefficient being significantly negative.”*

## 2.1. $\alpha$ -convergence

The studies of  $\sigma$ -convergence have been developed by Friedman [23] and Quah [24] to test the convergence of some macroeconomic variables, GDP and income across countries. Cook [12] applies  $\sigma$ -convergence as one of the comparable methodologies to analysis the convergence of UK house prices. As they suggest, the existence of  $\sigma$ -convergence is implied by the decline of the coefficient of variation.

To the  $\sigma$ -convergence test for China's house price indexes, the coefficient of variation is calculated across all regions/cities for each quarter, with its movements chronicled. The coefficient of variation of regional house price indexes ( $CV_t$ ) is  $CV_t = S.D_t / \bar{X}_t$ , where  $S.D_t$  and  $\bar{X}_t$  are the standard deviation and the average value of regional house price indexes respectively at time  $t$ . Therefore, if the value of is decreasing, there will be evidence of  $\sigma$ -convergence between regional house prices in China.

## 2.2. $\beta$ -convergence

To compare with  $\alpha$ -convergence, an alternative form is considered, which is  $\beta$ -convergence promoted by Drennan and Lobo [25] and Cook [12]. In the early 1990s, Sala-i-Martin [26] discusses the income convergence in the USA and illustrates the difference between  $\sigma$ -convergence and  $\beta$ -convergence: the former indicates how the distribution of income evolves over time and the latter shows the mobility of income within the same distribution. Afterwards, Arbia, Basile and Piras [27] develop two kinds of  $\beta$ -convergence—the cross-section  $\beta$ -convergence and the panel  $\beta$ -convergence—to analyse regional growth behaviour in Italy. Recently, Cook [12] has applied the  $\beta$ -convergence test with UK regional house prices.

As they argue,  $\beta$ -convergence aims to use a regression equation in which the growth rate is regressed against the initial level. In the cross-section version, the house price growth rate for each city needs to be identified firstly in the following way:

$$GHPI = (HPI_N - HPI_1) / HPI_1 * 100 \quad (1)$$

Where  $GHPI$  is the growth rate,  $HPI_N$  is the house price index in the last period, and  $HPI_1$  is the house price in the first period. After obtaining the growth rates for all the regions, the cross-section regression is run between the growth rate and the house price index in the first time period:

$$G_i = \alpha + \beta HPI_{i,1} + \varepsilon \quad (2)$$

Where  $G_i$  is the growth rate for region  $i$ ,  $HPI_{i,1}$  is the house price index of region  $i$  in the first time period, and  $\varepsilon$  is the error term.

One of the major advantages of the panel data approach to convergence is that it can be helpful for the correction of the bias generated by omitted variables and heterogeneity in the classical cross-sectional regression (Islam [28]). Panel data, in fact, allows for technological differences across regions (or at least the unobservable and unmeasurable part of these differences) by modelling the regional specific effect (Arbia *et al* [27]). More formally, the panel version of the growth equation can be expressed as:

$$GHPI_{i,t} = \alpha + \beta HPI_{i,t-1} + \varepsilon \quad (3)$$

Where  $GHPI_{i,t}$  is the growth rate of HPI (House Price Index) for region  $i$  in the time period  $t$ ;  $GHPI_{i,t-1}$  is HPI for region  $i$  in the previous time period  $t-1$ ; and  $\varepsilon$  is the error term.

Hereby, for both  $\beta$ -convergence models, if the coefficient  $\beta$  is negative and significant, we can say there is  $\beta$ -convergence between regional house prices in China, and the house prices in cities with lower house prices grow faster than in cities with higher house prices.

To speak of panel  $\beta$ -convergence, recent research has drawn attention to the issue of cyclicity in the housing market. A salient extension of the analysis of convergence is then based upon the recognition of the potential importance of cyclical factors and the examination of sub-samples based upon cyclical movements (Cook [12]). To explore the possibility of convergence in regional house prices over cyclical sub-samples, Cook and Thomas [9] employ London as the region with which to determine cyclical peaks and troughs to identify the turning-points with the techniques of Birchenhall *et al.* [29].<sup>28</sup> The sub-sample

<sup>28</sup> Cook and Thomas (2003) identify peaks as periods with values: greater than or equal to values observed in the previous two years; strictly greater than values in the following six months; and, greater than or equal to values observed between six months and two years

convergence consideration can be employed into our investigation as well, if there is such a cyclical movement of regional house prices in China.

### 3. Data Description and Transformation

#### 3.1. Data description

All the literature mentioned above on regional house price convergence adopt the quarterly date across different regions. Therefore, this paper will use the house price link index (HPI) (the same quarter of last year=100) for 35 cities from 1998Q1 to 2010Q4, wherein 35 cities include 30 capital cities and 5 municipalities (Dalian, Qingdao, Ningbo, Xiamen and Shenzhen) with independent planning status (Appendix A: Table 1). Each city will be indicated by the city code (1, 2, ..., 35). The link index of HPI data comes from the official database of the National Bureau of Statistics of China (NBSC, www.stats.gov.cn).

Figure 1 plots the link index of house prices for each city. These are link indices and more actually reflect house price changes over a year than a house price index per quarter. Some basic characteristics of regional house prices can be described from the figure. From the overall trend, it indicates several significant peaks for the link index of HPis: the first peak stage appeared between 2002 and 2004, which is most likely affected by the implementation of a new land policy in 2002—the ‘Bidding Auction Listing Transferring State-owned Land Use Rights Provision’; then, China’s house prices experienced the second boom period in 2007; but under the impact of the global financial crisis, the house prices sharply dropped in 2008 and fell to the bottom in 2009. Lately, in 2010, China’s economy then started to recover from the financial crisis and the HPis have returned to growth.

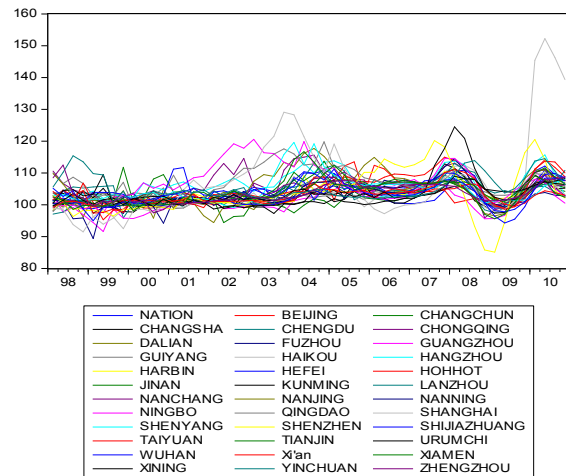


Figure 1. The link index of HPI of 35 cities from 1998Q1 to 2010Q4

We can also see that the link HPis in most cities range between 90 and 120 over the time period, except for Shanghai, Urumchi, Haikou and Shenzhen. The HPis have risen to extraordinary peak values—129.1 for Shanghai in 2003Q4, 124.5 for Urumchi in 2008Q1, and 152.2 for Haikou in 2010Q2. Furthermore, Shenzhen’s HPI fell to the minimum value of 85.1 during the global financial crisis in 2009Q1. These cities’ extreme price indexes exactly reflect the above prosperity and depression stages in China. But, the link index (the same quarter of last year=100) cannot be used for our econometrical methods, as we need an index where all of the values are related to some base quarter when the index was 100; so in order to investigate more precise relationships between China’s regional HPis, we need to replace the link index by such an index (the first quarter=100), which use quarter 1998Q1 as the base period.

#### 3.2. Data transformation

There are several steps to revise the link index data (HPI) into a continuous price index:

(1) The first step is to find the most stable period (covering four quarters) for each city. Based on the original link index of house prices from the NBSC, the most stable four quarters for each city can be identified. The stable periods are stated in Appendix A: Table 2. Firstly, in the four quarters of stability, we make the assumption of annual price change equal to the constant growth of quarterly change (annual rate = (quarterly rate)<sup>4</sup>), which means the link index is adjusted for quarterly rate. The underlying assumption is that if over a sustained period annual house price

ahead. Conversely, troughs are defined as periods with values (i) less than or equal to values observed in the previous two years, (ii) strictly less than values in the following six months and (iii) less than or equal to values observed between six months and two years ahead.

change is  $x$ , then the increase in any one quarter is proportional to  $x$ .

Then, if we say these quarters are ' $\tau+1$ ,  $\tau+2$ ,  $\tau+3$ , and  $\tau+4$ ' ( $\tau=1,2, \dots, 52$ , from 1998Q1 to 2010Q4), the calculation can be started from quarter  $\tau+1$  by setting up the previous index equal to 100 ( $P_{\tau}=100$ ). So we get the adjusted index (P) for the stable quarters:

$$\begin{aligned} P_{\tau+1} &= P_{\tau} * (HPI_{\tau+1} / 100)^{0.25} \\ P_{\tau+2} &= P_{\tau+1} * (HPI_{\tau+2} / 100)^{0.25} \\ P_{\tau+3} &= P_{\tau+2} * (HPI_{\tau+3} / 100)^{0.25} \\ P_{\tau+4} &= P_{\tau+3} * (HPI_{\tau+4} / 100)^{0.25} \end{aligned} \quad (4)$$

After this, the forward calculations are as follows:

$$\begin{aligned} P_{\tau+5} &= P_{\tau+4} * (HPI_{\tau+5} / 100) \\ P_{\tau+6} &= P_{\tau+5} * (HPI_{\tau+6} / 100) \\ &\vdots \\ P_{51} &= P_{47} * (HPI_{51} / 100) \\ P_{52} &= P_{48} * (HPI_{52} / 100) \end{aligned} \quad (5)$$

Remember HPI is an index if house price increased by 10% over the previous 12 months, HPI=110. And the backward calculation is as follows:

$$\begin{aligned} P_{\tau-1} &= P_{\tau+3} * (100 / HPI_{\tau+3}) \\ P_{\tau-2} &= P_{\tau+2} * (100 / HPI_{\tau+2}) \\ &\vdots \\ P_2 &= P_6 * (100 / HPI_6) \\ P_1 &= P_5 * (100 / HPI_5) \end{aligned} \quad (6)$$

(2) After getting the adjusted index (P), the purpose of this exercise has been primarily to identify an index for the first four quarters. The following step is to use the first four quarters (1998Q1 to 1998Q4) as the base index to identify the more precise index ( $P^c$ ), saying  $P_1^c = P_1$ ,  $P_2^c = P_2$ ,  $P_3^c = P_3$ , and  $P_4^c = P_4$ . The further index can be driven by:

$$\begin{aligned} P_5^c &= P_1^c * (HPI_5 / 100) \\ P_6^c &= P_2^c * (HPI_6 / 100) \\ P_7^c &= P_3^c * (HPI_7 / 100) \\ &\vdots \\ P_{52}^c &= P_{48}^c * (HPI_{52} / 100) \end{aligned} \quad (7)$$

(3) To make different cities' indices comparable, the final transformed index (HP) is to divide all values by the index value of  $P^c$  in 1998Q1 ( $P_1^c$ ) and then multiply by 100, which will ensure all indices are 100 in 1998Q1:

$$\begin{aligned} HP_1 &= (P_1^c / P_1^c) * 100 = 100 \\ HP_2 &= (P_2^c / P_1^c) * 100 \\ HP_3 &= (P_3^c / P_1^c) * 100 \\ &\vdots \\ HP_{52} &= (P_{52}^c / P_1^c) * 100 \end{aligned} \quad (8)$$

(4) Finally, the data set can be extended backwards to 1997 as well, based on the HPI link index in 1998, which will ensure no valid data has been omitted. The following equations show the generation of the final transformed index (HP) in 1997:

$$\begin{aligned} HP_{97Q1} &= (HP_{98Q1} / HPI_{98Q1}) * 100 \\ HP_{97Q2} &= (HP_{98Q2} / HPI_{98Q2}) * 100 \\ HP_{97Q3} &= (HP_{98Q3} / HPI_{98Q3}) * 100 \\ HP_{97Q4} &= (HP_{98Q4} / HPI_{98Q4}) * 100 \end{aligned} \quad (9)$$

After the above steps, the original link index of HPI has been revised into the constant growth house price index (HP) from 1997Q1 to 2010Q4. It will be recalled that the HPI gap is the difference between the highest HPI and the lowest HPI over a time period, and this is smallest during the stable period for each city. Appendix A: Table 2 lists the HPI gaps during the stable periods. It can be seen from Figure 2 that most cities have a relatively stable period with the link index (HPI) gap smaller than 1, especially for Beijing, Changchun and Tianjin with a 0.2 gap and Harbin, Taiyuan, Xi'an and Xiamen with a 0.3 gap. But some cities have been through a quite volatile period with the HPI gap higher than 1.5, for instance, 1.5 for Haikou and 1.6 for Kunming and Qingdao. As for the emerging coastal tourism cities of Haikou and Qingdao, the overheated tourist economy in certain periods is likely to cause their greater volatility of HPI changes.

The original link index is based on the same quarter of last year; for example, if HPI in the last quarter is 100 and the house price increased by 10% over the last 12 months, HPI in this quarter is 110.

To transfer the link index into the constant growth index (the first period index=100), we made the assumption of annual price change in the stable four-quarter period equal to the constant growth of quarterly

change (annual rate = (quarterly rate)<sup>4</sup>), denoting the link index is adjusted for the quarterly rate.

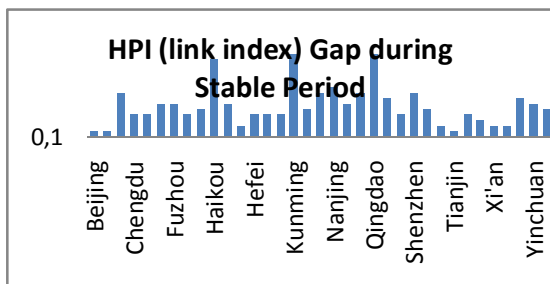


Figure 2. Link index (HPI) gap during stable period

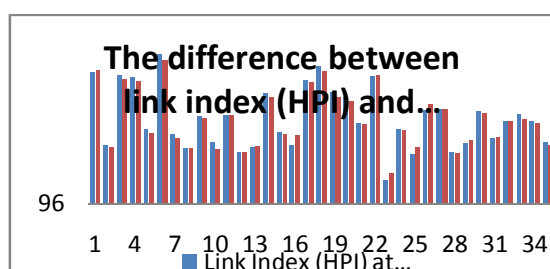


Figure 3. The difference between link index (HPI) and adjusted index (P)

Therefore, in order to estimate the efficiency of our assumption in the first step, Appendix A: Table 2 compares the link index (HPI) with the adjusted index (P) at the last quarter of the stable period. Figure 3 exhibits more straightforwardly the difference by drawing a bi-column chart and shows our estimated index (P) very close to the original index (HPI) for all the cities. The underlying assumption is that if annual house price change is  $x$  over a sustained period, then the increase in any one quarter is proportional to  $x$ . The column graph verifies our assumption is valid and efficient.

After transferring the original link index (HPI) into the constant growth index (HP), we can display the logarithm of new transferred house price indices for each city over 1997Q1 to 2010Q4 in the following Figure 4. It can be seen that, although the intensities of their fluctuations differ from each other, overall there is an upward trend for all the cities, which implies the house prices across China have been through sustained growth over this decade. For instance, Ningbo and Qingdao (the top two lines) have apparently exhibited the most rapid ascending tendency since 2002. More specifically, since then the house price indices of Ningbo and Qingdao have maintained a higher level than the other cities. Because both cities are

municipalities with independent planning status (*ji hua dan lie shi*), the strong motivation of economic development has contributed the fast growth of their house prices. By contrast, Guangzhou (the bottom line) has the lowest growth rate during this period, and its house price index has fluctuated around 4.6 with the lightly upward trend.

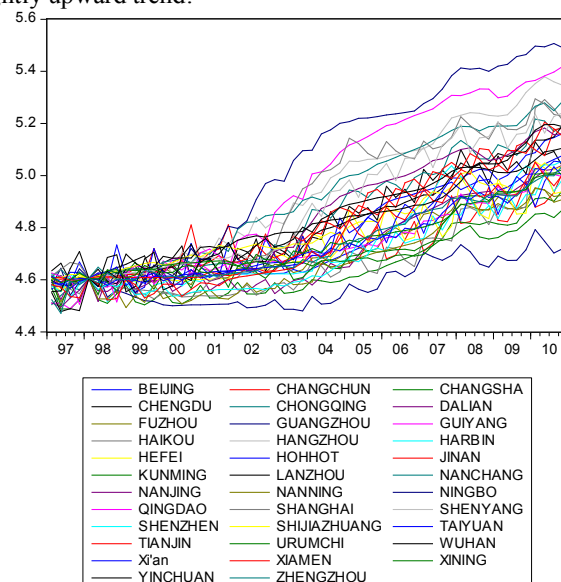


Figure 4. The log of transferred house price (HP) indices

#### 4. Empirical Results

The coefficient of variation ( $CV_t = S.D_t / \bar{X}_t$ ) for the regional house price index of 35 cities, follows the pattern as in Figure 5. As during the data revising process, the index has been set up at 100 in 1998Q1 for all the cities, the CV of zero in 1998Q1 has been dropped from the line graph. From inspection of this figure, it can be seen that CV exhibits a significant upward trend before 2004; afterwards it turns into a relative flat movement with slight fluctuation. The initial period is misleading. Obviously if we constrain all observations to equal 100 in the base quarter, then in succeeding quarters they will more upward, with the coefficient of variation increasing. This will continue until the equilibrium has been reached. The graph suggests this is by the end of 2004, after this date there is no compelling evidence for divergence or convergence.

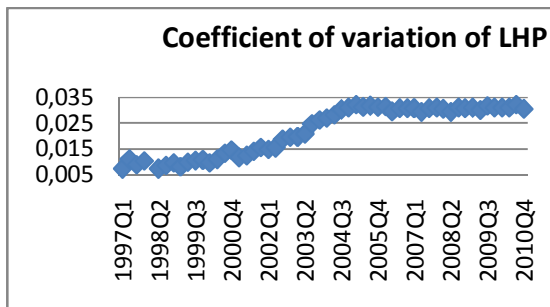


Figure 5: The coefficient of variation of LHP over 1997Q1—2010Q4

While, the  $\sigma$ -convergence shows how the distribution of house prices changes over time; in order to show the mobility of house prices with the same distribution, we apply the  $\beta$ -convergence as the complement of convergence analysis. As mentioned before, following Eq. (1), we get the cross-section  $\beta$ -convergence model is  $GLHP_i = \alpha + \beta LHP_{i,1} + \varepsilon$ , where  $GLHP_i$  is the growth rate for city  $i$  and  $LHP_{i,1}$  is LHP for city  $i$  in the first time period. Additionally, the panel data version of  $\beta$ -convergence model is written as Eq. (2), replace the link index HPI by LHP and get the following equation:  $GLHP_{i,t} = \alpha + \beta LHP_{i,t-1} + \varepsilon$ , where  $GLHP_{i,t}$  is the growth rate of LHP in the current time period and  $LHP_{i,t-1}$  is LHP in the previous time period.

However, since the line graph for  $\sigma$ -convergence (Figure 5) does not reach equilibrium until 2004, the sub-sample convergence consideration can be applied into our panel  $\beta$ -convergence estimation upon the example of Cook (2012). Hereby, the panel  $\beta$ -convergence regression is employed again with the cyclical sub-sample of observations from 2004Q1. Appendix A: Table 3 illustrates the results for both  $\beta$ -convergence models with full sample (1997Q1 to 2010Q4) and sub-sample (2004Q1 to 2010Q4).

It can be seen from above table, for the full sample, the value of both coefficient  $\beta$  are negative; but the t-statistics are 0.415 and 0.635 respectively, which are not significant. Therefore, both results are not significant enough in support of  $\beta$ -convergence between regional house prices for the whole sample of observations. However, the regression of sub-samples exhibits the coefficient  $\beta$  (-0.557) is negative and significant at the 1% level, indicating apparent  $\beta$ -convergence for the sample level since the distribution reached an equilibrium.

## 5. Conclusion

In summary, both  $\alpha$ -convergence and  $\beta$ -convergence fail to support the evidence of convergence of regional house prices in the full sample. However, the panel version of  $\beta$ -convergence estimation detects the existence of convergence for sub-samples that is the convergence between regional house price indices during the period after 2003. The reason we use the period since 2004 is that before that the prices are being heavily influenced by the initial starting point with prices equal to 100 at the beginning of the period. In effect, what we are doing is seeing whether the differences in prices which have built up between 1997 and 2004 are subsequently corrected for. Therefore, regressions based on the period as a whole don't make much sense. Once the distribution had settled down, also in this period there is a strong evidence for either  $\beta$ -convergence or divergence.

## References

- [1] A. E. Holmans, 'House price: changes through time at national and sub-national level', Working Paper 110, Government Economic Service, 1990.
- [2] B. Guisanni, and G. Hadjimathou, 'Modelling regional house prices in the United Kingdom', *Papers in Regional Science*, Vol. 70, No. 2, 1991, pp.201-219.
- [3] R. MacDonald, and M. P. Taylor, 'Regional house prices in Britain: long-run relationship and short-run dynamics', *Scottish Journal of Political Economy*, Vol. 40, No. 1, February 1993, pp. 43-55.
- [4] C. Alexander, and M. Barrow, 'Seasonality and cointegration of regional house prices in the UK', *Urban Studies*, Vol. 31, No. 10, 1994, pp. 1667-1689.
- [5] L. Drake, 'Testing for Convergence between UK Regional House Prices', *Regional Studies*, Vol. 29, No. 4, 1995, pp. 357-366.
- [6] J. Ashworth, and S. Parker, 'Modelling regional house prices in the UK', *Scottish Journal of Political Economy*, Vol. 44, No. 3, August 1997, pp.225-246.
- [7] G. Meen, 'Regional house prices and the ripple effect: a new interpretation', *Housing Studies*, Vol. 14, No. 6, 1999, pp.733-753.
- [8] S. Cook, 'The Convergence of Regional House Price in the UK', *Urban Studies*, Vol. 40, No. 11, October 2003, pp. 2285-2294.



- [9] S. Cook, and C. Thomas, 'An alternative approach to examining the ripple effect in UK house prices', *Applied Economics Letter*, 10, 2003, pp.849-851.
- [10] M. J. Holmes, 'How Convergent are Regional House Prices in the United Kingdom? Some New Evidence from Panel Data Unit Root Testing', *Journal of Economic and social Research*, 9(1), 2007, pp.1-17.
- [11] M. J. Holmes, and A. Grimes, 'Is There Long-run Convergence among Regional House Prices in the UK?', *Urban Studies*, 45 (8), July 2008, pp. 1531-1544.
- [12] S. Cook, 'β-convergence and the Cyclical Dynamics of UK Regional House Prices', *Urban Studies*, 49(1), January 2012, pp. 203-218.
- [13] C. A. Gallet, 'Housing market segmentation: An application of convergence tests to Los Angeles region housing', *The Annals of Regional Science*, Vol. 38, No. 3, September 2004, pp.551-561.
- [14] S. P. Clark, and T. D. Coggin, 'Trends, Cycles and Convergence in U.S. Regional House Prices'. *J Real Estate Finan Econ*, 39 (2009), pp. 264-283.
- [15] M. J. Holmes, J. Otero, and T. Panagiotidis, 'Investigation regional house price convergence in the United States: Evidence from a pair-wise approach'. *Economic Modelling*, Vol. 28, No. 6, 2011, pp. 2369-2376.
- [16] Y. S. Kim, and J. J. Rous, 'House Price Convergence: Evidence from U.S. State and Metropolitan Area Panels', *Journal of Housing Economics*, Vol. 21, No. 2, June 2012, pp. 169-186.
- [17] M. S. Chien, 'Structural Breaks and the Convergence of Regional House Prices'. *J Real Estate Finance Econ*, 40 (2010), pp. 77-88.
- [18] C. C. Lee, and M. S. Chien, 'Empirical Modelling of Regional House Price and the Ripple Effect', *Urban Studies*, 48(10), August 2011, pp. 2029-2047.
- [19] P. F. Chen, M. S. Chien, and C. C. Lee, 'Dynamic modeling of regional house price diffusion in Taiwan', *Journal of Housing Economics*, 20 (2011), pp. 315-332.
- [20] L. H. Liu, and H. J. Zhang, '*Housing Price Ripple Effects Within Cities: A Perspective of Regional Economy Three-sector Equilibrium Model*', 2008 International Seminar on Business and Information Management, Wuhan, December 2008, pp. 496-499.
- [21] H. J. Zhang, and L. H. Liu, '*Empirical Research on Housing Price Ripple Effect between China's Cities*', 2009 International Conference on Service Science, Management and Engineering, Zhangjiajie, July 2009, pp.43-46.
- [22] D. Dipasquale, and C. W. Wheaton, '*Urban economics and real estate markets*', Indiana: Prentice Hall, 1995.
- [23] M. Friedman, 'Do old fallacies ever die?', *Journal of Economic Literature*, Vol. 30, No. 4, December 1992, pp. 2129-2132.
- [24] D. Quah, 'Galton's fallacy and tests of the convergence hypothesis', *Scandinavian Journal of Economics*, 95(4), 1993, pp. 427-443.
- [25] M. Drennan, and J. Lobo, 'A simple test for convergence of metropolitan income in the United States', *Journal of Urban Economics*, Vol. 46, No. 3, 1999, pp. 350-359.
- [26] X. Sala-i-Martin, '*Regional Cohesion: Evidence and Theories of Regional Growth and Convergence*', Discussion Paper No. 1075, Centre for Economic Policy Research, November 1994
- [27] G. Arbia, R. Basile, and G. Piras, '*Using Spatial Panel Data in Modelling Regional Growth and Convergence*', Istituto Di Studi E Analisi Economica, Working paper n. 55, September 2005
- [28] N. Islam, 'What have we learnt from the convergence debate?', *Journal of Economic Surveys*, Vol. 17, No. 3, July 2003, pp. 309-362.
- [29] C. Birchenhall, D. Osborn, and M. Sensier, 'Predicting UK business cycle regimes', *Scottish Journal of Political Economy*, Vol. 48, No. 2, May 2001, pp. 179-195.

## Appendix A

Table 1: Classes and city codes of 35 cities

City Code	Cities	Classes of Cities	City Code	Cities	Classes of Cities
1	Beijing	Beijing	19	Nanjing	Capital city of Jiangsu
2	Changchun	Capital city of Jilin	20	Nanning	Capital city of Guangxi
3	Changsha	Capital city of Hunan	21	Ningbo	Municipality in Zhejiang
4	Chengdu	Capital city of Sichuan	22	Qingdao	Municipality in Shandong
5	Chongqing	Chongqing	23	Shanghai	Shanghai
6	Dalian	Municipality in Liaoning	24	Shenyang	Capital city of Liaoning
7	Fuzhou	Capital city of Fujian	25	Shenzhen	Municipality in Guangdong
8	Guangzhou	Capital city of Guangdong	26	Shijiazhuang	Capital city of Hebei
9	Guiyang	Capital city of Guizhou	27	Taiyuan	Capital city of Shanxi
10	Haikou	Capital city of Hainan	28	Tianjin	Tianjin
11	Hangzhou	Capital city of Zhejiang	29	Urumchi	Capital city of Xinjiang
12	Harbin	Capital city of Heilongjiang	30	Wuhan	Capital city of Hubei
13	Hefei	Capital city of Anhui	31	Xi'an	Capital city of Shaanxi
14	Hohhot	Capital city of Inner Mongolia	32	Xiamen	Municipality in Fujian
15	Jinan	Capital city of Shandong	33	Xining	Capital city of Qinghai
16	Kunming	Capital city of Yunnan	34	Yinchuan	Capital city of Ningxia
17	Lanzhou	Capital city of Gansu	35	Zhengzhou	Capital city of Henan
18	Nanchang	Capital city of Jiangxi	-	-	-

Table 2: The stable period and the index difference after adjustment

City Code	City	Stable Period (cover 4 quarters)	link index (HPI) gap during stable period	link index (HPI) at the last quarter of stable period	adjusted index (P) at the last quarter of stable period	the difference between link index (HPI) and adjusted index (P)
1	Beijing	2004Q4—2005Q3	0.2	106.3	106.4	0.1
2	Changchun	1998Q1—1998Q4	0.2	100.5	100.4	-0.1
3	Changsha	2006Q2—2007Q1	0.9	106	105.674	-0.3256
4	Chengdu	1998Q3—1999Q2	0.5	105.8	105.574	-0.2252
5	Chongqing	2001Q4—2002Q3	0.5	101.8	101.499	-0.3002
6	Dalian	2007Q1—2007Q4	0.7	107.6	107.174	-0.4253
7	Fuzhou	1998Q3—	0.7	101.4	101.149	-0.2505



		1999Q2			5	
8	Guangzhou	2001Q1— 2001Q4	0.5	100.3	8	100.299 -0.0002
9	Guiyang	2004Q3— 2005Q2	0.6	102.8	7	102.699 -0.1003
10	Haikou	2001Q2— 2002Q1	1.5	100.8	4	100.248 -0.5516
11	Hangzhou	2006Q2— 2007Q1	0.7	102.9	7	102.899 -0.0003
12	Harbin	2002Q4— 2003Q3	0.3	100	2	99.9999 -8E-05
13	Hefei	2001Q1— 2001Q4	0.5	100.4	8	100.474 0.0748
14	Hohhot	2007Q1— 2007Q4	0.5	104.6	8	104.349 -0.2502
15	Jinan	1998Q2— 1999Q1	0.5	101.6	8	101.449 -0.1502
16	Kunming	2006Q1— 2006Q4	1.6	100.6		101.322 0.722
17	Lanzhou	2005Q2— 2006Q1	0.6	105.6	8	105.449 -0.1502
18	Nanchang	2006Q3— 2007Q2	0.9	106.7	3	106.324 -0.3757
19	Nanjing	2006Q1— 2006Q4	1.0	104.7	2	104.349 -0.3508
20	Nanning	2006Q2— 2007Q1	0.7	104.3	7	103.949 -0.3503
21	Ningbo	2006Q1— 2006Q4	0.9	102.2	5	102.149 -0.0505
22	Qingdao	2006Q3— 2007Q2	1.6	105.9	5	105.998 0.0985
23	Shanghai	1999Q4— 2000Q3	0.8	97.8	3	98.3744 0.57443
24	Shenyang	1998Q3— 1999Q2	0.5	101.8	8	101.724 -0.0752
25	Shenzhen	2002Q1— 2002Q4	0.9	99.9	5	100.399 0.4995
26	Shijiazhuang	1999Q1— 1999Q4	0.6	103.3	7	103.724 0.4247
27	Taiyuan	2002Q1— 2002Q4	0.3	103.4	9	103.324 -0.0751
28	Tianjin	2000Q1— 2000Q4	0.2	100	6	99.9499 -0.05004
29	Urumchi	2001Q1— 2001Q4	0.5	100.7	7	100.949 0.2497
30	Wuhan	2006Q2— 2007Q1	0.4	103.2	9	103.049 -0.1501
31	Xi'an	2002Q3— 2003Q2	0.3	101.1	9	101.199 0.0999
32	Xiamen	2002Q4— 2003Q3	0.3	102.4	9	102.424 0.0249
33	Xining	2006Q3— 2007Q2	0.8	103	6	102.624 -0.3754
34	Yinchuan	2005Q4— 2006Q3	0.7	102.4	7	102.274 -0.1253
35	Zhengzhou	2001Q1— 2001Q4	0.6	100.8	7	100.574 -0.2253

<b>Nation</b>	2006Q2— 2007Q1	0.4	105.6	9	105.524	-0.0751
---------------	-------------------	-----	-------	---	---------	---------

Table3: Results of both  $\beta$ -convergence models with full sample and sub-sample

Cross-section $\beta$ -convergence model			Panel $\beta$ -convergence model (full sample)			Panel $\beta$ -convergence model (sub-sample)		
Dependent Variable	$GLHP_i$		Dependent Variable	$GLHP_{i,\tau}$		Dependent Variable	$GLHP_{i,\tau}$	
Number of obs	35		Number of obs	1925		Number of obs	980 (from 2004Q1)	
Explanatory Variable	Coefficient	P-value	Explanatory Variable	Coefficient	P-value	Explanatory Variable	Coefficient	P-value
$LHP_{i,1}$	-14.675 (-0.83)	0.415	$LHP_{i,1}$	-0.045 (-0.47)	0.635	$LHP_{i,\tau-1}$	-0.557 (-3.86)	0.000 ***
cons	78.350 (0.96)	0.343	cons	0.410 (0.90)	0.369	cons	3.012 (4.24)	0.000 ***
Note: ( ) denotes the t-statistics of the respective coefficients. *** indicates significance at 1% level, ** indicates significance at 5% level. * indicates significance at 10% level.								

# **Tourism**

# Turkey's Image as a Tourist Destination in Northern Europe

Hasan Ayyildiz<sup>1</sup>,

Associate Professor, Karadeniz Technical University, Trabzon, Turkey  
[ayyildiz@ktu.edu.tr](mailto:ayyildiz@ktu.edu.tr)

Gulcin Bilgin Turna

PhD Candidate, Karadeniz Technical University, Trabzon, Turkey  
& Visiting Researcher, Erasmus University, Rotterdam 3011 XW, The Netherlands  
[gulcinturna@gmail.com](mailto:gulcinturna@gmail.com)

## Abstract

*Many countries in Northern Europe spend their holidays in Southern Europe to enjoy the good weather and tourist attractions. Turkey has been a powerful country which attracts foreign tourists besides its major competitors such as Spain, Greece and Italy which are situated in the same geographic area and offer similar characteristics such as good climate and rich cultural heritage. Since 2008, mentioned Mediterranean countries have been suffering a deep economic crisis whereas Turkey appears as an emerging force with strong government efforts with its growth prospects and opportunities. In this study, questionnaires were conducted in Sweden and the Netherlands in order to understand how they perceive Turkey as a country*

*and tourism destination. Opinions of visitors and non-visitors were compared both using quantitative and qualitative data. Cognitive country image, affective country image and destination beliefs factors were analyzed in order to make contributions to the area of tourism destination image (TDI). The results also reveal that media and word-of-mouth communication are the most important sources of information for Swedish and Dutch people in the perception of Turkey.*

## 1. Introduction

John Hunt (1975) who is credited with being the first to establish the importance of image as an influencer of travel behavior, defined image as 'impressions' or 'the perceptions held by potential visitors about an area'[1]. Early studies of TDI focused on the measurement of tangible attributes to determine their relative importance. In a study of regional images in America, Mayo found scenery, lack of congestion, and climate to be most significant where Anderssen and Colberg found cost, climate,

and scenery to be the most significant attributes of destination image [2]. Crompton (1979) defined destination image as 'the sum of beliefs, ideas, and impressions that a person has of a destination'. He surveyed 617 students from 12 U.S. universities in American universities to assess Mexico's TDI in terms of two dimensions: a descriptive dimension and an importance dimension. The most significant descriptive attributes were cost and climate. However, the attributes rated as being most important were sanitation and safety [3].

Another important study in TDI was by Gunn in 1972. Her three-stage theory of image development involved 'organic', 'induced' and 'modified-induced'. In the first stage, the mental construct of a place is defined as 'organic', derived unintentionally through life's contacts with education, media and people. The next stage, defined as 'induced', represents an image modified by promotional travel information. The last stage, defined as 'modified-induced' represents an image changed by actual travel and personal experience. From this point, visitor experience was recognized as a key influencer [4].

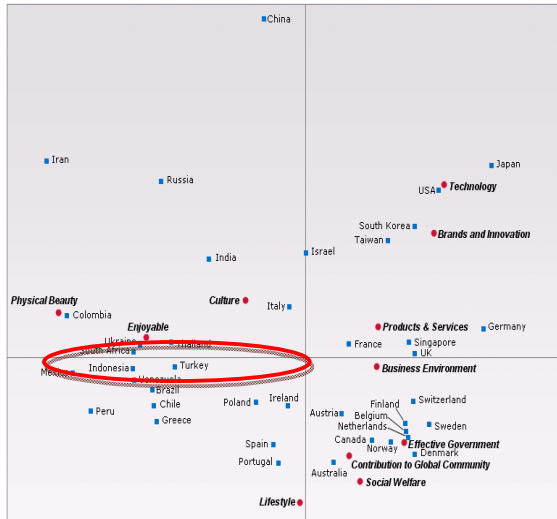
In this paper, questionnaire was conducted with Swedish and Dutch respondents in order to use a conjoint analysis to investigate the importance of cognitive and affective image effects on tourism destination image of Turkish products to travelers in the Netherlands and Sweden. The conjoint analysis approach [5], [6] overcomes the problems associated with single-cue and self-report studies by representing consumer choice as a multi-attribute judgment situation. By investigating its strengths and weaknesses, this study attempts to demonstrate Turkey's image as a tourism destination and show some guidelines how to improve international tourism demand towards Turkey and make contributions to the TDI literature. Being part of the

service industry, tourism requires users to participate both in the production and consumption stages of products and services making the visitors great sources of feedback for destinations. In addition, image perception of a country already occurs before visiting the destination. Therefore, the opinions of visitors and non-visitors were compared both using quantitative and qualitative data.

## 2. Turkey – Popular Tourism Destination

The Reputational Institute’s Country RepTrak™ Pulse provides a standardized metric to assess to what degree Turkey is successful in governing its reputation among the general public in the G8 countries [7]. The study presents the respondents’ particular feelings towards Turkey compared to other countries in terms of their willingness to visit, invest in, work and/or live in the country, and to buy a country’s products. It allows evaluation of the country’s successful reputation performance and the opportunities that arise consequently to attract tourists, investors and employees.

Figure 1: A Multidimensional Map of Countries



Source: Reputation Institute, 2010

Figure 1 maps the perception of respondents, who originate from countries other than the ones under investigation, in regard to the reputation of selected country. It situates Turkey just outside the quadrant involving two attributes: culture and enjoyable.

Turkey’s political and economic liberalization in the 1980s and its bid for full membership of the European Union have made it an attractive destination for European tourists and migrants [8]. Today, Turkey has also become a popular destination for European retirees, particularly for British, German, Dutch and Nordic citizens. Turkey offers what Northern Europeans are in search of: sunshine, a healthy climate, relaxed and outdoor life style, free of formalities and the availability of property for purchase or rental [9].

Table 1 represents world’s top tourism destinations. In 2011, Turkey moved up one position to sixth place (with 29 million tourists) overtaking the United Kingdom.

Table 1: International Tourist Arrivals [10] (million)

	2010	2011
France	77,1	79,5
The USA	59,8	62,3
China	55,7	57,6
Spain	52,7	56,7
Italy	43,6	46,1
<b>Turkey</b>	<b>27,0</b>	<b>29,3</b>
The UK	28,3	29,2
Germany	26,9	28,4
Malaysia	24,6	24,7
Mexico	23,3	23,4

Source: UNWTO Tourism Highlights, 2012, p.6

## 3. Turkey’s Image in Europe

The modern Republic of Turkey finds itself in a turbulent Middle Eastern environment and at a crossroads where there are problems, conflicts and instabilities. However, Turkey has demonstrated success in preserving the attribute of being an island of peace and stability in such a region. Turkey is one

of the rare democracies located in vast geography extending from Europe to the Pacific Ocean and to the Middle East. Turkey has a special place within the Atlantic-European and Eurasian zones. It is in the position of aiming at integration with the western society, in addition to being a democratic, secular and contemporary country of the Islamic world [11].

Strong forces such as globalization, individualization, information and communication technologies impact territorial actors, including countries, regions and cities. The impact of propensity of 'global interconnectedness', particularly of economic, social and political activities are increasingly 'stretched' across globe. The global nature of the current financial and economic turbulences, result in imbalances in the global system, which trigger feelings of uncertainty [12]. On the other hand, Turkish economy has been undergoing a substantial transformation since 2001. Macroeconomic stability produced major drop in interest and inflation, while increased productivity rates enabled the Turkish economy to maintain an average annual growth rate of 5.9%, which is considerably above the historical average, during the 2002-2008 period [13].

Together with Singapore, India and Chile, Turkey achieved rapid economic growth during the last decade, and showed a significant resilience during the economic crisis in 2008. Economic growth and political stability over the past decade have transformed Turkey into an important commercial centre making it more attractive, competitive, and fast growing market for companies from all over the world. A sound macroeconomic strategy in combination with prudent fiscal policies and major structural reforms in effect since 2002 has integrated the Turkish economy into the globalized world, while transforming the country into one of the major recipients of foreign direct investment in its region [14].

#### **4. Turkey's Relations with the Netherlands and Sweden**

Until 1961, more people left the Netherlands than people who moved into the country. It began to face a labor shortage by the mid 1950s, which became more serious during the early 1960s, as the country experienced economic growth rates comparable to the rest of Europe. At the time, Turkey had a problem of unemployment, low GNP levels and high population rates. So the import of labor solved problems on both ends

[15]. The first Turkish immigrants arrived in the Netherlands in the beginning of the 1960s at a time were the Dutch economy was wrestling with a shortage of workers [16]. On 19 August 1964, the Dutch government entered into a 'recruitment agreement' with Turkey. Thereafter, the number of Turkish workers in the Netherlands increased rapidly [17]. Based on the commemoration of Turkey-The Netherlands 400 years of trade, both countries enjoy good political relations and share a desire to strengthen their ties.

Majority of Turkish immigrants living in Germany and the Netherlands do not come from Turkey's more modern cities and regions but from the backward south east. Like many immigrants around the world, they tend to stick with the traditions and values they brought with them years, often decades, ago. While much of Turkey is becoming more open, modern and diverse, many Turkish emigrants remain traditionalist. Germans tend to be concerned about the impact that Turkish accession would have on the EU's balance of power, whereas the Dutch seem less concerned about the supposed contradiction between deepening and widening the EU. And although the Netherlands also hosts a sizeable Turkish immigrant community, public opinion is somewhat more nuanced. But then again, when asked directly, the best thing Dutch people had to say about Turks was that they were not as bad as other Muslim immigrants. The image that the German and Dutch people have of Turkey, although usually grounded in some reality may not necessarily be accurate. Politicians, journalists, bankers and other professionals whose job it is to know about the world frequently update their images of different places. But the general public does not. Perceptions and prejudices, once formed, are useful for navigating an extremely complex world. People will not give them up easily, unless they have a good reason to do so. Therefore, people's images of other places are so often out of date. Turkey's enormous improvements over recent decades, and in particular since 2001, do not register with most Europeans [18].

The relations between Turkey and Sweden are progressing in a very positive manner. Sweden, which is pursuing an active foreign policy in regional and international issues, substantively contributes to the EU foreign policy. Within this framework, Sweden is one of the leading countries that strongly support Turkey's EU membership. The number of Swedish tourists visiting Turkey exceeded 617 thousand in 2012. Approximately 115,000 emigrants

from Turkey live in Sweden, half of whom also have Swedish citizenship [19].

## 5. Study Design

In this study, cognitive image constructs (quality of life, wealth, technology level, education) were adapted from Orbaiz ve Papadopoulos [20] and affective image constructs from Beerli and Martin [21] (pleasant), Echtner and Ritchie [22] (safety), Heslop and Papadopoulos [23] (trustworthy), Orbaiz and Papadopoulos [20] (friendly). Destination beliefs constructs were adapted from Elliot [24] (appealing scenery, suitable accommodation, quality attractions, lots to see and do, value for money, good overall destination).

Table 2 represents the respondents of the questionnaire concerning questions about Turkey's tourism destination image. The target population for this study consisted of university students aged between 18-30 in the Netherlands and Sweden. In addition, their information sources about Turkey and the things come to their minds when they think of Turkey's destinations. Major purpose of this study is to compare differences between visitors and non-visitors of Turkey and make some suggestions to the tourism authorities to strengthen tourism image of Turkey.

Respondents were 363 Dutch university students studying either tourism or marketing and some young faculty members selected from Has Den Bosch University (67) and Rotterdam Erasmus University (296). Most of them are between 20-24 year old university students who have income between EUR 30.001-50.000. Despite being young, they have traveled frequently. With the help of their major of study and travel experience abroad make them knowledgeable about other countries. The items on the questionnaire were measured using a 5-point Likert type scale, ranging from "completely disagree" to "completely agree." Mentioned universities were visited for two weeks. Appointments were taken from the faculty members in order to conduct the questionnaire before or after class. With the support of the teachers, questionnaire was filled studiously in English.

Table 2: Demographic Profile of Respondents (%)

Evaluation	Variable	Sweden (n=311)	The NL (n=363)
Gender	Male	30.23	55.65

	Female	69.77	44.35
Marital Status	Married	10.61	3.03
	Single	57.23	69.70
	Living together	31.51	26.72
	Divorced	0.64	0.55
Number of children	0	88.75	97.24
	1	5.47	1.10
	2	5.78	1.66
Occupation	Student	83.28	84.02
	Teacher	16.72	15.98
Age	Less than 20	29.58	26.45
	20-24	39.55	55.65
	25-29	15.11	13.22
	30-34	7.72	3.58
	35-39	8.04	1.10
Education level	University Student	83.28	84.02
	University Graduate	16.72	15.98
Annual income of the household	10.00 € and less	14.47	12.67
	10.00 €-20.000 €	18.33	8.54
	20.00 €-30.000 €	17.36	10.19
	30.00 €-50.000 €	21.22	26.72
	50.00 €-75.000 €	14.47	19.28
	75.00 €-100.000 €	9.00	9.37
	100.001 €-150.000 €	2.57	7.72
	150.001 € and more	2.57	5.51
Trips	0 trip	5.47	2.20

to other countries	1 trip	7.07	2.74
	2 trips	15.4	5.51
	3 trips	13.8	9.63
	4 trips	9.97	8.82
	5 and more trips	48.2	71.10
Visited Turkey	Yes	37.9	39.90
	No	62.1	60.10

## 6. Findings

Table 3: Mean Scores of the Variables – Sweden (5-Point Likert Scale)

Cognitive Image of Turkey	Swedish Respondents (N=311)		
	Visitors (N=118)	Nonvisitors (N=193)	Average
1. Quality of life	2,66	2,79	2,73
2. Good economy	2,81	2,95	2,88
3. Rich people	2,64	2,72	2,68
4. Technology level	2,66	2,77	2,72
5. Good education	2,91	2,80	2,86
6. Modern country	2,77	2,89	2,83
Average	2,74	2,82	2,78
<b>Affective Image of Turkey</b>			
1. Friendly people	3,63	3,51	3,57
2. Safe country	3,10	3,05	3,08
3. Trustworthy people	2,98	3,11	3,05
4. Pleasant people	3,60	3,42	3,51
5. Ideal to live	2,59	2,58	2,59
6. Ideal to visit	3,86	3,58	3,72
Average	3,29	3,21	3,25
<b>Destination Beliefs of Turkey</b>			
1. Good scenery	4,02	3,77	3,90
2. Suitable accommodation	3,15	3,06	3,11
3. High quality attractions	3,59	3,58	3,59
4. Lots to do and see	3,94	3,70	3,82
5. Good value for the money	4,03	3,73	3,88

6. Good tourism destination	4,18	3,99	4,09
Average	3,82	3,64	3,73

Wilcoxon T test (  $p > 0,05$  )

### 6.1. Cognitive Image of Turkey

Cognitive evaluation refers to beliefs and knowledge about an object, in this case, Turkey. Surprisingly, Swedish respondents who visited Turkey scored less than the ones who have not visited Turkey. That means they had higher expectations before visiting. Dutch respondents who visited Turkey on the other hand, who had probably lower expectations before visiting, scored higher than non-visitors. On a 5-point scale, when both Dutch and Swedish respondents' scores are evaluated, the average is 2,83 (non-visitors average is 2,81 and visitors average is 2,85) which is quite low meaning Turkey should focus on improving its cognitive variables. The cognitive view of a foreign person about a country cannot be changed by visitor experience, rather by overall governmental efforts such as improving the education system, economy and technology level in the country.

### 6.2. Affective Image of Turkey

Cognitive evaluation refers to beliefs and knowledge about an object whereas affective evaluation refers to feelings about the object [25], [26], [27], [28]. In other words, cognitive element of destination image describes the beliefs and information that people have about a place. Affective element describes what people feel about a place; it is about loving or not loving somewhere [29]. Social and environmental psychological tradition regards cognition and affect as interrelated elements, where affect is largely dependent on cognition. However, Russell and Snodgrass [30] argued that behavior may be influenced by the (estimated, perceived, or remembered) affective quality of an environment rather than by its objective properties directly. The affective component of destination image expresses feelings toward a destination, which can be favorable, unfavorable, or neutral [31]. Gartner [25] suggested that the affective component comes into play at the stage when different travel alternatives are evaluated. Many studies revealed that affective country image has more effect on destination beliefs than cognitive country image [24], [32]. In terms of affective image, it is seen from the tables 3 and 4 that visitors rated



higher than non-visitors. It can be concluded that when people visit Turkey, they tend to develop more positive affective image.

### 6.3 Destination Beliefs of Turkey

Experience of a tourist is considered to be highly emotional value and of personal significance to every individual and relates to significant experience value as against tangible products [33], [34]. It is evident that destination image of a country influences the choice in decision making process of a tourist [35], [36], [37], [38], [39], [40], [41]. A location with a strong and positive brand image is more likely to be chosen by a tourist as a location to travel [42], [43].

Respondents who have visited Turkey have more positive attitude toward Turkey's tourism potential. Dutch seem to be more positive, probably because they had low expectations before visiting or they are exposed to many Turkish immigrants in their country so they developed familiarity and sympathy.

Table 4: Mean Scores of the Variables – The Netherlands (5-Point Likert Scale)

Cognitive Image of Turkey	Dutch Respondents (N=363)		
	Visitors (N=145)	Nonvisitors (N=218)	Average
1. Quality of life	3,01	2,83	2,92
2. Good economy	3,13	2,97	3,05
3. Rich people	2,64	2,58	2,61
4. Technology level	3,03	2,79	2,91
5. Good education	2,98	2,81	2,90
6. Modern country	2,91	2,74	2,83
Average	2,95	2,79	2,87
<b>Affective Image of Turkey</b>			
1. Friendly people	3,97	3,56	3,77
2. Safe country	3,19	2,94	3,07
3. Trustworthy people	3,46	3,09	3,28
4. Pleasant people	3,81	3,44	3,63
5. Ideal to live	2,80	2,27	2,54
6. Ideal to visit	3,88	3,44	3,66
Average	3,52	3,12	3,32

Destination Beliefs of Turkey			
1. Appealing scenery	4,19	3,77	3,98
2. Suitable accommodation	3,41	3,11	3,26
3. High quality attractions	3,82	3,37	3,60
4. Lots to do and see	4,12	3,73	3,93
5. Good value for the money	4,21	3,56	3,89
6. Good tourism destination	4,17	3,64	3,91
Average	3,99	3,53	3,76

Wilcoxon T test (  $p > 0,05$  )

Table 5: Information Sources about Turkey (%)

	Sweden	The NL
Things I learnt about Turkey at school	35,05	44,63
Things I saw on TV, newspaper, etc. about Turkey	72,99	82,64
Things I experienced in Turkey	30,87	36,36
Turkish immigrants who live in my country	44,37	71,9
What my friends told me about Turkey	49,2	56,75
My family roots are in Turkey.	4,5	8,26
Turkish friends	21,86	31,68

It can be concluded from table 5 that Dutch people are more exposed to Turkish people and Turkey. They learnt more about Turkey on TV and at school than Swedes. Media, Turkish immigrants in the Netherlands and word-of-mouth (what friends told me) are the most important information sources. For Swedes, media, word-of-mouth and Turkish immigrants in Sweden are the most important information sources.

Recent protests that have been held in Turkey since 28 May 2013 initiated by about 50 environmentalists opposing the replacement of the 'Gezi Park' with a shopping mall in 'Taksim', at the heart of Istanbul. The protests developed into riots when environmentalists occupying the park were attacked with tear gas and water cannons by police which triggered nationwide demonstrations. The Western press referred to the 'Turkish Spring' at first,

but the events in the Arab world two years ago do not reflect today's situation in Turkey. Taksim Square is not Tahrir Square, Turkey is not an Arab country which has been ruled by a dictatorial one-man regime for the last three or four decades and Turkey is not in a political winter like those Arab countries. Turkey has a working democracy, governments come and go via national elections, minority rights have been improved again by this government and Turkey is adopting the European Union norms [44].

Table 6: What comes to your mind when you think of tourism in Turkey?

	Sweden		The NL	
	Fr	%	r	'
Cities	12 6	43, 45	1 78	42 ,48
Attractions	16	5,5 2	4 7	11 ,22
Activities	33	11, 38	2 3	5, 49
Natural beauty	86	29, 66	1 38	32 ,94
Sports related	2	0,6 9	1	0, 24
Food/drink	12	4,1 4	3	0, 72
Other	15	5,1 7	2 9	6, 92
Total	29 0	10 0	4 19	10 0

Respondents were given two blank spaces for this question and asked to give the first two things that come to their minds when they think of tourism in Turkey. Majority of the responses include Istanbul, Antalya, beach and sun.

## 7. Conclusion

Tourism marketing in Turkey began to be developed during the mid-1980s and it has great potential for competing in the international tourism industry. As a result of the comparison of Turkey (Mugla) and Spain (Mallorca) by German tourists, Mugla is perceived to have better accommodation services, facilities and activities, local transport services, hospitality and customer care, hygiene, sanitation and cleanliness, level of prices. Mallorca is

perceived to have better destination airport services and language communication [45].

Kozak and Rimmington conducted a research with British holidaymakers visiting Turkey. They found that friendliness of local people, value for money, attitude of staff working in tourism, safety and security, local transport, natural environment, speed of check-in and check-out at the resort airports, quality of restaurants and bars, responsiveness to customer complaints, food, facilities on the beach are ranked as the most positive elements of the tourism industry in Turkey. As the number of visitors coming from main tourist generation countries (especially from OECD countries such as Germany, the UK and Benelux countries) with inclusive tours increased, the accommodation capacity and other tourist facilities in major tourist destinations within Turkey increased as well [46].

Bridging the two continents, Turkey is a gateway to East and West. Turkey has different climatic regions ranging from temperate rainy climate of the Black Sea Region, to the continental in the Central Anatolia and subtropical Mediterranean on the south. From west to east there are also considerable differences and contrasting climatic regions, with hot summers and mild winters in the Marmara and the Aegean region to the Eastern Anatolia with extremes of temperature where the winters are long with heavy snow fall. The flora and fauna of Turkey are correspondingly diverse. With nearly ten thousand species, Turkey is a botanical paradise. Turkey is on the migration routes of birds and there are a number of areas which are the natural habitat for many different species, including rare ones [47].

## Turkish Tourism Industry - Today and Tomorrow

Over the last two decades Turkey has made considerable investments on infra and super structure. This also includes transport infrastructure such as improvement, modernization of airports and air terminals as well as construction of new ones. In addition to the international airports in the main cities and resort destinations, Turkey has domestic flights to all major cities and tourist centers. The transport infrastructure and the efficiency of services as well as advanced communication network system meet all the requirements of contemporary tourism [48].

The accommodation industry at present includes a range of facilities from the top quality, super modern deluxe category hotels and holiday

complexes, boutique hotels to the affordable ones. Although city hotels, summer resort hotels and holiday complexes constitute the greater part of the accommodation industry, there are numerous ski, winter resort and spa and convention hotels in various parts of the country. Most high standard hotels and holiday complexes have a variety of recreation, entertainment facilities. There are also a number of golf courses of international standard in various parts of the country [48].

To sum up, Turkey at present with its enormous tourism potential and a great diversity of its natural resources, historical treasures, cultural values and activities, life style, attractions, efficient, dynamic tourist industry offers wide selection of products that can satisfy the demand of different market segments including the most sophisticated and demanding traveler. Tourists are flocking to Turkey in increasing numbers. Records continue. The year 2009 has also seen a new record taking the annual tourist arrivals to over 27 million in spite of the situation in the world travel and tourism market [48]. That number reached to 29.3 million in 2012.

Turkey's tourism image is quite positive in Northern Europe where people crave for sun shine and mild climate. Visitors hold more positive beliefs than non-visitors. Travel experience does not have much influence on cognitive beliefs; it has more influence on affective beliefs. Once people have visited Turkey, after experiencing Turkish hospitality and running from one surprise to another where traditional and modern go hand in hand, they keep coming and recommending Turkey to their acquaintances.

Recent protests and its coverage by international media will inevitably have a bad effect on Turkey's international tourism receipts. However, there is a consensus of opinion supported by earlier research findings that the Turkish tourism will continue to grow at a higher rate than the European and the world average and the future prospects in the long term seem also to be very bright [48]. Turkey, as a developing country, adopted tourism not only as an alternative economic growth strategy, but also as a tool to create a favorable image on an international platform through exemplifying immediate implementation of an outward-oriented economic development policy [49].

Currently, the strong negative overtones are driving experts to suggest that Turkey should focus more proactively on identity, brand reputation and marketing. Every year, almost 30 million international tourists go back to their country happily

after experiencing destinations in Turkey. Especially Europeans, whose expectations are low before visiting Turkey, tend often to be impressed by the objects, artifacts and the people Turkey has on offer. Through word-of-mouth they recommend Turkey to their acquaintances spreading the country's positive image.

## 10. References

- [1] Hunt, J.D., "Image as a Factor in Tourism Development", *Journal of Travel Research*, Vol. 13 (3), pp. 1-7, 1975.
- [2] Anderssen, P. and Colberg, R.T., "Multivariate Analysis in Travel Research: A Tool for Travel Package Design and Market Segmentation", Proceedings of the Fourth Annual Conference, Sun Valley, Idaho, *Travel Research Association*, 1973.
- [3] Crompton, John, L., "An Assessment of the Image of Mexico as a Vacation Destination and the Influence of Geographical Location upon That Image", *Journal of Travel Research*, vol. 17 (4), pp. 18-23, 1979.
- [4] Gunn, C.A., "Vacationscape: Designing Tourist Regions", Austin: *Bureau of Business Research*, University of Texas, 1972.
- [5] Green, P.E. & Rao, V.R., "Conjoint Measurement for Quantifying Judgmental Data", *Journal of Marketing Research*, No. 8, pp. 355-63, 1971.
- [6] Green, P.E., "On the Design of Choice Experiments Involving Multifactor Alternatives", *Journal of Consumer Research*, No. 1, pp. 61-68, 1974.
- [7] Berens, G., Fombrum, Charles, J, Ponzi, L.J., Trad, N.G., Nielsen, K., in the *International Place Branding Yearbook Managing Reputational Risk*, Go, Frank M., and Govers, R (eds.), Basingstoke, U.K: Palgrave MacMillan, pp. 77-91, 2011.
- [8] Kaiser, C. and K. Friedrich, "Migration Decisions, Living Environments and Adjustments to Changing Needs of Elderly Germans on Mallorca", in A.M. Warnes, (ed.), Final Report ESF-Network, Sheffield, 2004.
- [9] Balkir, C., Kirkulak, B., "Turkey, the New Destination for International Retirement Migration,

Migration and Mobility in Europe”, *Edward Elgar Publishing*, MPG Books Group, UK, 2009.

[10] World Tourism Organization (2012), UNWTO Tourism Highlights. Available online (cited on 10 March 2013): [http://dtxtq4w60xqpw.cloudfront.net/sites/all/files/docpdf/unwtohighlights12enlr\\_1.pdf](http://dtxtq4w60xqpw.cloudfront.net/sites/all/files/docpdf/unwtohighlights12enlr_1.pdf)

[11] Turkish Ministry of National Defense, 2012. Available online: (cited on 7th June 2013). <http://www.msb.gov.tr/Birimler/GNPP/html/pdf/p1c2.pdf>

[12] Go, F. and Govers, *Introduction to the International Place Branding Yearbook Managing Reputational Risk*, Go, Frank M., and Govers, R (eds.), Basingstoke, U.K: Palgrave MacMillan, 2011

[13] Republic of Turkey-Ministry of Industry and Trade (2010), Turkish Industrial Strategy Document (2011-2014), Towards EU Membership. Available online (cited on 7 June 2013): <http://www.sanayi.gov.tr/Files/Documents/TurkiyeSanayiStratejisiInglizce.pdf>

[14] The Republic of Turkey Prime Ministry Investment Support and Promotion Agency, Invest in Turkey, 2012. Available online (cited on 16 June 2013): <http://www.invest.gov.tr/en-us/turkey/factsandfigures/pages/economy.aspx>

[15] Ogan, C.L. “Communication and Identity in the Diaspora: Turkish Migrants in Amsterdam and Their Use of Media”, Lexington Books, ISBN 0-7391-0269-9, 2001.

[16] Vermeulen, H. and Penninx, R. “Immigrant Integration: The Dutch Case”, Het Spinhuis, ISBN 90-5589-176-2, 2000.

[17] Baumann, G. and Sunier, T. “Post-Migration Ethnicity: De-essentializing Cohesion, Commitments, and Comparison”, Het Spinhuis, ISBN 90-5589-020-0, 1995.

[18] Barysch, K., “What Europeans think about Turkey and Why?”, Essay Partly Based on the CER Seminar on ‘Europe’s Public Opinion on Turkish EU Accession’ in Brussels on June 19th 2007, Centre for European Reform, 2007.

[19] Republic of Turkey, Ministry of Foreign Affairs, 2012. Available online (cited on 7th June 2013):

<http://www.mfa.gov.tr/reasons-between-turkey-and-sweden.en.mfa>

[20] Orbaiz, L. V. and N. Papadopoulos, “Toward a Model of Consumer Receptivity of Foreign and Domestic Products”, *Journal of International Consumer Marketing*, vol. 15, no. 3, pp. 101-126, 2003.

[21] Beerli, A. and J. D. Martin, “Factors Influencing Destination Image”, *Annals of Tourism Research*, vol. 32, no. 3, pp. 657-681, 2004.

[22] Echtner, M. C. and J. R. B. Ritchie, “The Measurement of Destination Image: An Empirical Assessment”, *Journal of Travel Research*, vol. 31, no. 4, pp. 2-13, 1993.

[23] Heslop, L. A. and N. Papadopoulos, “But Who Knows Where or When: Reflections on the Images of Countries and Their Products” in *Product-Country Images: Impact and Role in International Marketing*, *International Business Press*, New York, pp. 39-75, 1993.

[24] Statia, E., “A Comparative Analysis of Tourism Destination Image and Product-Country Image”, Ph.D. dissertation, Sprott school of business, Carleton university, Ottawa Ontario, Canada, 2007.

[25] Gartner, W. C., “Image Formation Process”, in *Communication and Channel Systems in Tourism Marketing*, M. Uysal and D. R. Fesenmaier, Eds., New York: Haworth Press, pp. 191-215, 1993.

[26] Baloglu, S. and D. Brinberg, “Affective Images of Tourism Destination”, *Journal of Travel Research*, vol. 35, no. 4, pp. 11-15, 1997.

[27] Walmsley, D. J. and J. M. Jenkins, “Appraisive Images of Tourist Areas: Application of Personal Constructs”, *Australian Geographer*, vol. 24, no. 2, pp. 1-13, 1993.

[28] Ward, L. M. and J. A. Russel, “The Psychological Representation of Molar Physical Environments”, *Journal of Experimental Psychology General*, vol. 110, no. 2, pp. 121-152, 1981.

[29] Coban, S., “The Effects of the Image of Destination on Tourist Satisfaction and Loyalty: The Case of Cappadocia”, *European Journal of Social Sciences*, vol. 29, no.12, pp. 222-232, 2012.

- [30] Russell, J. A. and J. Snodgrass, "Emotion and Environment", D. Stockols and I. Altman (Eds.), *Handbook of Environmental Psychology*, pp. 245–280, 1987.
- [31] Stepchenkova, S. and A. M. Morrison, "Russia's destination image among American pleasure travelers: Revisiting Echtner and Ritchie", *Tourism Management*, pp. 548-560, June 2008.
- [32] Ayyildiz, H. and Bilgin Turna, G., "Perceived Image of Spain and Germany as a Tourist Destination for Dutch Travelers", *Journal of Economics, Business and Management*, vol 1, no. 1, pp. 85-89, 2013.
- [33] Otto, J. E. and J. R. B. Ritchie, "The Service Experience in Tourism", *Tourism Management*, vol. 17 (3), pp. 165-174, 1996.
- [34] McIntosh, A. J. and Ciggs, A. "An Exploration of Experiential Nature of Boutique Accommodation", *Journal of Travel Research*, vol. 44 (1), pp. 74-81, 2005.
- [35] Ashworth, G. and Goodall, B. "Marketing in the Tourism Industry: The Promotion of Destination Regions", London: Routledge, 1988.
- [36] Chon, K. "The Role of Destination Image in Tourism: A Review & Discussion", *Tourist Review*, vol. 13 (Feb), pp. 2-9, 1990.
- [37] Mansfeld, Y. "From Motivations to Actual Travel", *Annals of Tourism Research*, vol.19, pp. 399-419, 1992.
- [38] Cooper, C., Fletcher, J., Gilbert, D., and Wanhill, S., "Tourism: Principles and Practice", London: Pitman Publishing, 1993.
- [39] Milman, A. and A. Pizam, "The Role of Awareness and Familiarity with a Destination: The Central Florida Case", *Journal of Travel Research*, vol. 33, no. 3, pp. 21-27, 1995.
- [40] Waryszak, R., "An Examination of the Role of Beneficial Image in Tourist Destination Selection", *Journal of Travel Research*, vol. 39 (1), pp. 37-44, 2000.
- [41] Bigne, J., E., Sanchez, M., I. and Sanchez, J., "Tourism Image, Evaluation Variables and After Purchase Behaviour: Inter-Relationship", *Tourism Management*, vol.22, pp. 607-616, 2001.
- [42] Goodrich, J., N., "The Relationship Between Preferences for and Perceptions of Vacation Destinations", *Journal of Travel Research*, vol. 17, no. 2., pp. 8-13, 1978.
- [43] Woodside, A. and Lysonski, S., "A General Model of Traveler Destination Choice", *Journal of Travel Research*, vol. 27 (spring), pp. 8-14, 1989.
- [44] Euronews, 3 June 2013. Available online (retrieved on 3 June 2013): <http://www.euronews.com/2013/06/03/is-this-the-turkish-spring-the-view-from-the-uronews-istanbul-correspondent/>
- [45] Kozak, M., "Measuring Comparative Destination Performance: A study in Spain and Turkey", *Journal of Travel and Tourism Marketing*, 13:3, pp. 83-110, 2002.
- [46] Kozak, M. and Rimmington M., "Measuring Tourist Destination Competitiveness: Conceptual Considerations and Empirical Findings", *International Journal of Hospitality Management*, 18, pp. 273-283, 1999.
- [47] TURSAB, Association of Turkish Travel Agencies, 2010. Available online (cited on 17 June 2013): [http://www.tursab.org.tr/en/statistics/development-of-turkish-tourism-in-brief/turkeys-tourism-potential-and-resources\\_1079.html](http://www.tursab.org.tr/en/statistics/development-of-turkish-tourism-in-brief/turkeys-tourism-potential-and-resources_1079.html)
- [48] TURSAB, Association of Turkish Travel Agencies, 2010. Available online (cited on 17 June 2013): [http://www.tursab.org.tr/en/statistics/development-of-turkish-tourism-in-brief/turkish-tourism-industry-today\\_1075.html](http://www.tursab.org.tr/en/statistics/development-of-turkish-tourism-in-brief/turkish-tourism-industry-today_1075.html)
- [49] Tosun, C. and Timothy, D.J., "Shortcomings in Planning Approaches to Tourism Development in Developing Countries: The Case of Turkey", *International Journal of Contemporary Hospitality Management*, vol. 13, no. 7, pp. 352-359, 1998.

# Dynamic Gravity Model: Evidence from Austria, Germany and Switzerland\*

Jan Průša

Institute of Economic Studies  
Charles University in Prague

E-mail: <jan.prusa@gmail.com>

Pavel Průša

Institute of Economic Studies  
Charles University in Prague

## Abstract

*This text uses the dynamic specification of the gravity model to analyze patterns of international trade of Austria, Germany and Switzerland. We study trade flows between Austria, Germany, Switzerland and the sample of their trading partners over the period 1995-2011 (2010 for Switzerland) with over 9,000 observations in total.*

*We conclude that there is strong evidence of persistent trade flows, which further advocates the utilization of the dynamic gravity setting. The strongly significant recession dummy for year 2009 is used to filter the effect of the recent economic crisis. In addition to standard gravity model variables, we test eleven institutional variables, of which level of education (Austria) and level of government spending (Germany and Switzerland) are strongly significant.*

*Finally, dummy variables for common currency suggest that the positive pro-trade effect of euro adoption may not be as high as argued in previous studies. Euro adoption however shows some persistence effect as lagged presence of euro in the past 1-2 years is more significant to international trade.*

## 1 Introduction

International trade and its patterns are an important factor not only for policy making of governments, but above all for output and investment choices of firms. Firms can use relatively cheaper labour and invest capital in some countries as they

know that they are able to export the goods produced there. Firms try to allocate their production most effectively to decrease costs and increase profits. This implies that firms can import some goods they need for production (intermediate products) and they can export goods to countries where they do not have production plants.

The incentive to analyze international trade is strengthened by various cooperative and non-cooperative actions of the countries. They might impose tariffs, enter various free-trade agreements and create single currency areas. The very last point was subject to a large debate. The question whether participating on projects such as currency union boosts or rather paralyzes trade has to be investigated in order to present evidence without prejudice that actions taken by governments have positive impact on economic development and welfare of the states.

In order to identify the most important determinants which shape the patterns of international trade, researchers designed the gravity model of trade. In its very simple version it uses mainly the economic size (gross domestic product) and distance between particular countries to predict bilateral trade flows between them. Its basic theoretical foundation as well as its name relates to the Newton's law of gravitation.

The question arises what is the correct specification of the gravity model and which kind of estimation approach to use. We need to be aware of technical irregularities and different behavioural re-

\*The support from the Grant Agency of Charles University (GAUK) under projects 684012 and SVV 265514 and the Grant Agency of the Czech Republic (GAČR) under project P402/12/0982 is gratefully acknowledged. All remaining errors are solely our responsibility.



sponses of the countries. The irregularities in the gravity model estimation are given by both the nature of panel data and the nature of gravity models as we observe bilateral trade flows between all countries of the sample. Thus any panel data can be estimated by two alternative sequences derived either from cross-section or from time series, the economic interpretation being different for each case.

In addition, countries' responses vary even when responding to similar impulses and their behaviour changes during time. This can occur due to several factors such as different institutional frameworks in countries, low or high enforceability of contracts, which can be hardly quantified. Last but not least the quality of infrastructure matters for magnitude of international trade and capital investments. For example, Kucharčuková, Babecký and Raiser (2010) study why countries in Southern and Eastern Europe are trading less with the rest of the world than other European countries. They emphasize the role of quality of institutions and changes in trade policies.

Baldwin and Taglioni (2006) show the main three mistakes made in the gravity model literature calling them gold, silver and bronze medal errors and also show that estimation without accounting for such errors leads to biases in the estimation. Egger (2002) looks at the discrepancy between actual and in-sample forecasted trade flows and argues this is mainly due to incorrect specification of the gravity model. He also looks at potential export possibilities of certain countries. Some countries might be below or above their trade potentials.

In this article we look at the dynamic version of the gravity model which showed up in the gravity model literature very recently and we test it empirically. The paper is structured as follows. The dynamic gravity model as introduced by Olivero and Yotov (2012) is presented in chapter 2. In chapter 3 we describe the data used for the estimation of the gravity model. Estimation of the gravity model together with the main results is presented in chapter 4. We use panel data sets for Austria, Germany and Switzerland. The last chapter concludes and summarizes the main findings.

## 2 Dynamic Gravity Model

### 2.1 Motivation: Persistent Effects in Gravity Models

The gravity model is commonly used to determine whether certain free trade agreement membership boosts up trade. Similarly it can be used to ask whether creating single currency area will support trade between the member states, and also between member and non-member states. This is a highly attractive field of study because of the Eurozone, since there has been a large debate if there are more advantages than disadvantages to being a Eurozone member, and for which countries the membership is more profitable and for which countries it is less. Very intuitively we might suppose that current bilateral trade flows are connected with bilateral trade flows experienced in previous period. This requires that we work with a dynamic version of the model.

Persistent trade effects will also occur in the case of tariffs. This stems from the possibility of impaired relationships between former trading partners. Countries which were trading with a country which just imposed a tariff might look for other trading partners. If they had a subsidiary in that country, the subsidiary might even be reallocated. Then at the time when the tariff is abandoned former relationships will not be rebuilt again immediately — this is what Olivero & Yotov (2012) call protection persistence. Similarly tariff cuts can result in relocation of production plants. Some examples can be found in Eichengreen & Irwin (1996) who study trade persistence and defend the use of lagged variables.

Another channel for persistence in international trade are the investment decisions of firms, which are influenced by the autocorrelation of bilateral trade flows. These choices on investment projects change the output and therefore influence the country size endogenously. From the trade flows dynamics follows that trade barriers do not have just an isolated impact in one period but influence capital accumulation dynamically. Because these factors are not accounted for in the estimation of the standard static gravity model, static estimation faces inconsistency.

For all the mentioned reasons it is sensible to add lagged values as further explanatory variables and work with a dynamic model.

## 2.2 Theoretical Framework

The model derived here is based on the study by Olivero & Yotov (2012) who present the theoretical foundations of dynamic gravity model. It combines the static gravity model introduced by Anderson & van Wincoop (2003) with the dynamic factors of asset accumulation and endogenous country size, by incorporating a production function. This is in contrast with the endowment economy where the income of both countries is just proxied by their GDPs.

### 2.2.1 The Set-up of The Model

We assume that each country produces only one good and that production is represented by the Cobb-Douglas production function with two inputs, labour and capital. For simplicity we assume that agents supply one unit of labour and we assume perfect inelasticity of labour supply. We can write that  $L \equiv 1$  and the standard term  $L^{1-\alpha}$  cancels out. Therefore the output of country  $j$  in period  $t$  is a function of capital and is of the form:

$$y_{jt} = a_{jt} K_{jt}^\alpha \quad \alpha \in (0,1) \quad (1)$$

In order to incorporate capital accumulation we write down the law of motion of capital stock which defines the development of capital stock over time.

$$K_{jt} = \Phi - (1 - \delta)K_{jt-1} \quad (2)$$

The capital stock in current period depends on the resources invested in order to accumulate capital and the previous capital stock which depreciates at rate  $\delta$ . Consumers maximize discounted present value of their lifetime utility. The maximization problem has the following form:

$$\max \sum_{t=0}^{\infty} \frac{1}{1+\rho} U(C_{jt})$$

where:

$$C_{jt} = \left( \sum_i \beta_i^{\frac{1-\sigma}{\sigma}} c_{ijt}^{\frac{\sigma-1}{\sigma}} \right)^{\frac{\sigma}{\sigma-1}} \quad (3)$$

$C$  stands for consumption,  $\beta$  is the positive distribution parameter,  $\sigma$  is the elasticity of substitution and  $\rho$  is the discounting factor. Investment

choices, aggregate consumption and their allocation is maximized subject to the following constraints:

$$K_{jt} = \Phi_{jt} - (1 - \delta)K_{jt-1} \quad (4)$$

$$\Phi = \left( \sum_i \beta_i^{\frac{1-\sigma}{\sigma}} I_{ijt}^{\frac{\sigma-1}{\sigma}} \right)^{\frac{\sigma}{\sigma-1}} \quad (5)$$

$$y_{jt} = \nu_{jt} K_{jt}^\alpha \quad (6)$$

$$y_{jt} = \sum_i p_{ijt} c_{ijt} + \sum_i p_{ijt} I_{ijt} \quad (7)$$

We have here homothetic and identical preferences which are modeled by a constant elasticity of substitution utility function. The investment parameter  $\Phi$  consists of investments in every region  $i$ . Equation 4 describes the law of motion of capital stock.

Consumption smoothing is enabled by the dynamic character of the problem; the aggregate utility of the consumer is maximized subject to the constraint in equation 7. In this setting the last budget constraint is modified by the second term, as not all resources are spent only on consumption but also on investments. As well as in the case of static gravity setting here we could decompose the price into two parts. The first part is the exporter's manufacturing price before any mark up and the second part are the bilateral trade costs.

### 2.2.2 Endogenous Production

After involving the assumption that market clears we obtain the structural gravity model given by the equation:

$$X_{ijt} = \frac{y_{it} y_{jt}}{y_t} \left( \frac{t_{ijt}}{\pi_{it} P_{jt}} \right)^{1-\sigma} \quad (8)$$

Now we come to the part where we incorporate the actual dynamic nature of the model. We want to include endogenous capital accumulation which is represented by the law of motion of capital stock and endogenous production. We put together 4 and 6 by firstly expressing equation for  $K$  which is  $K = \left( \frac{y_{jt}}{p_{jt}} \right)^{\frac{1}{\alpha}}$  and by using  $\Theta = \frac{\alpha \delta}{(\rho + \delta)}$  we get

$$\left( \frac{y_{jt}}{p_{jt}} \right)^{\frac{1}{\alpha}} = \Phi_{jt} + (1 - \delta) \left( \frac{y_{jt-1}}{p_{jt-1}} \right)^{\frac{1}{\alpha}} \quad (9)$$



$$\left(\frac{y_{jt}}{p_{jt}}\right)^{\frac{1}{\alpha}} = \Theta \frac{y_{jt}}{p_{jt}} + (1 - \delta) \left(\frac{y_{jt-1}}{p_{jt-1}}\right)^{\frac{1}{\alpha}} \quad (10)$$

We will use the structural gravity model equation in 8 which we will plug in for the lagged value in 10 and we get an expression for the output depending on the lagged trade, output in the world economy and multilateral resistance terms. We will do this in several steps. We firstly express  $y_{jt-1}$

$$y_{jt-1} = X_{ijt-1} \frac{y_{t-1}}{y_{it-1}} \left(\frac{t_{ijt-1}}{\pi_{it-1} P_{jt-1}}\right)^{\sigma-1} \quad (11)$$

Equation 10 then becomes

$$\begin{aligned} \left(\frac{y_{jt}}{p_{jt}}\right)^{\frac{1}{\alpha}} &= \Theta \frac{y_{jt}}{p_{jt}} + (1 - \delta) \left(\frac{1}{p_{jt-1}}\right)^{\frac{1}{\alpha}} \times \\ &\times \left[ X_{ijt-1} \frac{y_{t-1}}{y_{it-1}} \left(\frac{t_{ijt-1}}{\pi_{it-1} P_{jt-1}}\right)^{\sigma-1} \right]^{\frac{1}{\alpha}} \end{aligned}$$

This equation we multiply by the term  $\left(\frac{1}{p_{jt}}\right)^{\frac{1}{\alpha}}$  and exponentiate it to the power of  $\alpha$  in order to get the equation for the current output of region  $j$

$$\begin{aligned} y_{jt} &= \left[ \Theta y_{jt} p_{jt}^{\frac{1-\alpha}{\alpha}} + (1 - \delta) \left(\frac{p_{jt}}{p_{jt-1}}\right)^{\frac{1}{\alpha}} X_{ijt-1}^{\frac{1}{\alpha}} \times \right. \\ &\times \left. \left(\frac{y_{t-1}}{y_{it-1}}\right)^{\frac{1}{\alpha}} \left(\frac{t_{ijt-1}}{\pi_{it-1} P_{jt-1}}\right)^{\frac{\sigma-1}{\alpha}} \right]^{\alpha} \end{aligned}$$

### 2.2.3 Structural Dynamic Gravity

The derivation of an expression for bilateral trade flows is done by plugging the expression 12 into the structural gravity model.

$$\begin{aligned} X_{ijt} &= \left[ \Theta y_{jt} p_{jt}^{\frac{1-\alpha}{\alpha}} + (1 - \delta) \left(\frac{p_{jt}}{p_{jt-1}}\right)^{\frac{1}{\alpha}} X_{ijt-1}^{\frac{1}{\alpha}} \times \right. \\ &\times \left. \left(\frac{y_{t-1}}{y_{it-1}}\right)^{\frac{1}{\alpha}} \left(\frac{t_{ijt-1}}{\pi_{it-1} P_{jt-1}}\right)^{\frac{\sigma-1}{\alpha}} \right]^{\alpha} \times \\ &\times \frac{y_{it}}{y_t} \left(\frac{t_{ijt}}{\pi_{it} P_{jt}}\right)^{1-\sigma} \quad (12) \end{aligned}$$

<sup>4</sup>This is also related to the bronze medal error as in Baldwin & Taglioni (2006) who talk about the problem of deflating nominal GDPs. Then the question is which rate of inflation to use. It is definitely tempting to use that of USA but this might not come up to other countries. We might be also aware of whether we deflate the GDPs or their logarithms. We solve this by normalization of the price level.

Bilateral trade flows depend on gross domestic products of both countries and as also intuition suggests any barriers of trade negatively influence the magnitude of trade flows. The first term of the equation originated from employing endogenous production which endogenously changes country size. As was already noted above the key factor here is implementing lagged values both of trade flows and trade barriers. It is natural that bilateral trade flows are correlated over time and therefore it might be optimal to include the lagged variable of trade in the equation.

What we also see is that capital employed in previous period influences current production as its part after certain depreciation is still able for manufacturing. The second lagged variable is that of trade barriers. If in a country trade barriers are imposed it impacts the price level in that country. As the price level increases it gives rise to the marginal product of capital. Therefore output of such country increases as more capital is attracted by this increase in productivity. In the end this might positively affect trade flows which may also increase.

This is the possible positive impact of trade barriers which at first sight negatively influences trade flows. Hence there are two counteracting forces. The negative force is the impact of imposing trade barriers as such but there is this positive effect of possible capital attraction, accumulation and therefore also higher production and trade. The link between trade flows in previous and current period is by authors called trade persistence. The second link between trade barriers is denoted as protection persistence.

## 2.3 Size-adjusted Trade Flows

In order to be able to apply the gravity model on data we need to find an econometric specification of the model. We proceed by defining the size-adjusted trade when we divide the left-hand side in equation 12 by gross domestic products of both countries. The GDP of country  $i$  immediately vanishes while the GDP of country  $j$  we need to embody in the square brackets. Olivero & Yotov (2012) use

normalization of price level to one which has several advantages. The whole term containing the price levels vanishes in the square brackets and we get rid of the problem which inflation rate to use.<sup>4</sup>

$$\bar{X}_{ijt} = \left[ \Theta y_{jt}^{\frac{\alpha-1}{\alpha}} + (1-\delta) \bar{X}_{ijt-1} y_{t-1}^{\frac{1}{\alpha}} \left( \frac{y_{jt-1}}{y_{jt}} \right)^{\frac{1}{\alpha}} \right]^{\alpha} \times \left( \frac{t_{ijt-1}}{\pi_{it-1} P_{jt-1}} \right)^{\frac{\alpha-1}{\alpha}} \frac{1}{y_t} \left( \frac{t_{ijt}}{\pi_{it} P_{jt}} \right)^{1-\sigma} \quad (13)$$

By putting the GDPs of both countries on the left hand side this might mitigate the problem of heteroscedasticity which is mostly present.

## 2.4 Formulation for Empirical Investigation: Log-linearization

To log-linearize the last equation we firstly multiply both sides of the equation by the second term of the right-hand side. Then we can see that on both sides of the equation there are the same variables except for the fact that on the right-hand side they are with a subscript from previous period. So we can simplify both sides by putting the same variables into just one term with the only difference that on the right-hand side of the equation we add a subscript representing previous period.

We already added an error term to the equation to obtain the econometric specification of the dynamic gravity equation that constitutes the basis for estimation. Fixed effects are used to control for multilateral resistance terms and which also eliminate the world gross domestic product which is a time-variant variable. By using several rules for log-linearization we obtain the following equation as in Olivero & Yotov (2012):

$$\begin{aligned} \log(X_{ijt}) = & \beta_0 + (1-\delta)\log(X_{ijt-1}) + \\ & + (1-\sigma)\log(t_{ijt}) - \\ & - (1-\sigma)(1-\delta)\log(t_{ijt-1}) + \\ & + \beta_{it} + \beta_{jt} + \epsilon_{ijt} \end{aligned} \quad (14)$$

where

$$\begin{aligned} \beta_{it} = & -\log(\Pi_{it}^{1-\sigma}) + (1-\delta)\log(\Pi_{it-1}^{1-\sigma}) \\ \beta_{jt} = & -\log(P_{jt}^{1-\sigma}) + (1-\delta)\log(P_{jt-1}^{1-\sigma}) + \\ & + (\xi\alpha - 1)\log(y_{jt}) \\ & + (1-\delta)\log(y_{jt-1}) \end{aligned}$$

Equation 14 has all parts of the static gravity equation, and in addition it says that we include the lagged dependent variable as an explanatory variable. As we mentioned before this comes from the assumption that trade flows are expected to be autocorrelated over time so that trade flows experienced in previous years have impact on magnitude of today's trade flows. The trade flow pattern is persistent. Another difference between the static and dynamic gravity framework is due to the difference in multilateral resistance terms. We see that the parts of them, exporters and importers fixed effects vary over time.

The dynamic setting also allows to differentiate between time-invariant and time-varying trade barriers. We see that lagged value of trade barriers is included among the explanatory variables. We might expect that trade barriers introduced in previous periods have impact on trade flows in the future. But the trade barriers might affect trade flows by different ways in different periods.

## 3 Empirical Investigation

### 3.1 Data Description

We analyze trade flows between Austria, Germany, Switzerland and the sample of their trading partners. The sample of trading partners includes 211 countries in the case of Austria and 176 countries in the case of Germany and Switzerland. We analyze trade flows over the period 1995–2011 in the case of Austria and Germany and over the period 1995–2010 in the case of Switzerland. The total number of observations is 3587 for Austria and 2816 for both Germany and Switzerland.

Because some of the observations are missing we used interpolation to replace the missing items. It should not cause severe distortions as this was the case of only few variables and the number of missing values was small relatively to the total number of observations. On these balanced panel data we apply several econometric methods which are described below. Before that we make a more detailed description of variables used in the estimation.



### 3.1.1 Size-adjusted Trade Variables

In the standard static gravity model we have bilateral trade flows representing the dependent variables. Size of the economy represented by gross domestic product of the countries is among the explanatory variables. Nevertheless in our dynamic setting we transfer the GDPs of the countries to the left-hand side of the estimation equation and incorporate them into the trade flows. More precisely, we adjust bilateral trade flows by the production of the country of interest (which in our case is either Austria, Germany or Switzerland) and by GDP of the trading partner. We derived the theoretical equation in a logarithmic form in 14 and therefore we take the logarithm of this term.

Because size of the economy is already incorporated in bilateral trade figures, there are three main explanatory variables related to the gravity model: distance, number of inhabitants and the exchange rate deviation index. The last one measures the depreciation of the domestic currency relative to the foreign currency. The higher the ERDI the higher the depreciation and the better it is for firms to export.

### 3.1.2 Dummy Variables

We include the most typical dummies in gravity modeling, namely those regarding common language, common border and whether the country has access to the sea or is landlocked. If both countries have the same common language, share common border or when the trading partner is landlocked the dummy variable takes the value of one.

We further include three other dummy variables: the recession dummy, the euro dummy and the common colonial history dummy. The former one takes the value of one for the year 2009. The latter two take values of one if the trading partners use euro as their domestic currency and if there is historical cohesion between the country of interest and the trading partner. The reasons for including these dummies are straightforward. The recession dummy should account for the one-off impact of the financial crisis on international trade. Second, we want to look at potential positive pro-trade effects of having euro as the domestic currency. Third, we would expect countries with common colonial history to be trading more with each other than with other

countries.

### 3.1.3 Institutional Explanatory Variables

Finally we include institutional variables in the model. These variables bring additional information on the institutional development in the country. We selected the following:

- ★ government effectiveness denoted by *GOVEF*,
- ★ business freedom denoted by *BUSFR*,
- ★ trade freedom denoted by *TRFR*,
- ★ fiscal freedom denoted by *FISFR*,
- ★ monetary freedom denoted by *MONFR*,
- ★ government spending denoted by *GOVSP*,
- ★ investment freedom denoted by *INVFR*,
- ★ financial freedom denoted by *FINFR*,
- ★ enforcement of property rights denoted by *PRIGHT*,
- ★ education denoted by *EDUC* and
- ★ corruption freedom denoted by *CORR*.

The data were downloaded from the following databases: Eurostat, International Monetary Fund, World Bank, CEPIL Human Development Reports and the Heritage Foundation.

## 3.2 Econometric Approach

When it comes to estimating dynamic panel models there are mainly two estimators to be used. One option is the Arellano and Bond estimator, also called the difference-Generalized Method of Moments estimator (GMM). The other option is the Arellano, Blundell and Bond estimator which is better known as the system-GMM estimator.

Let us imagine a general dynamic model:

$$y_{it} = \beta y_{it-1} - \gamma x'_{it} + \epsilon_{it} \quad i = 1, \dots, N \quad t = 1, \dots, T \quad (15)$$

where  $\epsilon_{it} = u_{it} + v_{it}$  is a composite error term,  $u_{it}$  representing the individual effects and  $v_{it}$  representing the standard error term.

The dependent variable is correlated with the individual effects hence the lagged value of the dependent variable is also correlated with this part of the

composite error term. Therefore even without serial correlation of the error term, standard OLS estimation will be biased and inconsistent. Fixed effects estimator will be consistent for time going to infinity but it will be biased. Even by de-meaning transformation there is correlation between the lagged dependent variable and the error term causing the random effects estimator to be biased.

One option to address this issue is to use instrumental variables estimation (IV) called the Anderson-Hsiao estimator. First difference the equation and use lagged values of the dependent variables as instruments.

$$\Delta y_{it} = \beta \Delta y_{it-1} + \gamma \Delta x'_{it} + \Delta \epsilon_{it} \quad (16)$$

where  $\Delta y_{it-1} = (y_{it-1} - y_{it-2})$ . The valid instrument is then  $y_{it-2}$  as it is not correlated with the error term,  $E(y_{it-2} \Delta \epsilon_{it}) = 0$ . This simple estimator is efficient in the homoskedasticity case.

The Arellano-Bond estimator is a GMM estimator of the equation that is differenced and as instruments it takes all valid lags, i.e. it uses more than one instrument. The system GMM estimator uses both the lagged levels and lagged differences of the dependent variable as instruments. It should be preferable to use the two-step GMM estimator since it is efficient under more general assumptions such as heteroskedasticity.

We conduct OLS estimation with dummies, fixed effects estimation, and both the one-step and two-step system-GMM estimator so that we can compare the estimated parameters.

## 4 Estimation Results

In the previous chapter we talked about the variables and econometric methods that could be applied on the estimation of the dynamic version of the gravity model. In this chapter we turn to the estimation and interpretation of the results. We want to analyze trade flows between country of our interest and its trading partners. Our countries of interest are Austria, Germany and Switzerland.

Our final estimation equation has the following form:

$$\begin{aligned} ATRADE_{ijt} = & \beta_0 + \beta \mathbf{x}_{ijt} + \\ & + \gamma_0 + \gamma_1 + \epsilon_{ijt} \end{aligned} \quad (17)$$

where the vector  $\mathbf{x}$  is composed as

$$\begin{aligned} \mathbf{x} = & [ATRADE_{-1}, ATRADE_{-2}, DIST, POPL, \\ & ER, LANG, BORD, HIST, LAND, \\ & RECS, EURO, EURO_{-1}, EURO_{-2}, \\ & GOVEX, GOVSP, INVER, FINFR, \\ & PRIGHT, CORR, EDUC]' \end{aligned}$$

Adjusted bilateral trade flows is our dependent variable which depends on its lagged value, distance, population and exchange rate volatility where all of them are in a logarithmic form. Further it depends on several dummies and institutional variables described above. As this equation consists of quite a lot of variables some of them are omitted due to correlation when applying certain econometric methods as is for instance the difference-GMM estimator.

### 4.1 Properties of Estimation Methods

Firstly we apply the standard OLS. We know that the OLS estimator is biased and inefficient under our setting. The OLS causes the coefficient to be biased upwards. Then we use the fixed effects estimator which is also not a desirable correct econometric approach. It does not control for the bias of the dynamic panel. The lagged values of the variables can not be used as instruments and in this case the coefficients will be biased downwards. Hence we might expect the reasonable value of the coefficient of the lagged dependent variable to lie somewhere in the interval where the lower bound is given by the coefficient obtained by the fixed effects estimator and the upper bound given by the coefficient obtained by the OLS. This should hold both for the difference-GMM and the system GMM estimator. The difference-GMM estimator is biased downwards though as it uses only lagged dependent variable as instruments or weak instruments. It also suffers from finite sample bias.

If heteroskedasticity is present valid inference cannot be made since standard estimates regarding error terms are inconsistent and testing for several assumptions will give invalid results as well. To care for the problem of heteroskedasticity econometricists tend to use robust standard errors and as we have already mentioned above it is the reason why GMM estimators are preferable. We want to assess the



validity of instruments, test the overidentifying restrictions and model's correct specification. There are several tests available and we will use the Sargan test. The Sargan test is very sensitive to weak instruments and in many cases it might reject the null hypothesis. In presence of heteroskedastic disturbances we can not test the validity of instruments with the use of Sargan test as its distribution is unknown in such case. Statistical software such as Stata/IC 12 provides results of Hansen test of overidentification if we care for heteroskedasticity.

We also need to test for serial correlation of the differenced disturbances. Error terms and their serial correlation determine the validity of instruments and which lags we should use. In every case in general the null hypothesis of no serial correlation in the first differenced errors is rejected. This does however not mean that our model is misspecified. Standard approach is to test for AR(1) and AR(2). In the latter case we do not reject that there is no serial autocorrelation in the differenced errors. We do not report standard p-values to determine the significance of the variable but we use z-statistics. The reason is that we could use t-distribution only for a small sample but if our sample is larger than thirty observations we use z-distribution. The differences between those two measures were in our estimation negligible.

## 4.2 Estimation Results for Austria

We talked about the magnitude of the coefficients when applying OLS and FE estimators. The coefficient of the lagged dependent variable obtained by applying the system GMM estimator should lie somewhere in between and such coefficient is considered to be reasonable. In our model with two lags of the dependent variable this would mean that a reasonable coefficient lies between 0.54 and 0.73. This was realized as the coefficient is 0.71. If we considered model with only one lag of the dependent variable, the coefficient should lie between 0.59 and 0.93 which was satisfied as the value was 0.843. We do not report the results for the model with only one lag but we concentrate on the case of two lags. The OLS and FE coefficients with standard errors and p-values are reported in tables 1 and 2.

What we are interested in are above all the signs of the coefficients. We can see that the coefficient of

the lagged dependent variable is positive and there is a significant influence of this explanatory variable. This highly supports the theory that bilateral trade flows are autocorrelated over time. Further variables of high concern are distance and population. The intuition would suggest that coefficients of both variables are associated with a minus sign. The higher the distance between the two trading countries the more difficult or the more costly it is for the states to trade. The variable population is supposed to measure the so called openness of the country. The more inhabitants live in that particular country the more open the country is and the less trade flows it experiences. Our estimation results support the theory. Both coefficients have a minus sign and are significant.

The common language and the common border dummies are expected to be associated with a positive sign. If trading partners are neighbours it is easier for them to trade than if the trading partner was located on the other side of the globe. This also relates to the distance variable. If a state is landlocked, has no access to the sea, it negatively influences bilateral trade flows. And we would also expect that in the year of recession, which had been prevailing for many years but we take into account only the main year 2009, we expect that this would also negatively affect trade flows. We see that this consideration is confirmed by the estimation results again. Explanatory power of the common colonial history dummy is not straightforward as it was quite sensitive to the estimation techniques applied. The effect of adopting euro and using it as domestic currency has positive effect on trade flows. Its positive effect is lower than estimated by the static gravity model though. We suspect that the positive effect of euro is biased upwards in the static gravity model. The results of one-step and two-step system GMM estimations are reported in tables 3 and 4.

We also conducted Anderson Hsiao estimation which is the two-stage least square estimator, one-step difference-GMM, two-step difference-GMM estimation and experimented with number and kind of instruments. We also experimented with limits on the lagged variables used as instruments<sup>2</sup>. The system-GMM estimator is also sensitive to the number of instruments and how many instruments we use in the differenced and in the level equation. If

<sup>2</sup>The results are not reported.

we want to control for heteroskedasticity and report robust standard errors, we can investigate the result of the Hansen test. With the p-value of 0.136 it says that we do not reject the null hypothesis. The null hypothesis states that the instruments in the subset are valid or exogenous. If the null is heavily rejected we might reconsider the model's specification and the set of instruments. The Arellano-Bond test for AR(2) with p-value of 0.215 did not reject the null hypothesis of zero serial correlation.

We experimented with employing standard instruments as we could include them only in the difference equation or in the equation in levels. If the standard instruments are used only in the difference equation, the coefficient for the lagged value of the dependent variable when applying the one-step system-GMM is around 0.68. So it seems to be more reasonable. The variables describing historical relationships and level of corruption are now associated with a minus sign. Majority of the coefficient have higher values in both directions, both positive and negative. Two-step system-GMM estimator when including standard variables as instruments only in the difference equation yielded similar estimates. Both cases embody worse significance levels though. So we might face the trade-off between higher p-value of the Hansen test and worse significance of the variables. Turning to the case of one- and two-step system GMM with standard instruments used only in the equations in levels, the variables describing investment freedom and enforceability of property rights are associated with a minus sign. The signs relating to the coefficients of other variables remain the same. Let us also remind that the GMM-type instruments we leave the same.

If we study the case only with one lag of the dependent variable a minus sign is associated with the following variables: *GOVSP*, *INVFR*, *FINFR*, *PRIGHT* and *CORR*. Regarding the two-step estimation the only difference in signs relates to the variable *CORR*. The one-step and two-step system-GMM estimators when standard variables used as instruments used in difference equations yield similar results as in the case of two lagged dependent variables but there are more institutional variables associated with a minus sign. When standard instruments are employed only in the equations in levels results are very similar to those obtained by the standard one-step and two-step system-GMM

in the case of only one lag. All coefficients are reasonable. We are mostly interested in the coefficient and significance of the lagged dependent variables, euro and its lagged variables. There we obtain reasonable estimates.

The analysis suggests that bilateral trade flows are highly autocorrelated over time. Hence it might be appropriate to include them in the estimation and use dynamic version setting. Institutional variables seem to be very sensitive to different estimation techniques in contrast to the traditional variables used in gravity models. The effect of having euro as a domestic currency has significant pro-trade effects but its magnitude is lower than estimated by inconsistent and inefficient estimators. It suggests that coefficients obtained when using the static version of the gravity model are biased upwards. Thus the strong pro-trade effects arguments used by politicians of several countries to adopt euro are rather exaggerated.

### 4.3 Estimation Results for Germany

As in the case of Austria we focus also in this section mainly on four estimators: the standard OLS estimator, fixed effects estimator, one-step and two-step system-GMM. The estimated coefficient of the lagged dependent variable lies with its value of 0.782 between the values 0.58 and 0.792 as estimated by FE and OLS. Therefore the system GMM estimators yield reasonable estimates. The estimation yields similar results as in the case of Austria. The higher the distance between Germany and its trading partners the more difficult or more expensive it is to trade with each other and this higher distance negatively influences trade flows. This in analogy means that the lower the distance the higher the trade. This relationship is confirmed by the coefficient of the common border dummy. Germany experiences higher trade with neighbouring countries than with other trading partners.

The results show that if German language is at least one of the official languages spoken in the destination countries it positively influences trade even if this effect seems to be insignificant. With the variable *POPL* we measure openness of the states. The larger the country expressed in terms of the number of inhabitants or the more open a state is the more negatively it influences trade. Our estimation suggests that having euro as domestic cur-



rency does not positively effect trade flows. We would expect rather small positive pro-trade effect. This small negative could be caused by the already long-lasting strong historical connections between Germany and Eurozone members, also between Germany and states using euro but being Eurozone non-members. Hence adopting euro might not boost up trade significantly as the main trade and integration potentials were already exploited.

Important is to test for zero serial correlation of the differenced disturbances as it is an identifying assumption in the model. There is correlation in the first differenced errors, we always reject the null in the case of AR(1). Therefore we need to look at the case of AR(2) or higher. With p-value of 0.302 the test for zero serial correlation for AR(2) did not reject the null hypothesis. Hence we did not need to impose any limits on the number of lags used as instruments. The Hansen test of overidentification restrictions with the p-value of 0.111 confirms the validity of the instruments.

To see whether the contradictory effect of trade barriers suggested by the theory can be confirmed by the empirical investigation we add a further variable to the regressors. This additional variable *TRBARR* measures on a scale from one to nine the size of trade blocks imposed by the states. From the results presented in table 9 we support the argument suggested by the theory. The argument says that trade barriers still have their immediate negative impact on trade, in our case represented by the lagged values of trade barriers, but it suggests that trade barriers have contemporaneous positive effect due to capital accumulation, higher production and in the end higher trade. All estimation results for Germany are presented in table 5, table 6, table 12 and table 8.

#### 4.4 Estimation Results for Switzerland

In case of Switzerland we made some changes to the estimation equation again. We left out the common colonial history dummy which was very sensitive to the estimation techniques in the previous cases. Instead we add an explanatory variable indicating presence of certain trade barriers, another dummy variable. As we want to capture the persistence of trade barriers which we discussed in chapter 2 we include lagged values of the trade barriers vari-

able in our set of variables. Zero serial correlation is necessarily rejected for the first differenced errors. Because zero serial correlation is rejected not only for the first differenced errors we had to impose lag limits on the instruments used by the Arellano, Blundell-Bond estimator. The Hansen test of overidentification restrictions advocates exploitation of appropriate instruments.

By using the fixed effects estimator the coefficient of the lagged dependent variable has a value of 0.27. The standard OLS estimation yields an estimate of around 0.65. Therefore we would expect a reasonable estimate for the coefficient of the lagged dependent variable to lie somewhere in between. The one-step system GMM yields an estimate of 0.599 and by using the two-step system-GMM we obtain 0.605 as the value of the coefficient. Again we can see that trade flows from previous periods have significant influence on the magnitude of trade flows in the current period. This confirms the hypothesis of the persistence and autocorrelation of trade flows.

Higher distance between the countries and no access to the sea have significant negative effect on the trade flows. On the contrary common border has positive effect on trade again. We should pay attention to the effects of four following variables. Firstly there is this a bit surprising positive effect of openness of the trading partners. Secondly common language seems to have negative influence on trade in case of Switzerland. Four official languages in Switzerland are German Language, French Language, Italian Language and Romansh Language. We can ignore the Romansh language as approximately only 0.5% of the population in Switzerland speak this language. The French Language is an official language in almost fifty countries. Bilateral trade flows between Switzerland and some of those countries are small relative to other countries. Hence together with countries which have Italian and German Language as an official language the positive effect of common language, which we would expect, is dispersed. In contrast to the case of Austria we now assume the years 2009 and 2010 to be the years during which the crisis mostly influenced the economies. According to the coefficient we infer that recent financial crisis had positive significant effect on trade for Switzerland. On the other hand being Eurozone non-member has negative though

insignificant influence on its trade. It can be that European countries whose economies were destabilized by the crisis searched for near countries outside Eurozone which could be destination states of investments and which would be able to absorb more exports.

According to the results coefficients associated with minus signs relate to two of the eleven institutional variables in contrast to the case of Austria where there were four of them associated with a negative impact on the trade flows. Again these variables embody insignificance. All estimation results for Switzerland are presented in table 10, table 11, table 12 and table 13.

## 5 Conclusion

In this article we presented theoretical foundation of the dynamic gravity model and its application in the empirical part. The static gravity model has been very popular in empirical and international economics mainly thanks to its great usefulness and its good empirical fit. However the static version of the gravity model based on the endowment economy lacks several characteristics of bilateral trade flows. That is why dynamic gravity model has gained attention of the researchers in recent years. It tries to take the autocorrelation of bilateral trade flows over time and the persisting effect of trade barriers into account. In the empirical part of the article we study trade flows between Austria and her trading partners, Germany and her trading partners, and lastly between Switzerland and her trading partners. We employ several estimation techniques.

The theoretical expectations were very well supported by the empirical results. We saw that to the best explanatory variables belong the distance between trading partners, their populations and several factors which both countries even have or have not in common. Those include several dummies conveying whether they share common language and common border. Common language and common borders positively influence trade both in case of Austria and Germany. Negative sign of the language coefficient in case of Switzerland could be explained by the fact that more than one languages are spoken in Switzerland and therefore its expected positive effect on trade is dispersed. Higher distance and higher population negatively influence trade

both in case of Austria and Germany. Our recession dummy showed that trade flows were negatively influenced by the recent crisis. No access of some states to the sea has negative impact on trade. We must not forget to take into account the economic sizes of the countries. The GDPs of the states are captured by the adjusted trade flows term.

We further conclude that there is strong evidence on the autocorrelation of bilateral trade flows over time in all three cases and that we should take this phenomenon into account in the gravity model estimation. We have to also control for other explanatory variables which are correlated over time such as a free trade agreement membership. We need to take into account the possible endogeneity of some variables. Rather than looking at the exact magnitude of the coefficients, the signs and significance of the variables are more important.

We were interested in the magnitude of coefficients mainly for the euro variable and the lagged dependent variables. The results suggest that the pro-trade effects of euro adoption are biased upwards based on the static framework. Nevertheless there are positive pro-trade euro effects as evidenced by estimation of our dynamic version of the gravity model in case of Austria. The magnitude of the coefficient and the sign of the lagged dependent variable suggest that it is appropriate to use the dynamic version.

We also saw that not the magnitude of coefficients but rather the signs of the variables are sensitive to the structure of the instruments subsets. Despite of the availability of several estimation techniques of panel data (Anderson-Hsiao estimator, difference-GMM) we advocate the system-GMM estimator to be the most appropriate. But even by using this estimator we can experiment with the type of instruments and how many standard instruments are used in the difference equations and equations in levels. However the Sargan test of overidentification restrictions is very sensitive to the number of instruments.

The range of feasible explanatory variables is rather limited in gravity modeling hence the choice of appropriate variables, instruments and adding of new ones will remain a challenging task. The same holds for the choice of the appropriate estimation techniques and determining the optimal number and structure of the subsets of instruments.



Hence the usage of the gravity model will stay an important area for research.

## References

- [1] ANDERSON, E. J. (1979): "A Theoretical Foundation of the Gravity Equation." *American Economic Review* **69**, 1, pp. 106–116.
- [2] ANDERSON, E. J. & E. VAN WINCOOP (2002): "Gravity with Gravitas: A Solution to the Border Puzzle." *American Economic Review* Vol. **93**, No. **1**, pp. 170–192, March.
- [3] ANDERSON, E. J. (2011): "The Gravity Model." *Annual Review of Economics* Vol. **3**, January.
- [4] ANDERSON, E. J. & Y. V. YOTOV (2010a): "The changing incidence of geography." *American Economic Review*, pp. 2157–2186.
- [5] ANKOLAKIS, C. (2008): "Market Penetration Costs and the New Consumers Margin in International Trade." *NBER Working Paper No. 14214*, pp. 170–192, March.
- [6] BABEČKÁ KUČERÁČKOVÁ, O., J. EABECKÝ & M. RAISER (2010): "A Gravity Approach to Modelling International Trade in South-Eastern and the Commonwealth of Independent States: The Role of Geography, Policy and Institutions." *Working Paper Series 4*, Czech National Bank.
- [7] BALDWIN, R. & E. TAGLIONI (2006): "Gravity for Dummies and Dummies for Gravity Equations." National Bureau of Economic Research, *Working Paper 12516*, September.
- [8] BLUNDELL, R., S. BOND & F. WINDMEIJER (2000): "Estimation in Dynamic Panel Data Models: Improving on the Performance of the Standard GMM Estimators." The Institute for Fiscal Studies, *Working Paper 00/12*, June.
- [9] BAUM, F., Ch., M. E. SCHAFER & S. STILLMAN (2002): "Instrumental Variables and GMM: Estimation and testing." *Boston College Economics Working Paper 545*, November.
- [10] BRANDER, J. & P. KRUGMAN (1983): "A Reciprocal Dumping Model of International Trade." *Journal of International Economics* **15**: pp. 313–321.
- [11] DEARDORFF, A. V. (1998): "Determinants of bilateral trade: Does gravity work in a neoclassical world?." *The regionalization of the world economy* in Jeffrey Frankel (ed.). University of Chicago Press.
- [12] DIXIT, A. & J. STIGLITZ (1997): "Monopolistic Competition and Optimum Product Diversity." *American Economic Review* **67**, pp. 297–308.
- [13] EDGER, P. (2012): "An Economic View on the Estimation of Gravity Models and the Calculation of Trade Potentials.", pp. 297–312.
- [14] EDGER, H. & U. KRICKEMEIER (2009): "Firm Heterogeneity and the Labour Market Effects of Trade Liberalisation." *International Economic Review* **50**: pp. 187–216.
- [15] FEENSTRA, B. (2003): "Advanced International Trade." *Princeton University Press*.
- [16] FIDRMUC, J. (2008): "Gravity models in integrated panels." *Springer: Verhij*, pp. 435–446.
- [17] FRANKEL, A. J. (1997): "The changing incidence of geography." *American Economic Review*, pp. 2157–2186.
- [18] FRANKEL, A. J. & S. J. WELI (1993): "Trade Blocs and Currency Blocs." *NBER Working Paper No. 4335*.
- [19] HELPMAN, E. & P. KRUGMAN (1985): "Regional Trading Blocs in the World Economic System." *Institute for Internal Economics*, Washington, D.C.
- [20] HELPMAN, E. (1981): "International Trade in the Presence of Product Differentiation, Economies of Scale, and Imperfect Competition: A Chamberlin-Heckscher-Ohlin Approach." *Journal of International Economics* **11**: pp. 305–340.
- [21] HELPMAN, E., M. MELTZ & Y. RUBINSTEIN (2008): "Estimating Trade Flows: Trading Partners and Trading Volumes." *The Quarterly Journal of Economics* Vol. **123**(2): pp. 441–487, MIT Press.
- [22] JUDSON, A. R. & A. I. OWEN (1996): "Estimating Dynamic Panel Data Models: A Practical Guide for Macroeconometricists." *Federal Reserve Board of Governors*, January.

- [23] JUNG, B. (2012): "Gradualism and dynamic trade adjustment: Revisiting the pro-trade effect of free trade agreements." *Economics Letters* **115**: pp. 63–66.
- [24] MARTIN, W. & C. S. PHAM (2008): "Estimating the gravity model when zero trade flows are frequent." *Economic Series* **200803**.
- [25] MCCALLUM, J. (1995): "National Borders Matter: Canada-U.S. Regional Trade Patterns." *American Economic Review* **85(3)**, pp. 615–623.
- [26] MELITZ, M. (2003): "The Impact of Trade on Intra-industry Reallocations and Aggregate Industry Productivity." *Econometrica* **71**: pp. 1695–1725.
- [27] OLIVERO, P., M. & Y. V. YOTOV (2012): "Dynamic Gravity: Endogenous country size and asset accumulation." *Canadian Journal of Economics* **Vol. 45, No.1**, pp. 64–92.
- [28] PAPAZOGLOU, Ch., E. J. PENTECOST & H. MARQUES (2006): "A Gravity Model Forecast of the Potential Trade Effects of EU Enlargement: Lessons from 2004 and Path-dependency in Integration." *The World Economy*.
- [29] ROSE, K., A. (2000): "One Money, One Market: The Effect of Common Currencies on Trade." *Economic Policy*, pp. 7–45, April.
- [30] SALOP, S. (1979): "Monopolistic Competition with Outside Goods." *The Bell Journal of Economics* **10**: pp. 141–156.
- [31] SANTOS, S. & S. TENREYRO (2006): "The Log of Gravity." *Review of Economics and Statistics* **Vol. 88, No. 4**, pp. 641–658.
- [32] TINBERGEN, J. (1962): "Shaping the World Economy." *The Twentieth Century Fund*, New York.
- [33] VAN BERGELJK, A., G., P. & S. BRAKMAN (2010): "The Gravity Model in International Trade." Cambridge University Press.

Table I: Austria: OLS.

Variable	Coefficient value	Std. error	Pr(> t )
<i>ATRADE</i> <sub>-1</sub>	.7295924	.0361971	0.000***
<i>ATRADE</i> <sub>-2</sub>	.2062718	.0361498	0.000***
<i>DIST</i>	-.0712129	.0151327	0.000***
<i>POPL</i>	-.019606	.0066816	0.003***
<i>ER</i>	.3130722	.0438876	0.000***
<i>LANG</i>	.0636644	.0149314	0.000***
<i>BORD</i>	.0383546	.0155368	0.014**
<i>HIST</i>	.0027116	.0140506	0.847
<i>LAND</i>	-.0325052	.0165372	0.049*
<i>RECS</i>	-.0859007	.0181698	0.000***
<i>EURO</i>	.0435327	.0197405	0.028**
<i>EURO</i> <sub>-1</sub>	.0438548	.0220246	0.047*
<i>EURO</i> <sub>-2</sub>	-.0455462	.0175263	0.009***
<i>GOVEF</i>	.000462	.0004356	0.289
<i>BUSFR</i>	.0006233	.0006797	0.359
<i>TRFR</i>	.0002298	.000494	0.642
<i>FISFR</i>	-.0000756	.0004397	0.863
<i>GOVSP</i>	.0002338	.0003041	0.442
<i>MONFR</i>	.0003169	.0004263	0.457
<i>INVFR</i>	-.0002894	.0004538	0.524
<i>FINFR</i>	.0004108	.0004605	0.372
<i>PRIGHT</i>	-.0006454	.0004607	0.161
<i>CORR</i>	.0001208	.0004323	0.780
<i>EDUC</i>	.0015009	.0004587	0.001***
<i>const</i>	-.1693279	.0765307	0.027**

R-squared: 0.9125

Table 2: Austria: FE.

Variable	Coefficient value	Std. error	Pr(> t )
<i>ATRADE</i> <sub>-1</sub>	.5421925	.0464318	0.000***
<i>ATRADE</i> <sub>-2</sub>	.0974015	.0324693	0.003***
<i>DIST</i>	-	-	-
<i>POPL</i>	-.0771439	.2178889	0.724
<i>ER</i>	.5962225	.0842796	0.000***
<i>LANG</i>	-	-	-
<i>BORD</i>	-	-	-
<i>HIST</i>	-	-	-
<i>LAND</i>	-	-	-
<i>RECS</i>	-.0741987	.0163597	0.000***
<i>EURO</i>	.0436588	.0188345	0.021**
<i>EURO</i> <sub>-1</sub>	.0413185	.0171871	0.017**
<i>EURO</i> <sub>-2</sub>	-.0382297	.0189471	0.045*
<i>GOVEF</i>	-.0004838	.0009224	0.600
<i>BUSFR</i>	.0007207	.0008715	0.409
<i>TRFR</i>	.0010589	.0006785	0.120
<i>FISFR</i>	.0003477	.0009215	0.706
<i>GOVSP</i>	-.0011154	.0008654	0.199
<i>MONFR</i>	.0008556	.0006436	0.185
<i>INVFR</i>	-.0000799	.0006308	0.899
<i>FINFR</i>	.0000892	.0006227	0.886
<i>PRIGHT</i>	-.0009128	.0009261	0.325
<i>CORR</i>	-.0012469	.001049	0.236
<i>EDUC</i>	.0018309	.0027414	0.505
<i>const</i>	-1.00254	.2469782	0.000***

R-squared: 0.3261

F(19,210): 19.64\*\*\*

Table 3: Austria: One-step system GMM.

Variable	Coefficient value	Std. error	Pr(> z )
<i>ATRADE</i> <sub>-1</sub>	.7060205	.0351583	0.000***
<i>ATRADE</i> <sub>-2</sub>	.1943832	.0321255	0.000***
<i>DIST</i>	-.0968101	.0257694	0.000***
<i>POPL</i>	-.0340524	.0111101	0.002***
<i>ER</i>	.5543934	.0661995	0.000***
<i>LANG</i>	.1146613	.0286321	0.000***
<i>BORD</i>	.0743494	.0278088	0.008***
<i>HIST</i>	.0018365	.0221425	0.934
<i>LAND</i>	-.0610373	.0197367	0.002***
<i>RECS</i>	-.0898622	.0168705	0.000***
<i>EURO</i>	.0660975	.0226474	0.004***
<i>EURO</i> <sub>-1</sub>	.0466299	.0190649	0.014**
<i>EURO</i> <sub>-2</sub>	-.0440053	.0153877	0.004***
<i>GOVEF</i>	.0008679	.0004739	0.067
<i>BUSFR</i>	.0013142	.0007248	0.070
<i>TRFR</i>	.0005826	.0005018	0.246
<i>FISFR</i>	-.0001304	.000526	0.804
<i>GOVSP</i>	-.0000398	.000453	0.930
<i>MONFR</i>	.0005309	.0004919	0.280
<i>INVFR</i>	-.0005977	.0005119	0.243
<i>FINFR</i>	.0003619	.0004656	0.437
<i>PRIGHT</i>	-.000875	.0004492	0.051
<i>CORR</i>	.0001191	.0006306	0.850
<i>EDUC</i>	.0015901	.0005052	0.002***
<i>const</i>	-.2642969	.0944271	0.005***

---

Wald chi2(24): 21615.13\*\*\*

---

Table 4: Austria: Two-step system-GMM.

Variable	Coefficient value	Std. error	Pr(> z )
<i>ATRADE</i> <sub>-1</sub>	.7127431	.0348462	0.000***
<i>ATRADE</i> <sub>-2</sub>	.186012	.0315174	0.000***
<i>DIST</i>	-.0828874	.0283721	0.003***
<i>POPL</i>	-.0315596	.011474	0.006***
<i>ER</i>	.5346799	.0697524	0.000***
<i>LANG</i>	.0980525	.0307356	0.001***
<i>BORD</i>	.0909181	.0285257	0.001***
<i>HIST</i>	.0168707	.0259684	0.516
<i>LAND</i>	-.0586712	.0190099	0.002***
<i>RECS</i>	-.0855232	.0150711	0.000***
<i>EURO</i>	.0585805	.0251601	0.020**
<i>EURO</i> <sub>-1</sub>	.0607819	.0186051	0.001***
<i>EURO</i> <sub>-2</sub>	-.0525764	.0150516	0.000***
<i>GOVEF</i>	.0009047	.0004823	0.061
<i>BUSFR</i>	.0013414	.0007011	0.056
<i>TRFR</i>	.0005882	.0004862	0.226
<i>FISFR</i>	-.0000888	.0005322	0.867
<i>GOVSP</i>	-.0000494	.0004332	0.909
<i>MONFR</i>	.0005354	.0004485	0.233
<i>INVFR</i>	-.0004809	.0005256	0.360
<i>FINFR</i>	.000293	.0004877	0.548
<i>PRIGHT</i>	-.0010195	.0004841	0.035*
<i>CORR</i>	.0004187	.0006085	0.491
<i>EDUC</i>	.0014353	.0005291	0.007***
<i>const</i>	-.3152923	.105839	0.003***

Wald chi2(24): 16757.23\*\*\*

Table 5: Germany: OLS.

Variable	Coefficient value	Std. error	Pr(> t )
<i>ATRADE</i> <sub>-1</sub>	.7925534	.0460073	0.000***
<i>ATRADE</i> <sub>-2</sub>	.1467803	.0471611	0.002***
<i>DIST</i>	-.0503403	.0142275	0.000***
<i>POPL</i>	-.002365	.0059144	0.689
<i>LANG</i>	.0112927	.011712	0.335
<i>BORD</i>	.0261159	.0105395	0.013**
<i>LAND</i>	-.0101095	.0087883	0.250
<i>RECS</i>	-.0293632	.0122747	0.017**
<i>EURO</i>	-.0361816	.0215088	0.093
<i>EURO</i> <sub>-1</sub>	-.0573422	.0279101	0.040*
<i>EURO</i> <sub>-2</sub>	.0570724	.01974	0.004***
<i>GOVEF</i>	-.0001787	.0004009	0.656
<i>BUSFR</i>	.0003679	.000315	0.243
<i>TRFR</i>	-.0000147	.0003179	0.963
<i>FISFR</i>	-.0004213	.0002532	0.096
<i>GOVSP</i>	.0003204	.0001951	0.101
<i>MONFR</i>	-.0003364	.0002782	0.227
<i>INVFR</i>	.0002974	.0002674	0.266
<i>FINFR</i>	-.0002431	.0002568	0.344
<i>PRIGHT</i>	-.0001707	.0003133	0.586
<i>CORR</i>	.000336	.0002792	0.229
<i>EDUC</i>	.0002975	.0002549	0.243
<i>const</i>	.0505394	.0456722	0.269

R-squared: 0.8951



Table 6: Germany: FE.

Variable	Coefficient value	Std. error	Pr(> t )
<i>ATRADE</i> <sub>-1</sub>	.5801877	.0528355	0.000***
<i>ATRADE</i> <sub>-2</sub>	-.0088082	.0328296	0.789
<i>DIST</i>	-	-	-
<i>POPL</i>	-.4950003	.2092952	0.019**
<i>LANG</i>	-	-	-
<i>BORD</i>	-	-	-
<i>LAND</i>	-	-	-
<i>RECS</i>	-.0457782	.0118257	0.000***
<i>EURO</i>	-.0324475	.0189564	0.089
<i>EURO</i> <sub>-1</sub>	-.0576277	.0184848	0.002***
<i>EURO</i> <sub>-2</sub>	.0207254	.0128897	0.110
<i>GOVEF</i>	-.0012261	.0008699	0.160
<i>BUSFR</i>	-.0005027	.0005887	0.394
<i>TRFR</i>	-.0000627	.0003621	0.863
<i>FISFR</i>	-.0021121	.0004898	0.000***
<i>GOVSP</i>	.0005274	.0003378	0.120
<i>MONFR</i>	-.0000638	.0003608	0.860
<i>INVFR</i>	.0006714	.0004388	0.128
<i>FINFR</i>	-.0003841	.000373	0.305
<i>PRIGHT</i>	.0002399	.0005766	0.678
<i>CORR</i>	-.0000783	.0005275	0.882
<i>EDUC</i>	-.0045444	.0018703	0.016**
<i>const</i>	.1475721	.1577184	0.351

R-squared: 0.4884

F(18,176): 108.61\*\*\*

Table 7: Germany: One-step system-GMM.

Variable	Coefficient value	Std. error	Pr(> z )
<i>ATRADE</i> <sub>-1</sub>	.782042	.0462819	0.000***
<i>ATRADE</i> <sub>-2</sub>	.1355537	.0348855	0.000***
<i>DIST</i>	-.0698726	.0217497	0.001***
<i>POPL</i>	-.0031724	.0052463	0.545
<i>LANG</i>	.0057504	.015295	0.707
<i>BORD</i>	.0302439	.0152259	0.047*
<i>LAND</i>	-.0106105	.0130247	0.415
<i>RECS</i>	-.0313571	.0135113	0.020**
<i>EURO</i>	-.0356522	.021729	0.101
<i>EURO</i> <sub>-1</sub>	-.0579454	.0229268	0.011**
<i>EURO</i> <sub>-2</sub>	.0551716	.0148252	0.000***
<i>GOVEF</i>	-.0002205	.0005994	0.713
<i>BUSFR</i>	.0000462	.0003869	0.905
<i>TRFR</i>	-8.67e-06	.0002747	0.975
<i>FISFR</i>	-.0004354	.0002685	0.105
<i>GOVSP</i>	.0004903	.0002104	0.020**
<i>MONFR</i>	-.000366	.0003898	0.348
<i>INVFR</i>	.0002749	.0002729	0.314
<i>FINFR</i>	-.0003652	.0002741	0.183
<i>PRIGHT</i>	.0002139	.0004109	0.603
<i>CORR</i>	.0003106	.000409	0.448
<i>EDUC</i>	.0004579	.0002782	0.100
<i>const</i>	.0732871	.057197	0.200

---

Wald chi2(22): 31589.05\*\*\*

---

Table 8: Germany: Two-step system-GMM.

Variable	Coefficient value	Std. error	Pr(> z )
<i>ATRADE</i> <sub>-1</sub>	.7820903	.0463092	0.000***
<i>ATRADE</i> <sub>-2</sub>	.1354574	.0349437	0.000***
<i>DIST</i>	-.0702541	.0225443	0.002***
<i>POPL</i>	-.0035409	.0055005	0.520
<i>LANG</i>	.0034153	.020864	0.870
<i>BORD</i>	.0303045	.021336	0.156
<i>LAND</i>	-.010044	.0134439	0.455
<i>RECS</i>	-.0311229	.0135904	0.022**
<i>EURO</i>	-.0312829	.024692	0.205
<i>EURO</i> <sub>-1</sub>	-.0596899	.0243832	0.014**
<i>EURO</i> <sub>-2</sub>	.0535413	.0161211	0.001***
<i>GOVEF</i>	-.0002259	.0005987	0.706
<i>BUSFR</i>	.0000246	.0003947	0.950
<i>TRFR</i>	-.0000144	.0002795	0.959
<i>FISFR</i>	-.0004359	.0002697	0.106
<i>GOVSP</i>	.0004803	.0002161	0.026**
<i>MONFR</i>	-.0003766	.0003855	0.329
<i>INVFR</i>	.0002973	.000282	0.292
<i>FINFR</i>	-.0003436	.0002853	0.228
<i>PRIGHT</i>	.0001853	.0004272	0.664
<i>CORR</i>	.0003331	.0004159	0.423
<i>EDUC</i>	.0004597	.0002895	0.112
<i>const</i>	.0761489	.0603028	0.207

Wald chi2(22): 21213.83\*\*\*

Table 9: Germany: Two-step system-GMM.

Variable	Coefficient value	Std. error	Pr(> z )
⋮	⋮	⋮	⋮
<i>TRBARR</i>	.0115819	.0417232	0.781
<i>TRBARR</i> <sub>-1</sub>	-.0447715	.0469144	0.340
<i>TRBARR</i> <sub>-2</sub>	-.0196054	.0472843	0.678
⋮	⋮	⋮	⋮

Table 10: Switzerland: OLS.

Variable	Coefficient value	Std. error	Pr(> t )
<i>ATRADE</i> <sub>-1</sub>	.6461705	.0388106	0.000***
<i>ATRADE</i> <sub>-2</sub>	.2495771	.0357262	0.000***
<i>DIST</i>	-.0979066	.0233613	0.000***
<i>POPL</i>	.0822396	.0289507	0.005***
<i>ER</i>	.1822493	.050312	0.000***
<i>LANG</i>	-.0002311	.013892	0.987
<i>BORD</i>	.075672	.0294973	0.010**
<i>LAND</i>	-.0419216	.0177072	0.018**
<i>RECS</i>	.0294961	.0154624	0.057
<i>EURO</i>	-.0448489	.0183011	0.014**
<i>EURO</i> <sub>-1</sub>	-.0161493	.0269885	0.550
<i>EURO</i> <sub>-2</sub>	.0515858	.0242648	0.034*
<i>TRBARR</i>	-.025184	.0389631	0.518
<i>TRBARR</i> <sub>-1</sub>	-.0279617	.0579983	0.630
<i>TRBARR</i> <sub>-2</sub>	.0706143	.0452895	0.119
<i>GOVEF</i>	.0000829	.0006459	0.898
<i>BUSFR</i>	.0006789	.0004745	0.153
<i>TRFR</i>	.0002374	.0004388	0.589
<i>FISFR</i>	-.000108	.0003835	0.778
<i>GOVSP</i>	.0007874	.0003514	0.025**
<i>MONFR</i>	.0000297	.0004044	0.941
<i>INVFR</i>	-.0005385	.0003344	0.107
<i>FINFR</i>	.0000715	.000338	0.832
<i>PRIGHT</i>	.0005528	.0005608	0.324
<i>CORR</i>	.0008625	.0005597	0.123
<i>EDUC</i>	.0004027	.0004372	0.357
<i>const</i>	.0392891	.0734911	0.593

R-squared: 0.9339

Table II: Switzerland: FE.

Variable	Coefficient value	Std. error	Pr(> t )
<i>ATRADE</i> <sub>-1</sub>	.2674348	.0805804	0.001***
<i>ATRADE</i> <sub>-2</sub>	.0322098	.0274	0.241
<i>DIST</i>	-	-	-
<i>POPL</i>	.2184956	.404766	0.590
<i>ER</i>	.3885647	.0716772	0.000***
<i>LANG</i>	-	-	-
<i>BORD</i>	-	-	-
<i>LAND</i>	-	-	-
<i>RECS</i>	.021466	.0164428	0.193
<i>EURO</i>	-.0368626	.0190033	0.054
<i>EURO</i> <sub>-1</sub>	-.0036697	.0158609	0.817
<i>EURO</i> <sub>-2</sub>	.0082327	.0261441	0.753
<i>TRBARR</i>	-.017421	.0416715	0.676
<i>TRBARR</i> <sub>-1</sub>	-.0539056	.0461363	0.244
<i>TRBARR</i> <sub>-2</sub>	.0272056	.0453656	0.549
<i>GOVEF</i>	.0024966	.0012189	0.042*
<i>BUSFR</i>	.000241	.0007607	0.752
<i>TRFR</i>	.0001502	.0006699	0.823
<i>FISFR</i>	-.0004192	.0008769	0.633
<i>GOVSP</i>	.0006678	.0006236	0.286
<i>MONFR</i>	.0000345	.0007226	0.962
<i>INVFR</i>	-.0004687	.0005791	0.419
<i>FINFR</i>	.0002121	.0005683	0.709
<i>PRIGHT</i>	.0008477	.00086	0.326
<i>CORR</i>	-.0010079	.0007409	0.175
<i>EDUC</i>	-.0076114	.0031166	0.016**
<i>const</i>	.0442272	.2629354	0.867

R-squared: 0.1971

F(22,175): 13.81\*\*\*

Table 12: Switzerland: One-step system GMM.

Variable	Coefficient value	Std. error	Pr(> z )
<i>ATRADE</i> <sub>-1</sub>	.5998715	.0824514	0.000***
<i>ATRADE</i> <sub>-2</sub>	.3012415	.0814454	0.000***
<i>DIST</i>	-.1034845	.032922	0.002***
<i>POPL</i>	.0755283	.0215079	0.000***
<i>ER</i>	.2505731	.0615653	0.000***
<i>LANG</i>	.0018443	.0128109	0.886
<i>BORD</i>	.0765575	.0457814	0.094
<i>LAND</i>	-.0444244	.0174764	0.011**
<i>RECS</i>	.0419756	.0124964	0.001***
<i>EURO</i>	-.2184594	.3946648	0.580
<i>EURO</i> <sub>-1</sub>	.1823561	.4795296	0.704
<i>EURO</i> <sub>-2</sub>	.0476711	.429779	0.912
<i>TRBARR</i>	-.0147041	.0826359	0.859
<i>TRBARR</i> <sub>-1</sub>	.0269627	.089255	0.763
<i>TRBARR</i> <sub>-2</sub>	.0108411	.068222	0.874
<i>GOVEF</i>	.0002643	.0006262	0.673
<i>BUSFR</i>	.0004292	.0006131	0.484
<i>TRFR</i>	.0000891	.0005007	0.859
<i>FISFR</i>	-.0001512	.0004917	0.758
<i>GOVSP</i>	.0007496	.0004044	0.064
<i>MONFR</i>	.000325	.0005075	0.522
<i>INVFR</i>	-.0004233	.0003938	0.282
<i>FINFR</i>	-.0000722	.000389	0.853
<i>PRIGHT</i>	.0007172	.0007017	0.307
<i>CORR</i>	.0008251	.000581	0.156
<i>EDUC</i>	.000402	.0004727	0.395
<i>const</i>	.0463989	.1281081	0.717

---

Wald chi2(26): 47834.23\*\*\*

---



Table 13: Switzerland: Two-step system GMM.

Variable	Coefficient value	Std. error	Pr(> z )
<i>ATRADE</i> <sub>-1</sub>	.6054974	.0840726	0.000***
<i>ATRADE</i> <sub>-2</sub>	.2909749	.0825815	0.000***
<i>DIST</i>	-.0985892	.0273765	0.000***
<i>POPL</i>	.0822886	.0230547	0.000***
<i>ER</i>	-.237191	.0539652	0.000***
<i>LANG</i>	-.0020883	.0135613	0.878
<i>BORD</i>	.070106	.0400158	0.080
<i>LAND</i>	-.0414843	.015867	0.009***
<i>RECS</i>	.0412924	.0119826	0.001***
<i>EURO</i>	-.1629574	.2302222	0.479
<i>EURO</i> <sub>-1</sub>	.0704497	.3318609	0.832
<i>EURO</i> <sub>-2</sub>	.1012206	.2725483	0.710
<i>TRBARR</i>	.0017019	.0760928	0.982
<i>TRBARR</i> <sub>-1</sub>	.0288902	.0879825	0.743
<i>TRBARR</i> <sub>-2</sub>	-.0065756	.0709585	0.926
<i>GOVEF</i>	.000306	.0005882	0.603
<i>BUSFR</i>	.000402	.0004838	0.406
<i>TRFR</i>	.0000322	.0004465	0.943
<i>FISFR</i>	-.0003663	.0004015	0.362
<i>GOVSP</i>	.0006403	.000327	0.050*
<i>MONFR</i>	.0001189	.0004419	0.788
<i>INVFR</i>	-.0002349	.0003378	0.487
<i>FINFR</i>	.0000823	.0003636	0.821
<i>PRIGHT</i>	.0008075	.0005364	0.132
<i>CORR</i>	.0005352	.0005182	0.302
<i>EDUC</i>	.0004726	.0004886	0.333
<i>const</i>	.0487626	.1031385	0.636

---

Wald chi2(26): 38279.15\*\*\*

---



# Creative Tourism: Perception of Tourists, the Availability of Ownership and Possibility of Creative Tourism in Thailand

Teera Sindecharak,  
Faculty of Sociology and Anthropology, Thammasat University  
[teera.sd@gmail.com](mailto:teera.sd@gmail.com) , [tera@tu.ac.th](mailto:tera@tu.ac.th)

Col. NalikatibhagSangsnit  
Designated Areas for Sustainable Tourism Administration (Public Organization)<sup>2</sup>  
[nalikatibhag.s@dasta.or.th](mailto:nalikatibhag.s@dasta.or.th)

## Abstract

*This article aims to present a survey of the tourist's perceptions, the ownership's availability and the possibility of creative tourism in Thailand. Creative tourism has become a new tourist interest and support from both the public and private sectors in an effort to make it happen in Thailand like in other countries, under the initiative and drive of Designated Areas for Sustainable Tourism Administration (Public Organization) or "DASTA"*

*The study will not only explore the relevant literature and policies of government, the support of the private sector about the creative tourism in Thailand, but also the quantitative survey for 300 the visitors who join the activities. In addition, this study will get in- depth interview from the ownership about creative tourism arrangement. The selected to target creative tourism activities in the area of this study is to make the celadon at Suthep shop in Muang Koa district, Sukhothai province. This is in accordance with the rules of the so-called creative tourism activities.*

*The primary interest of this study found that there are a few tourists who actually understand the creative tourism. On the other hand, the potential cost of the ownership is the unique things that they have. This is interesting for learning and expectations in regard to the issue of economic rather than conservation. The results show that there are gaps among the perception of tourists, the preparedness of ownerships about creative tourism, and also the willing of support from both the public and private sectors to make creative tourism actually happen in Thailand.*

## 1. Introduction

Traveling can open your point of view, gaining more experiences, creating happiness and fun and also can be the beginning of learning new things. Nowadays, traveling trend becomes more active, so there are many travelers go to experience the tourist attractions. Moreover, there are the varieties forms of tourism that can attract big amount of tourists. Especially, a lot of tourists have flocked to Thailand for 22.35 million people in 2012 or one of third of Thai citizens, which increasing 3 million more people of .2011[1]

Today's traveling is more focused on the pursuit of money from visitor. They are encouraged to come into a tourist attraction to raise more income of community and country. As the result, degeneracy of the area will be occurred inevitably. For example, excess capacity of junk to get rid, incompetence of wastewater treatment, being destroyed of travel resource; such as stepping on coral area, correct stone and plants as souvenirs, which is careless of community tourism. In the other hand, community does not gain that much income but have more junk and wastewater. Therefore, providing knowledge and understanding to community could help them to prevent all bad situations. Presenting culture and tradition of community in correctly way is one of the interesting and unique forms of tourism, so called "Creation of Tourist Attraction". In addition, the strength of the community can retain the uniqueness and identity of the community which can attract tourists to travel until the day of next generation. The sustainable tourism development will be able to adapted but not changed. Travel resource management can be effective by responsible consuming, preserving, adjusting with

awareness of traditional wisdom and culture, so called "Creative Tourism".

The sustainable tourism development with creative tourism idea is needed to balance 3 aspects of community; economy, society, and environment. Too much concerning about gaining income for short period may lead to neglect of environmental management, attention of community welfare and also losing charm of community. On the other hand, too much focusing on culture and environment without adjustment to opening for tourist can be made public in community lack of enough income or having no income. The tourism development is necessary to concern all 3 parts in order to have a balance community and to develop a sustainable tourism destination. Therefore, the creative tourism as a sustainable approaches to tourism development in the country as well. In addition, creating the enjoyment for visitor could help to generate revenue for the community and could maintain community's uniqueness and identity as well. This article aims to study the awareness of creative tourism, availability of community resources or owners, and possibility of creative tourism in Thailand nowadays. This will be a new dimension of tourism in Thailand truly.

## 2. Creative Tourism in Thailand

Creative tourism began to be shaped up in 2001 by United Nation Educational, Scientific and Cultural Organization (UNESCO) with the universal declaration on cultural diversity as a tool to preserve and promote cultural diversity. In later years, UNESCO has initiated the Global Alliance for Cultural Diversity for the realistic of knowledge and culture exchanges. It is a tool to promote peace and sustainability of the community and the world. This project supports the policy of promoting cultural diversity of the world. [2] In 2014, UNESCO has shown the Creative Cities Network project for promote the development of creative industries that will lead to be a new form of cooperation in the international level of private, public and community. The Creative Cities Network of UNESCO has 7 categories of city. A city that will join a Creative City under a declaration adopted by UNESCO has to choose only one option either 1) Literature, 2) Craft and Folk Art, 3) Design, 4) Music, 5) Gastronomy, 6) Cinema, or 7) Media Arts. UNESCO has concerned and discussed not only the goal of sustainable peace, but also the possibility of creating a new tourism which travelers will experience being a part of tangible and intangible culture of the city. The Creative Cities Network and the new way tourism of

UNESCO emphasize the engagement through authentic experiences. It promotes active understanding of the specific cultural features of a place which conform to traveling behavior of new generation tourists.

The word "Creative Tourism" has been created by Crispin Raymond and Greg Richards. Their inspiration came from the behavior of new generation tourists, who came to Asia and South-East Asia; Thailand, Indonesia and Australia and wrote down their impression of learning in Thai massage in Chiang Mai and taking class of vegetarian cooking in Bali, Indonesia then having short period of taking care sheep and jillaroo in Australia. The word "Creative Tourism" is suitable to call this kind of tourism behavior which more emphasize on the importance of cultural heritage. They mutually created the meaning of new way of tourism as "Creative Tourism" which is "tourism which offers visitors the opportunities to develop their creative potential through active participation in courses and learning experiences which are characteristic of the holiday destination where they are undertaken". [3]

Later, the Creative Cities Network, held in October, 2006 with the aim to plan the Santa Fe International Conference on creative tourism was the first international creative tourism conference (2008). The "Creative Tourism" was defined as tourism directed toward an engaged and authentic experience, with participative learning in the arts, heritage or special character of a place. [4] This definition remain the initial principle in hands-on experiences that are cultural authentic and difference from Cultural Tourism, Ecotourism and Agri-Tourism.

In Thailand, creative tourism is very new idea although it has been discussed at international level for over 10 years. There is one government agency as a public organization under the name of Designated Areas for Sustainable Tourism Administration (Public Organization) or "DASTA" with important roles in determining the policies and plans to develop the special area for sustainable tourism and coordinating the local and central government agencies and public to participate the development of place attraction in the special area for sustainable tourism. DASTA recognizes the importance of tourism in the new format leading to the balance of economic, social and environmental by creative tourism. In year 2012, DASTA initially funded to develop the creative tourism protocol in 2 designated areas of total 7, which are Sukhothai-Srisatchanalai-Kamphaengphet Historical Park and Loei province. DASTA also funded to Faculty of Sociology and Anthropology,

Thammasat University to carry out the project. The main purposes of this project are to determine the definition of creative tourism and constructive criteria of creative tourism activities in the context of social of Thailand and to develop the creative tourism protocol in 2designated areas by searching the potential activities that can result in asustainable development for their community through creative tourism. The Working Group defines Creative Tourism being tourism to encourage tourists to exchange and learn for profound understanding the social, culture and environment values in the tourist attraction through a direct experience with the owner or owners of culture. The Creative Tourism will be consisted of area features and process features. The area features are 1)diversity and obviousness of cultural or natural and 2) awareness of the community value by the owners of culture. The process features are 1) sharing and learning across cultures, 2)direct experience with a culture, 3) process that led to profound understanding in the area, 4)does not destroy the value of the community and lead to the balance of economic, social and cultural. [5] The definition and criteria determined by the Working Group is the primary study of creative tourism in Thailand. By the introduction of DASTA and Faculty of Sociology and Anthropology, Thammasat University, the program has been used as a model to study the development of creative tourism in a later stage in Thailand.

In the area features, although Thailand has the capital and potential of activities available to visitors to share their learning and absorbing the spirit of the region through various activities scattered everywhere across the country but the understanding of tourists, especially Thai tourists, about creative tourism and the availability of activities available to tourists through the creative tourism process, which is considered part of the normal routine to do in life and led to the answer of feasibility, are questioned and doubted in Thailand. A study of the perception of Thai tourists about the readiness of the owner of the activity and the possibility of creative tourism are the major goal in this study by funded by DASTA as well.

### 3. Methodology

This study area is a special a historical space of Sukhothai-Srisutchanalai-Kampangpet where has been selected as world cultural heritage. The creative tourism related activity of community has taken a famous cultural heritage of the past for living. The target area is located at Meaung-Kao distric,Mueang, Sukhothai, where people produce the Sangkhalok

(Celadon). The study was conduct with sample consists of 300 Thai tourists who have been traveled to the target area within the month of May 2013. Questionnaire has been used as a tool for collecting data which consist of 3parts; 1) the general information of tourist (general information, experience of traveling, and visiting of Sukhothai province), 2)perception of creative tourism (attitude toward creative tourism and perception of creative) , and 3) definition of other kind of tourism (Eco-Tourism, Community Based Tourism, Cultural Tourism and Creative Tourism). The first 2 parts are the opening questions about the attitude. There are 7 questions which are the fifth level of LIKERT scale and 5 right or wrong questions. For the last part, it is the opening question about their own definition of other kind of tourism by their own free style of understanding.

In addition, it is not only the survey of tourists toward the perception of creative tourism, but also in-depth interview of the owners and Sangkhalok makers are also included. Auntie Nid (Mrs. SanongPrompet; wife of the ownerof the famousSangkhalok shop name “SuthepSangkhalok”) gave the interview about her 25 years experiences since the well-known shop have been established. Her shop has been selected to be the master of creative tourism potentially and sustainability. Availability, problems and solutions are included in the in-depth interview.

### 4. Results

From the 300surveys of tourists, there are only 122 surveys or %40.67of all which are reliable and quality. The quantity survey found that the numbers of female tourist are greater than male tourists; the number of working agepopulation is greater than elderly group. Their average age was 31years old and most engaged in entrepreneur, over than half of all gain less than20, 000baht per month and two of third are single. (Table 1)

Table 1 Amount and Percentage of Thai Tourist Samples by Characteristics

	Amount	Percentage
--	--------	------------

Sex		
Male	50	41.0
Female	72	59.0
Age (Mean 31, SD 8.54)		
Less than 25	30	24.6
25-44	85	69.7
More than or equal 45	7	5.7
Occupation		
Government Officer	15	12.3
Entrepreneur	48	39.3
Housewife	3	2.5
Private company employee	22	18.0
Student	22	18.0
Other	12	9.8
Education		
Lower than Bachelor degree	37	30.3
Bachelor degree	76	62.3
Higher than Bachelor degree	9	7.4
Income per month (Unit: Baht)	64	52.5
Less than 20,000	32	26.2
20,000-29,999	12	9.8
30,000-39,999	7	5.7
40,000-49,999	4	3.3
50,000-59,999	3	2.5
More than or equal 60,000	81	66.4
Marital Status	40	32.8
Single	1	0.8
Married		
Widow/Divorce/Separate		

The survey found that in past 3 years, most of all has a chance to travel either domestic or aboard. There is the only one who has been traveled to Sukhothai province for the first time and it is the first travel ever. Comparing with domestic traveling and aboard traveling, 90% are domestic travelers and 27% have a chance to travel aboard. There are 36% of Thai tourists prefer to travel in Asia and less than 5% prefer to travel to USA and Europe and none of Africa and Oceania.

The survey found that the main purpose of traveling for most of Thai tourists is resting on holiday, education, visiting relative, meeting/seminar, historical and special interesting as a hobby, and culture and religion respectively. The main sources of traveling information mostly come from friends and family advising. Internets, TV/radio, newspaper/guide book are other data sources respectively. (Table 2)

Table 2 Amount and Percentage of Thai Tourist Samples by Travel Experiences

Traveling Experience	Amount	Percentage
Traveling Purpose		
Resting on holiday	84	68.9
Culture and Religion	22	18.0
Education	32	26.2
Sport and Entertainment	9	7.4
Historical and Special Interest	24	19.7
Hobby	23	18.9
Visiting Relative	28	23.0
Meeting/Seminar	27	22.1
Others	3	2.5
Sources of Traveling information	79	64.8
Friends and Family	35	28.7
TV/Radio	68	55.7
Internet	19	15.6
News Paper/Guild Book	2	1.6
Others		

For 122 surveys, there are 69 people (57% who have traveled to Sukhothai province. There are almost half of travelers who travel as a day trip and over half of travelers who travel as overnight at least 3-1 nights. And more than four of fifth who decide to come back again by chance. The main reason of travel to Sukhothai province is for learning about history, feeling the world heritage area, and learning culture. Another reason is because of impression, missing some part of attraction, atmosphere, and interesting history.

The attitude of creative tourism toward Thai tourists found that more than 60% have good attitude and also support the form of creative tourism especially preserving the uniqueness of community, learning of culture, and development of community truly, also the relationship of among people, places and things (Table 3)

Table 3 Percentage of Thai Tourist Samples by Attitude toward Creative Tourism

	Strongly Agree	Agree	Mild	Disagree	Strongly Disagree
Convenience	-	1.	2	4	3
Unique Product	2	6	5.4	1.0	2.0
Culture Learning	4.6	4	2	0.	-
Joining	3	7.5	7.0	8	-
	4.4	4	1	0.	-
	2	8.4	6.4	8	0.

Activity	0.5	4	3	3.	8
Engagement	2	1.0	5.2	3	-
Expecting	3.0	4	2	0.	-
Unique Place	4	9.2	6.2	8	
Community	8.4	3	1	0.	
Tourism	4	7.7	3.1	8	
	1.0	4	1	-	
		0.2	8.9		

The survey of learning and understanding of creative tourism found that although tourists understand the value of community and the relationship between the tourist and host, but most of tourists still misunderstand about creative tourism especially the issue of inspiration for working and sharing the culture between tourists and hosts. This survey found that 7 out of 122 can give all 5 correct questions or 5.7% only. (Table 4)

Table 4 Percentage of Thai Tourist Samples by Perception What Creative Tourism is

What is Creative Tourism?	Yes		No	
	Amount	%	Amount	%
1. Inspiration for working tourism	109	8.9	13	10.7
2. Value of community tourism	116	9.5	6	4.9
3. Relationship between tourists and hosts	113	9.2	9	7.4
4. Living as local	103	8.4	19	15.6
5. Sharing the culture between tourists and hosts	111	9.1	11	8.9

Multiple regression analysis is shown the relationship of tourist attitude between creative tourism and general tourism. Thai tourists do not see any statistic significant differences. Even the statistic does not show the number of other sample tourists who can realize the difference significantly, (At alpha level 0.05) there is some source which show that the number of internet user has good attitude toward creative tourism more than tourists who searching the information from other source (Table 5)

Table 5 Estimated Multiple Regression Coefficients and Significance for Attitude toward Creative Tourism

	Beta	Significance
Sex (Ref: Male)	-	0.

Age	0.948	113
Occupation (Ref: Owner)	0.	0.
Education (Ref: None)	0.17	671
Income	-	0.
Marital Status (Ref: Single)	0.759	252
Number of Travel in 3 Years	0.	0.
Number of Travel in Domestic	249	730
Number of Travel in International	0.	0.
Traveling Purpose	206	458
Resting on holiday	-	0.
Culture and Religion	0.416	560
Education	0.	0.
Sport and Entertainment	819	271
Historical and Special Interest	-	0.
Hobby	0.791	288
Visiting Relative	-	0.
Meeting/Seminar	0.890	234
Sources of Traveling Data	-	0.
Friends and Family	0.249	708
TV/Radio	0.	0.
Internet	164	837
News Paper/Guild Book	-	0.
Have been to Sukhothai (Ref: None)	0.119	871
Frequency to Sukhothai	-	0.
Overnight (Ref: Day trip)	0.384	734
Not coming back (Ref: Never)	-	0.
	0.146	850
	0.	0.
	408	609
	-	0.
	0.356	629
	0.	0.
	010	990
	-	0.
	0.145	835
	-	0.
	0.527	447
	1.	0.
	212	065
	-	0.
	1.279	150
	0.	0.
	931	167
	-	0.
	0.070	417
	-	0.
	0.357	363
	-	0.
	0.250	765

Note: Constant = 26.792, R square = 0.191, MSE = 8.226

In the third part of survey, it is opened- question which define eco-tourism, local tourism, and cultural tourism. All tourists understand the meaning of different kind of tourism correctly. At least, tourists realize the real form of tourism. Most of them think that creative tourism is new and fun. Not much of tourist thinks about preserving, sharing culture, and be part of community.

Of the in-depth interview of significant persons who own famous Sangkhalok shop, SuthepSangkhalok, show than they provided equipment to support and manage the creative tourism by persuading tourists to join the activities such as teaching how to form the mock-up of sangkhalok and painting. There are many tourists interesting to this activity especial foreigner. Moreover, they also teach people how to make Sangkhalok in surrounding area for living. On the other hand, the owner is planning to create museum of Sangkhalok as a Thai style house. There will be only one limited edition for Sangkhalok in the world. This plan aims to share tourists who interested in Sangkhalok and to preserve Thai unique thing for the next generation.

Meanwhile, there is a little concerning about less appreciation of Thai tourists toward Sangkhalok. Most tourists will focus on cheaper products more than seeing the actual value. Tourists choose to buy Sangkhalok from manufacturing plant rather than purchasing at higher price product that made by hand. This situation could make the owner as Auntie Nid discourage to continue the plan. Sangkhalok will be gone over the time. Another problem is the local people in community do not interested in making Sangkhalok for living that much like gaining the wage return 300-200 per day. The owner gave up the plan because she could not be able to pay them that much. These obstacles make this creative tourism plan about Sangkhalok to be more difficult to happen.

Auntie Nid suggested the only one way to solve this problem is acknowledge the new generation to realize the important of our national uniqueness.

### **5. Conclusion and Suggestion**

Creative Tourism is a new form of travel to give priority to the engagement between guest and host to focus on the learning and authentic-active participation. The form and nature of tourism will give the opportunity for visitors and homeowners can share their learning and develop their potential of creativity mutually, which will cause to understanding specific cultural of the place. To this new trend, visitors will have a profound understanding of the area and have led

to such experiences adapted to the career of their own, and it also considered as an important tool to balance the sustainable economy, social and cultural of the community as well.

From the survey of 122 tourists of Thai tourists through questionnaire, although most tourists will have a positive attitude towards the creative tourism in direction encouraged to actually occur, but the basic perception and understanding of creative tourism are the barriers due to innovative its new form of tourism for Thailand. In addition, the publicity to what is the correct of creative tourism are lacked of be acknowledged and understood broadly. This is why it is urgent that relevant agencies, especially DASTA as an innovator and pioneer of creative tourism truly in Thailand to serve as an important tool to the development of sustainable communities, require playing their roles seriously. In the same time, they must support and promote the development of the area or community to be creative tourism in the actual in Thailand. We may start from the area or community having potential and unique activities. Simultaneously, we have to educate the owners and people in community to develop a neighborhood or area to be a creative tourist attractive and promote to enhance tourism at the community level to the national level and international level gradually and continuously.

### **6. References**

- [1] Immigration Bureau, Police Department, 2012 Available:  
<http://www.tourism.go.th/tourism/th/home/tourism.php?id=11> (Accessed 16 June, 2013)
- [2] Unesco, "Universal Declaration on Cultural Diversity [Online]", 2001, Available:  
<http://unesdoc.unesco.org/images/0012/001271/127160m.pdf> (Accessed 16 June, 2013)
- [3] Cohen, E. Thai Tourism Hill Tribes Islands and Open-ended Prostitution. Bangkok: White Lotus, 1996
- [3] MacCannell, D. The Tourist: A New Theory of the Leisure Class. New York: Schocken Boos, 1976
- [3] Raymond C, ATLAS Newsletter. November, 2000.
- [3] Smith, V. L.,ed. Hosts and Guests :The Anthropology of Tourism. Philadelphia: University of Pennsylvania Press. 1989

[4] Pleumarom. A. “How sustainable is Mekong tourism?” in R. Harris, T. Griffin and P. Williams (eds.) Sustainable Tourism A global perspective. Oxford: Elsevier Science ltd., 2002 pp.141-166

[4] Raymond. C. “What’s in a Name? The Origins of the Term ‘Creative Tourism’” in Wurzburger, R, et al. Creative Tourism: A Global Conversation: How to Provide Unique Creative Experiences for Travelers Worldwide. Santa Fe: Sunstone Press, 2010, pp.43-44

[4] Richards, G. “Creative Tourism and Local Development” in Wurzburger, R, et al. Creative Tourism: A Global Conversation: How to Provide Unique Creative Experiences for Travelers Worldwide. Santa Fe: Sunstone Press, 2010, pp.78-90

[4] Wurzburger, R, et al. Creative Tourism: A Global Conversation: How to Provide Unique Creative Experiences for Travelers Worldwide. Santa Fe: Sunstone Press. 2010

[5] Wisudthiluck, S, et al. Creative Tourism Model, 2012, pp.108-110



# From Industrial and Residential to A Tourism Precinct: The Rocks of Sydney

Ece Kaya, PhD Candidate

Institute for Culture and Society / Tourism and Heritage Studies,  
University of Western Sydney,  
[e.kaya@uws.edu.au](mailto:e.kaya@uws.edu.au)

## Abstract

*The transition from industrial use to a public creative use is a component of urban renewal, or public effort to revitalize aging and decaying inner cities. Urban renewal processes often involve competing needs, among these the desire to preserve historic locations and buildings, as well as the need to satisfy commercial opportunity and demands. These have sometimes translated into hard fought conflicts between developers, residents and governments about the public need and greater public good. Meanwhile, tourism has become a significant feature of the economy and urban structure of Sydney and also has played a major role in the transformation and re-development of industrial districts within cities that have traditionally accommodated commercial port activities.*

*This paper explores the role of tourism in heritage places. The Rocks has always been considered as a success story of regeneration with its proposed touristic, recreational, residential and commercial activities. However, this paper argues that tourism/leisure led developments create similar urban spaces and reduction of multi-identity structures to a single city image.*

## 1. Introduction

The transition from industrial use to a public creative use is a legacy of these maritime infrastructures. This transition is a component of urban renewal, or public effort to revitalize aging and decaying inner cities. Urban renewal processes often involve competing needs, among these the desire to preserve historic locations and buildings, as well as the need to satisfy commercial opportunity and demands. These have sometimes translated into hard fought conflicts between developers, residents and governments about the public need and greater public good. The use of some heritage-listed sites reflects the histories of the people associated with the site - whether as working wharves with commercial precincts or as iconic points of arrival and departure for

many Australians[1].Australia's history of trade, colonization, and settlement was dependent upon maritime sailing until the 1950s. Today, many docklands have been, or are in the process of being, transformed from industrial and sometimes squalid areas into contemporary cultural spaces. Many customs houses and other maritime buildings are usually prime waterfront locations with architecturally significant buildings [1]. Interestingly this is not entirely new. The history of The Rocks illustrates earlier attempts at urban regeneration (early 1900s) but without the additional dimension of heritage protection as part of this process [2].

## 2. Tourism and transformation

Tourism is generally investigated in terms of social, economic, cultural, and structural aspects of modernity. In other words, tourism is regarded as a modern phenomenon; and inherently peculiar to modern societies [3]. Furthermore, tourism is treated as the industry that serves experiences of modernity and leisure activities. In addition, tourism activity is regarded as a form of cultural capital that expresses 'being modern' for individuals in contemporary life; and an indicator or a marker that defines countries as modern/developed and pre-modern/underdeveloped [4]. Tourism has become a significant feature of the economy and urban structure of Sydney like many cities around the world and also has played a major role in the transformation and re-development of industrial districts within cities that have traditionally accommodated commercial port activities. These activities have become redundant and the areas have been substantially redeveloped with little of the original fabric remaining. Many inner city waterfronts have been transformed from working industrial ports into commercial, recreational and touristic areas. Historic waterfront areas have therefore emerged as a distinctive type of tourist district/precinct [5]. The Rocks was a mercantile port but when it developed in the early 19th century it was a fairly simple process in

terms of activities such as ships arrive, ships unloaded, goods were stored and then moved up. So the Industrial component in The Rocks is very small indeed. It's basically enlarged bond stores which were basically warehouses. Where goods came in, stored in the bond stores until the government, somebody paid tax and then it would go up into the wider world. Zukin (1995) argues that The main priority became to improve and aestheticize the outlook of the cities mobilizing public resources, embracing place marketing and image creation strategies, e.g. mobilizing culture and 'heritage industry' etc[6].

Roberts (2000), defines this transformation and restructuring process as "comprehensive and integrated vision and action which leads to the resolution of urban problems and which seeks to bring about a lasting improvement in the economic, physical, social and environmental condition of an area that has been subject to change" [7]. Tourism has a crucial place regarding economic development within this process [8]. The rationale of the industrial cities in 19th and early 20th century was industrial production, commerce of industrial products and houses for mass consumers and workers. However in "tourism urbanization", cities or urban areas are commoditized for the consumers of the tourism sector; and tourists go to tourism cities to consume not only the facilities of the city but also to consume the whole city. Page has discussed the positive economic impacts of tourism on urban places including the generation of income for the local economy, the creation of new employment opportunities for the city, and the encouragement of entrepreneurial activity. However, he also mentions some negative impacts such as inflationary costs in the local economy, a growing dependence on imported goods rather than locally produced ones, and seasonality in the consumption and production of tourism services [9]. Therefore, spatial reorganization and urban regeneration play a crucial role for the marketing of cities and this transformation action affects all infrastructure facilities, restorations of old buildings, reorganization of historical zones, and revitalizing the architectural style of the city. However, the implications and tourism interventions will be different from one city to another in order to reflect local context and identity such as architecture style, cultural heritage and local lifestyle.

### 3. Tourism in heritage districts

When looking at the increase of tourism in heritage places, it can be said that tourism is a valuable part of the economy. However, the growth of tourism cannot

be always considered as having a positive impact for cities. Because of the increase of tourism, many historic city centers started to lose their historical identity and suffer from overcrowding [10]. The Rocks first came to public prominence as a heritage issue in the mid-1960s when its proposed redevelopment, to be supervised by a new body, Sydney Cove Redevelopment Authority (SCRA), dramatically raised the issue of whether all of 'old Sydney' was about to disappear. There were proposals in the 60s for the broad scale clearing of the historic fabric and its replacement with a high rise development. Ashworth (2009) describes heritage as "the contemporary use of pasts". He also describes the heritage product as both diverse and vaguely demarcated [11]. Heritage is not only something that people wish to pass on generation by generation, it is also something that has become increasingly scientific so that preservation and survival is something that is created through a number of principles, processes and practices [12]. Dicks (2000) point out that heritage has become part of a burgeoning new 'culture of display' that capitalizes upon new forms of cultural consumption which can be problematic because on the one hand heritage has the potential to offer a representation of local life which is thought – provoking, accessible and which provides an expression of local identities [13] but on the other hand can become a form of commodification and performance that is either increasingly alienated from local communities or forms of new culture or both [14].

Davison and McConville (1991) indicate that heritage is now big business in Australia and since early 1970s there has been a rapid growth in the preservation, restoration and interpretation of historic buildings, landscapes and environments [15]. Pearson and Sullivan (1995) also describe Australia's landscape as a cultural place in holistic terms. They mention, in various contexts, heritage as historic places, prehistoric and historic sites and cultural resources [16] that encompass both Indigenous and European places.

Fainstein and Judd (1999) argue that cities are becoming more and more alike through the supply of chain hotels, restaurants and retail establishments to attract tourists for regeneration [17]. Ritzer (2000) states that the character of a city is often lost when local restaurants and shops are supplanted by large corporate chains [18]. Swarbrooke (2000) argues that standardization can lead to a loss of local identity for localities and suggests that it can reduce the long term appeal and sustainability of destinations [19]. Arguably, standardization is a major problem facing

many of the historic urban centers today as they are losing their uniqueness and perhaps their ability to attract tourists. Indeed, there is the danger of commercial overdevelopment and restricted public access, recreational open space and lower-income housing for local residents [20].

#### 4. Change of The Rocks

Urry (2002) defines the contemporary city as “the locus of consumption”. The cultural experience becomes a holistic process, where producer and consumer cohere in a “gazer” who “identifies” the symbolically significant. According to Urry (2002), the barrier between the heritage asset and the scenario that shapes the heritage experience has become increasingly blurred [21].

The Rocks is the historic area located on the Western side of Sydney Cove. The Rocks was the site of Australia's first prison, first hanging, first barracks, first store, first hospital, and first bakery. The Rocks is where the nation was born [22]. The Rocks has a unique location and important historic status, but first in 1900, an epidemic swept The Rocks, and the government decided to demolish large areas of slum houses. Then, during the construction of Harbour Bridge between 1924 and 1932, 800 families living in there have been displaced without compensation. During 1960s, new plans and recommendations have been prepared and the demolition was started in 1970. According to Daley (1982) Sydney experienced a unique property boom between 1968 and 1974 that reshaped the Central Business District (CBD) and expanded the city fringe. Industry and manufacturing relocated to outer Sydney and the resultant vacated sites were targeted for profitable re-development with the construction of high rise housing and office space [23]. The proposed demolition and re-development of both The Rocks and The Glebe Estate during this period galvanized a social movement for the protection of both upper and working class residential areas along with industrial heritage sites [24]. The Sydney Cove Re-development Authority, established in 1970 developing the first planning scheme including the approval for the constructing new office towers and thus extension of the Sydney CBD into The Rocks area. Under the sponsorship of Sydney Cove Re-development Authority (now the Sydney Harbour Foreshore Authority), The Rocks - the historic waterfront, port and warehouses - was transformed to a touristic space with stylish pubs and shops, restored buildings and walkways [25]. An Act providing for the constitution of the authority defining its powers, duties and functions

had been assented to on the 10<sup>th</sup> December 1968. Thus was born a scheme which supplanted the many considered by Governments and individuals for more than 70 years. The Authority was given the power to acquire, and grant leases but not to sell any of the land. The Authority was made responsible for raising its own funds by renting its properties or by way of a borrowing program [26]. Only nine historic buildings were to be retained, including Cadman's Cottage, St Patricks Church, Science House, Argyle Bond Store, the Ordnance Stores (ASN Co Building) and Campbell's Storehouse. Other historic buildings were marked for 'sympathetic redevelopment', but really a form of faradism. Everything else was to be demolished and replaced with multi-storey office and residential buildings and hotels. In the early 1970s, public opinion about large-scale redevelopment of areas including The Rocks began to change. However, local residents and key opinion makers wanted to maintain local communities. All redevelopment plans were halted for a period of years in The Rocks and the Authority tentatively began to carry out some minor developments itself and began the refurbishment of some of the buildings. The Argyle Centre was established as a crafts and retail venue and work began on 'restoring' the frontages of the buildings in George Street to provide a shopping Centre.

Turnbull (1999) describes that the post-war years from 1949 to 1965 were politically and culturally a case study of 'steady as he goes' in Menzies era. In 1955, Australia welcomed its one millionth post-war immigrants. In that immediate post-war period, the social changes were under the surface. However, in the middle of the 1960s they became to the light. The years of 1950s and 1960s were also the years of political conflicts because the Korean War in 1950, the Cold War after the Second World War and the fear of communism. The post-war economic boom did not really gather momentum until the early 1950s. A boom in building was from 1950s. In the second half of 1950s, industrial expansion was quick and substantial. Especially land values have risen from the 1970s onwards. Regarding the urban sprawl and the growth, The Cumberland County Council started to prepare a plan for Sydney within three years which would be an outline of the entire city's need. The main issues to be considered were: the size and location of arterial roads; the zoning and usage of land; water supply; the location and size of green belts and recreational areas; and the areas where the new settlements and new population should be located [27].

It was late 1950s, mostly around 1958 when the high-rise building boom was just beginning in Sydney.

Tall buildings were spreading on the foreshores. This pattern of Sydney building was also dominating city properties. The AMP project on Circular Quay, Caltex House on the Southern approaches to the Harbour Bridge and earlier than them the MLC building in North Sydney are the examples of commercial office blocks in CBDs. Munday (1981) argues that the years of 1950s were the years led too much of destruction of Australia. Politically, Menzies era was the time of believing in technology and its development. That is why they “were willing to let the resources be plundered as long as there were some crumbs for the rest from the cake baked for the few rich” [28].

Munday (1981) express the historic Rocks area of Sydney as the oldest part of European Australia and explain the time of serious threat by the end of 1973. High-rise buildings worth \$500 million were planned by the state government, through the Sydney Cove Redevelopment Authority. Against the project, NSW Builders Labourers Federation, at the request of The Rocks Resident Action Group imposed “green bans”. Public opinion for the retention and the preservation of the area was growth. The intensive demolition and development were stopped by combined power of citizens and unionists. It was an important message of giving citizens a say in the decision making process [28]. What signified many of the (re)development/renewal initiatives were the mobilization of the ‘cultures of the cities’, urban lifestyles for the imagined ‘urban’ future along entrepreneurial lines, which helped to turn cities from ‘landscapes of production’ into ‘landscapes of consumption’ [29].

## 5. Conclusion

The Rocks had a living community, it was full of residence. Some of them had been there for generations. They were strong characters and they formed strong allegiances with agencies like the National Trust and Builders Labourers Federation which is a very strange alliance as the National Trust is a very conservative union. They prevented the demolitions. They started a popular community process and a political process that led the government of the day changing its views and one of the things that interestingly reflects that is that the mission of the government policy the ‘Sydney co pre-development of property’ that remained the ‘Sydney co pre-development of property’ because it was no longer about redevelopment it was about active management. They developed an approach of essentially conserving. The Rocks is recognized as a place that comprises multiple layers of history and meaning, which should be

retained. The Rocks should be managed as a ‘living community’ with a growing residential population and a community that includes residents, tenants and visitors. The visual and historic setting of The Rocks and the current urban structure, including subdivision and characteristic built form, should be maintained. Original fabric of historic elements, including design details and patina, should be retained. Intangible aspects of the heritage of The Rocks, including significant uses and historic associations and meanings, should be conserved.

Tourism shouldn’t be dominance for the Rocks as the area is a mixed-use precinct. There is a whole other element to The Rocks which is based in residence and works in area every day and it’s a human sculpted place where you can still go and touch the rocks after which the rocks is named an 19 century masonry, everywhere you can walk up onto Cumberland street and go on the Argyle side and you can actually look at 18<sup>th</sup> century building remains that are made its very real, very visceral and that combination of uses works really well but it does require government intervention. It led to market forces there would be a market failure because what will happen is all the tourists uses that command the higher rents will predominate so the reason being for government interventions to ensure their integrity of the values of the place.

## 6. References

- [1] Urban Renewal: The Transformation of Australia's Docklands. (2009). Retrieved from, <http://australia.gov.au/about-australia/australian-story/urban-renewal>.
- [2] Kelly, M. (1997). *Anchored in a Small Cove: A History and Archaeology of The Rocks*. Sydney Cove Authority, Sydney.
- [3] Lash, S., Urry, J. (1994). *Economies of Signs and Space*, Thousand Oaks, London.
- [4] Shaw, G., & Williams, A. M. (2004). *Tourism and tourism spaces*. SAGE Publications Limited.
- [5] Griffin, T. and Hayllar, B. (2006). *Historic Waterfronts as Tourism Precincts: An Experiential Perspective*. *Tourism and Hospitality Research*, Volume 7, Issue 1, pp. 3 – 16.
- [6] Zukin, S. (1995). *The cultures of cities*.

- [7] Roberts, P. (2000). The Evolution, Definition and Purpose Of Urban Regeneration: Urban Regeneration. Eds: Peter Roberts and Hugh Sykes, Sage Publications, p. 9-36.
- [8] Gladstone, D. L., & Fainstein, S. S. (2001). Tourism in US global cities: A comparison of New York and Los Angeles. *Journal of urban affairs*, 23(1), 23-40.
- [9] Page, S. (1995a). *Urban Tourism*. p.119-120. London: Routledge.
- [10] Diekmann, A. and Gillot, L. (2010). Heritage and Tourism: A Dialogue of Deaf? The Case of Brussels. *Led Online E-Journals, Rivista di Scienza del Turismo Ambiente Cultura Diritto Economia* (in English), Vol 3, p. 263 – 280.
- [11] Ashworth, G. J. (2009). *Heritage and Economy*. Elsevier Ltd.
- [12] Timothy, D. J., & Boyd, S. W. (2003). *Heritage tourism*. Pearson Education.
- [13] Dicks, B. (2000). *Heritage, Place and Community*. UK: University of Wales Press.
- [14] Bruner, E. M. (2005). *Culture on Tour: Ethnographies of Travel*. University of Chicago Press.
- [15] Davison, G. and McConville, C. (Eds). (1991). *A Heritage Handbook*. Melbourne University Press.
- [16] Pearson, M. and Sullivan, S. (1995). *Looking After Heritage Places*. Sydney: Allen & Unwin
- [17] Judd, D. R., & Fainstein, S. S. (1999). *The tourist city*. Yale University Press.
- [18] Ritzer, G. (2000) *The McDonalozation of Society*, Thousand Oaks: Pine Forge Press.
- [19] Swarbrooke, J. (2000). Tourism, economic development and urban regeneration: a critical evaluation. *Developments in Urban and Rural Tourism*, Centre for Travel and Tourism, Sheffield Hallam University and University of Northumbria, Sunderland, 269-285.
- [20] Hall, P. (1993) Waterfronts: a new urban frontier, in R. Bruttonesso (ed. ), *Waterfronts, a New Frontier for Cities on Water*, Venice: International Centre Cities on Water, pp. 12-20
- [21] Urry, J. (2002). *The Tourist Gaze*. London: SAGE.
- [22] Sydney Cove Redevelopment Authority, (1979). *The Rocks Birthplace of a Nation*.
- [23] Daley, M.T. (1982). *Sydney Boom or Bust*. Sydney: Allen & Unwin.
- [24] Horvath, R. & Engels, B. (1985). *The Residential Restructuring of Inner Sydney*. In *Living Cities*. Sydney: Allen & Unwin.
- [25] Brenn, A. and Rigby, D. (1996). *The New Waterfront: A Worldwide Success Story*. London: Thames & Hudson.
- [26] Sydney Cove Redevelopment Authority, (1978). *The Rocks: A Revitalization Project*.
- [27] Turnbull, L. H. (1999). *Sydney: Biography of a City*. XD-US. Random House Australia.
- [28] Munday, J. (1981). *Green bans & beyond* (p. 105). Sydney: Angus & Robertson.
- [29] Zukin, S. (1998). Urban lifestyles: diversity and standardization in spaces of consumption. *Urban studies*, 35(5-6), 825-839.

# **A GIS-based Network Analysis for Planning Travel Routes: a Case of Ban Rai District, UthaiThani Province and Dan Chang District, SuphanBuri Province, Thailand.**

ChanitaDuangyiwa, SirivilaiTeerarojanarat  
Department of Geography, Faculty of Arts, Chulalongkorn University  
Chanita.d@chula.ac.th, [Sirivilai.t@chula.ac.th](mailto:Sirivilai.t@chula.ac.th)

## **Abstract**

*Network analysis is a well-known technique for geographers. In tourism, network analysis can be applied for investigating travel routes or road networks, setting the best routes between tourist attractions, testing scenarios for different trip purposes, etc. Derived information can help relevant public and private agencies to choose effective solutions for travel planning. In the case of Thailand, a wide variety of tourist researches have been conducted in order to promote or sustain tourist places. However, only a few studies have paid attention on economizing planning trips. This paper aims to demonstrate a way by which network analysis was implemented within a GIS environment to simulate road networks for self-drive tourists. Two types of algorithm – ‘exact distance’ and ‘hierarchical route’ in the ARCGIS network analysis module – were tested and compared. Results of the study were presented as maps and provided useful information to be incorporated into a trip planning process.*

## **1. Introduction**

Tourism is one of the most significant economic sectors in Thailand. A recent study by World Travel and Tourism Council [1] found that the total contribution of travel and tourism to Gross Domestic Product (GDP) in Thailand was approximately 58 billion US dollars (16.3% of total GDP) in 2011. The Ministry of Tourism and Sports proposed a Tourism Development Plan 2012-2016 [2], which consists of SWOT analysis and strategic plan for tourism industry in Thailand. Therefore, it is likely that the government has also recognized travel as a potential activity for promoting national economic development. The study of SWOT analysis demonstrated that the disadvantage of tourism in Thailand are lack of adequate information on database of tourist resources and transport networks. This limitation may lead to deficiency of

tourism planning for local authorities. As a result, the tourist attractions are clustered in some areas and the government could not expand these resources to new areas. Consequently, the integrated tourism management tools may be required to increase the economic efficiency of tourism in Thailand. For example, derivative data may support relevant public and private agencies in effective solutions for travel planning such as planning a day or multiple trips with minimum distance or time. The purpose of this paper is to simulate road networks for self-drive tourists using network analysis employed in Geographic Information System (GIS).

## **2. Tourism management tool: GIS & Network analysis technique**

Geographic Information System (GIS) could be define as ‘a collection of hardware, software, and associated with procedures to support spatial data acquisition, management, manipulation analysis, and display’ [3],[4]. Hall and Page [5] emphasized that GIS application, which is the beneficial improvement for research in applied geography, can be used as a decision-making support tool for geographers. It is highly likely that various studies related to tourism management have been conducted using GIS technology [5]-[10]. For example, the Tourism Secretary and the National Institute of Geography, Statistics and Information technology of Mexico used this application to examine the tourism in local areas and found that GIS is advantageous for the investigation of visitor behaviors and movements [6]. Another example is the research by Al qeed et al. [7], which employed the GIS technology to create travel pattern visualization and business possibilities for tourist attractions in Jordan.

Network analysis has long been embedded in GIS as a function to analyze transportation networks such



as finding the shortest path between two locations or minimizing total delivery cost. This technique widely exploited in marketing and business applications, especially in the field of logistics. There are various capabilities of network analysis related to tourism, such as application for identifying movements of tourist flows [11], planning for travel routes or road networks [12], calculating the best routes between tourist attractions [13], and testing scenarios for different trip purposes [14]. Shih [15] identified self-drive tourists as the tourists who develop their own journeys; as a result, the fundamental nature of this group is the feature of multiple destinations. Various researches showed that network analysis techniques are appropriate for investigating the network characteristics of tourism destination [15]-[18]. One example of this is the study by Chiou et al. [16] that used the combine techniques of evaluating dynamic segmentation and network analysis in GIS to explore the travel routes planning on forest trail networks in Central Taiwan. The researchers concluded that the information from GIS analysis and field investigation is reliable and suitable for decision-making in tourism management.

In case of Thailand, a study by Pongsri [18], for example, examined the Eco-tourism canal routes in Samut Songkhro province using network analysis function in GIS to analyze the shortest canal routes. Her results showed the potential of GIS and network analysis for tourism management in local area. However, up to now research studies involving the planning trips for multi-destination travel are not many; this study thus serves as an alternative to plan a trip by integrating the use of GIS network analysis to simulate road networks for self-drive tourists.

### 3. Study site

Ban Rai district, Uthai Thani province and Dan Chang district, Suphan Buri province are the adjacent areas in the central region of Thailand (Figure 1). The geographic coordinates of Ban Rai district are 15° 5' 2" north latitude and 99° 31' 16" east longitude. Its altitude is 161m above sea level. This district covers the approximate areas of 3,621.5 square kilometers. As for Dan Chang district, the geographic coordinates of are 14° 50' 30" north latitude and 99° 41' 50" east longitude. Its altitude is 62 m above sea level. This district covers the approximate areas of 1193.6 square kilometers. The study area is about a three-hour drive from Bangkok and has a potential to attract tourists in near future since it contains both cultural and natural tourist attractions. The area is also considered as a rest area or a stop before traveling to neighbouring regions.

However, it is probable that the majority of self-drive tourists may be not accustomed to these two areas and cannot select the place for the starting of the journeys. Furthermore, the repeated visitors may also want to explore new tourism areas or change to new travel program. Therefore, in the following sections this paper will briefly review the major research techniques employed in the research, including the explanation of the input data, which are tourist attractions and transports networks in Ban Rai district and Dan Chang district, some of the limitations are detailed, followed by the results of network analysis, and conclusions.

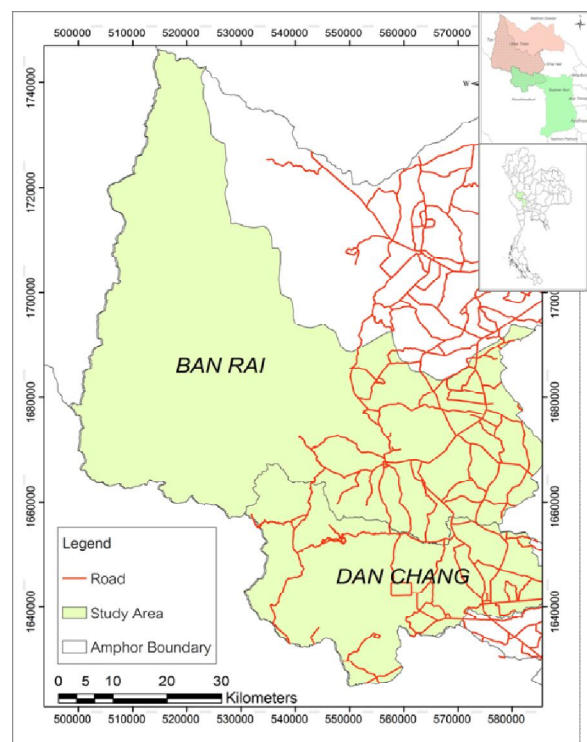


Figure 1. Location map of the study area

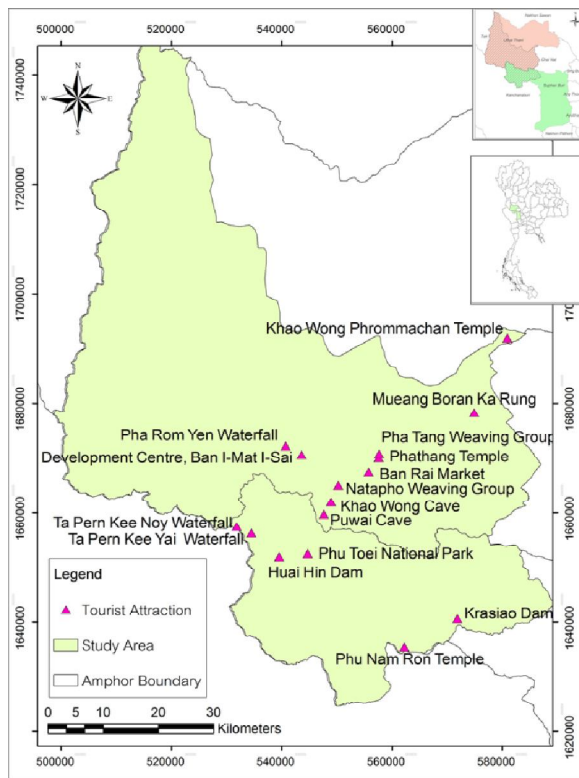
### 4. Methodology

#### 4.1 Data collection using GPS

Hand-held GPS was used to collect location of tourist attractions and some road networks. Available evidence indicates that geographical positions derived from GPS appear to be more reliable, accurate, and precise [19]. Geographic locations were recorded as x-coordinates and y-coordinates in GPS receivers and saved in the WGS84 datum. In this study, two methods of the hand-held GPS positioning were used which are manually and automatically. The first technique is to collect coordinate positions manually. The recorded points, which are called waypoints, are



collected by pressing the button on GPS-receive manually. This method was used to collect location of tourist attraction in the study area. The second method is to store the coordinate positions automatically. The coordinates are automatically saved as a track file. This method was used to collect some road networks, which are not available on the database [20]. GPS data then were imported into the ArcGIS Software using Universal Transverse Mercator (UTM) Zone 47 North coordinate system. In this step, the data imported into the ArcGIS software were the feature of the x- and y-coordinates. The attribute data need to be manually imported and linked to these spatial data to create the complete database for network analyzing process in the next step. Figure 2 shows the map of tourist attractions in the study area collected from GPS.



**Figure 2.**Map of tourist attractions in the study area

#### 4.2 Development of GIS database

The GIS software was used to present the geographical data as layers. At this stage, various data sets such as tourist attraction, roads, and administrative data were organized into geodatabase (Table 1). First, the location of tourist attractions were collected using

GPS as described in Section 4.1. Municipalities and most of roads network in the study site named Transport Fundamental Geographic Data Set (Transport FGDS) were derived from the Ministry of Transport. Because some parts of the road network are incomplete, additional road datasets were added using data from Google Earth and GPS. In Google Earth, additional roads were digitized from satellite images and some road segments were obtained from GPS during the field surveys. Besides, the attribute values such as time (minute) was manually added into the attribute table. Finally, the network datasets could be generated from these spatial and attribute data.

**Table 1.** Lists of Geographical data

Title	Content	Representation	Source data
Tourist attractions	Places in Ban Rai District, and Dan Chang District visited by Tourists	Point	GPS
Roads	Roads network in Ban Rai District, and Dan Chang District	Line	Ministry of Transport (2010), Google Earth, And GPS
Municipalities	Municipalities of Ban Rai District, and Dan Chang District	Polygon	Ministry of Transport (2010)

#### 4.3 Simulating road network for self-drive tourist

In this study, analysis of road network was applied to identify the possible paths for the movement or traveling of the self-drive tourists from one tourist attraction's location to another, so-called "routing" task. In GIS, an interconnected set of roads is represented as line features. Road intersections, turns, and stops are also included in the network database storing the connectivity of these features. Road intersections and turns can represent delay times while stops represent barriers in travelling. Roads and their segments can contain information or attributes such as road widths, surface types. These attributes may have impacts on the drivers' speed selection. For instance, if the road is wider, the drivers also tend to use higher speed [21]. If the amount of lanes increase, it is likely that the speed might be higher. Road surface is also

mainly considered as one of the most important factors for speed selection. For example, bumpy road can cause loud noise and vibration during driving. Road surface also has an impact on the perception of the drivers. Most drivers tend to drive with slower speed in a rough surface street [22]. Other factors could be personal appearance, social pressure, vehicle types, etc. The number of days spent for a trip was also used as a condition or choice for the self-drive tourists. During the road network simulation, distance of roads was automatically calculated along with the user-specified conditions and variables such as surface types in order to identify or model the shortest path along a road network.

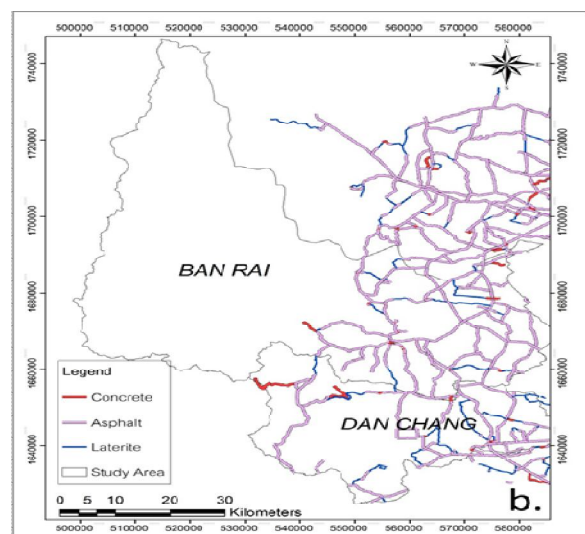
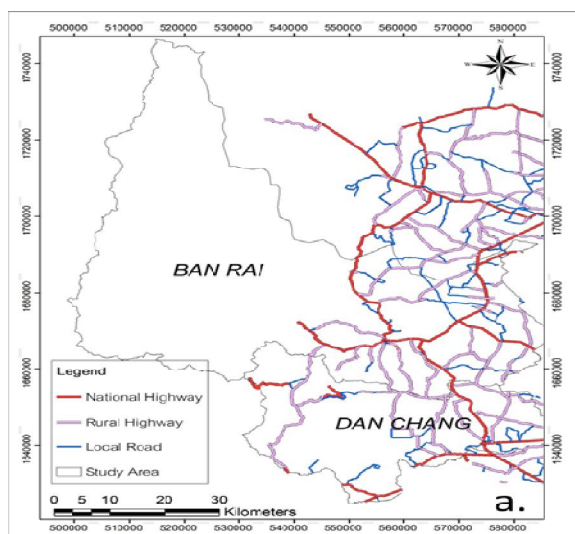
In our case, two types of algorithm – ‘exact distance’ and ‘hierarchical route’ in the ARCGIS network analysis module – were simulated and compared. The ‘exact distance’ algorithm refers to a means by which the shortest path, or the path having lowest distance, was preserved. Another algorithm, ‘hierarchical route’, refers to a means by which the road distance and other variables such as surface types are taken into account. Here, two variables – road types and surface types – were applied. Figure 3 shows map of road types and surface types in the study area. Four road types are motorways, national highways, rural highways and local roads. In order to calculate the travel time, different choices of speed (80 km/h, 60 km/h, and 40 km/h) were applied for each road type (national highways, rural highways and local roads) respectively. Three surface types are concrete, asphalt, and laterite. Three thematic routes from different number of days spent were set as choices or conditions: One-day trip, Two-day trip, and Three-day trip. For example, for one-day trip analysis, 7 tourist attractions were selected to simulate the routes. The lists of tourist

**Figure 3. Maps of Road classified by administrative a) and surface types (b) in the study area**

attractions used in different kinds of trips are shown in Table 2. It should be noted that because the study area is usually considered as a rest area before driving to neighbouring regions, e.g., *Huai Kha Khaeng Wildlife Sanctuary Thai World Heritage* in the western part of the study area, the simulation conducted in this study will be set as a one-way trip, not a return journey to the origin.

**Table 2. Lists of tourist attractions used in different kinds of trips**

One-day trip	Two-day trip	Three-day trip
Ban Rai Market	Ban Rai Market	Ban Rai Market
Krasiao Dam	Krasiao Dam	Krasiao Dam
Khao Wong Cave	Khao Wong Cave	Khao Wong Cave
Mueang Boran Ka Rung	Mueang Boran Ka Rung	Mueang Boran Ka Rung
Natapho Weaving Group	Natapho Weaving Group	Natapho Weaving Group
Pha Tang Weaving Group	Pha Tang Weaving Group	Pha Tang Weaving Group
The Social Development Centre, Ban I-Mat I-Sai	The Social Development Centre, Ban I-Mat I-Sai	The Social Development Centre, Ban I-Mat I-Sai
	Khao Wong Phrommachan Temple	Khao Wong Phrommachan Temple
	Pha Rom Yen Waterfall	Pha Rom Yen Waterfall
	Phathang Temple	Phathang Temple
	Phu Nam Ron Temple	Phu Nam Ron Temple
	Puwai Cave	Puwai Cave
		Huai Hin Dam
		Phu Toei National Park
		Ta Pern Kee Noy Waterfall
		Ta Pern Kee Yai Waterfall



## 5. Discussion of simulation results

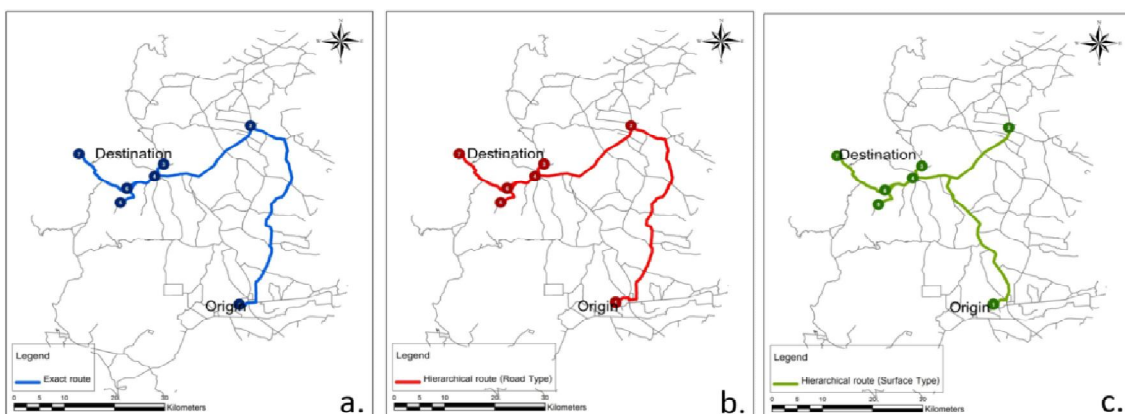
Figure 4-6 show the resultant maps of the best routes produced from different algorithms and the number of days spent. As mentioned earlier, a one-way trip simulation was applied. The origin and destination of routes in each trip were set to visit the same places in similar order. For a one-day trip as shown in Figure 4, the “hierarchical route (surface type)” algorithm used different routes from the other routes. As clearly seen, different routes between stop 1 (Krasiao Dam) and stop 2 (MueangBoranKa Rung) caused different travel times. For a two-day trip, in spite of different algorithms, the same routes were produced. This implies that the same travel pattern was suggested regardless of any algorithms used. For a three-day trip, various routes were produced such as

between stop 1 (Phu Nam Ron Tempel) and stop 2 (Krasiao Dam), between stop 2 and stop 3 (MueangBoranKa Rung), and between stop 4 (Khao Wong Phrommachan Temple) and stop 5 (Pha Tang Weaving Group). Comparison between these three routes was also shown in Figure 7.

Along with the resultant maps, comparison between distance and time (see Table 3) were also calculated within GIS environment. For a one-day trip, this suggests that in spite of similar distance in each route, hierarchical route (surface type) gave the best alternative, the fastest path to the destination. In case of a two-day trip, since the same travel pattern was used (see map in Figure 5), travel time and distance were the same. For a three-day trip, distance and time from hierarchical routes were less than those from exact distance algorithm.

**Table 3. Thematic route results (one-way distance)**

Result	One-day trip		Two-day trip		Three-day trip	
	Distance (km)	Time (minute)	Distance (km)	Time (minute)	Distance (km)	Time (minute)
Exact route	117	107	188	159	258	255
Hierarchical route (Road Type)	117	109	188	159	248	226
Hierarchical route (Surface Type)	117	96	188	159	248	226



**Figure 4. Maps of a one-day trip simulated from different algorithms (a) exact route (b) hierarchical route (road type) and (c) hierarchical route (surface type)**

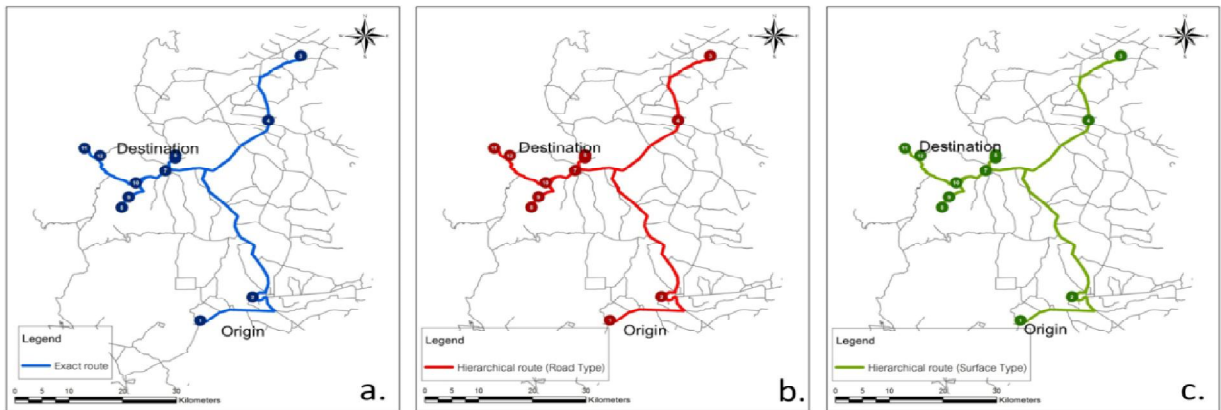


Figure 5. Maps of a two-day trip simulated from different algorithms (a) exact route (b) hierarchical route (road type) and (c) hierarchical route (surface type)

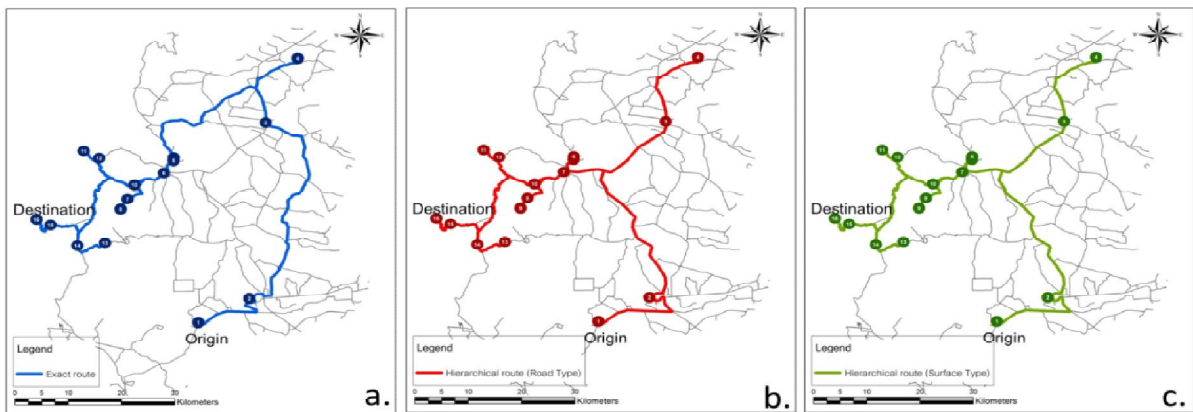


Figure 6. Maps of a three-day trip simulated from different algorithms (a) exact route (b) hierarchical route (road type) and (c) hierarchical route (surface type)

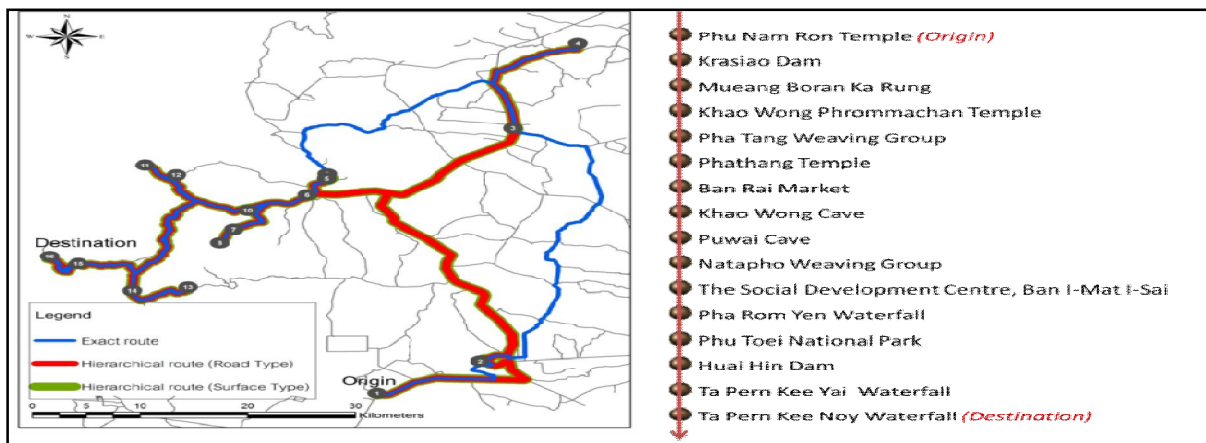


Figure 7. Map illustrating the comparison of routes for three-day trip simulation



All in all, this study showed that the GIS-based network analysis is very useful for route simulation. The repetitive tasks such as simulating routes with different variables/factors can be accomplished easily. It was proved that a GIS tool and network analysis module can save a lot of time to simulate routes and plan trips. However, the trip planning in this paper is still unrealistic because more information such as time

to spend for each tourist place is required to be included. The next stage of this research work, the potential information on tourist attractions from the research by Patnukao and Teerarajanarat [23], will be examined, weighed and converted into the number of hours spent at each place. Figure 8 gives an example of simulated tour package (3 days 2 nights) by adding the

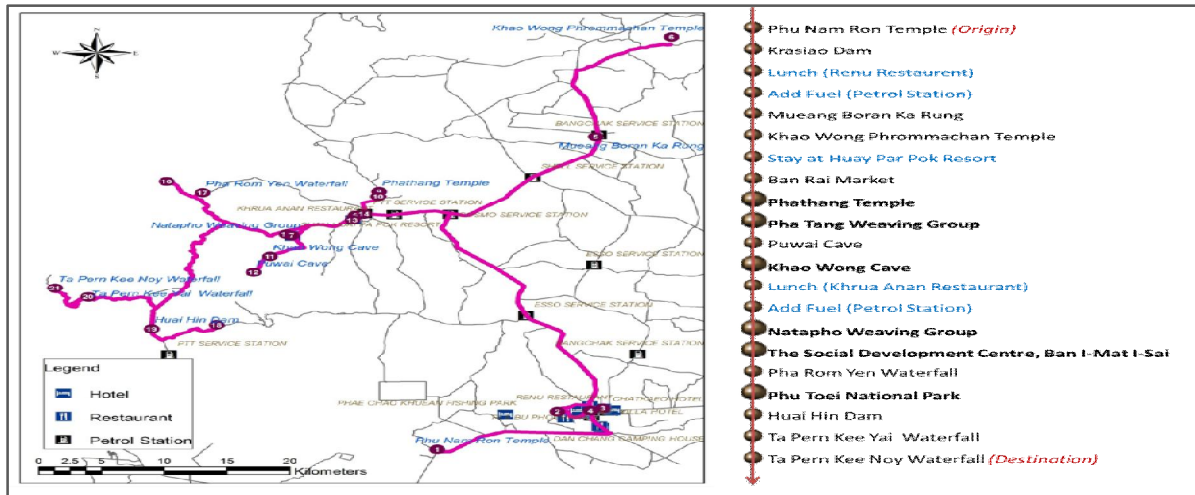


Figure 8. Map illustrating the complete three-day route trip for tourists

<b>Day 1</b>	
- 8:00 - 11:00	Drive from Bangkok
- 11:00 - 11:45	Phu Nam Ron Temple
- 11:03 - 12:48	Krasiao Dam
- 12:55 - 13:55	Lunch (Renu Restaurant)
- 13:57 - 14:07	Add Fuel at Petrol Station
- 14:44 - 15:29	Mueang Boran Ka Rung
- 15:42 - 16:27	Khao Wong Phrommachan Temple
- 17:05	Stay at Huay Par Pok Resort
<b>Day 2</b>	
- 7:05 - 8:05	(Breakfast) Ban Rai Market
- 8:10 - 8:55	Phathang Temple
- 8:56 - 10:26	Pha Tang Weaving Group
- 10:39 - 12:09	Khao Wong Cave
- 12:12 - 12:57	Puwai Cave
- 13:09 - 14:09	Lunch (Khrua Anan Restaurant)
- 14:10 - 14:20	Add Fuel at Petrol Station
- 14:26 - 15:56	Natapho Weaving Group
- 16:10 - 17:40	The Social Development Centre, Ban I-Mat I-Sai
- 17:48 - 18:33	Pha Rom Yen Waterfall
- 19:07	Phu Toei National Park
<b>Day 3</b>	
- 7:00 - 13:00	Phu Toei National Park
- 13:08 - 13:53	Huai Hin Dam
- 14:07 - 14:52	Ta Pern Kee Yai Waterfall
- 15:03 - 15:48	Ta Pern Kee Noy Waterfall

Figure 9. Three-day and two-nights tour package for Ban Rai and Dan Chang District

locations of hotels, restaurants, and petrol stations as well as the number of hours spent at each place. In the proposed programmes shown in Figure 9, the time being spent at high potential tourist attractions will be set as 90 minutes while time spent for low potential tourist attractions will be set as 45 minutes. The high potential places are as follows: Phathang Temple, Pha Tang Weaving Group, Khao Wong Cave, Natapho Weaving Group, The Social Development Centre Ban I-Mat I-Sai, and Phu Toei National Park. Such a plan can be adjusted to fulfill the tourist's requirements, e.g., different age groups, trip purposes. It is thus hoped that the simulation with the additional information can be adapted to other tourist regions to help promote tourism industry

## 6. Conclusion

This paper presents an alternative, the integration of geographical technology to economize planning trips. The study area was the connecting areas of Ban Rai district, UthaiThani province and Dan Chang district, SuphanBuri province. This area has a potential to attract tourists in the near future since it contains both cultural and natural tourist attractions. The technical approach in the study involves three key steps; the use of GPS to collect data, development of GIS database and network datasets, and simulation of routes in network analysis. For the simulation, the "exact route" and "hierarchical route" algorithm as well as the number of days spent were applied. Results of the study were route maps with different alternatives. The study also proved that the GIS-based network analysis is considerably useful for tourism applications and route planning trips. Limitations of this research are mainly the lack of information on tourist attraction potential, and other business locations in the study site such as hotels, restaurants, shopping places, and petrol stations. If this information is provided, it will help improve the travelling plans to be realistic and can be adapted to other areas.

## 7. Acknowledgements

This paper is a part of the project entitled "Geographical Techniques for the Study of Cultural Diversity and Tourism Development" under the "Project on Language and Human Security in Thailand, within the Integrated Academic Innovation Initiative, Chulalongkorn University's Academic Development Plan (CU Centenary)". The authors wish to thank Faculty of Arts and Chulalongkorn

University's Academic Development Plan (CU Centenary) for the financial support that made this study possible. Without their support this study would not have been completed.

## 8. References

- [1] World Travel and Tourism Council (WTTC), "Travel and Tourism Economic Impact 2012: Thailand", Retrieved 2 November, 2012 from [http://www.wttc.org/site\\_media/uploads/downloads/hathail2012.pdf](http://www.wttc.org/site_media/uploads/downloads/hathail2012.pdf), 2012, pp.1-18.
- [2] Ministry of Tourism and Sports (MOTS), "Tourism Development Plan 2012-2016", Retrieved 30 December, 2012 from <http://marketingdatabase.tat.or.th/download/article/NatiNatiNationalTourismDev2555-2559.pdf>
- [3] P. A. Longley, M. F. Goodchild, D. J. Maguire, and D. W. Rhind, *Geographic information systems and science*, Wiley, New York, 2005.
- [4] A.T. Murray, "Quantitative Geography". *Journal of Regional Science*, Wiley Periodicals, 50(1), 2010, pp. 143-163.
- [5] C.M., Hall and S.J. Page, "Progress in Tourism Management: From the geography of tourism to geographies of tourism—A review", *Tourism Management*, 30(1), 2009, pp. 3-16.
- [6] C. Durán, "Geographic Information Systems: use cases for tourism analysis in local areas" *EnzoPaci Papers, World Tourism Organization*, 2009, pp. 129-148.
- [7] M.A. Al Qeed, I.K. Bazazo, A.I. Hasonah and B.A. Al Qaid, "Using Geographic Information System to Visualize Travel Patterns and Market Potentials of Petra City in Jordan", *International Journal of Marketing Studies*, Canadian Center of Science and Education, 2(2), 2010, pp. 144-159.
- [8] A.G. Othaman, B. Mohamed, A. Bahaudin, A.P. Mat Som, and S.I. Omar, "A Geographic Information System Based Approach for Mapping Tourist Accommodation in the East Coast States of Malaysia", *World Applied Sciences Journal*, 10, 2010, pp. 14-23.
- [9] A.S. Dye and S.L. Shaw, "A GIS-based spatial decision support system for tourists of Great Smoky

Mountains National Park”, *Journal of Retailing and Consumers Services*, 14, 2007, pp. 269-278.

[10] K. Pornprasertchai, “Application of remote sensing and GIS for tourist map production of Phuket”, *Paper presented at the 22nd Asian Conference on Remote Sensing*, Singapore, 2001

[11] T. Bahaire, and M. Elliott-White, “The application of geographical information systems (GIS) in sustainable tourism planning: A review”, *Journal of Sustainable Tourism*, 7(2), 1999, 159-174.

[12] W. G. van der Knaap, “Research report: GIS-oriented analysis of tourist time-space patterns to support sustainable tourism development”, *Tourism Geographies*, 1(1), 1999, 56-69.

[13] T. Turk, and M. U. Gumusay, “GIS design and application for tourism”, *XXth ISPRS Congress*, 2004, pp. 12-23.

[14] M. Pietsch, E. Buhmann, N. AnddysAnd D. Önal, “Using Network Analysis-GIS in Landscape Planning Case Study: Valetta and Floriana, Republic of Malta” *Arte-Polis 3 International Conference*, 2006, pp.551-555.

[15] H.Y. Shih, “Network characteristics of drive tourism destinations: An application of network analysis in tourism”, *Tourism Management*, 27(5), 2006, pp. 1029-1039.

[16] C.R. Chiou, W.L. Tsai, and Y.F. Leung, “A GIS-dynamic segmentation approach to planning travel routes on forest trail networks in Central Taiwan”, *Landscape and Urban Planning*, 97(4), 2010, pp. 221-228.

[17] S.H. Lee, J.Y. Choi, S.W. Yoo, and Y.G. Oh, “Evaluating spatial centrality for integrated tourism management in rural areas using GIS and network analysis”, *Tourism Management*, 34, 2012. pp. 14-24.

[18] N. Pongsri, *A Geographic Information System for eco-tourism in ChangwatSamutSokkhrum*, Chulalongkorn University, 2007

[19] J.F. Hallo, J.A. Beeco, C. Goetcheus, J. McGee, N.G. McGehee and W.C. Norman, “GPS as a method for assessing spatial and temporal use distributions of nature-based tourists”, *Journal of Travel Research*, 51(5), 2012, pp. 591-606.

[20] O. Eriksson, and L. Åkerblom, “Tourism Information Systems based on Trail Network Information”, *In Information and communication technologies in tourism 2003: Proceedings of the International Conference in Helsinki, Finland*, 2003, pp. 448-457.

[21] Institute for Road Safety Research, “Speed choice: the influence of man, vehicle, and road”, Retrieved 24 December, 2012 from [http://www.swov.nl/rapport/Factsheets/UK/FS\\_Speed\\_choice.pdf](http://www.swov.nl/rapport/Factsheets/UK/FS_Speed_choice.pdf), pp.1-6.

[22] J. Edquist, C. Rudin-Brown, and M. G. Lenne, *Road design factors and their interactions with speed and speed limits*, Monash University Accident Research Centre, 2009.

[23] A. Patnukao, and S. Teerarojanarat, “The Potential of Tourist Attractions: a Case Study of 2 Rural Connecting Districts in the Western Part of Thailand”, *In Proceeding of the Asian Conference on Sustainability, Energy and the Environment*, 2013.



# Stakeholder Analysis in Selected Tourism Destinations

Martin Luštický, Pavla Zaubmüllerová, Lenka Havlová

*University of Economics, Prague, Faculty of Management*  
[Lusticky@fm.vse.cz](mailto:Lusticky@fm.vse.cz) [xzaupt00@fm.vse.cz](mailto:xzaupt00@fm.vse.cz), [zhavl8@fm.vse.cz](mailto:zhavl8@fm.vse.cz)

## Abstract

*This paper is focused on the process of stakeholder analysis in selected tourism destinations in the Czech Republic. Its aim is to map and analyse key regional stakeholders in travel & tourism sector by the means of the Stakeholder Circle method and combination of quantitative and qualitative data gathering techniques. It analyses three attributes of regional stakeholders, forms of their involvement into the process of tourism development planning and their experience with this process. On this basis the paper discusses the possibilities for transfer of good practices from British destinations. These practices can enhance a quality of implementation process of regional tourism development strategies, and thus improve a competitive position of the Czech tourism destinations on tourism market.*

## 1. Introduction

One of the areas the recent regional policy is focused on is a support of tourism development that can be considered a specific tool of regional development [1]. Tourism contributes to both regional and local economy stability, especially because of its positive multiplier effect. The benefits of tourism can be characterised as positive outcomes of the processes in a territory that have influence on development of the new possibilities for local inhabitants, increase utilities of local economy and decline some negative phenomena [2]. Tourism has multidimensional character and so it intervenes in many economic branches. It has also a positive effect even in social and ecological spheres [3], [4].

Tourism as well as other economic branches faces the competitive pressures which grow significantly in recent global society [5]. This is why the European Union, national and regional governments try to find ways aimed at increase in competitiveness in tourism. One of the widely recognized factors of a

competitiveness is strategic management and strategic planning [5], [6], and [7].

This paper emphasises the importance of stakeholder involvement into the process of strategic planning in tourism destination. It is focused on stakeholder analysis by the means of the Stakeholder Circle method. This method enables to map the regional stakeholders, meet their characteristics and it also enables to suggest the appropriate strategy for mutual cooperation during the planning process.

## 2. Stakeholder Involvement in Strategic Planning in Tourism Destination

Tourism destination must be managed responsibly to be able to fully utilize all the positive impacts of tourism [8]. The process of strategic planning should significantly help to this task. Edgell defines the strategic tourism planning as “a process aimed to optimize the benefits of tourism so that the result is a balance of the appropriate quality and quantity of supply with the proper level of demand, without compromising neither the locale’s socioeconomic and environmental development, nor its sustainability” [9: 297]. Thus, the main objective of strategic planning is to maximize the benefits of tourism for local inhabitants thanks to an improvement of tourism destination competitive position [3].

Strategic planning process can be decomposed to these phases: (a) defining of basic presumptions; (b) external and internal analysis; (c) setting of strategic targets; (d) selection of appropriate strategy and (e) implementation of the strategy. The phases (a) – (d) are very well described in the literature – e.g. [3], [4], [5], and [10]. The implementation process is not examined in such a detailed way. Nevertheless, both realization and subsequent monitoring are crucial for success of a strategy as a whole; without them the entire process loses its purpose [11].

An involvement of the most important regional stakeholders is an inevitable condition for successful implementation of the strategy, which is emphasized by a number of authors – e.g. [3], [5], [12]. An involvement of regional stakeholders is also one of the main principles for achieving a sustainable

tourism development and long-term competitive advantage [8], [13].

Buhalis points out that managing of tourism with an involvement of the regional stakeholders is extremely difficult for a destination management. Quite a number of stakeholders groups with various interests, complex mutual relations and different willingness to cooperate in implementation of the strategy occur in a given destination [12]. Destination stakeholders can be widely defined as such organizations which are affected by the management of destination or which are able to affect its success. The typical stakeholders in a destination are represented by local inhabitants, regional and local government, entrepreneurs, tourist associations, development agencies [12], [14], [15].

The complexity of tourism destination environment emphasises the importance of the coordination role of destination management within the implementation process of tourism development strategy. So, the necessary first step rests in an identification of the key regional stakeholders, to which an attention of the destination management must be paid and which concerns must be satisfied [13], [16].

### 3. Research Methodology

Stakeholder analysis can be carried out by a number of methods for mapping and evaluation of the stakeholders, as summarized for instance by [16], [17]. Most of the methods use graphical representation in the form of maps of the regional stakeholders according to their attributes.

The presented research uses the Stakeholder Circle method which is modified for the conditions of stakeholder analysis in tourism destinations. It examines the attributes of stakeholders and identifies the most important stakeholders in particular destination. The next phase of the research is focused on an ascertainment of key stakeholders' satisfaction with an involvement in implementation process of tourism development strategies. The intention of this survey is to specify the opportunities for a quality enhancement. After that it will be possible to react to those improvement opportunities by a transfer of good practices from tourism destinations in Great Britain. The above mentioned framework of the research is illustrated in the following figure.



**Figure 1. Research methodology**

In the first step it is necessary to identify the basic groups of destination stakeholders. This research considers as the stakeholders such organizations which operate in region influencing by the strategy, and which participated in strategy elaboration, or which are affected by this strategy. Using the approach of [8], [12], [14] the following groups of stakeholders are compiled: regional government, micro-regions, municipalities, tourism organizations, destination management organizations (DMO), and regional development agencies.

The Stakeholders Circle method employs these attributes for characterizing of the stakeholders: stakeholder influence on the project, involvement of the stakeholder in the project and the urgency of the stakeholder [18]. With regard to the specifics of tourism these characteristics were modified to this set of attributes:

1. Importance (I) – the importance of the stakeholder for tourism development
2. Proximity (P) – the intensity of cooperation with the stakeholder in tourism development
  - Legitimacy (L) – the formality of cooperation with the stakeholder
3. Urgency (U) – the need of the stakeholder involvement in the strategy implementation process; decomposition into two subordinate attributes
  - Support (S) – share of the stakeholder in the strategy implementation process
  - Willingness (W) – interest of the stakeholder in an improvement of cooperation

The attribute of urgency is calculated according to the following formula:

$$U = \frac{S \times W}{16} \times 4 \quad (1)$$

On the basis of the Stakeholder Circle methodology the qualitative scale is defined for each attribute. This scale is expressed numerically in the range of 1-4 points. The logic of this scale is simple – an intensity of the attribute increases with increasing number of points. The necessary information is

obtained through structured interviews with the representatives of regional government.

The output of this method is a graphical representation of stakeholders groups in the form of circular sectors. The Stakeholder Circle methodology was simplified in such a way that it is possible to construct the graph manually, without the necessity of specialized software.

In addition to the graphical representation, it is possible to compute the Stakeholder Index by the following formula:

$$SI = \sum(I, P, U) \quad (2)$$

This index allows ranking the stakeholders groups with respect to the importance based on selected attributes. Thus it indicates those regional stakeholders the regional government should focus on within implementation of the strategy.

The next phase of the research is targeted on particular representatives of given key stakeholders groups. Its aim is to gather information about weaknesses and strengths of the current cooperation process from stakeholders' points of view. The survey is realized in a form of structured interviews. It provides information about the state of cooperation with regional government and enables us to identify the improvement opportunities.

The last phase of our research will use ascertained good practices from selected British tourism destinations. These practices should serve as a tool for an improvement of the cooperation process between regional stakeholders in a realization and control of the Czech regional tourism development strategies.

#### 4. Stakeholder Analysis

The aim of the current testing phase of our research is to verify the drafted methodology in two Czech tourism destinations – self-governing regions.

The South Bohemia Region belongs among the most visited tourism destinations in the Czech Republic. It is a traditional place for vacation of domestic and foreign visitors. The South Bohemia Region has excellent conditions for tourism development which rise from well-preserved nature, a number of cultural and historical monuments and high-quality tourist infrastructure for active or family holiday.

The Usti nad Labem Region does not belong to typical Czech tourism destinations. Nevertheless tourism plays an important role in local economy in this region. This region is a popular destination for visitors from Prague and its surroundings and also from Germany and Poland. The region has very good conditions for hiking, cycling and skiing due to its mountain area.

#### 4.1. Stakeholder Analysis Results

Stakeholder mapping by the means of the Stakeholder Circle methodology was made with the help of three key attributes: importance, proximity and urgency.

The representatives of regional government evaluated those attributes on 1 – 4 point scale which was used for each group of stakeholders.

The attribute of urgency was quantified according to the formula nr. 1. The attribute of legitimacy is considered as an additional statement of the attribute of proximity and it is marked by the grey hatching.

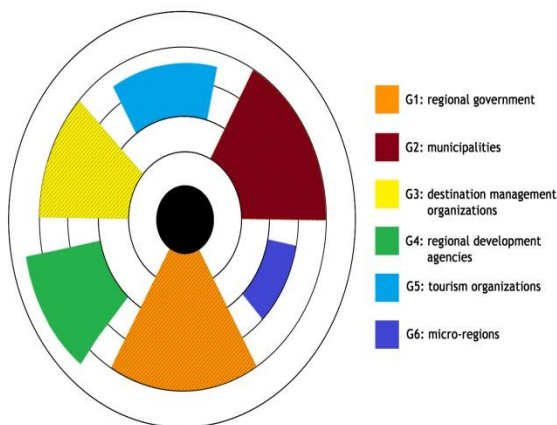
The value of the Stakeholder Index was quantified according to the formula nr. 2.

The results of stakeholder mapping are described in the following table nr. 1 (SI = Stakeholder Index; I = attribute of importance; P = attribute of proximity; U = attribute of urgency).

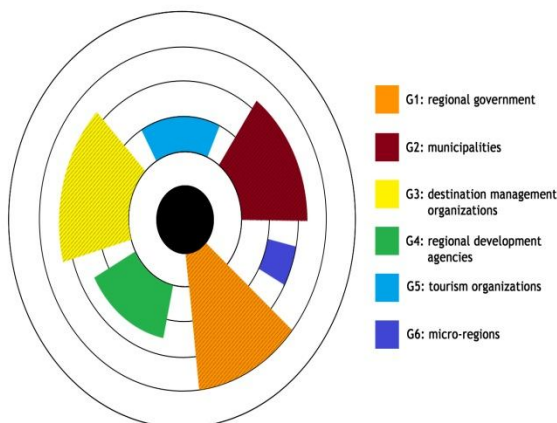
**Table 1. Stakeholders' attributes**

Groups of Stakeholders	Stakeholders' Attributes			S
	I	P	U	
<b>South Bohemia Region</b>				
Regional Government	4 ,0	4 ,0	4 ,0	1 2,0
Municipalities	4 ,0	3 ,0	3 ,0	1 0,0
DMO	3 ,0	3 ,0	3 ,0	9 ,0
Development Agencies	3 ,0	2 ,0	2 ,3	7 ,25
Tourism Organizations	3 ,0	2 ,0	1 ,5	6 ,5
Micro-regions	2 ,0	2 ,0	1 ,0	5 ,0
<b>Usti nad Labem Region</b>				
Regional Government	3 ,0	4 ,0	4 ,0	1 1,0
Municipalities	4 ,0	3 ,0	2 ,3	9 ,25
DMO	3 ,0	3 ,0	2 ,3	8 ,25
Development Agencies	3 ,0	3 ,0	1 ,5	7 ,5
Tourism Organizations	3 ,0	3 ,0	1 ,0	7 ,0
Micro-regions	1 ,0	2 ,0	1 ,0	4 ,0

The described findings can be illustrated by the Stakeholder Circle. The attribute of importance is represented by size of the sector, attribute of proximity is represented by distance of the sector from centre of the circle, and the attribute of urgency is represented by depth of the sector. The attribute of legitimacy is marked by hatching of the sector.



**Figure 2. SC – the South Bohemia Region**



**Figure 3. SC – the Usti nad Labem Region**

The results of stakeholder mapping are very similar in both regions. The dominant role has a regional government which is represented by the departments of the regional office – especially the department for tourism development. The South Bohemia Tourism Authority serves as a central destination management organization, based for more efficient coordination and management of tourism in the South Bohemia Region. The activities of regional government are focused on the creation of general conditions for tourism development – e.g. in the form of administration of the regional grant programmes, propagation of the region, coordination and propagation of tourism products, cooperation with other subjects and information exchange.

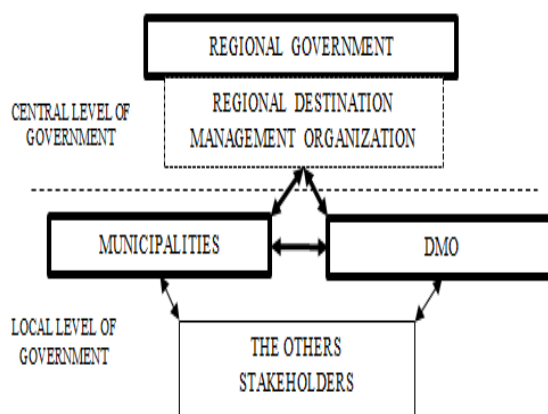
The former district towns and destination management organizations (DMO) can be considered as the most important stakeholders participating on tourism development. The cooperation can be considered very intensive, based on the strong long-term ties and regular meetings. The cooperation with other regional stakeholders is not so intensive. It is limited to concrete activities which are related to a support of tourism development.

From the point of view of the strategic priorities achievement, the municipalities provide information about potential recipients of financial support and they also serve as the administrators of the regional grant programmes. They participate in marketing activities in tourism and give a feedback about their efficiency. The municipalities also support and initiate a formation of the new tourism products to some extent – e.g. in the form of participation in trade fairs, creation of product packages, advertising materials and sharing of good practices.

The very important partners for coordination of tourism development are the destination management organizations. They are in close relationship with the municipalities and other stakeholders.

Within the strategy implementation process they provide valuable information about the development of tourism and visitors' satisfaction. They also take part in defining the scope of the programmes for tourism development. The destination management organizations actively participate in a formation and support process of the new tourism products – they cooperate in the field of marketing and promotion, administer the information systems, suggest new products and product packages, coordinate the suggestions and activity of private sector organizations. Simultaneously, they also gather information from entrepreneurs which serve as an informal feedback for evaluation of the success of the strategy implementation process.

The above mentioned facts concerning stakeholders' involvement into the process of collaboration on tourism development are described in the following figure nr. 4.



**Figure 4. Cooperation on tourism development**

#### 4.2. Assessment of Stakeholder Involvement in Strategy Implementation Process

The next phase of our research was focused on an assessment of intensity and quality of cooperation in realization and control of the tourism development strategy on regional level. The survey was performed in a form of structured interviews with the



representatives of former district towns (MUN) and destination management organizations (DMO). The evaluators used the point scale drafted in a same way as in the case of stakeholders' attributes.

The following table summarises main findings of the survey from the South Bohemia Region. A simple three-colour semaphore method is used in this table:

- red – an average evaluation belongs to the interval <0; 1>; it is a signal of the weak point (improvement opportunity)
- orange – an average evaluation belong to the interval (1; 3); it is a signal of the neutral point
- green – an average evaluation belong to the interval <3; 4>; it is a signal of the strong point

**Table 2. Assessment of the cooperation**

Content of the Survey			M UN	D MO
<b>Realization of the Strategic Priorities</b>				
P1: Tourism Infrastructure	ity	intens	Orange	Green
		qualit	Orange	Green
P2: Human Resources Development	ity	intens	Red	Green
		qualit	Red	Green
P3: Legislation Monitoring	ity	intens	Red	Green
		qualit	Red	Green
P4: Creation of Tourism Products	ity	intens	Green	Orange
		qualit	Green	Orange
<b>Control of the Strategic Priorities Performance</b>				
Control Activities	ity	intens	Red	Green
		qualit	Red	Green

The results of our survey indicate a significant role of the destination management organizations. Their cooperation with regional government has been running without any serious problems. None the less, the DMOs can be better involved in the process of definition of the key tourism products and their proposal. This priority sphere also embodies lower intensity of cooperation between regional government, DMOs and entrepreneurs in travel & tourism sector.

The cooperation with municipalities has been successfully evolving during formation process of the new tourism products; it has a form of formal and financial support. The situation is little bit worse in the sphere of tourism infrastructure improvement. The municipalities miss joint projects focused on

tourism infrastructure renewal and specific grant programmes. The municipalities make use of own programmes for human resources development, so the cooperation within this priority is not considered as inevitable. Common monitoring of legislation has not been realised on regular basis; the municipalities dispose this responsibility to regional government. The fundamental weak point of the cooperation can be found within a control process of the strategy which is entirely performed in a non-formal way during some meetings with representatives of regional government or within the framework of regular contacts with destination management organizations.

## 5. Conclusion

It is possible to claim that the testing phase of our research was successful. The drafted method of stakeholder analysis has proved its fitness for use in practice. It was possible to characterize all the stakeholders groups in selected destinations, assign the rank of stakeholders' importance and describe mutual links between regional government and key stakeholders groups. The ascertained information was used within the mapping of real situation in the sphere of cooperation during the process of tourism development strategy implementation in the South Bohemia Region. The output of this phase was an identification of the strong points and improvement opportunities (weak points) from the point of view of key stakeholders groups.

It should be possible to react on identified improvement opportunities by the means of knowledge transfer from British tourism destinations. The possibility of good practices transfer was tested in tourism destination of Wales. This destination was selected because of high-quality development strategy [19] and similarity of tourism management system.

It is possible to identify these spheres of potential good practices from preliminary results of the interviews with the Wales Destination Authority representatives: (a) quality of tourism infrastructure and services, (b) accessibility of tourism products, (c) education and human resources development, (d) partnership in tourism development, and (e) cooperation in controlling process (feedback from regional stakeholders).

The next phase of the research will analyse these spheres with the aim to disclose concrete good practices and suggest the right way for their transfer into conditions of the South Bohemia Region. In the same way, the research will be realised in other Czech tourism destinations. This scheme should lead to an improvement of cooperation process between stakeholders and thus to destinations' competitive position advancement.

## 6. References

- [1] N. Vanhove, *The Economics of Tourism Destinations*, Routledge, New York, 2011.
- [2] K. K. Sharma, *Tourism and Regional Development*, Sarup& Sons, New Delhi, 2004.
- [3] C. M. Hall, *Tourism Planning: Policies, Processes and Relationships*, Prentice Hall, Harlow, 2008.
- [4] Ch. Cooper et al., *Tourism: Principles and Practice*, Pearson Education, Harlow, 2008.
- [5] J. R. B. Ritchie, and G. I. Crouch, *The competitive destination: a sustainable tourism perspective*, CABI Publishing, Wallingford, 2003.
- [6] M. J. Enright, and J. Newton, "Determinants of Tourism Destination Competitiveness in Asia Pacific: Comprehensiveness and Universality", *Journal of Travel Research*, 2005, vol. 43, no. 4, pp. 339-350.
- [7] L. Dwyer, L., and C. Kim, "Destination Competitiveness: Determinants and Indicators", *Current Issues in Tourism*, 2003, vol. 6, no. 5, pp. 369-414.
- [8] E. T. Byrd, D. A. Cárdenas, and J. B. Greenwood, "Factors of stakeholder understanding of tourism: The case of Eastern North Carolina", *Tourism and Hospitality Research*, 2008, vol. 8, no. 3, pp. 192-204.
- [9] D. L. Edgell et al., *Tourism Policy and Planning. Yesterday, Today and Tomorrow*, Elsevier, Oxford, 2008.
- [10] F. R. David, *Strategic Management: Concepts and Cases*, Prentice Hall, New Jersey, 2009.
- [11] T. H. Poister, and G. D. Streib, "Strategic Management in the Public Sector: Concepts, Models, and Processes", *Public Productivity & Management Review*, 1999, vol. 22, no. 3, pp. 308-325.
- [12] D. Buhalis, "Marketing the competitive destination of the future", *Tourism Management*, 2000, vol. 21, no. 1, pp. 97-116.
- [13] Ch. Aas, A. Ladkin, and J. Fletcher, "Stakeholder Collaboration and Heritage Management", *Annals of Tourism Research*, 2005, vol. 32, no. 1, pp. 28-48.
- [14] Y. Yoon, *Development of a Structural Model for Tourism Destination Competitiveness from Stakeholders' Perspectives*, Virginia Polytechnic Institute and State University, 2002.
- [15] G. I. Crouch, "Destination Competitiveness: An Analysis of Determinant Attributes", *Journal of Travel Research*, 2010, vol. 20, no. 10, pp. 1-19.
- [16] L. Medeiros de Araujo, and B. Bramwell, "Stakeholder Assessment and Collaborative Tourism Planning: The Case of Brazil's Costa Dourada Project", *Journal of Sustainable Tourism*, 1999, vol. 7, no. 3-4, pp. 356-378.
- [17] J. M. Bryson, "What to do when Stakeholders matter: Stakeholder Identification and Analysis Techniques", *Public Management Review*, 2004, vol. 6, no. 1, pp. 21-53.
- [18] D. Walker, A. Shelley, and L. Bourne, "Influence, Stakeholder Mapping and Visualisation", *Construction Management and Economics*, 2008, vol. 26, no. 6, pp. 645-658.
- [19] M. Luštický, and T. Kincl, "Tourism Destination Benchmarking: Evaluation and Selection of the Benchmarking Partners", *Journal of Competitiveness*, 2012, vol. 4, no. 1, pp. 99-116.

# Quantile Hedging in Diffusion (B, S) – Market for European Call Option

Daniliuc Elena

*Institute of Physics and Technology, Tomsk Polytechnic University, Tomsk, Russia*  
[daniluc\\_elena@sibmail.com](mailto:daniluc_elena@sibmail.com)

Rozhkova Svetlana

*Institute of Physics and Technology, Tomsk Polytechnic University, Tomsk, Russia*<sup>2</sup>  
[rozhkova@tpu.ru](mailto:rozhkova@tpu.ru)

## Abstract

*The problem of an option is considered. Investigation of portfolio (hedging strategy) and capital evolution out time providing the payment obligation with set probability is conducted for European call option when dividends on risk active are paid. Specific properties of decision are investigated.*

## 1. Introduction

An option is a derivative (secondary) security, i.e. the contract giving option buyer (the holder) the right to purchase or sell stipulated underlying asset by a certain date for a certain price, and option seller must satisfy an agreement when exercising for an option premium [1]. In the first case it is call option, and in the second one – put option. Standard call option with payoff function is  $f_T = (S_T - K)^+ = \max(0, S_T - K)$ , where  $S_T$  - spot price at expiration date  $T$ ;  $K$  - exercise price or strike price that can be exercised only on the maturity called European call option. When probability of exercising equals 1 (perfect hedging or super hedging), option payments can be sufficiently high, and this situation represents substantial risk for the emitter (investor) and, in its turn, limits this risk. In the following investigation this problem is solved by quantile hedging, where probability of exercising is less than 1 [2].

We denote the mathematical expectation  $E\{\cdot\}$ , normal (Gaussian) density with parameters  $a$  and  $b$  by  $N\{a; b\}$  as

$$\Phi(x) = \int_{-\infty}^x \varphi(y) dy, \quad \varphi(y) = \frac{1}{\sqrt{2\pi}} \exp\left\{-\frac{y^2}{2}\right\}$$

where,  $\Phi^{-1}(y)$  is inverse Laplace distribution function.

## 2. Statement of the problem

Even though it is stochastic,  $(\Omega, F, \mathbf{F} = (F_t)_{t>0}, \mathbf{P})$  is the problem [3], [4]. Risk and risk free assets, circulating in a financial market, have current prices as

$$S_t = S_0 \exp\left\{\left(\mu - \frac{\sigma^2}{2}\right)t + \sigma W_t\right\}, \quad B_t = B_0 \exp\{rt\} \quad (2.1)$$

During time interval  $t \in [0, T]$ , where,  $W = (W_t)_{t \geq 0}$  is standard Wiener process  $\mu \in R = (-\infty, +\infty)$ ,  $\sigma > 0$ ,  $r > 0$ ,  $S_0 > 0$ ,  $B_0 > 0$ .

Equations in (2.1) are the solution of equals

$$dS_t = S_t(\mu dt + \sigma dW_t), \quad dB_t = rB_t dt. \quad (2.2)$$

Let us consider the current value of investor capital  $X_t$  defined as  $X_t = \beta_t B_t + \gamma_t S_t$ , where  $\pi_t = (\beta_t, \gamma_t)$  is an investment portfolio consisting of two  $F_t$  - measurable process. Holding asset dividends are paid in accordance to process  $D_t$  at the rate of  $dD_t = \delta \gamma_t S_t dt$ ,  $\delta > 0$ .

The problem involves the fact that to form the portfolio (hedging strategy)  $\pi_t^* = (\beta_t^*, \gamma_t^*)$ , the evolution of the capital  $X_t^*$  has option price  $C_T = X_0^*$  in accordance to the payoff function (1.1) or (1.2), as well as, the hedging strategy and corresponding capital, ensuring the fulfillment of payment liability

$$X_T^* = f_T(S_T) \quad (2.3)$$

where, set probability  $\mathbf{P}(A) = 1 - \varepsilon$ ,  $0 < \varepsilon < 1$ .



### 3. Preliminary results

*Proposition 1* [3], [4]. Let us consider that risk-neutral (martingale) measure  $\mathbf{P}^* = \mathbf{P}^{\mu-r+\delta}$  is associated with source measure  $\mathbf{P}$  by transformation, then

$$d\mathbf{P}_t^{\mu-r+\delta} = Z_t^{\mu-r+\delta} d\mathbf{P}_t, \quad (3.1)$$

where,

$$Z_t^{\mu-r+\delta} = \exp\left\{-\left(\frac{\mu-r+\delta}{\sigma}\right)W_t - \left(\frac{\mu-r+\delta}{\sigma}\right)^2 t/2\right\} \quad (3.2)$$

Thus, stochastic properties of the process  $S(\mu, r, \delta)$  are defined by the equation

$$dS_t(\mu, r, \delta) = S_t(\mu, r, \delta)\left((r-\delta)dt + \sigma dW_t^{\mu-r+\delta}\right). \quad (3.3)$$

In this case,  $\mathbf{P}^{\mu-r+\delta}$  coincides with properties of the process  $S(r, \delta)$  and are defined by the following equation

$$dS_t(r, \delta) = S_t(r, \delta)\left((r-\delta)dt + \sigma dW_t\right) \quad (3.4)$$

while,  $\mathbf{P}$  is a measure, where

$$W_t^{\mu-r+\delta} = W_t^* = W_t + \frac{(\mu-r+\delta)}{\sigma}t \quad (3.5)$$

is Wiener process in reference to  $\mathbf{P}^{\mu-r+\delta} = \mathbf{P}^*$ .

Perfect hedging set.

According to Theorem 6.1 described by A. Melnikov [5], the optimal strategy in quantile hedging problem coincides with perfect hedge of payment liability (probability equals 1)  $f_T^\varepsilon = f_T I_A$  where,  $I_A$  is the indicator of set  $A$

$$A = \left\{ \omega : \frac{d\mathbf{P}}{d\mathbf{P}^*} > \text{const} \cdot f_T \right\}. \quad (3.6)$$

Equations (2.1), (3.1) – (3.5) and call option payment function, as well as, range of perfect hedging  $A$  is assumed as

$$A = \left\{ S_T \frac{\mu-r+\delta}{\sigma^2} \exp\left\{-\frac{\mu-r+\delta}{\sigma^2}(\ln S_0 + \frac{\mu+r+\delta-\sigma^2}{2}T)\right\} > \text{const} \cdot (S_T - K)^+ \right\} \quad (3.7)$$

if,

$$\left[ \frac{(\mu-r+\delta)}{\sigma^2} \right] > 1. \quad (3.8)$$

Crosshatched region shown in Fig. 1 is solution area of inequality (3.7) where,

$$\varphi_1(S_T) = \text{const}(S_T - K)^+, \quad \varphi_2(S_T) = S_T^{(\mu-r+\delta)/\sigma^2}.$$

To arrive at this equation, we used (2.1), (2.2) and (3.3) – (3.5)

$$S_T = S_0 \exp\left\{\left(r+\delta - \left(\frac{\sigma^2}{2}\right)\right)T + \sigma W_T^*\right\}. \quad (3.9)$$

Recalling that set  $A$  can be written as

$$A = \{S_T < d_1\} \cup \{S_T > d_2\} = \{W_T^* < b_1\} \cup \{W_T^* > b_2\}. \quad (3.10)$$

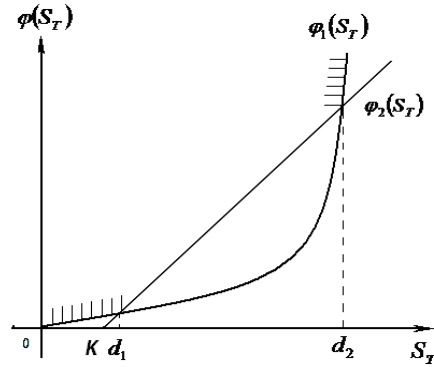


Fig.1. Hedging set structure -  $\left[ \frac{(\mu-r+\delta)}{\sigma^2} \right] > 1$ .

Then,

$$\mathbf{P}(A) = \mathbf{P}\left\{S_T < S_0 \exp\left\{\left(r-\delta - \left(\frac{\sigma^2}{2}\right)\right)T + b_1 \sigma\right\}\right\} + \mathbf{P}\left\{S_T > S_0 \exp\left\{\left(r-\delta - \left(\frac{\sigma^2}{2}\right)\right)T + b_2 \sigma\right\}\right\}, \quad (3.11)$$

It follows from (3.9) that

$$\mathbf{P}(A) = \mathbf{P}\left\{W_T < b_2 - \left[\frac{\mu-r+\delta}{\sigma}\right]T\right\} + \mathbf{P}\left\{W_T > b_2 - \left[\frac{\mu-r+\delta}{\sigma}\right]T\right\}. \quad (3.12)$$

Thus, we obtain

$$\mathbf{P}(A) = \Phi\left(\frac{b_1 - \left[\frac{\mu-r+\delta}{\sigma}\right]T}{\sqrt{T}}\right) + \Phi\left(\frac{-b_2 + \left[\frac{\mu-r+\delta}{\sigma}\right]T}{\sqrt{T}}\right), \quad (3.13)$$

where,  $\mathbf{P}(A) = 1 - \varepsilon$ ,  $0 < \varepsilon < 1$  is perfect hedging probability. Consequently, constants  $b_1 = b_1^T$ ,  $b_2 = b_2^T$  should satisfy the condition (3.13), but they are not precisely and clearly expressed.

#### 4. Main results

*Theorem 1* Let us consider,

$$y_0(T, S_0) = \left[ \ln\left(\frac{K}{S_0}\right) - \left(r - \delta - \frac{\sigma^2}{2}\right)T \right] / \left[ \sigma\sqrt{T} \right]. \quad (4.1)$$

Then, call option price cost at  $[(\mu - r + \delta)/\sigma^2] > 1$  is defined as

$$\begin{aligned} C_T = & S_0 e^{-\delta T} \left[ \Phi\left(\left(\frac{b_1^T}{\sqrt{T}}\right) - \sigma\sqrt{T}\right) \right. \\ & - \Phi(y_0(T, S_0) - \sigma\sqrt{T}) + \Phi\left(-\left(\frac{b_2^T}{\sqrt{T}}\right) + \sigma\sqrt{T}\right) \left. \right] \\ & - K e^{-rT} \left[ \Phi\left(\frac{b_1^T}{\sqrt{T}}\right) - \Phi(y_0(T, S_0)) + \Phi\left(-\frac{b_2^T}{\sqrt{T}}\right) \right]. \end{aligned} \quad (4.2)$$

*Proof* Accordingly [3]-[5], we obtain

$$C_T = e^{-rT} E^* \{ f_T I_A \} \quad (4.3)$$

where,  $E^*$  is martingale measure  $\mathbf{P}^*$  averaging. Based on equations (2.1), (3.1) and (4.1), we have

$$\begin{aligned} C_T = & e^{-rT} \int_{-\infty}^{\infty} \exp\left\{-\left((\mu - r + \delta)/\sigma\right)x\sqrt{T}\right. \\ & \left. - \left[T\left((\mu - r + \delta)/\sigma\right)^2/2\right]\right\} \times \left(S_0 \exp\left\{\left(r - \delta - \left(\sigma^2/2\right)\right)T\right\} \right. \\ & \left. + \sigma\sqrt{T}\left(x + \left((\mu - r + \delta)/\sigma\right)\sqrt{T}\right) - K\right)^+ \times I_A \cdot \varphi(x) dx. \end{aligned}$$

Substituting variables  $z = x + [(\mu - r + \delta)/\sigma]\sqrt{T}$  from (4.1) - (4.3) into

$$S_0 \exp\left\{\left(r - \delta - \left(\sigma^2/2\right)\right)T + \sigma\sqrt{T}z\right\} - K > 0$$

we get

$$\begin{aligned} C_T = & \left(e^{-rT}/\sqrt{2\pi}\right) \int_{-\infty}^{b_1^T/\sqrt{T}} \exp\left\{-z^2/2\right\} \times \\ & \times \left(S_0 \exp\left\{\left(r - \delta - \left(\sigma^2/2\right)\right)T + \sigma\sqrt{T}z\right\} - K\right)^+ dz \\ & + \left(e^{-rT}/\sqrt{2\pi}\right) \int_{b_2^T/\sqrt{T}}^{+\infty} \exp\left\{-z^2/2\right\} \\ & \times \left(S_0 \exp\left\{\left(r - \delta - \left(\sigma^2/2\right)\right)T + \sigma\sqrt{T}z\right\} - K\right)^+ dz \\ & = C_1 + C_2. \end{aligned} \quad (4.4)$$

So,  $C_1$  and  $C_2$  are defined by the equations

$$\begin{aligned} C_1 = & S_0 e^{-\delta T} \\ & \times \left[ \Phi\left(\left(b_1^T/\sqrt{T}\right) - \sigma\sqrt{T}\right) - \Phi(y_0(T, S_0) - \sigma\sqrt{T}) \right] \\ & - K e^{-rT} \left[ \Phi\left(b_1^T/\sqrt{T}\right) - \Phi(y_0(T, S_0)) \right] \end{aligned} \quad (4.5)$$

$$\begin{aligned} C_2 = & S_0 e^{-\delta T} \left[ \Phi\left(-\left(b_2^T/\sqrt{T}\right) + \sigma\sqrt{T}\right) \right] \\ & - K e^{-rT} \Phi\left(-b_2^T/\sqrt{T}\right) \end{aligned} \quad (4.6)$$

Then, we have (4.2), if we substitute (4.5) and (4.6) into (4.4).

*Theorem 2* In terms of (3.8) capital  $X_t^*$  and hedging strategy  $\pi_t^* = (\beta_t^*, \gamma_t^*)$  are defined by the equations

$$\begin{aligned} X_t^* = & S_t e^{-\delta(T-t)} \left[ \Phi\left(\left(b_1^{T-t}/\sqrt{T-t}\right) - \sigma\sqrt{T-t}\right) \right. \\ & + \Phi\left(-\left(b_2^{T-t}/\sqrt{T-t}\right) + \sigma\sqrt{T-t}\right) \\ & - \Phi(y_0(T-t, S_t) - \sigma\sqrt{T-t}) \left. \right] \\ & - K e^{-r(T-t)} \left[ \Phi\left(b_1^{T-t}/\sqrt{T-t}\right) \right. \\ & \left. + \Phi\left(-b_2^{T-t}/\sqrt{T-t}\right) - \Phi(y_0(T-t, S_t)) \right] \end{aligned} \quad (4.7)$$

$$\begin{aligned} \gamma_t^* = & e^{-\delta(T-t)} \left[ \Phi\left(\left(b_1^{T-t}/\sqrt{T-t}\right) - \sigma\sqrt{T-t}\right) \right. \\ & + \Phi\left(-\left(b_2^{T-t}/\sqrt{T-t}\right) + \sigma\sqrt{T-t}\right) \\ & - \Phi(y_0(T-t, S_t) - \sigma\sqrt{T-t}) \left. \right] \end{aligned} \quad (4.8)$$

$$\begin{aligned} \beta_t^* = & -e^{-r(T-t)} \frac{K}{B_t} \left[ \Phi\left(\left(b_1^{T-t}/\sqrt{T-t}\right) \right) \right. \\ & \left. + \Phi\left(-\left(b_2^{T-t}/\sqrt{T-t}\right) - \Phi(y_0(T-t, S_t)) \right] \end{aligned} \quad (4.9)$$

where,  $b_1^{T-t}$ ,  $b_2^{T-t}$ ,  $y_0(T-t, S_t)$  are defined by equations (3.13) and (4.1) with substitutions  $T \rightarrow (T-t)$ ,  $S_0 \rightarrow S_t$ .

*Proof* Accordingly [3]-[5], we obtain

$$X_t^* = E^* \left\{ e^{-r(T-t)} f_T I_A | S_t \right\}, \quad (4.10)$$

$$\gamma_t^* = \frac{\partial X_t^*(s)}{\partial s} \Big|_{s=S_t}, \quad \beta_t^* = \frac{X_t^* - \gamma_t^* S_t}{B_t}. \quad (4.11)$$

Hence, equation (4.7) is from (4.2) and (4.3) with replacements  $T \rightarrow (T-t)$ ,  $S_0 \rightarrow S_t$ . According to (4.7) and (4.11), we obtain

$$\begin{aligned} \gamma_t^* = & e^{-\delta(T-t)} \left[ \Phi\left(\left(b_1^{T-t}/\sqrt{T-t}\right) - \sigma\sqrt{T-t}\right) \right. \\ & + \Phi\left(-\left(b_2^{T-t}/\sqrt{T-t}\right) + \sigma\sqrt{T-t}\right) \\ & - \Phi(y_0(T-t, S_t) - \sigma\sqrt{T-t}) \left. \right] \\ & + K e^{-r(T-t)} \left( \partial \Phi(y_0(T-t, S_t)) / \partial S_t \right) - \\ & - S_t e^{-\delta(T-t)} \left( \partial \Phi(y_0(T-t, S_t) - \sigma\sqrt{T-t}) / \partial S_t \right) \end{aligned} \quad (4.12)$$

In terms of function form  $y_0(T-t, S_t)$ , we have the expressions

$$\begin{aligned} & \frac{\partial}{\partial S_t} \Phi(y_0(T-t, S_t)) \\ = & -\frac{1}{S_t \sigma \sqrt{2\pi(T-t)}} \exp\left\{-\frac{(y_0(T-t, S_t))^2}{2}\right\}, \\ & \frac{\partial}{\partial S_t} \Phi(y_0(T-t, S_t) - \sigma\sqrt{T-t}) \\ = & -\frac{1}{S_t \sigma \sqrt{2\pi(T-t)}} \exp\left\{-\frac{(y_0(T-t, S_t) - \sigma\sqrt{T-t})^2}{2}\right\}, \\ & e^{-\delta(T-t)} \exp\left\{-\frac{\sigma^2(T-t)}{2} + y_0(T-t, S_t)\sigma\sqrt{T-t}\right\} \\ = & \frac{Ke^{-r(T-t)}}{S_t}. \end{aligned}$$

Using (4.12) we get (4.8). Equation (4.9) is the result of equations (4.7), (4.8) and (4.11).

*Remark.* Theorems 1, 2 show an exact solution to the quantile hedging call option problem for dividend payment according to (3.8). In this case the equation for these payments (4.2) could be expressed by the equation of Melnikov [5].

## 5. Properties

*Proposition 2* Problem decision for dividend payment is defined by the following standard call option equations

$$\begin{aligned} \tilde{C}_T = S_0 e^{-\delta T} & \Phi\left(\frac{(r-\delta+(\sigma^2/2))T - \ln(K/S_0)}{\sigma\sqrt{T}}\right) \\ & - Ke^{-rT} \Phi\left(\frac{(r-\delta-(\sigma^2/2))T - \ln(K/S_0)}{\sigma\sqrt{T}}\right), \end{aligned} \quad (5.1)$$

$$\tilde{\gamma}_t = e^{-\delta(T-t)} \Phi\left(\frac{\left(r-\delta+\frac{\sigma^2}{2}\right)(T-t) - \ln\left(\frac{K}{S_t}\right)}{\sigma\sqrt{T-t}}\right), \quad (5.2)$$

$$\begin{aligned} \tilde{\beta}_t = & -\left(e^{-r(T-t)}K/B_t\right) \\ & \times \Phi\left(\frac{(r-\delta-(\sigma^2/2))(T-t) - \ln(K/S_t)}{\sigma\sqrt{T-t}}\right), \end{aligned} \quad (5.3)$$

$$\begin{aligned} \tilde{X}_t = S_t e^{-\delta(T-t)} & \Phi\left(\frac{\left(r-\delta+\frac{\sigma^2}{2}\right)(T-t) - \ln\left(\frac{K}{S_t}\right)}{\sigma\sqrt{T-t}}\right) \\ & - Ke^{-r(T-t)} \Phi\left(\frac{\left(r-\delta-\frac{\sigma^2}{2}\right)(T-t) - \ln\left(\frac{K}{S_t}\right)}{\sigma\sqrt{T-t}}\right). \end{aligned} \quad (5.4)$$

These stated equations are the generalization result of relevant equations described by A. Shiryaev [3], [4] for dividend payment.

*Result.* If  $\varepsilon = 0$  equations (4.2), (4.7) – (4.9) transform to equations (5.1) – (5.4), that is perfect hedging is the extreme case of quantile hedging.

*Proof* If  $\varepsilon = 0$ , successful hedging probability is as follows  $\mathbf{P}(A) = 1 - \varepsilon = 1$ , that is perfect hedging. Having found  $\Phi(x) + \Phi(-x) = 1$  from (3.13), it follows

$$\begin{aligned} & \Phi\left(\left(b1_c^T - ((\mu-r+\delta)T/\sigma)\right)/\sqrt{T}\right) \\ = & \Phi\left(\left(b2_c^T - ((\mu-r+\delta)T/\sigma)\right)/\sqrt{T}\right), \end{aligned} \quad (5.5)$$

hence,  $b1_c^T = b2_c^T = b_c^T$ . According to equations (4.7), (4.8) and (4.9), as well as, equation (5.5) and  $\Phi(x) + \Phi(-x) = 1$ , we obtain  $\tilde{X}_t = \lim X_t$ ,  $\tilde{\gamma}_t = \lim \gamma_t$ ,  $\tilde{\beta}_t = \lim \beta_t$ , if  $\varepsilon = 0$ .

Then,

$$\begin{aligned} \tilde{X}_t = S_t e^{-\delta(T-t)} & \Phi\left(\frac{(r-\delta+(\sigma^2/2))(T-t) - \ln(K/S_t)}{\sigma\sqrt{T-t}}\right) \\ & - Ke^{-r(T-t)} \Phi\left(\frac{(r-\delta-(\sigma^2/2))(T-t) - \ln(K/S_t)}{\sigma\sqrt{T-t}}\right), \end{aligned}$$

$$\begin{aligned} \tilde{\gamma}_t = e^{-\delta(T-t)} & \left[1 - \Phi(y_0(T-t, S_t) - \sigma\sqrt{T-t})\right] \\ = e^{-\delta(T-t)} & \Phi\left(\frac{(r-\delta+(\sigma^2/2))(T-t) - \ln(K/S_t)}{\sigma\sqrt{T-t}}\right), \end{aligned}$$

$$\begin{aligned} \tilde{\beta}_t = & -\left(\left(e^{-r(T-t)}K\right)/B_t\right) \left[1 - \Phi(y_0(T-t, S_t))\right] \\ = & -\left(\left(e^{-r(T-t)}K\right)/B_t\right) \\ & \Phi\left(\frac{(r-\delta-(\sigma^2/2))(T-t) - \ln(K/S_t)}{\sigma\sqrt{T-t}}\right). \end{aligned}$$

Thus, we have (5.2) – (5.4). If  $\tilde{C}_T = \tilde{X}_0$ , then (5.1) follows from (5.5).

*Proposition 3* Let  $C_T^{S_0} = \partial C_T / \partial S_0$  and  $C_T^K = \partial C_T / \partial K$  be sensitivity coefficients, determined dependences of call-option price for dividend payment at asset initial price  $S_0$  and strike price  $K$ .

If  $[(\mu - r + \delta) / \sigma^2] > 1$ , then we conclude that

$$C_T^{S_0} = e^{-\delta T} \left[ \Phi\left(\frac{b_1^T}{\sqrt{T}} - \sigma\sqrt{T}\right) + \Phi\left(-\frac{b_2^T}{\sqrt{T}} + \sigma\sqrt{T}\right) - \Phi(y_0(T, S_0) - \sigma\sqrt{T}) \right] \quad (5.6)$$

$$C_T^K = -e^{-rT} \left[ \Phi\left(\frac{b_1^T}{\sqrt{T}}\right) + \Phi\left(-\frac{b_2^T}{\sqrt{T}}\right) - \Phi(y_0(T, S_0)) \right] \quad (5.7)$$

The proof follows from the definition of  $C_T^{S_0}$  and  $C_T^K$  which is evident from equations (4.1) and (4.2).

## 6. Conclusions

Numerical calculations of sensitivity coefficients  $C_T^{S_0}$  and  $C_T^K$  showed that  $C_T^{S_0} > 0$ ,  $C_T^K < 0$ . In this case, call option price is an increasing function of asset initial price  $S_0$  and decreasing function of strike price  $K$ . Economic interpretation of these properties are the following: initial price  $S_0$  increment leads to the average increment of  $S_T$ . Thus, probability that  $S_T$  ranks over  $K$  (exercising probability) increases. In this case, option buyer risk decreases, and this reduced risk should be paid for. Strike price increment leads to the average to increment probability that  $S_T$  will not rank over  $K$ . So option buyer risk increases, and increased risk should be paid for.

Numerical calculations showed that call option price is an increasing function of growth coefficient  $\mu$  and decreasing function of parameter  $\varepsilon$ , i. e. increasing function of hedging probability  $\mathbf{P}(A) = 1 - \varepsilon$ . Hence,  $\mu$  increases upward the risk asset price  $S_t$  increases at an average. Thus, probability that  $S_T$  ranks over  $K$  (exercising probability) increases. If investor should pay more for increasing probability to obtain any profit, this could explain the increasing  $C_T$  when  $\mu$  increases. Then  $\varepsilon$  as decreasing hedging probability (probability of payment obligation exercising) declines. Since investor should pay less for decreasing probability to obtain any profit, this could explain the decreasing  $C_T$  when  $\varepsilon$  increases.

## 7. References

- [1] J. Hull, *Options, futures and other derivatives*, Prentice Hall, New Jersey, 2011.
- [2] A. A. Novikov, "Hedging Options with a Given Probability," *Probability Theory and Applications*,

Society for Industrial and Applied Mathematics, 2006, vol.43, no. 1, pp. 135-143.

[3] A. N. Shiryaev, Y. M. Kabanov, and O. O. Kramkov, "Toward the Theory of Pricing of Options of both European and American types. II. Continuous time," *Theory of Probability and Its Applications*, Society for Industrial and Applied Mathematics, 2006, vol. 39, no. 1, pp. 61-102.

[4] A. N. Shiryaev, *Essentials of Stochastic Finance: Facts, Models, Theory*, World Scientific Publishing Company, 1999.

[5] A. V. Melnikov, S. N. Volkov, M. L. Nechaev, *Mathematics of financial obligations (Translations of Mathematical Monographs)*, American Math. Soc., Providence, RI, 2002.

## **Management**

# Measuring Quality of Life Using DEA-AR

Shiuh-Nan Hwang, Hsuan-Shih Lee, Szu-Chia Tang, Shiuh-Sheng Hsu

*Department of Business Administration, Ming Chuan University, Taipei, Taiwan*  
*Department of Shipping and Transportation Management,*  
*National Taiwan Ocean University, Keelung, Taiwan*  
*snhwang@mail.mcu.edu.tw, hslee@axpl.stm.ntou.edu.tw,*  
*vsctang@gmail.com, sunrise18.tw@yahoo.com.tw*

## Abstract

*Dealing with desirable outputs and undesirable outputs is important when measuring Quality of Life (QOL). In addition, the weighting scheme of various QOL indicators must be determined objectively. Many scholars have been applying Data Envelopment Analysis (DEA) to evaluate QOL. However, the general DEA model is not capable of dealing with problems regarding undesirable outputs. This paper proposes a new model with which to evaluate QOL based on the DEA-AR model and the CRITIC method proposed by Diakoulaki et al. (1995). To begin, all QOL indicators, including desirable outputs and undesirable outputs, should be normalized to the-larger-the-better. Secondly, the ranking of QOL indicators by importance is determined through the characteristics of the data and the correlation of inter-indicators; thus this is taken as an objective constraint. This new model possesses higher discrimination than the model proposed by Seiford and Zhu (2002), as proved by an empirical analysis.*

**Keywords:** *undesirable outputs, Quality of Life (QOL), weighting, DEA-AR model, CRITIC method*

## 1. Introduction

The objective of measuring Quality of Life (QOL) is to reflect the general living condition in societies. QOL measurement is not only capable of describing current social conditions and human well-being, but also being helpful in governments' policy making decisions to enhance social development and improve human well-being (Santos et al., 2007; Doi et al., 2008; Fahy and O Cinneide, 2008; Senlier et al., 2009). A consensus that QOL measurement contains multiple subjective and objective indicators has been formed. Subjective indicators emphasize characteristics and life

satisfaction of individuals, including occupation, health status, and lifestyle (Das, 2008; Doi et al., 2008; Lazim and Abu Osman, 2009). Objective indicators, quantitative and secondary data from statistics bureaus, represent the living condition of the whole society and have been

used widely in comparisons among cities or countries due to their equity and convenience.

QOL indicators include desirable outputs and undesirable outputs. Employment rate, disposable income per capita, and life expectancy would be categorized as desirable outputs since these statistics are the-larger-the-better. Unemployment rate, crime rate and concentrations of total suspended particulates would be categorized as undesirable outputs since these statistics represent outputs for which the-smaller-the-better is true. In the process of cities' development and construction, desirable outputs and undesirable outputs often occur simultaneously. For instance, suspended particulates and emissions of water pollutants usually increase associated with developing new areas, constructing roads, and building hospitals and schools. Therefore, both desirable outputs and undesirable outputs should be taken into consideration for QOL measurement.

Many scholars have been applying Data Envelopment Analysis (DEA) to evaluate QOL (Raab et al., 2000 ; Zhu, 2001 ; Somarriba and Pena, 2009). However, the general DEA model is not capable of dealing with problems regarding undesirable outputs. Pittman (1983) was the first researcher to bring the concept of undesirable factors into the field of efficiency evaluation. Subsequently, various scholars proposed different ways to deal with the data of undesirable outputs. Undesirable outputs could be either transformed to multiplicative inverses (Golany and Roll, 1989; Lovell et al., 1995), or be treated directly as inputs (Liu and Sharp, 1999). In addition,

Färe et al. (1989) and Seiford and Zhu(2002) submitted a modified DEA model to solve the problems of undesirable outputs.

Aside from dealing with undesirable outputs, the weighting scheme of QOL indicators is another critical issue in QOL measurement. When calculating a QOL composite index, the weights of various life domains and indicators should be determined, since QOL contains diverse dimensions. Usually, the weighting scheme is decided subjectively through surveys and expert opinions (Boyer and Savageau, 1981; Cummins, 1992), or objectively by multivariate analysis methods (Slotte, 1991; Lee, 2003). A general DEA model is also adopted widely based on QOL measurement since it allows each Decision Making Unit (DMU) to select its favorable weights for evaluating the production efficiency of multi-inputs and multi-outputs (Hashimoto and Kodama, 1997; Somarriba and Pena, 2009).

To conclude, dealing with undesirable outputs and determining the weighing scheme are both essential for QOL measurement. Therefore, this paper proposes a new model for evaluating QOL. To begin with, all QOL indicators, including desirable outputs and undesirable outputs, should be normalized to a scale where the larger the better. Secondly, the ranking of QOL indicators by importance is determined through the characteristics of data and the correlation of inter-indicators; thus, it is taken as an objective constraint. This new model indicates evaluation results that would be more discriminating.

## 2. Background

DEA data type features s+m rows and n columns, which can be described as the following matrix:

$$P = \begin{bmatrix} Y \\ -X \end{bmatrix} = [P_1, \dots, P_n]$$

In the above matrix, each column corresponds to one DMU with s inputs and m outputs. Thus, the data of DMU<sub>j</sub> can be described as follows:

$$P_j = \begin{bmatrix} Y_j \\ -X_j \end{bmatrix}$$

The input vector  $X_{ij}$  and the output vector  $Y_{rj}$ , components of this vector, represent the *i*th input and the *r*th output of DMU<sub>j</sub>.

In advance, outputs  $Y$  can be decomposed into desirable variables  $Y_j^g$  and undesirable variables  $Y_j^b$  (i.e.,  $Y_j = Y_j^g + Y_j^b$ ). Then the raw data can be converted into the following matrix:

$$\begin{bmatrix} Y_j \\ -X_j \end{bmatrix} = \begin{bmatrix} Y_j^g \\ Y_j^b \\ -X_j \end{bmatrix}$$

Based on BCC model (Banker *et al.*, 1984), Färe *et al.* (1989) applied the concept of strong disposability and weak disposability to develop a non-linear DEA model for dealing with undesirable outputs. The efficiency value of DMU<sub>0</sub> can be calculated through equation (1).

$$\begin{aligned} \text{Max} \quad & \Gamma \\ \text{s.t.} \quad & \sum_{j=1}^n z_j x_j + s^- = x_0 \\ & \sum_{j=1}^n z_j y_j^g - s^+ = \Gamma y_0^g \\ & \sum_{j=1}^n z_j y_j^b - s^+ = \frac{1}{\Gamma} y_0^b \\ & \sum_{j=1}^n z_j = 1 \\ & z_j \geq 0, \quad j = 1, \dots, n \end{aligned} \tag{1}$$

In equation (1),  $1/\Gamma$  is the relative efficiency value and  $Z_j$  is the multiplier of inputs and outputs;  $s^-$  and  $s^+$  represent slack variables of inputs and outputs.

As equation (1) is non-linear, Seiford and Zhu (2002) proposed a new model by translating undesirable outputs from negative values into positive ones. In equation (2), undesirable outputs are multiplied by -1 and then coupled with a large enough value of  $w$ . Therefore, equation (1) is modified to be a linear model, as shown in equation (3).

$$y_{j-}^b = y_{j+}^b + w \tag{2}$$



$$\begin{aligned}
 & \text{Max} \quad h & (3) \\
 & \text{s.t.} \quad \sum_{j=1}^n z_j y_j^g \geq h y_0^g \\
 & \quad \quad \sum_{j=1}^n z_j y_j^{-b} \geq h y_0^{-b} \\
 & \quad \quad \sum_{j=1}^n z_j x_j \leq x_0 \\
 & \quad \quad \sum_{j=1}^n z_j = 1 \\
 & \quad \quad z_j \geq 0, \quad j = 1, \dots, n
 \end{aligned}$$

The modified DEA model proposed by Seiford and Zhu (2002) has been adopted widely in the field of environmental efficiency evaluation. Chiu and Wu (2010) applied this model to analyze environmental efficiency of 27 provinces in China by taking emissions of water pollutants and CO<sub>2</sub> as undesirable outputs. Sahoo *et al.* (2011) selected emissions of greenhouse gas as an undesirable output through which to assess environmental efficiency of 22 OECD countries. However, the above research findings indicate that many samples would be judged as efficient DMU<sub>s</sub> by applying this model. Chiu and Wu (2010) found that efficient DMU<sub>s</sub> are postulated from around 40 percent of overall samples each year during the period from 2000 to 2003. Sahoo *et al.* (2011) indicated that efficient DMU<sub>s</sub> account for half of overall samples. Moreover, Seiford and Zhu (2002) presented that efficient DMU<sub>s</sub> account for up to 63 percent of samples. Therefore, this paper proposes a new QOL evaluation model to enhance evaluation discrimination by simultaneously dealing with undesirable outputs and determining the objective weighting scheme of indicators.

### 3. Methodology

#### 3.1 Modified Model from Seiford and Zhu (2002)

QOL indicators contain desirable outputs and undesirable outputs, while inputs are excluded. Thus, all inputs can be treated as a constant  $C_0$  so that

$$\sum_{j=1}^n z_j x_j \leq x_0 \quad \text{is transformed to} \quad \sum_{j=1}^n z_j C_0 \leq C_0 \quad (\text{i.e.,}$$

$$C_0 \sum_{j=1}^n z_j \leq C_0 \quad \text{or} \quad \sum_{j=1}^n z_j \leq 1$$

) in equation (3). In

addition,  $\sum_{j=1}^n z_j \leq 1$  becomes a redundant constraint

$$\sum_{j=1}^n z_j = 1$$

due to  $\sum_{j=1}^n z_j = 1$ . Therefore, equation (3) is modified to become equation (4) to measure QOL, where the larger-the-better QOL indicators are treated as desirable outputs and the smaller-the-better indicators are treated as undesirable outputs.

$$\text{Max} \quad h \quad (4)$$

$$\begin{aligned}
 & \text{s.t.} \quad \sum_{j=1}^n z_j y_j^g \geq h y_0^g \\
 & \quad \quad \sum_{j=1}^n z_j y_j^{-b} \geq h y_0^{-b} \\
 & \quad \quad \sum_{j=1}^n z_j = 1 \\
 & \quad \quad z_j \geq 0, \quad j = 1, \dots, n
 \end{aligned}$$

In equation (4), the multiplicative inverse of  $h$  can be regarded as a QOL composite index. However, equation (4) is solely capable of dealing with undesirable outputs, but is still weak at discrimination as equation (3).

#### 3.2 Modified DEA-AR

The raw data, including desirable outputs and undesirable outputs, is normalized in order to solve the problem of undesirable outputs and to improve the discriminating power of evaluation results as well. As shown in equation (5), statistics are transformed to be the larger-the-better indicators where  $s$  represents the number of evaluation indicators  $f_r$ , while  $y_{ij}$  denotes the score of indicator  $r$  to unit  $j$ ,  $f_r^*$  is the maximum value of indicators  $f_r$  among all DMU<sub>s</sub>, and  $f_{*r}$  is the minimum value of indicators  $f_r$  among all DMU<sub>s</sub>.

$$\bar{y}_{rj} = \frac{y_{rj} - f_{rj}^*}{f_r^* - f_{rj}^*} \quad r=1,2,\dots,s; \quad j=1,2,\dots,n \quad (5)$$

Equation (5) remains unchanged while  $\bar{y}_{rj}$  is the smaller-the-better. Nevertheless,  $f_r^*$  becomes the minimum value of indicators  $f_r$  among all DMUs and  $f_{rj}^*$  becomes the maximum value of indicators  $f_{rj}$  among all DMUs.

The statistics transformed through equation (5) become the-larger-the-better. Therefore, BCC model (Banker *et al.*, 1984) can be modified as equation (6) to measure QOL.

$$\begin{aligned} \text{Max } h_k &= \sum_{r=1}^s u_r Y_{rk} - u_0 & (6) \\ \text{s.t. } & \sum_{i=1}^m v_i X_{ik} = 1 \\ & \sum_{r=1}^s u_r Y_{rj} - \sum_{i=1}^m v_i X_{ij} - u_0 \leq 0, \quad j = 1, \dots, n \\ & u_r, v_i \geq \varepsilon > 0, \quad u_0: \text{ unrestricted,} \\ & r = 1, \dots, s, \quad i = 1, \dots, m \end{aligned}$$

In QOL measurement, various indicators are viewed as outputs while inputs are excluded. Thus, all inputs can be treated as a constant  $C_0$  so that  $\sum_{i=1}^m v_i X_{ij} = \sum_{i=1}^m v_i X_{ik} = \sum_{i=1}^m v_i C_0 = 1$ . Consequently, equation (6) can be replaced with equation (6').

$$\begin{aligned} \text{Max } h_k &= \sum_{r=1}^s u_r Y_{rk} - u_0 & (6') \\ \text{s.t. } & \sum_{r=1}^s u_r Y_{rj} - u_0 \leq 1, \quad j = 1, \dots, n \\ & u_r \geq \varepsilon > 0, \quad u_0: \text{ unrestricted, } r = 1, \dots, s \end{aligned}$$

In the following equation (7), the statistics of QOL indicators  $\bar{y}_{rj}$ , being transformed through equation (5), are taken as desirable outputs  $\bar{y}_{rj}$  in equation (6'). Then equation (7) can be applied to measure QOL where  $h$  can be regarded as a QOL composite index. However, equation (7) is still weak at discrimination as equation (3) and (4).

$$\begin{aligned} \text{Max } h_k &= \sum_{r=1}^s u_r \bar{y}_{rk} - u_0 & (7) \\ \text{s.t. } & \sum_{r=1}^s u_r \bar{y}_{rj} - u_0 \leq 1, \quad j = 1, \dots, n \\ & u_r \geq \varepsilon > 0, \quad u_0: \text{ unrestricted, } r = 1, \dots, s \end{aligned}$$

This paper employs the concept of Assurance Region (AR) proposed by Thompson *et al.* (1990) by restricting weights of various QOL indicators in order to enhance the discrimination of equation (7). Traditional DEA-AR methods usually adopt subjective expert opinions as *a priori* information while setting the range of multiplier  $u_r$ . An objective multiplier is determined in this paper by CRITIC method as developed by Diakoulaki *et al.* (1995). The CRITIC method indicates that the relative importance of an indicator is higher in decision-making process while its correlation with other indicators is lower and its variation of itself is higher. In other words, the importance of an indicator is calculated by the product of the degree of its variation and the degree of non-correlation between indicators.

Therefore, transformed statistics are employed to analyze the degree of correlation between various indicators by accomplishing a correlation matrix where  $r_{rk}$  denotes the correlation coefficient between indicator  $r$  and indicator  $k$ . Moreover, the importance of indicators can be calculated by equation (8). In equation (8),  $R_r$  is the degree of non-correlation between indicator  $r$  and other indicators, and  $\sigma_r$  is the standard deviation of indicator  $r$  corresponding to transformed statistics. The higher the value of  $R_r$  is, the lower the degree of correlation between indicator  $r$  and other indicators is. In addition, the higher the value

of  $\sigma_r$  is, the higher the variation of an indicator is (i.e., this indicator is more important with more information being carried on).

$$R_r = \sum_{k=1}^s (1 - r_{rk}) \quad , \quad r=1, \dots, s, \quad k=1, \dots, s \quad (8)$$

$$C_r = \sigma_r \cdot R_r$$

If  $C_r > C_k$ , then  $u_r > u_k$  in equation (7)

Equation (8) is then added to the constraint of equation (7) as being equation (9), which is the new DEA-AR model developed in this paper.

$$Max h_k = \sum_{r=1}^s u_r y_{rk} - u_0 \quad (9)$$

$$s.t. \quad \sum_{r=1}^s u_r y_{rj} - u_0 \leq 1, \quad j = 1, \dots, n$$

$u_r \geq u_k \geq \varepsilon > 0$ , where the rank of importance of

$u_r$  is determined by equation (8),  $u_0$  unrestricted,  $r = 1, \dots, s$

#### 4. Empirical Results

##### 4.1 Data Set

Taking districts in Taiwan for instance, QOL measurement will be illustrated step by step in this section. Life domains selected by this paper comprise income, employment, health, education, housing, environment, safety, and leisure. One representative indicator is selected from each domain: disposable income per capita ( $Y_1$ ) from the domain of income, unemployment rate ( $Y_2$ ) from the domain of employment, life expectancy at birth ( $Y_3$ ) from the domain of health, percentage of population aged 15 and over with higher education attainment ( $Y_4$ ) from the domain of education, percentage of household income spent on housing costs ( $Y_5$ ) from the domain of housing, concentration of total suspended particulates in the air ( $Y_6$ ) from the domain of environment, violent crime rate ( $Y_7$ ) from the domain of safety, and total areas of park, green area, playground, athletic complex and public squares per 10,000 population ( $Y_8$ ) from the domain of leisure.

There are 8 QOL indicators for each of 20 administrative districts around Taiwan in the year 2000

adopted as outputs in this paper. The statistics are listed in table 1. Among these statistics,  $Y_1, Y_3, Y_4$  and  $Y_8$  are desirable outputs and  $Y_2, Y_5, Y_6$  and  $Y_7$  are undesirable outputs. Each indicator is defined as follows:

Disposable income per capita ( $Y_1$ ): (national disposable income/ mid-year population);

Unemployment rate ( $Y_2$ ): (unemployment population/labor force)\*100;

Life expectancy at birth ( $Y_3$ ): expected number of years of life remaining at birth;

318

Percentage of population aged 15 and over with higher education attainment ( $Y_4$ ): (population with education attainment of junior college and above/population aged 15 and over)\*100;

Percentage of household income spent on housing costs ( $Y_5$ ): [(housing rent + maintenance expenses)/ household income]\*100;

Concentrations of total suspended particulates in the air ( $Y_6$ ): total particulates suspended in the air;

Violent crime rate ( $Y_7$ ): (violent cases/mid-year population)\*100,000;

Total areas of park, green area, playground, athletic complex and public square per 10,000 population ( $Y_8$ ): (the area of park, green area, playground, athletic complex and public square in urban planning areas/ population in urban planning areas) \*10,000.

**Table 1 Statistics of QOL indicators for 20 districts around Taiwan**

DM	Y <sub>1</sub>	Y <sub>2</sub>	Y <sub>3</sub>	Y <sub>4</sub>	Y <sub>5</sub>	Y <sub>6</sub>	Y <sub>7</sub>	Y <sub>8</sub>
New Taipei City	27	2	8	36	2	70	2	1
Taipei City	3,351	2	0.30	99	1.5	.88	4.91	35
Taichung City	40	2	8	60	2	58	2	2
Tainan City	2,056	2	2.42	94	4.4	.83	0.13	65
Taipei City	24	2	7	37	1	61	1	4
Tainan City	1,598	2	8.86	96	8.3	.05	6.31	38
Tainan City	23	1	7	33	1	77	2	4
Kaohsiung City	4,401	.1	8.26	98	8.0	.22	4.81	78
Kaohsiung City	27	2	7	36	1	95	2	4
Kaohsiung City	9,919	2	7.81	46	7.8	.11	9.64	98

Yilan County	24	7	28	1	54	1	2
Taoyuan County	27	7	34	1	55	2	2
Hsinchu County	28	7	34	1	83	2	3
Miaoli County	23	7	26	1	54	8	3
Changhua County	21	7	27	1	10	1	2
Nantou County	22	7	26	1	57	1	3
Yulin County	20	7	24	1	93	1	2
Chiayi County	21	7	22	1	72	1	8
Pingtung County	22	7	26	1	74	2	3
Tainan City	22	7	18	1	64	1	8
Hualien County	25	7	28	1	50	2	1
Penghu County	28	7	29	1	58	2	7
Keelung City	27	7	33	1	76	2	3
Hsinchu City	33	8	45	1	57	1	3
Chiayi City	25	7	48	2	68	1	3
<b>Mean</b>	<b>25</b>	<b>7</b>	<b>32</b>	<b>1</b>	<b>69</b>	<b>1</b>	<b>4</b>
<b>Max</b>	<b>40</b>	<b>8</b>	<b>60</b>	<b>2</b>	<b>10</b>	<b>2</b>	<b>1</b>
<b>Minimum</b>	<b>2,056</b>	<b>4</b>	<b>2.42</b>	<b>.94</b>	<b>4.4</b>	<b>7.67</b>	<b>9.64</b>
<b>Mini-mum</b>	<b>20</b>	<b>7</b>	<b>18</b>	<b>1</b>	<b>50</b>	<b>2</b>	<b>1</b>
<b>Overall</b>	<b>4,811</b>	<b>.1</b>	<b>4.24</b>	<b>.68</b>	<b>4.6</b>	<b>.34</b>	<b>.07</b>

#### 4.2 Efficiency evaluation results

Firstly, statistics in table (1) are evaluated by the Modified Model from Seiford and Zhu (2002), under the name of model (4). Being undesirable QOL indicators,  $Y_2$ ,  $Y_5$ ,  $Y_6$  and  $Y_7$  are transformed by

equation (2), where  $w$  equals to 10, 30, 150, and 50 respectively. Then all data, including converted values, are substituted into equation (4). The results are shown as the second column of table 4. There are 8 DMUs with a QOL composite index which equals 1.

Secondly, statistics in table (1) are transformed to normalized ones by equation (5), as shown in table (2), in which all outputs are desirable QOL indicators. Thus, the data in table (2) are substituted into equation (7) to yield efficiency values for a traditional BCC model, under the name of model (7). The results are listed as the fourth column of table 4. There are 14 DMUs with a QOL composite index which equals 1.

319

**Table 2 Normalized statistics of QOL indicators for 20 districts around Taiwan**

DM	Y <sub>1</sub>	Y <sub>2</sub>	Y <sub>3</sub>	Y <sub>4</sub>	Y <sub>5</sub>	Y <sub>6</sub>	Y <sub>7</sub>	Y <sub>8</sub>
U	1	2	3	4	5	6	7	8
New Taipei City	0	0	.740	0	.295	0	0	0
Taipei City	.3475	.6667	.8	.4333	.9	.6417	.3921	.0001
Tainan City	1	0	.000	1	.000	0	0	0
Taipei City	.0000	.6667	0	.0000	.1	.8519	.5193	.1194
Tainan City	0	0	.564	0	.622	0	0	0
Tainan City	.1865	.6667	.8	.4562	.4	.8132	.6210	.2782
Tainan City	0	1	.491	0	.653	0	0	0
Tainan City	.1500	.0000	.4	.3620	.1	.5311	.3947	.3150
Kaohsiung City	0	0	.436	0	.673	0	0	0
Kaohsiung City	.3808	.6667	.4	.4207	.5	.2191	.0001	.3333
Yilan County	0	1	.501	0	.744	0	0	0
Yilan County	.2291	.0000	.2	.2286	.9	.9269	.7030	.1230
Taoyuan County	0	0	.645	0	.622	0	0	0
Taoyuan County	.3430	.3333	.5	.3680	.4	.9145	.4078	.0845
Hsinchu County	0	1	.522	0	.704	0	0	0
Hsinchu County	.3962	.0000	0	.3628	.1	.4164	.3117	.2020
Miaoli County	0	0	.497	0	.724	0	0	0
Miaoli County	.1312	.3333	.6	.1843	.5	.9283	.8179	.2020
Changhua County	0	0	.558	0	.724	0	0	0
Changhua County	.0381	.6667	.7	.2075	.5	.0001	.6793	.0652

Nantou County	0.1222	0.3333	0.3912	0.1943	0.8469	0.8727	0.6220	0.2305
Yulin County	0.0001	0.0000	0.3472	0.1299	0.8367	0.2507	0.6857	0.0882
Chiayi County	0.0598	0.0000	0.4230	0.0852	0.0000	0.6122	0.6500	0.6896
Pingtung County	0.0923	0.0000	0.2103	0.1761	0.8469	0.5866	0.2185	0.1781
Taitung County	0.0917	0.0001	0.0001	0.0001	0.6020	0.7605	0.5608	0.6171
Hualien County	0.2355	0.0001	0.0880	0.2314	0.7347	0.0000	0.3894	0.0000
Penang County	0.4180	0.0000	0.6247	0.2463	0.7755	0.8510	0.0000	0.5813
Keelung City	0.3465	0.6667	0.4914	0.3575	0.8367	0.5423	0.4762	0.2039
Hsinchu City	0.6630	0.6667	0.7286	0.6240	0.7347	0.8744	0.6109	0.1965
Chiayi City	0.2308	0.0000	0.5685	0.7042	0.4388	0.6862	0.5677	0.1690

Thirdly, statistics in table (2) are used in equation (8). The ranking of 8 QOL indicators by importance is calculated based on correlation statistics and are listed in table 3. The result of ranking is  $Y_2 > Y_8 > Y_5 > Y_6 > Y_4 > Y_7 > Y_1 > Y_3$ . Unemployment rate ( $Y_2$ ) is the most important, followed by total areas of park, green area, playground, athletic complex and public square per 10,000 population ( $Y_8$ ) and percentage of household income spent on housing costs ( $Y_5$ ). On the other end, life expectancy at birth ( $Y_3$ ) is the least important.

Following, the ranking of indicators by importance in table (3) is input into equation (9) (i.e.,  $u_2 > u_8 > u_5 > u_6 > u_4 > u_7 > u_1 > u_3$ ) to calculate efficiency values of the DEA-AR model developed in this paper, under the name of model (9). The results are listed in the sixth column of table 4. There are 2 DMU<sub>s</sub> with a QOL composite index of 1. To conclude, the discrimination of model (9) is better than that provided by other models.

**Table 3 Ranking of indicators by importance**

Indicator	QOL Indicator	Importance	Rank
$Y_2$	Unemployment rate	2.2865	1
$Y_8$	Total areas of park, green area, playground, athletic complex and public square per 10,000 population	1.9046	2
$Y_5$	Percentage of household income spent on housing costs	1.8272	3
$Y_6$	Concentrations of total suspended particulates in the air	1.7176	4
$Y_4$	Percentage of population aged 15 and over with higher education attainment	1.4504	5
$Y_7$	Violent crime rate	1.4057	6
$Y_1$	Disposable income per capita	1.3993	7
$Y_3$	Life expectancy at birth	1.3343	8

According to the evaluation result of model (9), the best QOL ranking for Taiwan goes to Chiayi County

and Penghu County. With regard to Chiayi County, performances of  $Y_2, Y_5, Y_7, Y_8$  are better than average. Concerning Penghu County, performances of QOL indicators are all better than average except for  $Y_4$ . The worst QOL ranking around Taiwan goes to Changhua County, followed by Taitung County and New Taipei City. In Changhua County, performances of  $Y_1, Y_4, Y_6, Y_8$  are lower than average. In Taitung County, performances of  $Y_1, Y_2, Y_3, Y_4, Y_5$  are lower than average. In New Taipei City, performances of  $Y_5, Y_6, Y_7, Y_8$  are lower than average.

**Table 4 Efficiency evaluation results of QOL4.3 Comparison of models**

DMU	Model (4)	Rank	Model (7)	Rank	Model (9)	Rank
New Taipei City	0.99	2	0.87	6	0.90	17
Taipei City	1.00	1	1.00	1	0.92	12
Taichung City	0.97	9	0.91	3	0.94	8
Tainan City	0.98	6	1.00	1	0.95	5
Kaohsiung City	1.00	1	0.89	5	0.91	15
Yilan County	0.95	13	1.00	1	0.96	2
Taoyuan County	1.00	1	1.00	1	0.90	16
Hsinchu County	0.98	5	1.00	1	0.94	7
Miaoli County	0.99	3	1.00	1	0.92	14
Changhua County	1.00	1	0.89	4	0.89	19
Nantou County	0.98	4	1.00	1	0.92	13
Yunlin County	0.96	11	1.00	1	0.93	11
Chiayi County	1.00	1	1.00	1	1.00	1
Pingtung County	0.95	2	1.00	1	0.94	6
Taitung County	1.00	1	0.81	7	0.90	18
Hualien County	1.00	1	1.00	1	0.94	9
Penghu County	1.00	1	1.00	1	1.00	1

Keelung City	0.97	8	0.97	2	0.93	10
Hsinchu City	0.98	7	1.00	1	0.95	3
Chiayi City	0.97	10	1.00	1	0.95	4

Further, Wilcoxon rank sum test (a method of nonparametric statistics) is used to compare models in pairs to see if there are statistically significant differences among model (4), model (7), and model (9). The analysis results are listed as table 5, indicating that there are significant differences among the models and discrimination of model (9) is significantly better than another two models.

**Table 5 Variance analysis of models**

Model	Mean	Standard Deviation	Number of DMUs	Pairwise Comparison	Wilcoxon
Model (4)	0.98	0.014	8	(4) vs. (7)	-0.341
Model (7)	0.96	0.054	14	(7) vs. (9)	2.548**
Model (9)	0.93	0.028	2	(9) vs. (4)	3.636**

Note: \*\*at the  $\alpha=0.05$  level of significance, \*\*\*at the  $\alpha=0.01$  level of significance

## 5. Conclusion

Since QOL indicators simultaneously comprise desirable outputs and undesirable outputs, either a traditional DEA model applying normalized data or a modified DEA model dealing with undesirable outputs was used to measure QOL in the past. However, importance of all QOL indicators should be taken into consideration to be more practical. Therefore, a new model which combines CRITIC method and DEA-AR model is proposed in this paper to solve the abovementioned issue of dichotomy in QOL measurement. Firstly, the CRITIC method is applied to normalize all data to the-larger-the-better. Secondly, the ranking of QOL indicators by importance is determined and then substituted into the new DEA-AR model. This new model is proved to be more discriminating and practical by statistical comparisons among models. In future research, scholars may apply this new DEA-AR model in the field of QOL evaluation.

## References

- [1] Banker, R. D., Charnes, A. and Cooper, W. W., 1984, "Some Models for Estimating Technical and Scale Inefficiencies in Data Envelopment Analysis," *Management Science*, Vol. 30, No. 9, pp. 1078-1092.
- [2] Boyer, R. and Savageau, D., 1981, *Places Rated Almanac*, Chicago: Rand McNally.
- [3] Chiu, Y. H. and Wu, M. F., 2010, "Environmental Efficiency Evaluation in China: Application of Undesirable Data Envelopment Analysis," *Polish Journal of Environmental Studies*, Vol. 19, No. 6, pp. 1159-1169.
- [4] Cummins, R. A., 1992, *Comprehensive Quality of Life Scale-Intellectual Disability*, Melbourne: Psychology Research Centre.
- [5] Das, D., 2008, "Urban Quality of Life: A Case Study of Guwahat," *Social Indicator Research*, Vol. 88, No. 2, pp. 297-310.
- [6] Diakoulaki, D., Mavrotas, G. and Papayannakis, L., 1995, "Determining Objective Weights in Multiple Criteria Problems: The Critic Method," *Computers & Operations Research*, Vol. 22, No. 7, pp. 763-770.
- [7] Diener, E. and Suh, E., Suh. 1997, "Measuring Quality of Life: Economic, Social, and Subjective Indicators," *Social Indicators Research*, Vol. 40, pp. 189-216.
- [8] Doi, K., Kii, M. and Nakanishi, H., 2008, "An Integrated Evaluation Method of Accessibility, Quality of Life, and Social Interaction," *Environment and Planning B: Planning and Design*, Vol. 35, No. 6, pp. 1098-1116.
- [9] Fahy, F. and O Cinneide, M., 2008, "Developing and Testing an Operational Framework for Assessing Quality of Life," *Environmental Impact Assessment Review*, Vol. 28, pp. 366-379.
- [10] Färe, R., Grosskopf, S., Lovell, C. A. K., and Pasurka, C., 1989, "Multilateral Productivity Comparisons when Some Outputs are Undesirable: a Nonparametric Approach," *The Review of Economics and Statistics*, Vol. 71, pp. 90-98.
- [11] Golany, B. and Roll, Y., 1989, "An Application Procedure for DEA," *Omega: The International Journal of Management Science*, Vol. 17, pp. 237-250.
- [12] Grasso, M. and Canova, L. 2008, "An Assessment of the Quality of Life in the European Union Based on the Social Indicators Approach," *Social Indicators Research*, Vol. 87, pp. 1-25.
- [13] Hashimoto, A. and Kodama, M. 1997, "Has Livability of Japan Gotten Better for 1956-1990?: a DEA Approach," *Social Indicators Research*, Vol. 40, pp. 359-373.
- [14] Lazim, M. A. and Abu Osman, M. T., 2009, "A New Malaysian Quality of Life Index Based on Fuzzy Sets and Hierarchical Needs," *Social Indicators Research*, Vol. 94, pp. 499-508.
- [15] Lee, H. S., 2003. "Objective Quality of Life in Korea and the OECD Countries," *Social Indicators Research*, Vol. 62, pp. 481-508.
- [16] Liu, W. B. and Sharp, J., 1999, *DEA Models via Goal Programming*. In G. Westerman (Ed.), *Data envelopment analysis in the public and private sector*, Deutscher Universitäts-Verlag.
- [17] Lovell, C. A. K., Pastor, J. T. and Turner, J. A., 1995, "Measuring Macroeconomic Performance in the OECD: a Comparison of European and Non-European Countries," *European Journal of Operational Research*, Vol. 87, pp. 507-518.
- [18] Pittman, R. W., 1983, "Multilateral Productivity Comparisons with Undesirable Outputs," *The Economic Journal*, Vol. 93, pp. 883-891.
- [19] Raab, R., Kotamraju, P. and Haag, S., 2000. "Efficient Provision of Child Quality of Life in Less Developed Countries: Conventional Development Indexes versus A Programming Approach to Development Indexes," *Socio-Economic Planning Science*, Vol. 34, pp. 51-67.
- [20] Sahoo, B. K., Luptacik, M. and Mahlberg, B., 2011, "Alternative Measures of Environmental Technology Structure in DEA: an Application," *European Journal of Operational Research*, Vol. 215, pp. 750-762.
- [21] Santos, L. D., Martins, I. and Brito, P., 2007, "Measuring Subjective Quality of Life: A Survey to Porto's Residents," *Applied Research in Quality of Life*, Vol. 2, pp. 51-64.



- [22] Seiford, L. W. and Zhu, J., 2002, "Modeling Undesirable Factors in Efficiency Evaluation," *European Journal of Operational Research*, Vol. 142, pp. 16-20.
- [23] Senlier, N., Yildiz, F. and Aktas, E. D., 2009, "A Perception Survey for the Evaluation of Urban Quality of Life and Kocaeli and a Comparison of the Life Satisfaction with the European Cities," *Social Indicators Research*, Vol. 94, pp. 213-226.
- [24] Slottje, D. J., 1991, "Measuring the Quality of Life across Countries," *The Review of Economics and Statistics*, Vol. 73, No. 4, pp. 684-693.
- [25] Somarriba, N. and Pena, B., 2009, "Synthetic Indicators of Quality of Life in Europe," *Social Indicators Research*, Vol. 94, No. 1, 115-133.
- [26] Sufian, A. M., 1993, "A Multivariate Analysis of the Determinants of Urban Quality of Life in the World's Largest Metropolitan Areas," *Urban Studies*, Vol. 30, No. 8, pp. 1319-1329.
- [27] Thompson, R. G., Langemeier, L. N., Lee, E. and Thrall, R. M., 1990, "The Role of Multiplier Bounds in Efficiency Analysis with Application to Kansas Farming," *Journal of Econometrics*, Vol. 46, pp. 93-108.
- [28] Zhu, J. 2001. "Multidimensional Quality-of-Life Measure with An Application to Fortune's Best Cities." *Socio-Economic Planning Science*, Vol. 35, pp. 263-284.

# A Combined Model with the Four Travel Choices and Variable Demand

Huey-Kuo Chen

Department of Civil Engineering, National Central University, Taiwan

[ncutone@ncu.edu.tw](mailto:ncutone@ncu.edu.tw)

## Abstract

*Sequential four-step travel demand forecasting consists of four steps, i.e., trip generation, trip distribution, modal split and traffic assignment. This sequential procedure has long been used as a pedagogical and practical device in the area of transportation area for more than 60 years. Though its concept is easy to be understood, this sequential procedure has also been criticized for its internal inconsistencies between the four steps as well as for its slow convergence to final solutions. In this paper a unified model that combines the four-step travel choices as well as variable demand is proposed to cope with the internal inconsistency problem whilst a nested solution algorithm that embeds a quick-precision solution algorithm called "B" algorithm is adopted for the solutions.*

*The formulated combined model can be meaningfully interpreted by a structured supernetwork and tactically treated as a series of extended traffic assignment problems. It implies that any traffic assignment algorithm is applicable to solve this extended traffic assignment problem, i.e., our proposed combined model. The proposed model and the "B" algorithm are further demonstrated with a numerical example. As compared with the traditional Frank-Wolfe method for traffic assignment, the proposed solution algorithm outperforms in terms of solution quality and computational efficiency. A few remarks conclude the paper.*

## 1. Introduction

The transportation planning process as it is usually carried out consists of four travel choices: trip origins (TO) or frequency of travel, trip distribution (TD) or origin-destination, mode choice (MC), and traffic assignment (TA) or route choice. Traditionally these four travel choices are performed as a top-down procedure resulting in so called sequential travel demand forecasting (STDF). The STDF is simple to implement, however, the entire procedure takes a huge amount of computation time for a median or large scale

network and, moreover, is hardly to obtain a satisfactory result. The low precision of the STDF is due to the link costs which correspond to the final estimated traffic flows obtained from the traffic assignment model are, however, not in general the same as those assumed at the trip distribution stage (Evans, 1976) or more generally, any earlier step.

To overcome this problem, Evans combined trip distribution and traffic assignment into one stage and describing them by one model. The combined model is then reformulated as an equivalent optimization problem which was solved by the proposed algorithm, known as Evans' algorithm or the double-stage solution algorithm. Later other algorithms such as generalized Benders decomposition (Jörnsten, 1980), disaggregate simplicial decomposition (DSD) algorithm (Larsson and Patriksson, 1991) have been developed to improve the computational efficiency. Evans also indicated that further combined models include the assignment problem with elastic demand, combined modal split, trip distribution and traffic assignment. Sheffi (1985) has intensively treated as extended user equilibrium a variety of combined models using a modified network representation, which is termed supernetworks. The supernetwork representation that generally contain both physical network for traffic assignment and several virtual networks for other travel choices (Chen, 2011) can be used to interpret how the formulated combined models can be meaningfully solved in an associated structured supernetwork.

In addition to trip distribution and traffic assignment, user equilibrium with variable demand, and equilibrium between modes, Sheffi (1985) also discussed several other more complicated combined models such as joint modal split/traffic assignment, modal split/trip distribution/traffic assignment, trip generation/modal split/trip distribution/traffic assignment by which associated supernetwork representations were provided. (Note: in Sheffi's book (1985), the combined trip generation/modal split/trip distribution/traffic assignment model and its associated

supernetwork representation are essentially for the combined modal split/trip distribution/traffic assignment problem with variable demand). Though not explicitly expressed in his book, Sheffi (1985) may already consider any user equilibrium solution algorithm applicable to the aforementioned combined models.

Though there have been fruitful publications concerning combined models in the literature, e.g., Beckmann, McGuire, and Winsten [1, 1956], Sheffi [2, 1985], Patriksson [3, 1994], Oppenheim [4, 1995], Boyce, LeBlanc and Chon [5, 1988], Boyce [6, 1990; 7, 1998] and Boyce and Bar-Gera [8, 2003; 9, 2004], Chen (2011), to the best knowledge of the authors, there is only one article has talked about the most complicated combined model, i.e., the combined trip generation/modal split/trip distribution/traffic assignment model problem with variable demand (called TG/MS/TD/TA/VD hereafter). This combined model has been demonstrated with a simple symmetric network using the well known Frank-Wolfe algorithm, but indicated that more efficient algorithms are needed for combined models (Chen, 2011). Unfortunately this proposed solution algorithm is valid only for some simple networks. Therefore, more sophisticated solution is needed for general transportation networks. In this article, we revisit the combined TG/MS/TD/TA/VD model and indicate that it may not be correctly solved using any traffic assignment solution algorithm without necessary modifications. Hence a “correct” solution procedure is needed.

In addition, the traffic assignment solution algorithm has made amazing progress in the last decade. Efficient algorithms such as “B” [30, Dial, 2006], OBA [31, Bar-Gera, 2002], TAPAS [32, Bar-Gera, 2010, 33, Bar-Gera and Boyce, 2007, 34, Boyce et al., 2010a, 35, Boyce et al., 2010b], LUCE [36, Florian, 2009] as well as the projected gradient [17, Florian, 2009] could be more efficient than traditional solution algorithms. While this assertion is effective for the combined models that involve fewer travel choices, it cannot be applied to the four-step combined travel choice models in general. Therefore the supernetwork presentation must be interpreted with caution and a new (nested) solution algorithm must be developed.

In the following, we will formulate the TO/TD/MC/TA/VD problem as an optimization model in Section 2. Section 3 proposes a nested solution algorithm and presents a supernetwork presentation for it. Section 4 demonstrates the model and solution algorithm with numerical examples. Section 5 concludes the paper with a few remarks.

## 2. Model formulation for the combined TO/TD/MC/TA/VD problem

The combined TO/TD/MC/TA/VD problem considers all travel choices as well as the variable demand in a unified framework. This model enables the relationship between the sectors of urban planning and transportation being more precisely studied. We formulate it as an optimization model in the following.

As an optimization model, the combined TO/TD/MC/TA/VD problem must consist of an objective function and a feasible region that includes three types of constraints (i.e., flow conservation, non-negativity and definitional constraints).

$$\begin{aligned} \min_{(x, q_m^{rs}, q^r) \in \Omega} z = & \\ & \sum_m \sum_l \int_0^{x_{ml}} c_{ml}(\omega) d\omega + \sum_s \sum_m \int_0^{q_m^s} c_m^s(\omega) d\omega + \\ & \sum_m \sum_{s'} \int_0^{q_m^{s'}} c_m^{s'}(\omega) d\omega + \sum_{s'} \sum_{r'} \int_0^{q^{s'r'}} c^{s'r'}(\omega) d\omega \\ & + \sum_{r'} \int_0^{q^r} c^{r'O'}(\omega) d\omega - \int_0^q D^{-1}(\omega) d\omega \end{aligned}$$

where the feasible region  $\Omega$  is defined by the following constraints.

Flow conservation constraints:

$$\sum_p f_{mp}^{rs} = q_m^{rs} \quad \forall r, s, m \quad (1b)$$

$$\sum_m q_m^{rs} = q^{rs} \quad \forall r, s \quad (1c)$$

$$\sum_r q_m^{rs} = q_m^s \quad \forall r, s \quad (1c')$$

$$\sum_s q^{rs} = q^r \quad \forall r \quad (1d)$$

$$\sum_r q^r = q \quad (1e)$$

$$q + e = \bar{q}_{\max} \quad (1f)$$

Non-negativity constraints:

$$f_{mp}^{rs} \geq 0 \quad \forall r, s, m, p \quad (1g)$$

Definitional constraints:

$$x_{ml} = \sum_r \sum_s \sum_p f_{mp}^{rs} \delta_{mlp}^{rs} \quad \forall m, l \quad (1h)$$

$$c_{mp}^{rs} = \sum_l c_{ml} \delta_{mlp}^{rs} \quad \forall r, s, m, p \quad (1i)$$

where

$c_{ml}$ : the travel cost function associated with link  $l$  and mode  $m$

$c_m^s$ : travel cost function that characterize mode choice for destination  $s$

$c_m^{s'}$ : travel cost function that characterize destination  $s$  for mode  $m$

$c^{r'O'}$  : travel cost function that characterizes trip generation for origin  $r$

$c^{s'r'}$  : travel cost for link  $s'r'$  that connect origin  $r$  and destination  $s$

$D^{-1}(q)$ : the inverse demand function; equivalent to the excess demand function  $E(e)$

$e$  : the excess flow associated with the entire area,  
 $e = \bar{q}_{\max} - q$

$q$  : the total OD trip rate from the entire area

$q^r$  : the total OD trip rate from origin  $r$ ; flows on link  $r'O'$

$q^{r's'}$  : trip rate between origin  $r'$  and destination  $s'$ ; flows on link  $s'r'$

$q_m^{rs}$  : the total flow by mode  $m$  between origin  $r$  and destination  $s$

$q_m^{s'}$  : the total flow by mode  $m$  between origin  $r$  and destination  $s$ ; flows on link  $ms'$

$q_m^s$  : the total flow by mode  $m$  between origin  $r$  and destination  $s$ ; flows on link  $sm$

$\bar{q}_{\max}$  : the upper limit of total OD trip rate from the entire area

$\delta_{mlp}^{rs}$  : 1, if link  $l$  associated with mode  $m$  is on path  $p$  between O-D pair  $rs$ .

Eq. (1a) defines the objective function by summing the integrals of link travel costs for all links, including real links for traffic assignment and virtual links for modal choice, trip distribution, trip origin as well as variable demand. Eq. (1b) conserves flows for each O-D pair by mode  $m$ . Eq. (1c) conserves flows for each O-D pair. Eq. (1c') conserves flows for destination  $s$  by mode  $m$ . Eq. (1d) conserves flows for each origin  $r$ . Eq. (1e) conserves flows for the entire area. Eq. (1f) sets the upper limit of total traffic demand for the entire area. Eq. (1g) requires path flow associated with each mode and route be negative. Eqs. (1h) and (1i) are definitional constraints.

For demonstration purpose, the link travel costs of the virtual links are assumed based mainly on the logit formula, as follows:

$$c_m^s = 0 \quad (2a)$$

$$c_m^{s'} = \frac{1}{\theta} \ln q_m^s - M_m \quad (2b)$$

$$c^{s'r'} = \frac{1}{\gamma} \ln q^{rs} - M^s \quad (2c)$$

$$c^{r'O'} = \frac{1}{\eta} \ln q^r \quad (2d)$$

$$c^{OO'} = D^{-1}(q) \quad (2e)$$

where

$M^s$ : the attractiveness measure associated with destination  $s$

$M_m$  : the preference parameter associated with mode  $m$

$\theta, \gamma, \eta$  : the logit function dispersion parameters associated with, respectively, modal choice, trip distribution and trip generation

Then, the above mathematical model can be rewritten as follows:

$$\begin{aligned} \min_{(x, q_m^s, q^{rs}, q^r, q)} z = & \\ & \sum_m \sum_l \int_0^{x_{ml}} c_{ml}(\omega) d\omega + \sum_m \sum_{s'} \int_0^{q_m^{s'}} \left( \frac{1}{\theta} \ln \omega - M_m \right) d\omega \\ & + \sum_{s'} \sum_{r'} \int_0^{q^{r's'}} \left( \frac{1}{\gamma} \ln \omega - M^s \right) d\omega + \sum_{r'} \int_0^{q^{r'O'}} \left( \frac{1}{\eta} \ln \omega \right) d\omega \\ & - \int_0^q D^{-1}(\omega) d\omega \end{aligned} \quad (3a)$$

The corresponding supernetwork representation can be drawn in Figure 1:

$r, r'$ : origin;  $s, s'$ : destination;  $m$ : mode;  $M$ : attractiveness;  $\theta, \gamma, \eta$ : dispersion parameter  
 $l, 2, l', 2'$ : origin;  $3, 4, 5, 3', 4', 5'$ : destination;  $O, O'$ : superorigin;  $O'$ : superdestination  
TA: traffic assignment; MC: mode choice; TD: trip distribution; TG: trip generation;  
VD: variable demand  
 $c^{O'} = 0$ ;  $c_{transit}^{rs} = u_{transit}^{rs}$ ;  $c^m = 0$ ;  $c^{m'} = \frac{1}{\theta} \ln q_m^s - M_m$ ;  $c^{s'r'} = \frac{1}{\gamma} \ln q^{rs} - M^s$ ;  $c^{r'O'} = \frac{1}{\eta} \ln q^r$

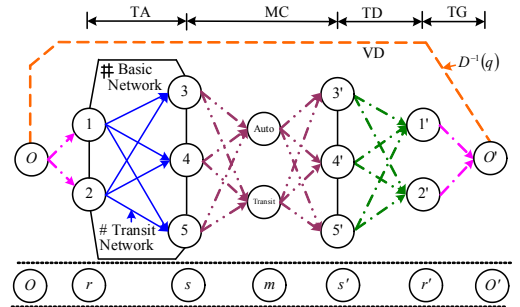


Figure 1. Supernetwork for the combined TO/TD/MC/TA/VD model

It is clear that the objective function associated with the virtual network can be further divided into four subclasses, i.e., route choice, mode choice, trip distribution, trip origins, as well as variable demand. Note that the flow over the excess link  $O \rightarrow O'$  denotes the flow of “nontravelers” in the network being studied.

### 3. Solution algorithm for the combined TO/TD/MC/TA/VD problem

The TO/TD/MC/TA/VD model (1) is difficult to solve because flow conservation constraints, i.e., (1b)-(1f), must be satisfied at all four steps of the trip generation, trip distribution, modal split, and route choice, as well as variable demand functions. To solve this problem, suitable methods must take advantage of the network structure. In general, there are two ways in developing such types of solution algorithms. The first is to dualize all flow conservation constraints except that for route choice and then adopt the augmented Lagrangian method for the solutions. However, the difficulty associated with this type of solution algorithm is that dual update converges very slow and hence computationally extensive.

The second approach adopts the concept of take-and-conquer techniques. This approach solves the whole TO/TD/MC/TA/VD model by treating flow conservation constraints one at a time, resulting in a nested solution algorithm. In detail, we solve the area-wide trip generation problem with variable demand (ATO/VD) at first. With the obtained area-wide trip rates, we solve the trip generation and assignment (TO/TA) problem. With the obtained trip rates associated with each origin, we then solve the trip distribution and assignment (TD/TA) problem, resulting in O-D trip rates, which are in turn used to solve the modal split and assignment (MC/TA) problem. The obtained O-D trip rates by mode are then used for solving the mode-specific traffic assignment problem. This solution procedure is conceptually similar to the traditional four-step sequential demand forecasting procedure but without having internal inconsistency problems between any two consecutive steps. It is noticed that each of the above mentioned combined models can be treated as “extended” traffic assignment problem and hence any traffic assignment solution algorithm can be readily adopted for solutions. Since traffic assignment solution algorithms have made great advancement in the last decade, the second approach that embeds a series of traffic assignment solution procedures is therefore more effective in terms of both performance efficiency and solution precision.

With the above description, we now proposed a nested solution algorithm that solves a series of combined travel choice models as follows:

Step 0: input traffic data including upper limit of trips for the entire traffic area, traffic demand functions respectively for the entire traffic area, for each origin-destination pair, for each modes as well as

link relevant data such as free flow link travel costs, link capacities and link cost functions.

- Step 1: solve the area-wide trip assignment problem with variable demand (ATO/VD) resulting in the trip rates for the entire area.
- Step 2: solve the trip origin and assignment (TO/TA) problem, resulting in trip rates for each origin.
- Step 3: solve the trip distribution and assignment (TD/TA) problem, resulting in O-D trip rates.
- Step 4: solve the modal split and assignment (MC/TA) problem, resulting in the O-D trip rates by mode.
- Step 5: solve the mode-specific traffic assignment problem.
- Step 6: stop.

In the following section, we elaborate the model formulation as well as supernetworks associated with steps 1 to 5, respectively.

#### 3.1. Model formulation and its supernetwork for the combined ATO/VD problem

The ATO/VD model can be formulated as follows:

$$\begin{aligned} \min_{(x, q_m^s, q^r, q^s, q)} z = & \\ & \sum_m \sum_l \int_0^{x_{ml}} c_{ml}(\omega) d\omega + \sum_m \sum_{s'} \int_0^{q_m^{s'}} \left( \frac{1}{\theta} \ln \omega - M_m \right) d\omega \\ & + \sum_{s'} \sum_{r'} \int_0^{q^{r's'}} \left( \frac{1}{\gamma} \ln \omega - M^s \right) d\omega + \sum_{r'} \int_0^{q^{r'o}} \left( \frac{1}{\eta} \ln \omega \right) d\omega \\ & - \int_0^q D^{-1}(\omega) d\omega \end{aligned} \quad (4a)$$

where the feasible region  $\Omega_1$  is defined by the following constraints.

Flow Conservation Constraints:

$$\sum_r \sum_s \sum_m \sum_p f_{mp}^{rs} = q \quad (4b)$$

$$q + e = \bar{q}_{\max} \quad (4c)$$

Non-negativity Constraints:

$$f_{mp}^{rs} \geq 0 \quad \forall r, s, m, p \quad (4d)$$

Definitional Constraints:

$$x_{ml} = \sum_r \sum_s \sum_p f_{mp}^{rs} \delta_{mlp}^{rs} \quad \forall m, l \quad (4e)$$

$$c_{mp}^{rs} = \sum_l c_{ml} \delta_{mlp}^{rs} \quad \forall r, s, m, p \quad (4f)$$

The corresponding supernetwork representation is the same as Figure 1.

#### 3.2. Model formulation and its supernetwork for the combined TO/TA Problem

The TO/TA model can be formulated as follows:

$$\begin{aligned} & \min_{(x, q_m^s, q^{rs}, q^r, q) \in \Omega_2} z = \\ & \sum_m \sum_l \int_0^{x_{ml}} c_{ml}(\omega) d\omega + \sum_m \sum_{s'} \int_0^{q_m^{s'}} \left( \frac{1}{\theta} \ln \omega - M_m \right) d\omega \\ & + \sum_{s'} \sum_{r'} \int_0^{q^{r's'}} \left( \frac{1}{\gamma} \ln \omega - M^s \right) d\omega + \sum_{r'} \int_0^{q^{r'o'}} \left( \frac{1}{\eta} \ln \omega \right) d\omega \end{aligned} \quad (5a)$$

where the feasible region  $\Omega_2$  is defined by the following constraints.

Flow conservation constraints:

$$\sum_s \sum_m \sum_p f_{mp}^{rs} = q^r \quad \forall r \quad (5b)$$

$$\sum_r q^r = \bar{q} \quad (5c)$$

Non-negativity constraints:

$$f_{mp}^{rs} \geq 0 \quad \forall r, s, m, p \quad (5d)$$

Definitional constraints:

$$x_{ml} = \sum_r \sum_s \sum_p f_{mp}^{rs} \delta_{mlp}^{rs} \quad \forall m, l \quad (5f)$$

$$c_{mp}^{rs} = \sum_l c_{ml} \delta_{mlp}^{rs} \quad \forall r, s, m, p \quad (5g)$$

The corresponding supernetwork representation can be drawn in Figure 2:

$r, r'$ : origin;  $s, s'$ : destination;  $m$ : mode;  $M$ : attractiveness;  $\theta, \gamma, \eta$ : dispersion parameter  
 $1, 2, 1'$ : origin;  $3, 4, 5, 3', 4', 5'$ : destination;  $O$ : superorigin;  $O'$ : superdestination  
 TA: traffic assignment; MC: mode choice; TD: trip distribution; TG: trip generation; VD: variable demand  
 $c^{O'r} = 0$ ;  $c_{Transit}^{rs} = u_{Transit}^{rs}$ ;  $c^{sm} = 0$ ;  $c^{m's'} = \frac{1}{\theta} \ln q_m^s - M_m$ ;  $c^{s'r'} = \frac{1}{\gamma} \ln q^{rs} - M^s$ ;  $c^{r'o'} = \frac{1}{\eta} \ln q^r$

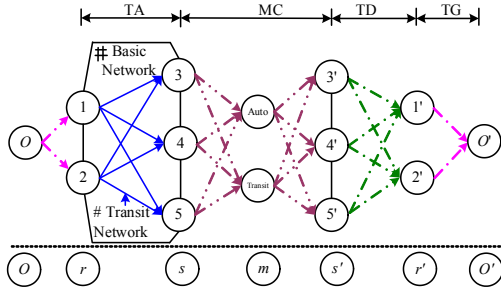


Figure 2. Supernetwork for combined TO/TA model

### 3.3. Model formulation and its supernetwork for the combined TD/TA problem

The TD/TA model can be formulated as follows:

$$\begin{aligned} & \min_{(x, q_m^s, q^{rs}, q^r, q) \in \Omega_3} z = \\ & \sum_m \sum_l \int_0^{x_{ml}} c_{ml}(\omega) d\omega + \sum_m \sum_{s'} \int_0^{q_m^{s'}} \left( \frac{1}{\theta} \ln \omega - M_m \right) d\omega \\ & + \sum_{s'} \sum_{r'} \int_0^{q^{r's'}} \left( \frac{1}{\gamma} \ln \omega - M^s \right) d\omega \end{aligned}$$

where the feasible region  $\Omega_3$  is defined by the following constraints.

Flow conservation constraints:

$$\sum_m \sum_p f_{mp}^{rs} = q^{rs} \quad \forall r, s \quad (6b)$$

$$\sum_s q^{rs} = \bar{q}^r \quad \forall r \quad (6c)$$

Non-negativity constraints:

$$f_{mp}^{rs} \geq 0 \quad \forall r, s, m, p \quad (6d)$$

Definitional constraints:

$$x_{ml} = \sum_r \sum_s \sum_p f_{mp}^{rs} \delta_{mlp}^{rs} \quad \forall m, l \quad (6e)$$

$$c_{mp}^{rs} = \sum_l c_{ml} \delta_{mlp}^{rs} \quad \forall r, s, m, p \quad (6f)$$

The corresponding supernetwork representation can be drawn in Figure 3:

$r, r'$ : origin;  $s, s'$ : destination;  $m$ : mode;  $M$ : attractiveness;  $\theta, \gamma, \eta$ : dispersion parameter  
 $1, 2, 1'$ : origin;  $3, 4, 5, 3', 4', 5'$ : destination;  $O$ : superorigin;  $O'$ : superdestination  
 TA: traffic assignment; MC: mode choice; TD: trip distribution; TG: trip generation; VD: variable demand  
 $c^{O'r} = 0$ ;  $c_{Transit}^{rs} = u_{Transit}^{rs}$ ;  $c^{sm} = 0$ ;  $c^{m's'} = \frac{1}{\theta} \ln q_m^s - M_m$ ;  $c^{s'r'} = \frac{1}{\gamma} \ln q^{rs} - M^s$ ;  $c^{r'o'} = \frac{1}{\eta} \ln q^r$

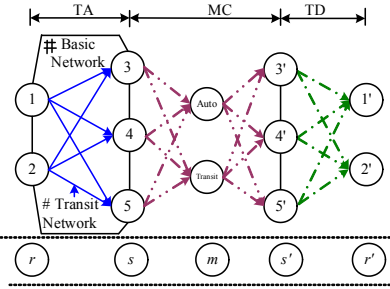


Figure 3. Supernetwork for combined TD/TA model

### 3.4. Model formulation and its supernetwork for the combined MC/TA problem

The MC/TA model can be formulated as follows:

$$\begin{aligned} & \min_{(x, q_m^s, q^{rs}, q^r, q) \in \Omega_4} z = \\ & \sum_m \sum_l \int_0^{x_{ml}} c_{ml}(\omega) d\omega + \sum_m \sum_{s'} \int_0^{q_m^{s'}} \left( \frac{1}{\theta} \ln \omega - M_m \right) d\omega \end{aligned}$$

where the feasible region  $\Omega_4$  is defined by the following constraints.

Flow conservation constraints:

$$\sum_r \sum_p f_{mp}^{rs} = q_m^s \quad \forall s, m \quad (7b)$$

$$\sum_m \sum_p f_{mp}^{rs} = \bar{q}^{rs} \quad \forall r, s \quad (6a)7c)$$

Non-negativity constraints:

$$f_{mp}^{rs} \geq 0 \quad \forall r, s, m, p \quad (7d)$$

Definitional constraints:

$$x_{ml} = \sum_r \sum_s \sum_p f_{mp}^{rs} \delta_{mlp}^{rs} \quad \forall m, l \quad (7e)$$

$$c_{mp}^{rs} = \sum_l c_{ml} \delta_{mlp}^{rs} \quad \forall r, s, m, p \quad (7f)$$

The corresponding supernetwork representation can be drawn in Figure 4:

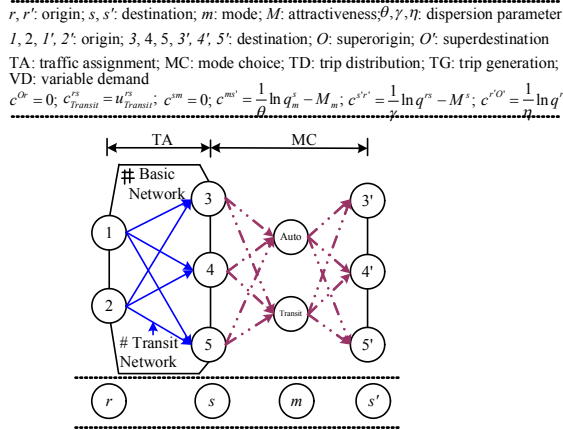


Figure 4. Supernetwork for combined MC/TA model

### 3.5. Mode-specific traffic assignment problem

The mode-specific traffic assignment problem can be formulated as follows:

$$\min_{(x, q_m^s, q^{r'}, q^r, q) \in \Omega_5} z = \sum_m \sum_l \int_0^{x_{ml}} c_{ml}(\omega) d\omega \quad (8a)$$

where the feasible region  $\Omega_5$  is defined by the following constraints.

Flow conservation constraints:

$$\sum_p f_{mp}^{rs} = \bar{q}_m^{rs} \quad \forall r, s, m \quad (\mu_m^{rs}) \quad (8b)$$

Non-negativity constraints:

$$f_{mp}^{rs} \geq 0 \quad \forall r, s, m, p \quad (8c)$$

Definitional constraints:

$$x_{ml} = \sum_r \sum_s \sum_p f_{mp}^{rs} \delta_{mlp}^{rs} \quad \forall m, l \quad (8d)$$

$$c_{mp}^{rs} = \sum_l c_{ml} \delta_{mlp}^{rs} \quad \forall r, s, m, p \quad (8e)$$

The corresponding supernetwork representation can be drawn in Figure 5:

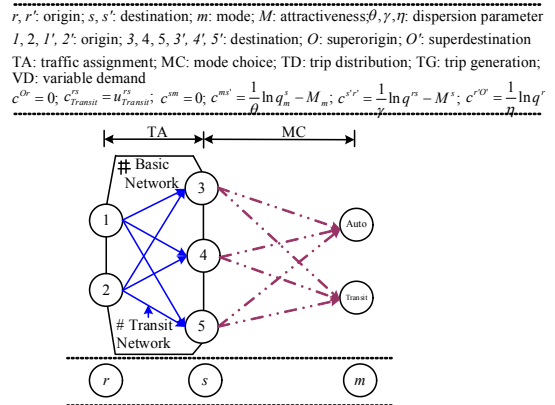


Figure 5. Supernetwork for mode-specific TA model

The supernetwork representation for the combined TO/TD/MC/TA/VD model that is depicted in Figure 2 cannot be directly regarded as an “extended” traffic assignment problem if all the flow constraints (1b)-(1f) must be satisfied simultaneously. As can be seen in Figure 2, the trip origins generated at  $O$  to 1 for origin  $r^1$  may not be coincident with that at  $1'$  to  $O'$  (also for origin  $r^1$ ), the same situation occurs for the trip origins generated at  $O$  to 2 for origin  $r^2$  and at  $2'$  to  $O'$  (also for origin  $r^2$ ), implying the constraints of trip origins cannot be conserved in general.

However, it is worth noting that each of the above five combined submodels can be regarded as “extended” traffic assignment and solved using any available traffic assignment algorithm. The remaining issue is which of the available traffic assignment algorithms should be adopted for solving each of the five combined submodels.

There are several of such algorithms available in the literature, including the traditional Frank-Wolfe algorithm [13, Frank and Wolfe, 1956] and efficient quick-precision methods [14, Bar-Gera, 2010, 15, Nie, 2010, 16, Dial, 2006, 17, Florian, 2009]. The Frank-Wolfe algorithm, though simple and more suitable for pedagogical purposes, is not efficient and may become obsolete for solving large-scale traffic assignment problems. On the other hand, efficient quick-precision methods have been well developed and tested in the last decades. For the purpose of demonstration, here we simply adopt “B” Solution Algorithm for use.

### 4. Numerical example for the combined TO/TD/MC/TA/VD problem

To demonstrate, we take a 21-link (indexed from 1 to 21) 12-node supernetwork (Chen, 2011) for testing, as shown in Figure 6.



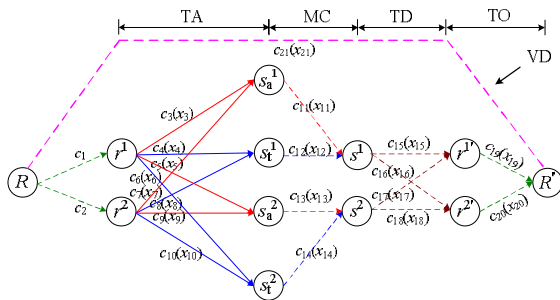


Figure 6. Test network (supernetwork for TO/TD/MC/TA with variable demand)

The relevant data are given in Table 1:

Table 1. Input Data

Link Function	Cost	Link Function	Cost	Demand
$c_1 = 0$		$c_2 = 0$		$\bar{q}_{\max} = 1$
$c_3 = 0.4 + 0.2x_3$		$c_7 = 0.5 + 0.4x_9$		
$c_4 = 8$		$c_8 = 8.5$		
$c_5 = 0.5 + 0.4x_5$		$c_9 = 0.4 + 0.2x_7$		
$c_6 = 8.5$		$c_{10} = 8$		
$c_{11} = \ln x_{11}$		$c_{13} = \ln x_{13}$		
$c_{12} = \ln x_{12}$		$c_{14} = \ln x_{14}$		
$c_{15} = \ln x_{15}$		$c_{17} = \ln x_{17}$		
$c_{16} = \ln x_{16}$		$c_{18} = \ln x_{18}$		
$c_{19} = \ln x_{19}$		$c_{20} = \ln x_{20}$		
$c_{21} = D_r^{-1}(\cdot) = E(\cdot) = 5 + 2x_{21}$				

The four-step combined model with variable demand can be solved by the “B” algorithm without any difficulty. The obtained results for link flows, link costs as well as dual variables are the same as those from the Frank-and-Wolfe algorithm (Chen, 2011) and hence listed in Table 2:

Table 2: Computational Results

Link Function	Cost	Link Function	Cost	Equilibrium Condition

$c_1 = 0$	$c_2 = 0$	$x_1 = x_3 + x_4 + x_5 + 96.29936$
$c_3 = 0.4 + 0.2x_3 = 7.148814$	$c_7 = 0.5 + 0.4x_9 = 13.9976$	$x_2 = x_7 + x_8 + x_9 + 96.29936$
$c_4 = 8$	$c_8 = 8.5$	$x_{11} = x_3 + x_7 = 67.48814$
$c_5 = 0.5 + 0.4x_5 = 13.99763$	$c_9 = 0.4 + 0.2x_7 = 7.148814$	$x_{12} = x_4 + x_8 = 28.81123$
$c_6 = 8.5$	$c_{10} = 8$	$x_{13} = x_5 + x_9 = 67.48814$
$c_{11} = \ln x_{11} = 4.211952$	$c_{13} = \ln x_{13} = 4.211952$	$x_{14} = x_6 + x_{10} = 28.81123$
$c_{12} = \ln x_{12} = 3.360766$	$c_{14} = \ln x_{14} = 3.360766$	$x_{15} + x_{16} = x_{11} + x_{12} = 48.14968 * 2$
$c_{15} = \ln x_{15} = 3.874315$	$c_{17} = \ln x_{17} = 3.874315$	$x_{17} + x_{18} = x_{13} + x_{14} = 48.14968 * 2$
$c_{16} = \ln x_{16} = 3.874315$	$c_{18} = \ln x_{18} = 3.874315$	$x_{19} = x_{15} + x_{17} = 96.29936$
$c_{19} = \ln x_{19} = 4.567462$	$c_{20} = \ln x_{20} = 4.567462$	$x_{20} = x_{16} + x_{18} = 96.29936$
$c_{21} = D_r^{-1}(\cdot) = E(\cdot) = 5 + 2x_{21} = 19.80254$		$x_{21} = \bar{q}_{\max} - x_{19} - x_{20} = 7.401271$

It is observed that the obtained solution completely complies with the following conditions:

- (1) variable demand: the inverse demand is equal to the minimum travel time from all origins.
- (2) trip origins: The computed results for trip origins satisfy the assumed logit formula.
- (3) trip distribution: The computed results for trip distribution satisfy the assumed logit formula.
- (4) mode choice: The computed results for mode split are consistent with the logit formula.
- (5) traffic assignment: The computed path travel times for all the used paths are exactly the same (19.80254 units)

which imply a generalized Wardrop equilibrium.

Overall, the results obtained are conformed to our hypothetical cost functions for different travel choices. In a more strict sense, the travelers' behavior that uses a minimum path and adopts logit formula for other travel choices is fully satisfied with this most complicated combined model.

## 5. Conclusion and suggestions

In this paper, we have presented a novel solution algorithm for the combined model with the four travel choices and variable demand. This novel algorithm employs a nested structure that essentially solves five combined submodels in sequel. In detail, we solve the area-wide trip generation problem with variable demand (ATO/VD) at first. With the obtained area-wide trip rates, we solve the trip generation and assignment (TO/TA) problem. With the obtained trip rates associated with each origin, we then solve the trip distribution and assignment (TD/TA) problem, resulting in O-D trip rates, which are in turn used to solve the modal split and assignment (MC/TA) problem. The obtained O-D trip rates by mode are then used for solving the mode-specific traffic assignment problem. This solution procedure is conceptually similar to the traditional four-step sequential demand forecasting procedure but without having internal inconsistency problems between any two consecutive steps.

It is noticed that each of the above mentioned combined models can be treated as "extended" traffic assignment problem and hence any traffic assignment solution algorithm can be readily adopted for solutions. In view of the amazing development of the quick-precision traffic assignment solution algorithms in the last decade, any such solution algorithm like "B" algorithm can make the proposed solution procedure more effective in terms of both performance efficiency and solution precision. However, how much improvement can be obtained as compared with traditional four-step sequential demand forecasting procedure (with or without feedback) becomes an immediate future research.

## 6. Acknowledgement

This work was supported in part by the National Science Council, Taiwan under grant No. NSC-100-2221-E-008-093-MY3.

## 7. References

- [1] M. Abdulaal, and L. J. LeBlanc, "Methods for combining modal split and equilibrium assignment models", *Transportation Science*, vol. 13, pp. 292–314, 1979.
- [2] H. Bar-Gera, "Origin-based algorithm for the traffic assignment problem", *Transportation Science*, vol. 36, no. 4, pp. 398–417, 2002.
- [3] H. Bar-Gera, "Traffic assignment by paired alternative segments (TAPAS)", *Transportation Research part B*, vol. 44, pp. 1022–1046, 2010.
- [4] H. Bar-Gera, and D.E. Boyce, "Solving the sequential procedure with feedback", paper presented at the *Sixth International Conference of Chinese Transportation Professionals*, Dalian, China, 2006.
- [5] H. Bar-Gera, and D.E. Boyce, "Some amazing properties of road traffic network equilibria", In: *Network Science, Nonlinear Science and Infrastructure Systems*, Ed. T. L. Friesz, Springer: Berlin, pp. 305–335, 2007.
- [6] M. Beckmann, C. B. McGuire, and C. B. Winsten, *Studies in the Economics of Transportation*, Yale University Press: New Haven, 1956.
- [7] D.E. Boyce, "Network equilibrium models of urban location and travel choices: a new research agenda", In: *New Frontiers in Regional Science*, Eds. M. Chatterji, and R. E. Kuenne, Macmillan: New York, pp. 238–256, 1990.
- [8] D. E. Boyce, "Long-term advances in the state of the art of travel forecasting methods", In *Equilibrium and Advanced Transportation Modelling*, Eds. P. Marcotte, and S. Nguyen, Kluwer: Dordrecht, pp. 73–86, 1998.
- [9] D.E. Boyce, *Urban Travel Forecasting Course Notes*, 2007a. [online] Available: [www.civil.northwestern.edu/people/boyce.html](http://www.civil.northwestern.edu/people/boyce.html). [Accessed Dec. 28, 2007].
- [10] D.E. Boyce, "Forecasting travel on congested urban transportation networks: review and prospects for network equilibrium models", *Network and Spatial Economics*, vol. 7, pp. 99–128, 2007b.
- [11] D.E. Boyce, and H. Bar-Gera, "Validation of multiclass urban travel forecasting models combining origin-destination, mode, and route choices", *Journal*

of *Regional Science*, vol. 43, pp. 517–540, 2003.

[12] D.E. Boyce, and H. Bar-Gera, “Multiclass combined models for urban travel forecasting”, *Network and Spatial Economics*, vol. 4, pp. 115–124, 2004.

[13] D.E. Boyce, L.J. LeBlanc, and K.S. Chon, 1988, “Network equilibrium models of urban location and travel choices: a retrospective survey”, *Journal of Regional Science*, vol. 28, pp. 159–183.

[14] D.E. Boyce, M. Lupa, and Y. Zhang, “Introducing ‘feedback’ into four-step travel forecasting procedure vs. equilibrium solution of combined model”, *Transportation Research Record*, vol. 1443, pp. 65–74, 1994.

[15] D.E. Boyce, Y. Nie, H. Bar-Gera, Y. Liu, and Y. Hu “Consistent route flows and the condition of proportionality”, paper presented at the *2010 Annual Meeting of the Transportation Research Board*, Washington, DC, 2010a.

[16] D.E. Boyce, Y. Nie, H. Bar-Gera, Y. Liu, and Y. Hu, *Field Test of a Method for Finding Consistent Route Flows and Multiple-Class Link Flows*, draft report to the Federal Highway Administration, Washington, DC, 2010b.

[17] D.E. Boyce, C.R. O'Neill, and W. Scherr, “New results on solving the sequential travel forecasting procedure with feedback”, paper presented at the *Seventeenth PTV Vision User Group Meeting*, Berlin, 2007.

[18] H.K. Chen, “Supernetwork Representations for Combined Travel Choice Models,” *Open Transportation Journal*, Vol. 5, pp. 92-104, 2011.

[19] H.K. Chen, and Y.C. Chen, “Comparisons of the Frank-Wolfe and Evans methods for the doubly constrained entropy distribution/assignment problem”, *Journal of the Eastern Asia Society for Transportation Studies*, vol. 3, no. 1, pp. 261–276, 1999.

[20] H.K. Chen, and H.W. Chou, “Supply chain network equilibrium problem with capacity constraints”, *Papers in Regional Science*, vol. 87, no. 4, pp. 605–621, 2008.

[21] R.B. Dial, “A path-based user-equilibrium traffic assignment algorithm that obviates path storage and

enumeration”, *Transportation Research part B*, vol. 40, pp. 917–936, 2006.

[22] S.P. Evans “Derivation and analysis of some models for combining trip distribution and assignment”, *Transportation Research*, vol. 10, pp. 37–57, 1976.

[23] C. Frank, *A Study of Alternative Approaches to Combined Trip Distribution-Assignment Modeling*, PhD dissertation, Regional Science, University of Pennsylvania, Philadelphia, 1978.

[24] M. Frank, and P. Wolfe, “An algorithm for quadratic programming”, *Naval Research Logistics Quarterly*, vol. 3, pp. 95–110, 1956.

[25] M. Florian, I. Constantin, and D. Florian, “A new look at the projected gradient method”, In *CD-ROM of TRB 2009 Annual Meeting*, 2009.

[26] M. Florian, and S. Nguyen, “A combined trip distribution modal split and assignment model”, *Transportation Research*, vol. 12, pp. 241–246, 1978.

[27] M. Florian, S. Nguyen, and J. Ferland, “On the combined distribution-assignment of traffic”, *Transportation Science*, vol. 9, pp. 43–53, 1975.

[28] N.H. Gartner, “Optimal traffic assignment with elastic demands, a review: part II: algorithmic approaches”, *Transportation Science*, vol. 14, no. 2, pp. 192–208, 1980.

[29] G. Gentile, “Linear user cost equilibrium: a new algorithm for traffic assignment”, Submitted to *Transportation Research Part B*, 2009.

[30] K.O. Jörnsten, *Generalized Benders decomposition: a method to solve the combined traffic assignment and traffic signal optimization problem*, The Department, Northwestern University, 1980.

[31] L.J. LeBlanc, and K. Farhangian, “Efficient algorithms for solving elastic demand traffic assignment problems and mode-split assignment problems”, *Transportation Science*, vol. 15, pp. 306–317, 1981.

[32] J.T. Lundgren and M. Patriksson, “The combined distribution and stochastic assignment problem”, *Annals of Operations Research*, vol. 82, pp. 309–329, 1998.

- [33] T. Larsson, M. Patriksson, Simplicial Decomposition with Disaggregated Representation for the Traffic Assignment Problem, *Transportation Science*, vol. 26, no. 1, pp. 4-17, 1992.
- [34] A. Nagurney, *Network Economics: A Variational Inequality Approach*, Kluwer Academic Publishers: Massachusetts, 1993.
- [35] Y. Nie, “A class of bush-based algorithms for the traffic assignment problem”, *Transportation Research part B*, vol. 44, no. 1, pp. 73–89, 2010.
- [36] N. Oppenheim, *Urban Travel Demand Modeling*, Wiley: New York, 1995.
- [37] M. Patriksson, *The Traffic Assignment Problem: Models and Methods*, VSP: Utrecht, 1994.
- [38] Y. Sheffi, *Urban Transportation Networks: Equilibrium Analysis with Mathematical Programming Methods*, Prentice-Hall Inc: New Jersey, USA, 1985.
- [39] J.D. Siegel, J. De Cea, J.E. Fernández, E.E. Rodríguez, and D.E. Boyce, “Comparisons of urban travel forecasts prepared with the sequential procedure and a combined model”, *Networks and Spatial Economics*, vol. 6, pp. 135–148, 2006.
- [40] R.L. Tobin, and T. Friesz, “Sensitivity analysis for equilibrium network flow”, *Transportation Science*, vol. 22, no. 4, pp. 242–250, 1988.
- [41] J.G. Wardrop, “Some theoretical aspects of road traffic research”, In *Proceedings of Institution of Civil Engineers, Part II*, no. 1, pp. 325–378, 1952

# Evidence on Relationship between Derivatives Selection and Hedge effectively in Integrated Circuit Industry

Chin-Tsai Lin<sup>a</sup> Wan-Rung Lin<sup>b</sup> Yi-Hsien Wang<sup>b\*</sup> Ping-Hui Huang<sup>b</sup>

<sup>a</sup> Dept. Business Administration, Ming Chuan University, Taipei, Taiwan

<sup>b</sup> Dept. Banking and Finance, Chinese Culture University, Taipei, Taiwan  
[holland@mail2000.com.tw](mailto:holland@mail2000.com.tw)

## Abstract

*In response to the trend of the rapid international financial integration, it is a common practice for Taiwan's enterprises to operate financial derivatives for hedging. However, most of the previous literature focuses on foreign exchange risk, while seldom discusses the interest risk of high level of correlation with operating costs. Based on literature review, this paper uses the Multinomial Logistic to explore whether same hedging tools have been used to hedge interest risk before and after the outbreak of the financial crisis in case of the two business models. Furthermore, it explores whether the selected hedging financial products can effectively avoid the interest risk and the major internal financial factors of the company will significantly affect the profits when operating the hedging commodities. It is expected that the findings of this research can provide relevant enterprises and investors with a reference in making decisions for using financial products for hedging purposes.*

*Keywords: Interest risk; Derivatives; financial crisis; hedging*

## 1. Introduction

Trend of globalization and financial liberalization has become more and more popular in many countries around the world. It not only has led to the emergence of many financial products, but also more frequent cross-border financial transactions. In condition of rapid development of many financial products and financial liberalization, traditional financial products may no longer satisfy the various types of demand. According to the summary of the inter-bank financial derivatives trading volume sourced from the statistics of the Central Bank of Taiwan, it has suggested that Taiwan's enterprises should mainly engage in interest rate-related contracts and foreign exchange rate-related contracts in financial derivative trading. The exchange rate-related contracts mostly involve in volume, while, the trading volumes of equity security contracts,

commodity-related contracts and credit-related contracts are gradually increasing. The rapid development and innovation of financial derivatives with low transaction costs may meet the multiple demand of the hedging of enterprises. However, the characteristics of high leverage and implied high risks will result to many problems arising from excessive operation.

In recent years, many well-known enterprises in Taiwan and abroad have suffered great losses from inappropriate operations of financial derivatives. For example, the British Barings Bank, more than 200 years history, filed for bankruptcy due to the improper operation in one of its branches. The government of the Orange County, California went bankrupt after suffering a 1.7 billion USD loss in financial derivatives trading. In 2008, the U.S. subprime crisis and the Lehman Brothers scandal caused the global financial tsunami. The above examples illustrated that improper control of human risks will lead to major losses. The application of derivatives can effectively hedge exchange rate and interest rate risks, reduce financing costs and improve assets returns, consequently it may be good risk manage tool. Moreover, improper operation may lead seriously impact on profit of the enterprise and investors, even the bankruptcy of the company.

Taiwan is a free and open economy and an export-oriented country. To attract foreign investment, Taiwan has been applying the policy of free movement of capital. In response to the exporting industries, the central bank has implemented the stable foreign exchange rate policy. However, during the global financial crisis, monetary policies of low interest rate were adopted to vitalize Taiwan's economy, and one of the above polices had to be sacrificed. In [1] the authors in an open and free economy, the independent and self-controlling monetary policy, stable exchange rate and free movement of capital cannot coexist. Only two of them can coexist with the other one being abandoned. This point of view is termed as the

trilemma of open economy. Hence, the business operation is an issue of considerable concern to managers and administrators. Managers can sense changes in the market and rapidly adjust business strategy of the enterprises by following the industrial development.

Regarding the mode of industrial development, with Taiwan's IC industry as an example, the IC industry has undergone three major revolutions, and developed two business models of vertical integration (Integrated Device Manufacturing, IDM) and virtual integration. The two business models coexist and compete with each other. Which one of them can have lower operating risk by comparison of the two business models in the IC industry? How the enterprises can take the most effective method to reduce losses and even gain profits out of the crisis? As a result, financial derivatives were created. The use of funds is vital to enterprises, in case of frequent changes in foreign exchange rate and interest rate. What is the best hedging strategy in case of the two business models? Do the hedging strategies are significantly effective? Moreover, in the background of dramatic social changes, financial crisis is common and has great impact. What are the approaches to select appropriate financial derivatives in different environments? The above are the motivations for this study.

Previous studies have discussed the use of financial derivatives to hedge in the face of foreign exchange rate risk and the discussions on the interest rate risk in the of financial crisis are rare. During the global financial crisis, the different levels of sensitivity in the balance sheets of enterprises lead to different due dates of debts, different accounting basis or the cash flow uncertainty arising from the financial contracts of floating interest rates. Hence, this paper aims to find out how Taiwan's IC industry can effectively avoid interest rate risk in case of two business models. To hedge the interest rate risk, enterprises may use multiple types of hedging tools and the result of affecting factors, the effectiveness of using financial derivatives before and after financial crisis are worthy for further discussions. Hence, these are listed as key points for in-depth discussions in this study.

Hence, the research questions of this paper are

*1.1. What are the variables of the motivation of using financial derivatives to hedge in case of Taiwan's IC industry?*

*1.2. What are the differences of the motivation variables of using financial derivatives to hedge in case of selection of different types of hedging commodities and the impact of interest rate?*

*1.3. Before and after the occurrence of the*

*financial crisis, are the hedging commodities same and effective in case of two business models?*

## **2. Literature Review**

The discussions on the scope of hedging decision making factors regarding of the use of financial derivatives are extensive, and can be divided into four points, as listed below: 1) facing financial crisis or not; 2) the agency problem; 3) company size; and 4) growth investment

### *1.4. Financial Crisis*

In [2] the capital structure irrelevance theory proposed by Modigliani and Miller has pointed out that the company's corporate structure does not affect corporate value. According to this theory, regardless of the debts of the company, the financial crisis has no cost and its value is identical with capital costs. However, if the financial crisis has costs, then the company will have incentives to reduce the probability of the occurrence of financial crisis. In [3] the authors suggested that the costs of financial crisis will result in fluctuations in corporate value, and urged enterprises to take hedging activities to reduce the probability of the occurrence of financial crisis. In [4] the authors argued that hedging will increase borrowing power of the company, and high financial leverage will also increase the incentives to hedge. Since borrowing will result in leverage-related costs, the occurrence probability of financial crisis will be highly related to the extent of using financial leverages by the company. In [5] the authors pointed out that enterprises having lower interest coverage ratio and higher financial leverage will have higher probability of financial crisis, and thus have stronger hedging motivation [6] [7] [8]. Previous studies also suggested that enterprises having higher long term debt ratio will use interest swap as a tool for interest rate risk management. In [9] the authors suggested that the reason for enterprises to hedge is that lower debt ratio means smaller probability of financial crisis of the company, and thus, hedging can obtain greater benefits for the company. In [7] Finding in empirical study of the author is that financial leverage and hedging of the company are positively correlated, indicating that enterprises of greater financial leverage will be more likely to use financial derivatives for interest rate risk hedging transactions [8].

### *1.5. Agency Problem*

In [3] [10] [11] the authors proposed that the separation of ownership and operating power will create the agency problem between creditors and shareholders who provide capital, and the managers

who use the capital, resulting in agency costs. There will be a conflict of creditors and shareholders are different from the management in terms of interests, and thus creates the agency problem. In [12] the authors suggested that company managers often tactically smoothen the earnings of the company because of the fear of losing job from poor performance, and stabilize the fluctuations of earnings to lower the vocational risk. Whereas, the managers cannot lower the risk of the job by market investment portfolios so they will take the corporate hedging behaviors. Other studies have proposed different viewpoints. In [13] the authors argued that, if the managerial shareholding percentage is relatively high, the hedging behaviors for the company will be reduced as the managers are relatively unconcerned about poor performance and will spare no efforts to maximize corporate value. In [14] the author found the agency problem is more serious in case of using foreign exchange rate financial derivatives than the interest rate financial derivatives [15] [16].

#### 1.6. Company Size

In [17] According to the information economies of scale assumption, the authors argued that large enterprises are more capable of inviting professional managers to use financial derivatives for hedging with lower transaction costs on average. Hence, company size is correlated to hedging operations. In [18] [19] Boyer et al., Pennings and Garcia had the same opinions. In [20] the authors analyzed the American banking industry, and found that the engagement in hedging behavior is positively correlated to company size. In other words, the information and transaction costs have the effects of economies of scale, which are greater than the impact of fund raising costs or financial crisis costs [21] [22] [23] [24].

However, some scholars have different opinions concerning the impact of company size on the hedging motivation of the company. In [25] [26] the authors suggested that smaller enterprises will tend to take more risk management behaviors to avoid expensive external financing costs. In [27] the author

Table 1.  
VI Model

Taiwanese Listed Company Code	
2337	5326
2342	5346
2344	5387
2408	

empirically found that small enterprises cannot fully take advantage of the economies of scale as they have to face to market uncertainty. However, the diversification of assets of the large enterprises is easier and the external financing is more easily. As a result, small enterprises will have more hedging activities.

#### 1.7. Growth Investment

In [28] the authors proposed that it will result in waste and additional cost when cash flow is generated externally. To raise corporate value, the enterprises will use financial derivatives for hedging to mitigate the fluctuations in cash flow of the company to distribute the redundant capital to places in short of cash flow, in order to increase the investment opportunities [4]. In [29] the author used the research and development rate to measure the company's growth investment opportunities, and suggested that they are significantly and positively correlated. This indicates that enterprises having more growth investment opportunities will be more likely to use financial derivatives for hedging. In [11] [30] the authors used the research and development cost as the variable to measure growth opportunities, and the empirical results suggested that enterprises of potentials will use the hedging tools to reduce fluctuations in cash. Since enterprises with growth opportunities are prone to the problem of insufficient funds, this can satisfy the investment needs of the company. Based on the above, when the company is faced with high growth investment opportunities, hedging can reduce the problem of insufficient investment [8] [24] [31] [32] [33].

## 2. Research Method and Procedures

### 2.1. Sample Period and Data Sources

According to IC industrial structural evolution diagram to class, there are two kinds of business models: Vertical Integration (IDM), Virtual Integration (VI). In this study, the research period is from 2007 to 2011 when the financial crisis occurred. The 5 years are divided into 9 periods of each half of a year.



Table2.  
IDM Model

Taiwanese Listed Company Code					
2379	3041	5487	6236	8261	2449
2388	3126	6103	6237	8299	3264
2401	3129	6104	6243	2303	3372
2436	3268	6129	6286	2330	5455
2454	3288	6130	6291	1437	6147
2458	3289	6138	8016	2311	6239
3006	5302	6198	8054	2325	6257
3014	5314	6202	8081	2329	6261
3034	5351	6229	8084	2369	8079
3035	5471	6233	8096	2441	

The research subjects are the listed and OTC enterprises in the IC industry on Taiwan Stock Exchange. This paper deletes the enterprises in the non-IC industries and samples of incomplete disclosure during the research period (including delisted enterprises and newly listed enterprises). The following table illustrates the selection of research samples. The data used in this study are secondary and the primary data from:

1. Taiwan Economic Journal Database as the source of sample selection and measurement variables.

2. Data relating to the hedging by using financial derivatives obtained from the financial statements on the public information observation website of Taiwan Stock Exchange.

3. Relevant disclosure data in the annual reports and prospectus of listed and OTC enterprises in Taiwan.

Table 3.  
Sample Selection

Number of Original Samples	13,291
Delete:	
1. Samples in the non-IC industry	(13271)
2. Samples of incomplete disclosure (including delisted and newly listed enterprises)	(8)
Number of valid samples	66

Note: a term lasts for half a year, a total of 9 terms.

## 2.2.

### 2.3. Variable Definition

By referring to the definitions of the variables of relevant empirical studies, this paper summarizes and illustrates the following research variables as below. The research period unit is a half of year and all the following variables are semi-annual information:

#### 2.3.1. Financial crisis variables

Enterprises of higher financial crisis occurrence probability or higher financial crisis costs will be more likely to use financial derivatives for hedging. When the expected debt ratio is greater, the interest coverage is smaller and the operating margin is lower. The probability of the occurrence of financial crisis of the company will be greater and the use of hedging will be more likely. Hence, this paper uses debt ratio, interest rate coverage and operating margin for variable definition.

$$\begin{aligned} \text{Ratio of Debt (DEB)} &= \frac{\text{Total Liabilities}}{\text{Total Asset}} \\ \text{Time Interest Earned (TIE)} &= \frac{\text{EBIT}}{\text{Interest Tax}} \end{aligned} \quad (2)$$

$$\text{Operating Margin (OM)} = \frac{\text{Gross Profit}}{\text{Net sales}} \quad (3)$$

#### 2.3.2. Agency cost variables

When managerial shareholding percentage is lower, the incentive to hedge for the company will be at a greater level. This paper uses the managerial shareholding percentage and the institutional shareholding percentage as the variables defined below

$$\text{Managerial Shareholding (MS)} = \frac{\text{the ordinary shares hold by manager and board members}}{\text{Total number of Outstanding ordinary shares}} \quad (4)$$

#### 2.3.3. Company Size Variables

Enterprises with higher operating income are more capable of managing risks, leading to higher probability of financial derivatives. This paper uses the net operating income as the variable defined below:

$$\begin{aligned} \text{Operating Income (OI)} &= \text{Net Operating Income} \end{aligned}$$

#### 2.3.4. Company's growth investment opportunity variables

Previous studies suggest that hedging can reduce the problem of insufficient investment, reduce external fund-raising costs and the dependence on external financing. Hence, this paper uses operating income

growth rate and the research and development rate to define the following variables:

$$\begin{aligned} \text{Growth Rate (GW)} &= \frac{\text{Current year net sale}}{\text{Last year net sale}} - 1 \end{aligned} \quad (6)$$

$$\begin{aligned} \text{Research and Development Rate (RD)} &= \frac{\text{Research and development payment}}{\text{Net sales}} \end{aligned} \quad (7)$$

### 2.4. Research Method

This paper first conducts the descriptive statistical analysis of the research samples, and then uses the independent sample t-test to conduct the variance analysis of enterprises with or without hedging. Afterwards, the Pearson correlation analysis is performed to analyze the correlation of various variables to eliminate the collinearity of the regression model. Finally, logistic regression analysis is employed to test the hedging by using financial derivatives, the hedging purpose and the selection of hedging tools.

#### 2.4.1. Logistic Regression Analysis

Logistic regression model's explanatory variable is a nominal scale variable of discontinuity. In addition to testing the explanatory power of the explanatory variable to the explained variable, it can observe the explanatory power of individual explanatory variable against the explained variable.

The dependent variable of this study is the use of financial derivative for hedging with 1 standing for use and 0 representing no use of financial derivatives. This is a discontinuous binary variable that is not suitable for general linear regression model. This paper employs the logistic model for discussion and analysis.

As this paper aims to discuss the effects of financial factors on the use of financial derivatives in listed and OTC enterprises in Taiwan, it sets the logistic regression analysis model with virtual variables to test whether major financial variables affect company hedging. The empirical model of this study is as shown below:

Model I: with or without using financial derivatives for hedging

$$Y_{it} = \alpha + \beta_1 DEB_{it} + \beta_2 TIE_{it} + \beta_3 OM_{it} + \beta_4 MS_{it} + \beta_5 OI_{it} + \beta_6 GW_{it} + \beta_7 RD_{it} + \varepsilon_{it} \quad (8)$$

where  $i = 1, 2, 3, \dots, n$  enterprises,  $t = \text{January, 2007 to December 2011}$  (half a year, a total of 9 terms).

$Y$  denoted the virtual variable of the use of financial derivative transaction by the company with 0 representing no use of financial derivatives and 1

representing the use of financial derivatives. DEB denoted debt ratio; TIE denoted interest coverage times; OM denoted the operating margin; MS denoted managerial shareholding percentage; OI denoted operating income; GW denoted income growth rate; RD denoted research and development rate.

2.4.2. *Multinomial logistic regression analysis*

This paper also discusses how enterprises use different financial derivatives to avoid different risks and the covariance relationship arising from the use of different hedging tools and hedging effectiveness. Since the dependent variables are of multiple choices, this paper uses the multinomial logistic model as the analysis tool. In theory, this model inherits the characteristics of the logistic model to test the relationship between the occurrence probability of the dependent variables and the explanatory variables. The difference is that the dependent variable of the logistic model is dichotomy (0 and 1) while the dependent variable of multinomial logistic is of multiple categories (0, 1, 2, 3, 4 ... ..). In this model, the dependent variables include the types of risks and types of hedging tools used by the company during the period of the empirical study.

Model II: the selection of hedging tools

$$HT_{it} = \alpha + \beta_1 DEB_{it} + \beta_2 TIE_{it} + \beta_3 OM_{it} + \beta_4 MS_{it} + \beta_5 OI_{it} + \beta_6 GW_{it} + \beta_7 RD_{it} + \varepsilon_{it} \quad (9)$$

where  $i = 1, 2, 3, \dots, n$  enterprises,  $t = \text{January, 2007 to December 2011}$  (half a year, a total of 9 terms).

Y=classification by types of hedging tools:

This paper divides the samples into four types, enterprises without using hedging tools are represented by 0, enterprises using Future are represented by 1, enterprises using Option are represented by 2, enterprises using Change are represented by 3, enterprises using Others are represented by 4.

In Model II, all the financial variables are input into the model to determine the effects of financial variables on the selection of hedging tools. The major financial variables include: DEB is the debt ratio, TIE is the interest rate coverage times, OM is the operating margin, representing the debt level and financial crisis cost of the company; MS is the managerial shareholding percentage representing the company's agency problem; OI is the net operating income, representing the company size; GW is revenue growth rate, RD is the research and development rate, representing the opportunity of growth investment of the company.

3. Empirical Results and Analysis

3.1. *Pearson Correlation Analysis*

When the coefficient  $r=1$ , it indicates a perfect positive correlation; when the coefficient  $r = -1$ , it indicates a perfect negative correlation; when  $r = 0$ , it indicates no correlation. In case of a general study, when the coefficient  $r$  is in the range of 0-0.4, it indicates a low level correlation; when the coefficient  $r$  is in the range of 0.4-0.7, it indicates a medium level of correlation; if the coefficient  $r$  is in the range of 0.7-1, it indicates a high correlation.

The correlation coefficients of all variables in Table 4 are lower than 0.7, hence all the variables are incorporated in the logistic regression analysis model.

Table 4. IC Industry Pearson Correlation Analysis

	DEB	TIE	OM	MS	OI	GW	RD
DEB	1						
TIE	-0.050	1					
OM	-0.477**	0.041	1				
MS	0.208**	-0.065	0.109**	1			
OI	0.013	-0.011	0.032	-0.178**	1		
GW	-0.029	0.043	0.111**	0.246**	-0.002	1	
RD	-0.269**	0.001	0.156**	0.176**	-0.148**	-0.092*	1

\*, \*\*, and \*\*\* represent statistical significance at the 10%, 5%, and 1% level, respectively

As shown in Table 5, the correlation coefficients of GW and OM are above 0.7, hence, OM

is deleted and the rest variables are incorporated in the Logistic regression analysis model.

Table 5.

VI Model Pearson Correlation Analysis

	DEB	TIE	OM	MS	OI	GW	RD
DEB	1						
TIE	-0.200	1					
OM	-0.639**	0.139	1				
MS	0.282*	-0.104	0.050	1			
OI	0.116	-0.038	0.173	0.220	1		
GW	-0.453**	0.096	0.912**	0.167	0.191	1	
RD	0.131	0.024	-0.102	0.476**	0.645	-0.159	1

\*, \*\*, and \*\*\* represent statistical significance at the 10%, 5%, and 1% level, respectively

The correlation coefficients of all variables in Table 6 are lower than 0.7, hence, all the variables are incorporated in the logistic regression analysis model.

Table 6.

IDM Model Pearson Correlation Analysis

	DEB	TIE	OM	MS	OI	GW	RD
DEB	1						
TIE	-0.039	1					
OM	-0.234**	0.036	1				
MS	0.235**	-0.075	0.161**	1			
OI	-0.039	-0.008	0.098*	-0.247**	1		
GW	0.021	0.041	0.014	0.279**	-0.002	1	
RD	-0.290**	-0.002	0.230**	0.167**	-0.148**	-0.098*	1

\*, \*\*, and \*\*\* represent statistical significance at the 10%, 5%, and 1% level, respectively

### 3.2. Logistic Regression Analysis

The Taiwan's IC industry's logistic regression analysis results are as shown in Table 7. The factors

affecting the use of financial derivatives for hedging include: DEB, OM, MS, OI, RD.

Table 7.

IC Industry Logistic Regression Analysis

Hypothesis	Variables	Beta	Sign.
1	DEB	0.028**	0.015
	TIE	0.000	0.623
	OM	-0.017***	0.001
2	MS	0.040**	0.025
3	OI	0.000***	0.000
4	GW	-0.001	0.767
	RD	-0.046*	0.085

\*, \*\*, and \*\*\* represent statistical significance at the 10%, 5%, and 1% level, respectively

The logistic regression analysis results of the virtual integration of Taiwan's IC industry as shown in Table

8. The factors affecting the use of financial derivatives by the company include: DEB、MS、OI、GW

Table 8. VI Model Logistic Regression Analysis

Hypothesis	Variables	Beta	Sign.
1	DEB	0.059**	0.042
	TIE	-0.004	0.785
2	MS	0.066*	0.050
3	OI	0.000***	0.001
4	GW	-0.015***	0.009
	RD	-0.007	0.922

\*, \*\*, and \*\*\* represent statistical significance at the 10%, 5%, and 1% level, respectively

The logistic regression analysis results of the vertical integration of Taiwan's IC industry are as shown

in Table 9. The factors affecting the use of financial derivatives by the company include: OI、RD。

Table 9. IDM Model Logistic Regression Analysis

Hypothesis	Variables	Beta	Sign.
1	DEB	0.021	0.217
	TIE	0.000	0.674
	OM	0.013	0.394
2	MS	-0.044	0.264
3	OI	0.000**	0.013
4	GW	-0.001	0.872
	RD	-0.140**	0.016

\*, \*\*, and \*\*\* represent statistical significance at the 10%, 5%, and 1% level, respectively

### 3.3. Multinomial Logistic Regression Analysis

My study classifies derivatives as four types: Future, Option, Change, Others. According to my study Future is most used in IC Industry, then Change,

Others, Option is the least used one. In IDM model, Change is most used, then Option, Future and Others. In VI model, Future is the most used one, and then Others, Change, Option are liked respectively

Table 10. IC Industry Multinomial Logistic Regression Analysis

Hedge product	Futures (102)		Option (54)		Change (98)		Others(86)	
	Beta	Sign.	Beta	Sign.	Beta	Sign.	Beta	Sign.
Intercept	-2.427	0.000	-5.068	0.000	-3.527	0.000	-2.937	0.000
DEB	0.010	0.268	0.052*	0.000	0.028*	0.005	0.021*	0.038
TIE	0.000*	0.068	0.000	0.539	0.000	0.394	0.000	0.153
OM	0.004	0.537	0.000	0.968	-0.006	0.215	0.016*	0.015
MS	-0.014	0.433	0.024	0.283	0.011	0.526	-0.028	0.202
OI	0.000*	0.000	0.000*	0.000	0.000*	0.000	0.000*	0.000
GW	-0.001	0.786	-0.007	0.176	-0.001	0.818	-0.004	0.305
RD	0.007	0.450	-	0.021	-0.018	0.291	-0.015	0.313
			0.087**					

\*, \*\*, and \*\*\* represent statistical significance at the 10%, 5%, and 1% level, respectively

Table11. VI Model Multinomial Logistic Regression Analysis

Hedge product	Future(19)		Option(29)		Change(33)		Others(9)	
	Beta	Sign.	Beta	Sign.	Beta	Sign.	Beta	Sign.
Intercept	-5.672	0.019	-8.017	0.003	-8.330	0.001	-8.411	0.005
DEB	0.044	0.215	* 0.069	0.052	** 0.079	0.015	** 0.126	0.030
TIE	-0.002	0.825	-0.003	0.701	0.000	0.969	0.000	0.964
OM	-0.007	0.798	0.042	0.188	-0.002	0.910	0.022	0.567
MS	0.029	0.652	* 0.083	0.097	** 0.102	0.041	0.056	0.523
OI	* 0.000	0.074	** 0.000	0.028	** 0.000	0.030	0.000	0.298
GW	-0.001	0.976	-0.049	0.118	-0.005	0.791	0.013	0.622
RD	0.015	0.879	0.014	0.878	-0.006	0.945	0.066	0.753

\*, \*\*, and \*\*\* represent statistical significance at the 10%, 5%, and 1% level, respectively

Table12. IDM Model Multinomial Logistic Regression Analysis

Hedge product	Future(83)		Option (25)		Change(65)		Others(77)	
	Beta	Sign.	Beta	Sign.	Beta	Sign.	Beta	Sign.
Intercept	-2.616	0.000	-3.474	0.002	-2.562	0.000	-2.619	0.000
DEB	0.006	0.564	** 0.059*	0.007	* 0.029*	0.038	0.022*	0.064
TIE	0.000*	0.094	0.000	0.645	0.000	0.365	0.000	0.200
OM	** 0.028*	0.001	* 0.037*	0.031	0.009	0.548	** 0.031*	0.001
MS	-0.033	0.143	-0.089*	0.099	-0.065*	0.050	-0.069**	0.018
OI	** 0.000*	0.002	0.000*	0.084	** 0.000*	0.000	** 0.000*	0.000
GW	0.000	0.964	-0.008	0.303	-0.003	0.513	-0.007	0.139
RD	-0.002	0.837	-0.479**	0.020	-0.032	0.184	-0.025	0.149

\*, \*\*, and \*\*\* represent statistical significance at the 10%, 5%, and 1% level, respectively

3.3.1. *Future*

3.3.2. My study finds that Taiwan IC industry's multinomial logistic regression analysis results are as shown in Table 10. The factors affecting the use Future for hedging consist of TIE and OI, both of them are positive correlation significantly. Virtual integration's multinomial logistic regression analysis results are as shown in Table 11. The factors affecting the use Future for hedging include TIE, OI and OM which are significant positive correlation. Vertical integration's multinomial logistic regression analysis results are as shown in Table 12. The factor affecting the use Future for hedging includes only OI. Therefore, I conjecture that using Future may be related to financial crisis and company size.

3.3.3. *Option*

The study shows Taiwan IC industry's multinomial logistic regression analysis results in Table 10. The factors affecting the use Option for hedging include DEB and OI which are significantly positive correlation. Virtual integration's multinomial logistic regression analysis results are as shown in Table 11. The factors affecting the use Option for hedging consist of DEB, MS and OI which are positive correlation significantly as well. In contrast, in vertical integration business model, the factors of MS and RD are significant negative correlation with Option shown in table 12.

3.3.4. *Change*

According to tables 10, 11, 12, factors DEB and OI are significant positive correlation in all models from the results of multinomial logistic regression. Meanwhile, MS factor is correlated differently with Change in Virtual integration and vertical integration

models. If in Virtual integration model, MS is significant positive correlation, in vertical integration model shows negative correlation significantly.

3.3.5. *Others*

In whole IC industry where various derivatives are used simultaneously as factors for hedging, DEB, OM and OI variables are significant positive correlated. Only DEB shows positive correlation significantly in virtual integration model as table 11. In vertical integration model, the factors for hedging including DEB, OM and OI are positive correlated significantly, oppositely, only MS are negative correlated significantly.

**4. Empirical Results and Suggestions**

In many domestic and foreign previous researches, it is found that the awareness of financial crisis and company's characteristics will help them to decide which types of hedging instruments. In summary of the empirical results from above tables, there are different correlation between hedge products and variables in two business models for the Taiwan IC Industry as shown in table 14. In virtual integration model, Futures has significant positive correlation with only OI and all of Options, Change and other hedging instruments have also significant positive correlation with DEB, MS and OI. In vertical integration model, Futures hedging activities are positive correlated significantly with TIE, OM, OI. Besides, in correlation with Option and other hedging tools, DEB, OM and OI are significantly positive but MS is significantly negative. In addition, with Change, DEB, OI and MS are significantly correlated but only MS is negative.

Table 14.  
Two Business models Comparison

	VI (left) & IDM (right)							
	Future		Option		Change		Other	
DEB			+	+	+	+	+	+
TIE		+						
OM		+		+				+
MS			+	-	+	-	+	-
OI	+	+	+	+	+	+	+	+
GW								
RD				-				

+ mean Positive correlation, - means Negative correlation



In conclusion, with the companies applied virtual integration model having higher level of DEB, MS and OI, they should use Option and Change as hedging instruments. Meanwhile, with the companies applied vertical integration model, they may have more advantage if they choose Option and Change derivatives to hedge at the higher level of DEB. or at the lower level of MS which is opposite to the virtual integration model.

This study is expected to provide a deep understanding of relationship between financial derivatives and business operations of enterprises for investors, governmental authorities, and policy makers as a basic reference in making decision of hedging instruments.

## References

- [1] P.R. Krugman and M. Obstfeld, International economics: Theory and policy, New York: Addison Wesley (2006).
- [2] F. Modigliani and H.M. Miller, The cost of capital, corporation finance and the theory of investment, *American Economic Review* 48 (3) (1958) 261-297.
- [3] C.W. Smith and R.M. Stulz, The determinants of firms' hedging policies, *Journal of Financial and Quantitative Analysis* 20 (4) (1985) 391-405.
- [4] J.R. Graham and D.A. Rogers, Do firms hedge in response to tax incentives? *Journal of Finance* 57 (2) (2002) 815-839.
- [5] H. Berkman and M.E. Bradbury, Empirical evidence on the corporate use of derivatives, *Financial Management* 25 (2) (1996) 5-13.
- [6] A. Purnanandam, Interest rate derivatives at commercial banks: An empirical investigation, *Journal of Monetary Economics* 54 (6) (2007) 1769-1808.
- [7] A. Purnanandam, Financial distress and corporate risk management: Theory and evidence, *Journal of Financial Economics* 87 (3) (2008) 706-739.
- [8] M. Campello, C. Lin, Y. Ma and H. Zou, The real and financial implications of corporate hedging, *The Journal of Finance* 66 (5) (2011) 1615-1647.
- [9] L.A.F. Carneiro and M. Sherris, Corporate interest rate risk management with derivatives in Australia: Empirical results, *Revista Contabilidade and Finanças* 19 (46) (2008) 86-107.
- [10] H. Bessembinder, Forward contracts and firm value: Investment incentive and contracting effects, *Journal of Financial and Quantitative Analysis* 26 (4) (1991) 519-532.
- [11] K.A. Froot, D.S. Scharfstein and J.C. Stein, Risk management: Coordinating corporate investment and financing policies, *Journal of Finance* 48 (5) (1993) 1629-1658.
- [12] Y. Amihud, J.Y. Kamin and J. Ronen, 'Managerialism', 'ownerism' and risk, *Journal of Banking and Finance* 7 (2) (1983) 189-196.
- [13] C. Géczy, B.A. Minton and C. Schrand, Why firms use currency derivatives, *Journal of Finance* 52 (4) (1997) 1323-1354.
- [14] J. Supanvanij and J.K. Strauss, The effects of management compensation on firm hedging: Does SFAS 133 matter? *Journal of Multinational Financial Management* 16 (5) (2006) 475-493.
- [15] S. Hsu, P.S. Ko, C.C. Wu, S.R. Cheng and Y.S. Chen, Hedging with derivatives by Taiwanese listed non-financial companies, *International Journal of Electronic Finance* 3 (3) (2009) 211-234.
- [16] L. Fauver and A. Naranjo, Derivative usage and firm value: The influence of agency costs and monitoring problems, *Journal of Corporate Finance* 16 (5) (2010) 719-735.
- [17] S.B. Block and T.J. Gallagher, The use of interest rate futures and options by corporate financial managers, *Financial Management* 15 (3) (1986) 73-78.
- [18] M. Boyer, M.M. Boyer and R. Garcia, The value of real and financial risk management, *Scientific Series, CIRANO* 38 (2005).
- [19] J.M.E. Pennings and P. Garcia, Hedging behavior in small and medium-sized enterprises: The role of unobserved heterogeneity, *Journal of Banking and Finance* 28 (5) (2004) 951-978.
- [20] J.F. Sinkey Jr. and D.A. Carter, Evidence on the financial characteristics of banks that do and do not use derivatives, *Quarterly Review of Economics and Finance* 40 (4) (2000) 431-449.
- [21] S.C. Chang, J.H. Lai and Y.P. Huang, The

motives of corporate use of derivatives: Evidence from Taiwan, *Sun Yat-Sen Management Review* 12 (S2) (2003) 1-18.

[22] A. Judge, Why and how UK firms hedge, *European Financial Management* 12 (3) (2006) 407-441.

[23] D. Carter, D.A. Roger and B.J. Simkins, Hedging and value in the U.S. airline industry, *Journal of Applied Corporate Finance* 18 (4) (2006) 21-33.

[24] Shuofen et al P. Tufano, Who manages risk? An empirical examination of risk management practices in the gold mining industry, *Journal of Finance* 51 (4) (1996) 1097-1137.

[25] G.D. Gay, C.M. Lin and S.D. Smith, Corporate derivatives use and the cost of equity, *Journal of Banking and Finance* 35 (6) (2011) 1491-1506.

[26] R. Dhawan, Firm size and productivity differential: Theory and evidence from a panel of US firms, *Journal of Economic Behavior and Organization* 44 (3) (2001) 269-293.

[27] D. Gale and M. Hellwig, Incentive-compatible debt contracts: The one-period problem, *Review of Economic Studies* 52 (4) (1985) 647-663.

[28] K.M. Klimczak, Corporate hedging and risk management theory: Evidence from Polish listed companies, *Journal of Risk Finance* 9 (1) (2008) 20-39.

[29] C.W. Fok, C. Carroll and M.C. Chiou, Determinants of corporate hedging and derivatives: A revisit, *Journal of Economics and Business* 49 (6) (1997) 569-585.

[30] D. Haushalter, S. Klasa and W.F. Maxwell, The influence of product market dynamics on a firm's cash holdings and hedging behavior, *Journal of Financial Economics* 84 (3) (2007) 797-825.

[31] S.M. Bartram, G.W. Brown and F.R. Fehle, International evidence on financial derivatives usage, *Financial Management* 38 (1) (2009) 185-206.

[32] H. Nguyen and R. Faff, On the determinants of derivative usage by Australian companies, *Australian Journal Management* 27 (1) (2002) 1-24.

**Dr. Shu-Shian Lin** is Assistant Professor of Department of International Business Administration,

Chinese Culture University and holds Ph.D. in National Central University. His papers appeared in *Applied Financial Economics Letter*, *African Journal of Business Management*, and others.

**Dr. Yi-Hsien Wang** is Associate Professor of Department of Banking & Finance, Chinese Culture University and holds Ph.D. in the Graduate School of Management, Ming Chuan University. His current research interests are in the area of International Business, Financial Management, Decision Science and Financial Time Series. His papers appeared in *Annals of Economics and Finance*, *Applied Economics*, *Hitotsubashi Journal of Economics*, *Applied Economics Letters*, *International Journal of Computer Mathematics*, *Quality & Quantity*, *Zagreb International Review of Economics and Business*, *Romanian Journal of Economic Forecasting*, *Economic Modelling*, *Journal of Business Economics and Management* and others.

**Mr. Ping-Hui Huang** is Undergraduate student of Department of Banking & Finance, Chinese Culture University.

## Using Multinomial Logistic Model to Evaluate Hedge Effect in the Information Technology Industry

Yi-Hsien Wang <sup>a\*</sup> Jung-Ho Lu <sup>b</sup> Hwa-Rong Shen <sup>c</sup> Rui-Lin Tseng <sup>a</sup>

<sup>a</sup> Dept. Banking and Finance, Chinese Culture University, Taipei, Taiwan

<sup>b</sup> Dept. Risk Management and Insurance, Ming Chuan University, Taipei, Taiwan

<sup>c</sup> Dept. Applied Finance, Yuanpei University, Taipei, Taiwan

\* Author for correspondence, e-mail: [holland@mail2000.com.tw](mailto:holland@mail2000.com.tw)

### Abstract

Subject to the increase of the liberalization of markets, the business performance is significantly related to the market risk. Therefore, the company usually utilized high financial leverage of derivatives to hedge the risk. This study examines whether hedge effect exists in the information technology industry. Empirical results of this study provide a diacritical opinion for investors that there is no need to overestimate the hedge effect. The research findings can be a basis reference for investors in decision-making.

Keywords: Hedge, Derivatives, Exchange rate risk, Information industry

### 1. Introduction

Many financial derivatives based on equity securities, bonds or relevant financial instruments are continuously emerging in today's increasingly open and free financial market. Such financial derivatives, including forward contracts, futures, swaps, and options, have diversified financial commodities and provided investors more options of hedge venues. The financial derivatives started to circulate in 1994. Then derivatives were not required public disclosure of details concerning the use of derivatives by the company, which is different from general accounting practice. In 1996, the Securities and Futures Management Commission, Ministry of Finance officially announced the "Points of Note on Disclosure of Financial Reports Regarding Financial Derivatives Trading by Listed Enterprises" to protect general investors. Since then, enterprises engaged in trading financial derivatives are required to compile financial reports to disclose information in the categories of

"trading purposes" and "non-trading purposes". The non-trading purposes refer to the purpose of hedging. The information disclosure should be explained in the notes to the financial reports.

Taiwan's economy is mainly export-driven. Since 1970s, countries have implemented the floating exchange rate system, and the fluctuations in exchange rate have an enormous impact on the export prices of the enterprises (Alkebäck and Hagelin, 1999). The fluctuations in exchange change will result in decrease or increase in settlements of the trading between enterprises, indirectly affecting the shareholder interests. Hence, enterprises may avoid the system risk of exchange rate by buying or selling financial derivatives. The control of exchange rate risk has become an increasingly important and valued subject for enterprises.

The output of Taiwan's information industry has occupied the pivotal part in global market. Most of the literature about Taiwan's information industry development focuses on the relationship between internationalization level and corporate governance, the motivations and strategies for the internationalization of the information industry, the globalized functional relationships in the information industry, or explores the employees and organizational core functions in the information industry (Conyon and Peck, 1998; Zald, 1969; Supanvanij and Strauss, 2006; Mian, 1996). Enterprises having larger size and greater financial crisis costs will be more likely to use financial derivatives for hedging. Particularly, the electronics industry is more proactive in using financial derivatives trading for hedging than other industries (Venkatachalam, 1996). Regardless of the electronics or the non-electronics industries, investors will partially use the contract amount. (Allayannis and Qfek, 2001; Guay and Kothari, 2003) found that exchange rate risk and the use of derivatives are considerably correlated. The information economies of

scale effects of hedging can also be identified (Block and Gallagher, 1986). The operations of hedging financial derivatives are complex and require manpower to process relevant information in real time. This indicates that enterprises of large scale are more likely to use financial derivatives for hedging, and are more engaged in hedging activities (Berkman and Bradbury, 1996). In summary, the above literature mainly discusses the use of financial derivatives in electronics industry. Few discussions on the relevance of information industry and the use of financial derivatives in the background of economic cycle have been made in the past. Hence, it is worth to be reviewed and studied in the present.

This paper probes into the relevance and significant level of using financial derivatives in the long economic development process of alternating active periods and downturn periods by the upstream, middle stream and downstream manufacturers in the information industry, who are facing to exchange rate risks? The problems discussed are as follows: What are the hedge factors that affect the use of financial derivatives of enterprises in the information industry in Taiwan? Are there any differences in hedge factors of engaging in financial derivatives trading of enterprises in the information industry in Taiwan when they face types of risks and use hedging tools? In the business cycle, is there any significant relevance between manufacturers in different positions of the supply chain of the information industry? This paper uses the logistic model to verify the relationships among the use of financial derivatives to avoid risks from different sources, the selection of hedging tools and major financial variables in case of the information industry in Taiwan. The multinomial logistic is applied to understand whether the use of financial derivatives for hedging is effective or of poor effect or without significant effects.

## 1. Literature Review

Financial derivatives refer to financial products that are derived from spot markets of foreign exchange, securities, stocks and short term bills. Financial derivative is a financial tool or contract, and its value is subject to the value of the target asset or other indicators (stock price index, consumer price index) as determined by the buyer and the seller. The common financial derivatives in Taiwan are forward contracts, future contracts, options and swaps as four types of basic hedging tools (Lien, 2006). Due to its high financial leverage, high returns and high risks, enterprises often use financial derivatives as hedging

tools. The so-called hedging refers to protect the current assets by using a temporary investment target or transfer market risks to investors who are willing to bear such risks by foreign exchange rate, interest rate or commodity price.

The corporate hedging demand derived from the company size, risk exposure extent or financial risk or company's growth investment opportunity variables or financial price fluctuations. Changes in financial prices not only affect the earnings in the financial statements of the company, but also affect the survival of the company. Hence, enterprises will protect financial position through hedging policies, and further enhance the current value of the company. Below is the review of the literature on the company's hedging motivations as proposed by scholars at home country and in abroad.

In case of separated ownership and business management rights, it may result in conflicts between shareholders and the management, which may lead to discrepancy in company's decision-making policies (Friend and Hasbrouck, 1987). By using financial derivatives to maximize the shareholder interests, it can effectively reduce the agency problem. (Fok et al., 1997) argued that hedging can lower agency costs and increase shareholder value.

Based on the information economies of scale viewpoints, large enterprises have more economies of scale benefits than small ones. Hence, large enterprises are capable of inviting professional managers to execute financial derivatives, and develop more perfect hedging plans (Booth, Smith and Stolz, 1984; Block and Gallagher, 1986). Comparatively, in order to avoid expensive external fund raising transaction costs, small enterprises will tend to implement more risk management behaviors (Tufano, 1996; Graham and Roger, 2002; Carter, Rogers and Simkins, 2006).

The company's operating characteristics and the extent of risk exposure will affect the company in the use of financial derivatives (Berkman and Bradbury, 1996). The company's business strategy, corporate culture, and the ratio of foreign sales will affect the extent of foreign exchange exposure. The risk exposure level will affect the level of using financial derivatives by the company. When the company is engaged in international trading or has overseas business offices, the fluctuations in foreign exchange rate will affect the value of the company. Hence, if the company's foreign exchange risk exposure is greater, the fluctuations in corporate value will be more significant. Hence, the company will use financial derivatives to mitigate the risk of exchange rate (Markar and Huffman, 1997).

Financial crisis refers to the threat of bankruptcy that the enterprise is facing when it cannot perform the obligation of debt settlement. In terms of corporate capital structure, enterprises of high debt ratio are more prone to financial crises. As a result, when the enterprise is under more pressure of financial crisis, it will strengthen the use of financial derivatives to reduce the occurrence probability of financial crisis (DeMarzo and Duffie, 1991).

Investment opportunity is an option to the company. The implementation of investment plans are determined by investment returns. If most of the benefits of certain investment have to be paid to the creditors rather than shareholders, the shareholders will be very likely to abandon the investment plan, resulting in the problem of insufficient investment (Myers, 1977; Chang, 2000). When a company has more growth investment opportunities, it is more likely to face the problem of insufficient investment and more likely to use financial derivatives for hedging to reduce cash flow volatility (Lin and Smith, 2007; Nance et al. 1993).

## 2. Research Method and Procedures

With listed companies in the information industry in Taiwan Stock Exchange during the period from January 2007 to June 2011 as the research subject, this paper divides the research period into 9 intervals of half a year each, this paper explores the type of financial derivative that should be selected at various stages in the business cycle, and how to use the characteristics of such financial derivatives to avoid foreign exchange rate risk and risks arising from other factors. This paper has eliminated enterprises of the non-information industry, enterprises with omissions of requested variables, enterprises of incomplete financial information or enterprises that have been merged or

delisted due to financial crisis during the research period. According to the above selection standards, this paper selects a total of 344 sample companies. The data are sourced from the prospectuses of these Taiwanese listed companies, the companies' annual reports, and the CMoney institutional investment decision-making support system.

### 3.1. Variables

(1) Measurement Variables of Company Size

$$\text{Operating income (OI)} = \frac{\text{net operating income}}{\text{net operating income}} \quad (3.1)$$

(2) Measurement Variables of Risk Exposure Level

$$\text{Ratio of Foreign Sales (FS)} = \frac{\text{foreign sales}}{\text{net operating income}} \quad (3.2)$$

(3) Measurement Variables of Financial crisis variables

$$\text{Ratio of Debt (DEB)} = \frac{\text{Debt}}{\text{net operating income}} \quad (3.3)$$

$$\text{Interest Coverage Ratio (TIE)} = \frac{\text{EBIT}}{\text{Interest Tax}} \quad (3.4)$$

$$\text{Operating Margin (OM)} = \frac{\text{Gross Profit}}{\text{Net Sales}} \quad (3.5)$$

(4) Measurement Variables of Company's growth investment opportunity variables

$$\text{Growth Rate (GR)} = \frac{\text{this year net sale}}{\text{Last year sale}} - 1 \quad (3.6)$$

$$\text{Research and Development Rate (RD)} = \frac{\text{Research and Development payment}}{\text{Net sales}} \quad (3.7)$$

Table 1 Summary of Measurement Variables

Research Dimensions	Variables	Code	Definition Variables
Company size	Net Operating Income	OI	Annual net operating income
Risk exposure extent	Ratio of Foreign Sales	FS	Foreign sale volume/net operating income
Financial crisis	Ratio of Debt	DEB	(Operating profit + depreciation) / net
	Interest Coverage Ratio	ICR	EBIT/Interest tax
	Operating Margin	OM	Gross Profit/ Net Sales

Table 1 Summary of Measurement Variables

Research Dimensions	Variables	Code	Definition Variables
Company's growth investment opportunity variables	Growth Rate	GR	(This year net sale /Last year sale)-1
	Research and development Rate	RD	Research and development Payment / Net Sales

stages of business cycle of listed enterprises of the information technology industry. The empirical model of this study is as below:

$$Y_i = \alpha_0 + B_1X_1 + B_2X_2 + B_3X_3 + B_4X_4 + B_5X_5 + B_6X_6 + B_7X_7$$

### 3.2. Research Method

This research is divided into four parts: the first, an introduction of the general survey of using financial derivatives at various stages of business cycle by the listed enterprises of the information technology in Taiwan; the second, using the Pearson correlation analysis to analyze the correlations of various variables and exclude the co-linearity of the regression model. Next, Logistic regression analysis is used to discuss the exchange rate risk avoidance of the company. Finally, the Multi-nominal Logistic model is used to discuss the whether the selection of financial derivatives can effective help the company in avoiding exchange rate risk.

#### (1) Pearson correlation coefficient

Prior to the regression analysis, the existence of co-linearity between independent variables should be checked as it may reduce the capability of the explanatory variables and affect the effectiveness of the regression model. The basic properties of the coefficient are: when the coefficient is 1, it indicates a positive complete correlation; when the coefficient is -1, it indicates a complete negative correlation; when the coefficient is in the range of 0.4-0.6, it indicates a medium level correlation; if the coefficient is in the range of 0.6-1, it indicates a high correlation.

#### (2) Logistic Regression Analysis

The dependent variable of this paper is the use of financial derivative for hedging with 1 denotes use and 0 denotes no use of financial derivatives. This is a discontinuous binary variable that is not suitable for general linear regression model. This paper employs the logistic model to discuss the determining factors affecting the use of financial derivatives at various

Logistic regression analysis is used to test the relationship between the probability of the occurrence of the explained variables and the various measureable variables. The explanatory variables of the Logistic model are interrupted nominal scale variables. In addition to testing the explanatory power of the explanatory variables to the explained variables, it can observe the explanatory power of a single variable to the explained variable when other explanatory variables are not changed. Dependent variable  $Y_i$  is the virtual variable for the use of financial derivative trading by the  $i$ th company. It is 0 in case of enterprises having used the financial derivatives trading and is 1 in case of enterprises using the trading of financial derivatives. Independent variable  $BC1$  refers to the various stages of the business cycle.  $BC1$  denotes the peak of the business cycle and  $BC2$  denotes for the downturn period of the business cycle;  $BC3$  is the valley of the business cycle;  $BC4$  is the recovery period of the business cycle. When  $BC1$ ,  $BC2$ ,  $BC3$ ,  $BC4$  are not 0, it is a period of booming business cycle. In addition, when operating hedging derivatives, the explanatory variables under exchange rate risks include: net operating income (OI), ratio of foreign sales (FS), ratio of debt (DEB), interest coverage ratio (ICR), operating margin (OM), growth rate (GR), research and development rate (RD).

#### (3) Multinomial Logistic Regression Analysis

This paper also discusses how enterprises use different financial derivatives to avoid different risks and the covariance relationship arising from the use of different hedging tools and hedging effectiveness. Since the dependent variables are multiple choices, the multinomial logistic model is used as the analysis tool. In theory, this model inherits the characteristics of the

logistic model to test the relationship between the occurrence probability of the dependent variables and the explanatory variables. The difference is that the dependent variable of the logistic model is dichotomy (0 and 1) while the dependent variable of Multinomial Logistic is multiple categories (0, 1, 2, 3, 4 ... ..). In this model, the dependent variables include the types of risks and types of hedging tools used by the company during the period of the empirical study. The empirical model of this study is as follows:

$$HT_i = \alpha_0 + B_1X_1 + B_2X_2 + B_3X_3 + B_4X_4 + B_5X_5 + B_6X_6 + B_7X_7$$

The research samples are categorized into four types including hedging by using futures tools, hedging by using swaps, hedging by using options, hedging by using other tools. Other classification methods regard the use of more than two of the above three hedging tools as other method of hedging. All the financial variables are input in the model to judge the significance of the help to the company of the

effectiveness of using the hedging tools by the company.

### 3. Empirical Results

#### 3.1. Pearson correlation coefficient

This paper uses Pearson correlation coefficient to test the correlation level of variables. In general, correlation coefficient  $r$  is used to determine the correlation level of two variables. The basic properties of the coefficient are: when the coefficient is 1, it indicates a positive complete correlation; when the coefficient is -1, it indicates a complete negative correlation; when the coefficient is in the range of 0.4-0.6, it indicates a medium level correlation; if the coefficient is in the range of 0.6-1, it indicates a high correlation. Table 2 illustrates the Pearson correlation relationship analysis results, suggesting that the correlation coefficients of all variables are lower than the standard of 0.6; therefore, all the variables are incorporated in the model of logistic regression analysis.

Table 2 Pearson correlation coefficient

	OI	FS	DEB	ICR	OM	GR	RD
OI	1						
FS	* 0.097*	1					
DEB	* 0.170*	-0.026	1				
ICR	-0.005	0.002	- 0.084**	1			
OM	- 0.075**	- 0.082**	- 0.392**	* 0.100*	1		
GR	0.013	-0.030	0.014	0.026	* 0.052*	1	
RD	- 0.065**	-0.018	- 0.257**	0.043*	* 0.297*	- 0.065**	1

\* Correlation is significant at the 0.05 level (2-tailed);

\*\* Correlation is significant at the 0.01 level (2-tailed)

#### 4.2. Logistic regression analysis

Table 3 illustrates the results of the logistic regression analysis of the information technology industry in Taiwan. As seen, factors

affecting the use of financial derivatives for hedging by enterprises include OI, FS, DEB, TIE, OM, GR, and RD.



Table 3 Logistic regression analysis

Research Dimensions	Variables		
		Coefficient	p-value
1.	OI	0.000***	0.000
2.	FS	0.005***	0.001
3.	DEB	0.008***	0.010
	ICR	0.000***	0.003
	OM	0.000***	0.001
4.	GR	0.000	0.753
	RD	-0.015**	0.041

\* is significant at the 0.1 level; \*\* is significant at the 0.05 level; \*\*\* is significant at the 0.01 level

By Logistic regression analysis, it is found that hedging and net business income are positively correlated. In other words, companies of larger size enjoy more scale of economies advantage in hedging cost, and thus, the possibility of exchange rate hedging is higher.

It is found by the regression analysis; the export ratio and hedging behavior are positively significantly correlated. Hence, the higher export ratio means higher probability of exchange rate hedging.

The empirical results suggest that debt ratio, interest coverage ratio, and gross profit rate are

significantly correlated to exchange rate risk hedging. This suggests, when the debt ratio is higher, the management is more likely to take active exchange rate risk hedging behaviors.

Growth investment opportunities: the regression results suggest that regarding the relationship between the company's revenue growth rate, R&D expenditure ratio and the exchange rate risk hedging, the R&D expenditure ratio regression analysis result is not significant, and the regression result of the revenue growth rate is not significant. The results are not as expected.

#### 4.3. Multinomial Logistic Model

Due to the increasing level of liberalization and fast development of the financial market in recent years, the effectiveness of business operations of the enterprises are often closed related to the market

Table 4 Multinomial Logistic Model

risk. By using the Multinomial Logistic model, this paper empirically explores the relationship between the selection of different types of hedging instruments and various types of risk as well as compares the significance.

		$\beta$	p-value
Futures	Intercept	-2.382	0.000
	OI	0.000***	0.000
	FS	0.002	0.120
	DEB	0.006*	0.089
	ICR	0.000***	0.001
	OM	0.012***	0.001
	GR	0.000	0.575
	RD	-0.010	0.162
Options	Intercept	-3.802	0.000
	OI	0.000***	0.000
	FS	0.001	0.681
	DEB	0.026***	0.000
	ICR	0.000**	0.011

	OM	0.012**	0.013
	GR	0.000	0.826
	RD	-0.034**	0.036
<b>Swaps</b>	<b>Intercept</b>	-2.981	0.000
	OI	0.000***	0.000
	FS	0.002	0.262
	DEB	0.016***	0.001
	ICR	0.000	0.435
	OM	-0.003	0.493
	GR	0.000	0.655
	RD	-0.017	0.162
<b>Others</b>	<b>Intercept</b>	-2.803	0.000
	OI	0.000***	0.000
	FS	0.004**	0.041
	DEB	0.006	0.154
	ICR	0.000***	0.000
	OM	0.017***	0.000
	GR	-0.002	0.127
	RD	-0.019**	0.047

\* is significant at the 0.1 level; \*\* is significant at the 0.05 level; \*\*\* is significant at the 0.01 level

*The fundamental data analysis of this study finds that sample companies use futures most among all the financial derivatives, followed by other hedging tools and swaps, options and finally swap*

*According to the regression analysis, companies with larger size will have higher probability of financial crisis and higher possibility of using options for hedging. The export ratio and revenue growth rate are not significantly correlated.*

*The results of Multinomial Logistic regression analysis have suggested that, companies with larger size have higher probability of using swaps. In addition to the debt ratio of significant correlation, the results of other variables are opposite to the expectations, indicating that the effectiveness of using swaps for hedging is not significant.*

*The analysis results suggest that companies with larger size, greater export ratio and more serious financial crisis are more likely to use more than two types of hedging tools. However, the results of the debt ratio and revenue growth rate are opposite to expectations.*

## 5. Empirical Results and Suggestions

*With the openness and liberalization of today's financial markets, the enterprises can effectively perfect resource allocations by internalization. Comparatively, enterprises often face threats of exchange rate in business operation. The empirical*

*results of this study have suggested that companies with larger size, greater export cost, and financial cost will have higher chances of using financial derivatives. However, the correlation of growth investment opportunities is relatively insignificant.*

*Future studies can use longer research period and more research variables. Since this study regards more than two types of hedging tools used in the same time into one category, future studies can conduct comparative analysis by further detailing these conditions. Since this study is undergoing.*

*In the future, the variable of the macro environment of business cycle is expected to be added to explore the use of financial derivatives at various periods of the business cycle.*

## References

- [1] Alkeback, P. and Hagelin, N. 1999, Derivative Usage by Nonfinancial Firms in Sweden with an International Comparison. *Journal of International Financial Management and Accounting*, 10, 105-120.
- [2] Allayannis, G. and Ofek, E. 2001, Exchange Rate Exposure, Hedging, and the Use of Foreign Currency Derivatives. *Journal of International Money and Finance*, 20, 273-296.

- [3] Berkman, H. and Bradbury, M. E. 1996, Empirical Evidence on the Corporate Use of Derivatives. *Financial Management*, 25, 5-13.
- [4] Booth, J. R., Smith, R. L. and Stulz, R. W. 1984, The use of interest futures by financial institutions. *Journal of Bank Research*, 15, 15-20.
- [5] Block, S. B. and Gallagher, T. J. 1986, The Use of Interest Futures & Options by Corporate Financial Management. *Financial Management*, 15, 83-78.
- [6] Carter, D., Roger, D. A. and Simkins, B. J. 2006, Hedging and Value in the Airline Industry. *Journal of Applied Corporate Finance*, 18, 21-33.
- [7] Conyon, M. J. and Peck, S. I. 1998, Board control, remuneration committees, and top management compensation. *Academy of Management Journal*, 41, 146-157.
- [8] Fok, C. W., Carroll, C. and Chiou, M. C. 1997, Determinants of Corporate Hedging and Derivatives: A Revisit. *Journal of Economics and Business*, 49, 569-585.
- [9] Friend, I. and Hasbrouck, J. 1987, Determinants of Capital Structure. *Research in Finance*, 7, 1-19.
- [10] Graham, J. R. and Rogers, D.A. 2002, Is Corporate Hedging Consistent with Value Maximization? An Empirical Analysis. *Journal of Finance*, 57, 815-840.
- [11] Guay, W. and Kothari, S. P. 2003, How Much Do Firms Hedge with Derivatives? *Journal of Financial Economics*, 70, 423-461.
- [12] Lin, C. M., and Smith, S. 2007, Hedging, Financing and Investment Decisions: A Simultaneous Equations Framework. *Financial Review*, 42, 191-209.
- [13] Lien, D. and Yang, L. 2006, Spot-Futures Spread, Time-varying Correlation, and Hedging With Currency Futures. *Journal of Futures Market*, 26, 1019-1038.
- [14] Markar, S. D. and Huffman, S. P. 1997, Foreign Currency Risk Management Practices in U.S. Multinationals. *Journal of Applied Business Research*, 13, 73-86.
- [15] Myers, S. C. 1977, Determinants of Corporate Borrowing. *Journal of Financial Economics*, 5, 147-175.
- [16] Mian, S. L. 1996, Evidence on Corporate Hedging Policy. *Journal of Financial and Quantitative Analysis*, 31, 419-439.
- [17] Nance, D. R., Smith, C. W. Jr. and Smithson, C. W. 1993, On the Determinants of Corporate Hedging. *Journal of Finance*, 48, 267-284.
- [18] Stanley, B. B. and Timothy, J. G. 1986, The Use of Interest Rate Futures and Options by Corporate Financial Managers. *Financial Management Association International*, 15, 73-78.
- [18] Supanvanij, J. and Strauss, J. K. 2006, The Effects of Management Compensation on Firm Hedging: Does SFAS 133 Matter? *Journal of Multinational Financial Management*, 16, 475-493.
- [20] Tufano, P. 1996, Who Manages Risk? An Empirical Examination of Risk Management Practices in the Gold Mining Industry. *Journal of Finance*, 51, 1097-1137.
- [21] Venkatachalam, M. 1996, Value-relevance of Banks' Derivatives Disclosures. *Journal of Accounting and Economics*, 22, 327-355.
- [22] Zald, M. N. 1969, The power and functions of boards of directors: A theoretical synthesis. *American Journal of Sociology*, 75, 97-111.

# The Study of A Backpackers Traveling Risk Decision Making Analytic Model

Pin-Ju Juan, Peng-Yu Juan

Department of International Tourism Management  
Tamkang University<sup>1</sup>, Department of Marketing & Logistics Management  
Chung Chou University of Science and Technology<sup>2</sup>  
[pi@mail.tku.edu.tw](mailto:pi@mail.tku.edu.tw) [yuyu@dragon.ccut.edu.tw](mailto:yuyu@dragon.ccut.edu.tw)

## Abstract

*The study of risk perception is inadequate if it does not consider the motives for the visit to the particular destination, as well as the mechanism or "strategies" through which risk perceptions are minimized and mitigated. This study reports on research in progress on the subject of travelling risk evaluation and relates them to Asian destination selection process. This study aimed to determine the optimal destination for a backpacker to be constructed in Asia using analytic network process (ANP). Finally, a recommended solutions are presented and analyzed based on the strategic plan and can provide valuable insights for tourism administrators and academics in international tourism market.*

**Keywords:** Backpacker, Risk, Analytical Network Process (ANP), Asia.

## 1. Introduction

This study adopts the Analytic Network Process (ANP) for solving a destination selection problem based on the following motivations (Saaty, 2000), characteristics of the ANP: (1) by allowing for interdependence among, the ANP goes beyond the AHP by including independent and hence considers the AHP as a special case; (2) the ANP deals with interdependence within a set of elements (inner dependence), and among different sets of elements (outer dependence); (3) the ANP is a non-linear structure that deals with sources, cycles and sinks that have a hierarchy of linear form with goals on the top level and alternatives on the bottom level (Saaty, 2000). Thus, the ANP approach is utilized to solve the evaluation and selection problem. Additionally, this study uses a numerical example to illustrate the steps in the proposed method. Base on results, we conclude that the weights of have a central role when selecting a travel destination. The ANP is the generic form of the AHP, and allows for complex

interdependent relationships among elements (Saaty, 2001). The proposed develop Analytic Network Process (ANP) evaluation structure approach generates more informative and accurate results than the conventional ANP for destination analysis. The ANP-based decision-making approach provides expert decision-makers with a valuable reference for selecting the Asia destination for international backpackers.

Notably, the government of Taiwan has focused on developing international tourism through a plan to double the number of arriving tourists. In fact, the competitiveness of tourism businesses depends on environmental conditions because the environment is the main basis of tourism activity (Swann, 2010; Ribes *et al.*, 2011). In addition, risk perceptions are strongly associated with tourist's destination choice (Fuchs and Reichel, 2004, 2006; Pizam and Mansfeld, 1996; Sonmez and Graefe, 1998b). Risk-related perceptions and behavior appear to be relevant to the attempt of this study to compare between backpackers who traveled to different destinations (Reichel *et al.*, 2009).

Bowerman (2011) survey of backpacker travel across Asia Pacific, followed by the key factors impacting its current and future development. Destination summaries are divided into three sections: established destinations, including India, Indonesia, Malaysia, Nepal, the Philippines and Thailand; the emerging nations of Cambodia, China, Laos, Myanmar (Burma), Sri Lanka and Vietnam; and places traditionally less visited by backpackers, such as Japan, South Korea and Taiwan. Analysis is also provided of the established backpacker gateway entry/exit hubs of Hong Kong and Singapore, and alternative entrances such as Bangkok in Thailand and Kuala Lumpur in Malaysia. Finally, commentary is provided on established and emerging backpacker trails, plus insight into the future of the Asia-Pacific backpacking consumer and the budget travel economy that sustains them.

Throughout South East Asia, young Western tourists with large backpacks can commonly be observed clambering out of cycle rickshaws or local buses and peering reverently as they search for cheap accommodation or details about ancient temples. However, despite their numbers in the region and undoubted economic, social, cultural, and environmental impacts, this international tourism sector (broadly defined as people who travel with backpacks) has yet to receive serious academic study (Hampton and Hamzah, 2010). In addition, government planners in most South East Asian countries, while targeting foreign tourism as the engine of rapid economic and social development strategies, appear to focus their attention solely upon international mass tourism. In contrast, the backpacker sector is at best tacitly ignored, or at worst actively discouraged in official tourism planning (Richter 1993:185; Hampton and Hamzah, 2010).

The study of tourist destination risk perception has gained considerable visibility over the past decade. Clearly, the fragile geopolitical situation in numerous parts of the world, the outbreak of potentially global epidemics, as well as the increase in political violence generate interest in this issue beyond the academic sphere. For some destinations, the issue of security and safety has become a major concern for policy makers and legislators as well as for marketing and businesspeople (Pizam and Mansfeld, 1996). These concerns are magnified in the case of destinations that are under perpetual threat and affected by geo-political unrest and acts of terror. For such volatile destinations, understanding tourists' risk perception might assist in the formulation of marketing strategies that will consider the various dimensions of risk perceptions and that will mitigate some of the psychological barriers to travel.

Moreover, the study of risk perception is inadequate if it does not consider the motives for the visit to the particular destination, as well as the mechanism or "strategies" through which risk perceptions are minimized and mitigated. The most frequently studied situation is in which a consumer decides to purchase a ticket or a vacation package to a destination with a particular mix of risks. It is much more challenging, however, to examine the destination risk perception and risk reduction strategies and particular motives of tourists who choose to return to a risky destination. The study's main research question focuses on how destination risk perception, tourist risk reduction strategies and particular motivation for the visit, vary between first-

time visitors and repeat visitors. This comparison between first-time and repeat visitors may add a particularly significant dimension when conducted in the context of "chronically" volatile destinations. Thus, the purpose of this exploratory study is to compare first-time visitors and repeat visitors in a highly volatile environment in terms of destination risk perception, risk reduction strategies and motives for visiting that particular destination. Specifically, first-time visitors to Israel will be compared to repeat visitors in terms of their destination risk perception, risk reduction strategies as well as motives for their visit. Utilizing a sample of 760 visitors to Israel, the expected differences between first-time and repeat visitors will be identified mainly by applying discriminant analysis. Identification of a particular profile of each sub-segment will increase our understanding of tourist behavior as well as enable conclusions and recommendations from destination marketing and management perspectives.

To explore the implementation of the backpacker destination assessment model, this study is used herein to elucidate the relationship between the identification and assessment of destination selection to specific development objectives. The model criteria are obtained from a detailed literature review and by the use of the modified Delphi method. Following expert interviews, a hierarchy of evaluation criteria was established, and ANP was used to calculate the weight and relative importance of each criterion. The proposed evaluation criteria are useful for the development of a method of backpacker risk assessment by tourism administrators and academics for use in travelling risk reduction of destination optimization.

## **2. Method**

This section reviews related literature, including the travelling risk and the ANP method. As well as a literature review and expert interviews, the travelling risk and ANP theory are also used to design a new method for assessing destination selection. Its effectiveness is tested. The theoretical approaches used herein are described below.

### ***Travelling Risk***

Risk is a challenging concept to define, understand and ultimately to manage. The range of risks considered should not be limited by those that are insurable or fortuitous. Tsaur *et al.* (1997) used an Analytic Hierarchy Process method in their study to

determine the weight structure of "objectives" and "attributes" risk evaluation criteria (i.e. the relative importance of each perceived risk dimension or specific sub-items). their study was intended to cover two main types of risk: physical risk, referring to the possibility that an individual's health is at risk, injury and sickness because of conditions such as law and order, weather and hygiene problems, and equipment risk, referring to the dangers arising from the malfunctioning of equipment, such as unsafe transportation. The backpacker tourism not only shields backpackers from the local people, food and customs, but also dilutes the novelty and risk associated with the unfamiliar (Lepp and Gibson, 2003). Based on the above, this study argued that travelling risks are as follows.

1. Transportation: model of transportation, the transportation risk factors, including take public transportation, take private transportation, transportation in a car and transportation on a flight.

2. Law and order: such as local people attitude towards the government's rules. terrorism and political instability are not unrelated (Sonmez, 1998; Sonmez and Graefe, 1998a).

3. Food and hygiene: Food risk judgments were found to vary over risk sources and to vary with national backgrounds sources and to vary with national backgrounds (Larsen, 2007).

4. Accommodation: Most backpackers choose places to stay based on economic considerations, usually electing the cheapest places available to save money and allow for a much longer sojourn at a particular place (Hampton, 1998; Muzaini, 2006). Therefore, accommodation environment will be very important, risk factors including injury caused by fire, electrocution, cleanliness of hostels, location of hostels and sexual harassment.

5. Weather and other environmental: most backpackers were complains weather and other environmental, including changes in weather conditions, man-made disasters, waste cleanup and water hazards (Fuchs and Reichel, 2006).

6. Sightseeing and other recreational facilities: risk factors including public recreational facilities, private tourist attractions, going shopping and night out on the town.

7. Public Utility: risk factors including healthcare facility, ability of medical staff, emergency response, tel-communication system, roads and bridges and information centers.

While not the first model to do so. Additionally, This Model helps to identify travelling risk linkages

among the seven determinants, and can accurately forecast future trends.

### *ANP*

The ANP, which was first developed by Saaty (1980) helps establish decision models for a process containing both qualitative and quantitative components. Qualitatively, ANP decomposes a decision problem from the top overall goal to a set of manageable clusters and sub-clusters, down to the bottom level, which typically contains scenarios or alternatives. The clusters and sub-clusters can be forces, attributes, criteria, activities, or objectives. Quantitatively, ANP uses pair-wise comparisons to assign weights to elements at the cluster and sub-cluster levels, and finally calculates "global" weights for assessments at the bottom level. Each pair-wise comparison measures the relative importance or strength of elements within a cluster level using a ratio scale. One of the primary functions of the AHP is to calculate a consistency ratio to determine whether the matrices are appropriate for analysis (Saaty, 1980). However, AHP models assume that uni-directional relationships exist between elements at different decision levels in a hierarchy and uncorrelated elements within each cluster, as well as between clusters. Models that specify interdependent relationships in the AHP are inappropriate. The ANP is then developed to fill this overcome this shortcoming.

The ANP is also known as the systems-with-feedback approach (Meade & Sarkis, 1998). By incorporating interdependencies (i.e., addition of feedback loops in the model), a super-matrix is created. The super-matrix adjusts the relative weights of individual matrices to form a new overall matrix with eigenvectors of the adjusted relative weights (Meade & Sarkis, 1998). Notably, ANP utilizes a network without needing to specify levels as in a hierarchy. The primary reason for choosing the ANP as the methodology for selecting destination is due to its suitability in offering solutions in a international backpackers complex multi-criteria decision environment.

The elements in a node can influence some or all elements in any other node. A network can have source nodes, intermediate nodes and sink nodes. Relationships in a network are represented by arcs, and the directions of arcs indicate dependence (Saaty, 2001). Interdependency between two nodes, called outer dependence, is represented by a two-way arrow, and inner dependencies among elements in a node are

represented by a looped arc (Sarkis, 2003). The procedure in the ANP has four principal steps (Meade & Sarkis, 1999; Saaty, 2001).

[Figure 2. Structural difference between a hierarchy and network - (a) a hierarchy; (b) a network.] is about here.

Step 1: Model construction and problem structuring

The problem must be stated clearly and decomposed into a rational system, such as a network. The structure can be generated based on decision-maker opinions generated through, say, brainstorming or other methods. Figure 2 (b) presents an example of a network format.

Step 2: Pair-wise comparison matrices and priority vectors

In the ANP, like the AHP, decision elements for each component are compared pair-wise with respect to their importance in terms of their control criterion, and the components are also compared pair-wise with respect to their contribution to a goal. Decision-makers are asked to respond to a series of pair-wise comparisons in which two elements or two components are compared based on how they contribute to their particular upper level criterion (Meade & Sarkis, 1999). Additionally, when interdependencies exist among elements in a component, pair-wise comparisons must also be performed, and an eigenvector can be derived for each element that indicates the affects of other elements on that element. The relative importance values are determined on a scale of 1-9, where a score of 1 represents equal importance between two elements and a score of 9 indicates extreme importance of one element (row component in the matrix) compared to another element (column component in the matrix) (Meade & Sarkis, 1999). A reciprocal value is assigned to the inverse comparison; that is,  $a_{ij} = 1 / a_{ji}$ ; where  $(a_{ij})$  is the importance of the  $i$ th ( $j$ th) element compared to the  $j$ th ( $i$ th) element. Like the AHP, pair-wise comparisons in the ANP are in the framework of a matrix, and a local priority vector can be derived as an estimate of relative importance associated with elements (or components) being compared by solving the following formula:

$$A \cdot w = \lambda_{\max} \cdot w, \quad (1)$$

where  $A$  is the matrix of a pair-wise comparison,  $w$  is the eigenvector, and  $\lambda_{\max}$  is the largest eigenvalue of  $A$ . Saaty (1980) developed several

algorithms for approximating  $w$ : In this study, the following three-step procedure is utilized to synthesize priorities (Meade & Presley, 2002).

- Sum the values in each column in the pair-wise comparison matrix.
- Divide each element in a column by the sum of its respective column. The resulting matrix is then called the normalized pair-wise comparison matrix.
- Sum the elements in each row of the normalized pair-wise comparison matrix, and divide the sum by the  $n$  elements in the row. These final values provide an estimate of relative priorities for compared elements with respect to the upper level criterion. Priority vectors must be derived for all comparison matrices.

Step 3: Supermatrix formation

The supermatrix concept is similar to the Markov chain process (Saaty, 2001). To acquire global priorities in a system with interdependent influences, local priority vectors are entered in the appropriate columns of a matrix, which is known as a supermatrix. Consequently, a super-matrix is actually a partitioned matrix, in which each matrix segment represents a relationship between two nodes (components or clusters) in a system (Meade & Sarkis, 1999). Let the components of a decision system be  $C_k$ ,  $k = 1, 2, \dots, N$ , which has  $n_k$  elements denoted as  $e_{k1}, e_{k2}, \dots, e_{kn_k}$ . The local priority vectors obtained in Step 2 are grouped and allocated to the appropriate positions in a super-matrix according to the flow of influence from one component to another, or from a component to itself as in a loop. A standard form of a super-matrix is as in Eq. (2) (Saaty, 2001).

$$\begin{matrix} & C_1 & \dots & C_k & \dots & C_N \\ e_{11} & e_{11} & \dots & e_{1n_1} & \dots & e_{1n_1} \\ \vdots & \vdots & & \vdots & & \vdots \\ e_{1n_1} & \vdots & & \vdots & & \vdots \\ \vdots & \vdots & & \vdots & & \vdots \\ e_{k1} & \vdots & & \vdots & & \vdots \\ \vdots & \vdots & & \vdots & & \vdots \\ e_{N1} & \vdots & & \vdots & & \vdots \\ \vdots & \vdots & & \vdots & & \vdots \\ e_{Nn_N} & \vdots & & \vdots & & \vdots \end{matrix} \begin{bmatrix} W_{11} & \dots & W_{1k} & \dots & W_{1N} \\ \vdots & & \vdots & & \vdots \\ \vdots & & \vdots & & \vdots \\ \vdots & & \vdots & & \vdots \\ \vdots & & \vdots & & \vdots \\ \vdots & & \vdots & & \vdots \\ \vdots & & \vdots & & \vdots \\ \vdots & & \vdots & & \vdots \\ \vdots & & \vdots & & \vdots \\ \vdots & & \vdots & & \vdots \end{bmatrix} \quad (2)$$

As an example, a supermatrix representation in a hierarchy with three levels (Fig. 2(a)) is as follows (Saaty, 2001):

$$\begin{matrix} C_1 & C_2 & C_3 \\ e_{11} & e_{12} & e_{13} \\ \vdots & \vdots & \vdots \\ e_{N1} & e_{N2} & e_{N3} \end{matrix} \begin{bmatrix} 0 & 0 & 0 \\ W_{21} & 0 & 0 \\ 0 & W_{32} & I \end{bmatrix}, \dots \quad (3)$$

where  $W_{21}$  is a vector representing the impact of the goal on the criteria,  $W_{32}$  is a matrix representing the impact of criteria on each alternatives,  $I$  is an



identity matrix, and zeros correspond to elements that have no impact.

For this example, when criteria are interrelated the hierarchy is replaced by a network Fig. 2(b). The (2, 2) entry of  $W_n$  given by  $W_{22}$  indicates interdependency, and the supermatrix would be (Saaty, 2001)

$$W_n = \begin{bmatrix} 0 & 0 & 0 \\ W_{21} & W_{22} & 0 \\ 0 & W_{32} & I \end{bmatrix}, \quad (4)$$

Notably, any zero in the supermatrix can be replaced by a matrix when an interrelationship exists between elements in a component or between two components. As an interdependence typically exists among clusters in a network, the sum of columns in a supermatrix usually is typically greater than  $> 1$ . The supermatrix must first be transformed to make it stochastic, in other words, each column in a matrix sums to unity. In other words, the row components with nonzero entries for the blocks in a given column block are compared according to their impact on the component of that column block (Saaty, 2001). An eigenvector can be obtained for a pair-wise comparison matrix of the row components with respect to the column component. This process yields an eigenvector for each column block. The first entry of the respective eigenvector for each column block is multiplied by all elements in the first block of that column, the second entry is multiplied by all elements in the second block of that column – this process continues. In this manner, the block in each column of the supermatrix is weighted the result is known as a weighted supermatrix, which is stochastic.

Raising a matrix to powers generates the long-term relative influences each elements has on each other element. To attain a convergence on importance weights, the weighted supermatrix is raised to the power of  $2k+1$ , where  $k$  is an arbitrarily large number. This new matrix is called a limit supermatrix (Saaty, 2001). A limit supermatrix has the same form as a weighted supermatrix, however, all the columns in the limit supermatrix are the same. By normalizing each block of this supermatrix, the final priorities of all elements in the matrix can be derived.

#### Step 4: Selection of best alternatives

When the supermatrix formed in Step 3 covers the entire network, the priority weights of alternatives are found in the column of alternatives in the normalized supermatrix. Conversely, when a supermatrix only

has interrelated components, additional calculations must be performed to acquire the final priorities of alternatives. The alternative with the largest overall priority should be selected. In this study, the ANP is applied, and a supermatrix covering the entire network bracket in Fig. 3.

[Figure 3. Network form for this papre.] is about here.

As the proposed ANP is a multi-attribute, decision-making approach based on reasoning, knowledge and experience of experts the ANP is a valuable aid for decision-making involving both tangible and intangible attributes associated with the model under study. The ANP relies on the process of eliciting managerial inputs, thereby allowing for structured communication among decision-makers. Thus, the ANP can act as a qualitative tool for strategic decision-making problems. Eddie, Cheng and Ling (2005) applied the ANP to select the best site for a shopping mall. Wu and Lee (2007) developed an effective method based on the ANP to help companies that must assess and select knowledge management strategies. Lin, Chiu, and Tsai (2007) utilized the ANP approach to construct a dispatching model based on the characteristics of all on-site production facilities and examine the relationships among various performance indicators and the correlations between performance indicators and dispatching rules. These studies demonstrate the appropriateness of using the ANP for strategic facility type. Although the ANP produces a comprehensive analytic framework for solving societal, governmental, and corporate decision problems few studies have applied the ANP for selecting the destination for international backpackers. This study uses the ANP for selecting the best destination for international backpackers in Asia.

#### *Illustrative example*

Based on a review of destination selection evaluations for international backpackers, this study constructed indicators for destination selection. The modified Delphi approach is then adopted to summarize expert opinions and construct an evaluation model for destination selection for international backpackers. Based on factors affecting destination selection of international backpackers, i.e., transportation, law and order, food and hygiene, accommodation, weather and other environment,

sightseeing and other recreation facilities, applied the ANP is utilized to identify the problems and combine these six factors in establishing a hierarchy and network structure for performance evaluation. Finally, destination for international backpacker in Asia are the research objects in this study. According to expert opinions, six Asia areas - Northern Asia, Southern Asia, Southeastern Asia, Eastern Asia, Western Asia and Central Asia - are considered.

The expert ANP evaluation model attempts to select the destination for international backpacker in Asia based on travelling risk. This process has the following steps.

Step 1: Select and define evaluative criteria and establish an ANP model.

Here, the modified Delphi approach is applied for selecting and defining evaluation criteria and sub-criteria. Finally, according to the input from 40 experts, such as academics and international backpackers, validate the six evaluation criteria and 25 evaluation sub-criteria.

The modified Delphi method is utilized to obtain criteria. Next, a general consensus among experts was reached and generated a hierarchical structure that considers the dependence of factors. The final goal of evaluating ideal destination was achieved Fig. 4 followed by six evaluation criteria, 25 evaluation sub-criteria and finally alternatives destination for international backpackers - Northern Asia, Southern Asia, Southeastern Asia, Eastern Asia, Western Asia and Central Asia - were identified.

**[Figure 4. Hierarchical structure to select and evaluate the optimal destination for international backpacks with respect to travelling risk.] is about here.**

● Transportation ( $C_1$ )

The model of transportation, the transportation risk factors, including take public transportation, take private transportation, transportation in a car and transportation on a flight.

● Law and order ( $C_2$ )

Such as local people attitude towards the government's rules. terrorism and political instability are not unrelated (Sonmez, 1998; Sonmez and Graefe, 1998a).

● Food and hygiene ( $C_3$ )

Food risk judgments were found to vary over risk sources and to vary with national backgrounds sources and to vary with national backgrounds (Larsen, 2007).

● Accommodation ( $C_4$ )

Most backpackers choose places to stay based on economic considerations, usually electing the cheapest places available to save money and allow for a much longer sojourn at a particular place (Hampton, 1998; Muzaini, 2006). Therefore, accommodation environment will be very importation, risk factors including injury caused by fire, electrocution, cleanliness of hostels, location of hostels and sexual harassment.

● Weather and other environmental ( $C_5$ )

Most backpackers were complains weather and other environmental, including changes in weather conditions, man-made disasters, waste cleanup and water hazards (Fuchs and Reichel, 2006).

● Sightseeing and other recreational facilities ( $C_6$ )

Risk factors including public recreational facilities, private tourist attractions, going shopping and night out on the town.

Step 2: Establish a pair-wise comparison matrix and determine eigenvectors.

The weights of level 2 and level 3 are then determined for a sample group of 25 factors matching the above characteristics with each respondent who makes a pair-wise comparison of the decision elements and assigning relative scores. The relative scores provided by 40 experts are summed using the geometric mean method. Table 1 presents the aggregate pair-wise comparison matrix for the criteria. The eigenvectors for levels 2-3 (Table 2) include the respective weights of the six evaluative criteria ( $W_{21}$ ) and the respective weights of the 22 evaluative sub-criteria ( $W_{32}$ ). We assume no interdependence exists among criteria and sub-criteria, thus, criteria and sub-criteria should be emphasize when determining their respective upper-level criterion. The priorities for the criteria,  $W_{34}$ ; Table 3 presents the weights of the 25 sub-criteria in level 4.

**[Table 1. Aggregate pair-wise comparison matrix for criteria of level 2.] is about here.**

**[Table 2. Eigenvectors (weights) for level 2 and level 3.] is about here.**

**[Table 3. Eigenvectors (weights) for level 4.] is about here.**

Step 3: Establish pair-wise comparison matrices of interdependencies.

Travelling risks determines the inner interdependence among criteria (Figure 1). The resulting eigenvectors obtained from pair-wise comparisons form matrix,  $W_{22}$  (Table 4). Notably, zeros are assigned to eigenvector weights for criteria that are independent. Based on expert interviews the interdependence among sub-criteria is analyzed next. Figure 5 presents an analytic network process hierarchical structure with computer-based system. The relative importance weights of the interdependence among detailed criteria are represented by  $W_{33}$  (Table 5).

**[Figure 5. Analytic network process hierarchical structure with computer-based system.] is about here.**

**[Table 4. Inner Dependence Matrix of Criteria,  $W_{22}$ .] is about here.**

**[Table 5. Inner Dependence Matrix of Sub-criteria,  $W_{33}$ .] is about here.**

Step 4: Establish a supermatrix and limit matrix.

A supermatrix allows for identification of the effects of interdependence between system elements. A supermatrix is a partitioned matrix, in which each sub-matrix is composed of vectors obtained from pair-wise comparisons. As discussed in the Appendix and dotted parentheses in Fig. 3, the supermatrix in this study covers all network elements. Figure 6 shows the generalized form of the supermatrix. The supermatrix, inserted with respective vectors and matrices obtained prior to before in Table 6. Because the supermatrix includes interactions between clusters, (e.g. an inter dependence exists among criteria and among sub-criteria), not all columns sums to 1. A weighted supermatrix is transformed first to be stochastic (Table 7). After entering normalized values into the supermatrix and completing the column stochastic, the supermatrix is then raised to a sufficiently large power until convergence occurs. The current super-matrix reached convergence and attained a unique eigenvector. Table 8 presents the final limit matrix. This limit matrix is column stochastic and represents the final eigenvector. Synthesis, with respect to selection of destinations, obtained the following results, Central Asia (0.390), Southern Asia (0.282), Western Asia (0.176), Southeastern Asia (0.127), Eastern Asia (0.019),

Northern Asia (0.006). Thus, the optimal travelling risk destination is Central Asia.

**[Figure 6. Generalized supermatrix.] is about here.**

**[Table 6. The Supermatrix.] is about here.**

**[Table 7. The Weighted Supermatrix.] is about here.**

**[Table 8. The Limit Supermatrix.] is about here.**

Identical results are obtained for Central Asia was the most risk destination in Asia selected here. The six risk destination of areas in Asia are ranked as Central Asia (0.390) > Southern Asia (0.282) > Western Asia (0.176) > Southeastern Asia (0.127) > Eastern Asia (0.019) > Northern Asia (0.006).

### *Conclusions*

This study develops an evaluation criterion for optimizing the selection of reduction risk destinations in Asia. The Central Asia would be the most risk destination area in Asia. However, Northern Asia would be the most safety destination area in Asia. The proposed evaluation criterion provides policymakers and academics with a basis for making recommendations regarding future backpacker travelling development. The objective factor is implemented in various alternative scenarios based on the best global indicators. Additionally, subjective factor is measured using ANP. The selection of a reduction risk destination is a complex problem. This study uses ANP to reduce errors in decision making. Tourism administrators or decision-makers should prioritize backpacker travelling for cooperation or investment. Finally, this study recommends that tourism administrators or decision makers use the proposed model to evaluate the business dynamics of reduction risk backpacker market.

Table 2. Goal aggregate pair-wise comparison matrix and eigenvectors for level 2

Table 2. Goal aggregate pair-wise comparison matrix and eigenvectors for level 2

Goal	Transportation	Law and Order	Food and Hygiene	Accommodation	Weather and other environmental	Sightseeing and other recreational facilities	Eigenvectors (weights)
Transportation	1.000	0.963	1.636	2.456	1.977	2.849	0.255
Law and Order	1.039	1.000	1.699	2.551	2.053	2.959	0.265
Food and Hygiene	0.611	0.589	1.000	1.501	1.208	1.742	0.156
Accommodation	0.407	0.392	0.666	1.000	0.805	1.160	0.104
Weather and other environmental	0.506	0.487	0.828	1.242	1.000	1.441	0.129
Sightseeing and other recreational facilities	0.351	0.338	0.574	0.862	0.694	1.000	0.090

Note:  $\lambda_{max} = 8.2148$ ; CI=0.0000; CR=0.0000

Table 4: Inner Dependence Matrix of Criteria,  $W_{22}$

$W_{22}$	$C_1$	$C_2$	$C_3$	$C_4$	$C_5$	$C_6$
$C_1$	0	0	0	0	0.232	0.296
$C_2$	0.548	0	0	0	0.296	0.316
$C_3$	0.280	0	0	0	0.274	0.226
$C_4$	0.172	0	0	0	0.199	0.163
$C_5$	0	0	0	0	0	0
$C_6$	0	0	0	0	0	0

## References

- [1] Ananda, J. and Herath, G. (2002) Assessment of wilderness quality using the Analytic Hierarchy Process. *Tourism Economics*, 8 (2), 189-206.
- [2] Bowerman, G. (2011) Backpacker trails in Asia Pacific. *Travel & Tourism Analyst*, 20, 2-37.
- [3] Chen, C.F. (2006) Applying the analytical hierarchy process approach to convention site selection. *Journal of Tourism Research* 45(2), 167-174.
- [4] yer, R.F. and Forman, E.H. (1992) Group decision support with the Analytic Hierarchy Process. *Decision Support Systems* 8(2), 99-124.
- [5] Eddie, W.L., Cheng, H.L. and Ling, Y. (2005). The analytic network process (ANP) approach to location selection: a shopping mall illustration. *Construction Innovation*, 5(2), 83-97.
- [6] Fuchs, G. and Reichel, A. (2004) Cultural differences in tourist destination risk perception: An exploratory study. *Tourism* 52(1), 21-37.
- [7] Fuchs, G. and Reichel, A. (2006) Tourist destination risk perception: The case of Israel. *Journal of Hospitality and Leisure Marketing* 14(2), 81-106.
- [8] Hampton, M. P. and Hamzah, A. (2010) *The Changing Geographies of Backpacker Tourism in South-East Asia*. Kent Business School Working Paper Series.
- [9] Hsu, T. K., Tsai, Y. F. and Wu, H. H. (2009) The preference analysis for tourist choice of destination: A case study of Taiwan. *Tourism Management* 30(2), 288-297.
- [10] Ivanov, S. and Webster, C. (2007) Measuring the impact of tourism on economic growth. *Tourism Economics* 13(3), 379-88.
- [11] Juan, P.J. and Lin, S.Y. (2011) Resort hotel location. *Tourism Economics* 17(4), 925-931.
- [12] Kajanus, M., Kangas, J. and Kurttila, M. (2004) The use of value focused thinking and the A'WOT hybrid method in tourism management. *Tourism Management* 25(4), 499-506.
- [13] Lepp, A. and Gibson, H. (2003) Tourism roles, perceived risk and international tourism. *Annals of Tourism Research* 30(3), 606-624.
- [14] Lin, Y.H., Chiu, C. C. & Tsai, C. H. (2007). The study of applying ANP model to assess dispatching rules for wafer fabrication. *Expert Systems with Applications*, In Press, Corrected Proof, Available online 4 March, 1-16.
- [15] Meade, L.M and Sarkis, J. (1998). Strategic analysis of logistics and supply chain management systems using the analytic network process. *Transportation Research Part E: Logistics and Transportation Review*, 34(3), 201-215.
- [16] Meade, L.M. and Sarkis, J. (1999). Analyzing organizational project alternatives for agile manufacturing processes- an analytical network approach. *International Journal of Production Research*, 37(2), 241-261.
- [17] Moutinho, L. and Curry, B. (1994) Modeling site location decisions in tourism. *Tourism Management* 3(2), 35-56.
- [18] Murry, J.W. and Hammons, J.O. (1995). Delphi: a versatile methodology for conducting qualitative research. *Review of Higher Education*, 18(4), 423- 436.
- [19] Muzaini, H. (2006) Backpacking Southeast Asia: Strategies of "Looking Local". *Annals of Tourism Research* 33(1), 144-161.
- [20] Pizam, A. and Mansfeld, Y. (1996) *Tourism, Crime and International Security Issues*. John Wiley & Sons, New York.
- [21] Ramanathan, R., Subramanian, G. and Chaudhuri, D. (2010) Quantitative assessment of stakeholder perceptions for tourism development. *Tourism Economics* 16(1), 99-116.
- [22] Reichel, A., Fuchs, G. and Uriely, N. (2009) Israeli backpacker: The role of destination choice. *Annals of Tourism Research* 36(2), 222-246.
- [23] Ribes, J.F.P., Rodriguez, A.R. and Jimenez, M.S. (2011) Determinants of the competitive advantage of residential tourism destinations in Spain. *Tourism Economics* 17(2), 373-403.

- [24] Saaty, T.L. (1980) *The Analytic Hierarchy Process*. New York: McGraw Hill.
- [25] Saaty, T.L. (1980). The analytic hierarchy process. New York, NY: McGraw-Hill.
- [26] Saaty, T.L. (1990) How to mark a decision: The analytic hierarchy process. *European Journal of Operational Research* 48(1), 9-26.
- [27] Saaty, T.L. (1994). Highlights and critical points in the theory and application of the Analytic Hierarchy Process. *European Journal of Operational Research*, 74(3), 426-447.
- [28] Saaty, T.L. (2000). Fundamentals of decision making and priority theory with the analytic hierarchy process AHP series. Vol. VI (pp. 1-478), Pittsburgh: RWS Publications.
- [29] Saaty, T.L. (2001), Decision making with dependence and feedback: the analytic network process. Pittsburgh: RWS Publications.
- [30] Sarkis, J. (2003). A strategic decision framework for green supply chain management. *Journal of Cleaner Production*, 11(4), 397-409.
- [31] Sonmez, S. F. (1998). Tourism, terrorism, and political instability. *Annals of Tourism Research* 25(2), 416-456.
- [32] Sonmez, S.F. and Graefe, A. R. (1998a) Influence of terrorism risk on foreign tourism decisions. *Annals of Tourism Research* 25(1), 112-144.
- [33] Sonmez, S.F. and Graefe, A. R. (1998b) Determining future travel behavior from past travel experience and perceptions of risk and safety. *Journal of Travel Research*, 37(4), 171-177.
- [34] Tzeng, G.H., Teng, M.H., Chen, J.J. and Opricovic, S. (2002). Multicriteria selection for a restaurant location in Taipei. *International Journal of Hospitality Management* 21(2), 171-187.
- [35] Vaidya, O.S. and Kumar, S. (2006). Analytic hierarchy process: An overview of applications. *European Journal of Operational Research* 169(1), 1-29.



# Towards researching the conflict and dispute resolution practices of vulnerable communities: the case of the San ('Bushmen') of Southern Africa

Dr Andreas Velthuizen

Institute for Dispute Resolution in Africa, College of Law, University of South Africa  
[velthag1@unisa.ac.za](mailto:velthag1@unisa.ac.za)

## Abstract

*The paper is presented against the background of the need for suitable research methodology to learn from conflicts and dispute resolution practices of vulnerable communities, in this case the San ('Bushmen') of Southern Africa. The question is asked what research methodology should be used to access the knowledge of 'first people communities' such as the San, who experiences all types of conflict and disputes over a long time in different circumstances. In a quest to answer this question, the presenter aims to establish a trans-disciplinary research methodology that can be applied specifically for research on the conflict and dispute resolution practices of the San. In order to achieve this aim, the presenter discusses the triangulation of appreciative inquiry, content analysis, and conflict mapping as methods of analysis to determine the patterns of how the conflict evolved over time and space as a knowledge foundation to resolve current disputes.*

## Introduction

Literature about the San is not new. Early descriptions tend to be negative describing the San as a primitive people [29]. Later writings such as that of van der Post [30] viewed the San with a romantic eye, a trend that continues today with contemporary writers producing interesting non-academic work after spending time with the San, called "Bushmen" by some.

The term San will be used for purpose of this presentation, because that is what the community of Platfontein prefers to be called, recognizing that other San communities may prefer to be called something

else. The term "Bushmen" is avoided because the author agrees that it is derogatory and not an accurate description of the modern 'First Peoples' of Africa. Consensuses among authors are that the San were people that lived all over Southern Africa as gatherer hunters. The arrival of other nations forced them into areas with extreme climatic conditions where other people did not want to live. Later their existence was threatened by cattle herders and war. Eventually they had no other choice than to westernise in search for work. First people's communities such as the San suffered severe consequences of migration patterns contributed by colonialism in Africa and during the Cold War when they were used by all sides in internal and internationalised conflicts [31].

The question is asked what research methodology should be used to access the knowledge of 'first people communities' such as the San, who experiences all types of conflict and disputes over a long time in different circumstances. In a quest to answer this question, the presenter aims to establish a trans-disciplinary research methodology that can be applied specifically for research on the conflict and dispute resolution practices of the San.

A trans-disciplinary methodology implies an approach that will allow a unity of knowledge to understand the world of the San [32]. The knowledge foundation of the methodology is a literature study of research methodology that applies to trans-disciplinary research in an African context, involving sociology, Afrikology, glocality and modern anthropology.

From sociology, content analysis tools and the methods of semi-structured interviews, focus group discussions and interpretative workshops, will be borrowed. The approach to the research will accept

---

## References

- [<sup>29</sup>]Casalis, E. *The Basutos* (1997 reprint). Morija Museum & Archives, Morija, 1861.  
[<sup>30</sup>]Van der Post, L. *The Heart of the Hunter*. London, Hogarth Press, 1961.

---

[<sup>31</sup>]Robbins, D., *A San Journey: The Story of the !Xun and Khwe of Platfontein*, Kimberley, Sol Plaatjie Educational Trust, 2012.

[<sup>32</sup>]Nicolescu, B. *Towards Transdisciplinary Education and Learning*, Philadelphia. Metanexus Institute, 2005.



Afrikology that refers to an approach to research on a level of reality that includes the normative and spiritual realm of African epistemology encompassing a consciousness of the universe, humanity and language. Afrikology also involves glocalology, a holistic consciousness aiming to bring about a new a just society through restorative learning and understanding founded on the recovery of the “divine word from the heart” and the recognition of the importance of dialogue between different traditions in a quest for the truth[33]. The study is also borrowing from modern anthropology, meaning not a study *of* some object, but a study *with* people immersed with them in joint activity, experience to educate our *perception* of the world to “open our eyes and minds” to other possibilities of being.[34]

The knowledge foundation of the study is therefore rather endogenous than indigenous, implying that the African way of knowing is the result of lived experiences found within a community affected by contact with other communities, assuming that knowledge of the San community is not static but develops continuously. Endogenous knowledge means viewing the world from the vantage point of local people, independent from dominant Eurocentric world-views. The participatory process builds convergences and sustained interaction between formal and informal institutions while empowering community beneficiaries through programmes and projects. [35]

Using the San community of Platfontein in the Northern Cape Province of South Africa as a case study, the author argues that research methodology should be a triangulation of appreciative inquiry, content analysis and conflict mapping, using narratives derived from the collective memory and oral culture of the San community. Methodology should determine not only the structural aspects of a conflict, but also recursive patterns of how conflict and disputes were managed in time and space.

### **An anatomy of vulnerability: the San community of Platfontein in the Northern Cape Province of South Africa**

#### **A history of vulnerability**

---

[<sup>33</sup>]Nabudere, D.W., *Afrikology and Trans-disciplinarity: A Restorative Epistemology*, Pretoria, Africa Institute of South Africa, 2012,

[<sup>34</sup>]Ingold, T., *Being alive: essays on movement, knowledge and description*, New York, Routledge, 2011.

[<sup>35</sup>]Houtondji, P.J, “Knowledge of Africa, knowledge of Africans”, *RCCS Annual Review no. 1*, September 2009, p.10.

“First People” communities such as the San are vulnerable in the sense that they suffered severe consequences of migration patterns contributed by colonialism in Africa and during the Cold War when they were used by all sides in internal and internationalised conflicts in Africa. Over the past three hundred years, the San communities in South Africa have experienced colonial violence, dispossession and dislocation and forced into the driest and most remote parts of South Africa.

The San of Platfontein is no different. Since the late 1960s the !Xun Fletchas were serving in the Portuguese military in Southern Angola as trackers. In 1974 Portugal relinquished its colonies and pulled out of Angola. In 1974 the first group of !Xun soldiers crossed the border into Namibia, followed by whole communities of Khwe. They all settled at a base called Alpha (later Omega) in the Western Caprivi. In 1982 a second San base was established at Mangetti Dune in Northern Namibia. From 1975, San soldiers were involved in military operations in Namibia and Angola as part of the former South African Defence Force. In March 1990, after the independence of Namibia, the San were resettled in the Northern Cape province of South Africa.[36]

In 1999 the! Xun and Khwe, became owners of the Platfontein farm near Kimberley after almost a decade of living in tents. In June 1999, they were officially awarded the title deeds to the farms Platfontein, Wildebeeskuil and Droogfontein by former President Nelson Mandela.[37]

Today, the major challenges facing the!Xun and Khwe are division and segregation. While being called Vasekela and Barakwena in Angola, the terms !Xun and Khwe labelled the groups at Platfontein as separate ethnical entities and called for two spatially segregated settlements at Platfontein [38]. This ongoing social distance and tension between the!Xun and Khwe, with the intensification of the struggle over access to jobs (including employment opportunities at the new farms) and housing, could escalate. However, there is hope that the youth will be able to overcome this divide.[39]. These divisions have been aggravated by delays in the

---

[<sup>36</sup>]Robbins,D., *op. cit.*

[<sup>37</sup>]Robins, S., Madzudzo, E., Brenzinger, M., “Regional assessment of the status of the San in Southern Africa”, *Report series no. 2 of 5*, Windhoek. Legal Assistance Centre, 2001, p.2.

[<sup>38</sup>]Robbins, *op.cit.*

[<sup>39</sup>]Robbins, *op.cit.*

provision of infrastructure and contributed to high levels of frustration and conflict [40].

### **Traditional dispute resolution practices of the San**

Literature concerning dispute resolution practices of the San is not so common. In his work "A History of Alternative Dispute Resolution" [41] Laurence Boulle states:

"In the Kalahari desert in Botswana and Namibia the Bushmen have lived traditional lives for many thousands of years. The lack of technological refinement belies sophistication in dispute resolution practices which have evolved without courts and a formal state system and are suited to the needs of a collective hunter-gatherer society."

The most important work on San dispute resolution is probably that of Ury [42] who presents an analysis of traditional dispute resolution methods among the "Bushman", arguing that their traditional methods constitute a complete and effective dispute resolution system, meaning a system with six basic functions that:

- Seek to prevent disputes from arising.
- Resolve disputes by healing emotional wounds.
- Reconcile divergent interests.
- Determine which rights and norms are at stake, and decide which norms have precedence.
- Test relative power and avert the use of power-based strategies.
- Contain unresolved disputes to prevent escalation into violence, steering it back into the system for further resolution.

Ury asserts that San children are taught to fear and avoid violence and disputes. Discussions are led by the Elders until all negative feelings are exhausted. "Trance dance", consensual decision-making, confronting the offender with witnesses, testing relative power by figuring out who needs whom the most, containing violence by keeping parties away from each other and hiding of weapons are conflict-avoidance practices. According to Ury "the secret of the Bushmen

for managing conflicts is the vigilant, active, and constructive involvement of the community." [43]

### **The research methodology**

#### **Appreciative Inquiry (AI)**

Considering the history and traditional dispute resolution practices of the San, research methodology into dispute resolution requires appreciative inquiry, using narratives derived from the collective memory and oral culture to determine not only the structural aspects of a conflict, but also patterns of how the conflict evolved over time and space.

In this specific case, appreciative enquiry (AI) strengthens the collective capacity move away from problem analysis to imagining a better future evoked through enquiry, linking inquiry and interventionist change. AI principles implies that human knowledge and destiny is interwoven and that the past present and future are sources of learning and inspiration and interpretation, as well imagining a discourse about the future. [44] AI deliberately makes affirmative assumptions about people and relationships asking deliberate positive questions to ignite formative dialogue [45].

The process of AI starts with a choice of a positive topic. By considering what is, what could be, what will be and what should be, the topic of the research "The endogenous dispute resolution knowledge of the San" was selected. After selection of the topic, a process of confirming the organisational structures, roles and responsibilities of all stakeholders in the research is followed, parallel with a continuous analysis of the context in which these groups will function, in this specific case, the community of Platfontein in historical and demographic context.

AI also requires field researchers to be trained to do conflict mapping, including data collection using content analysis of available data, semi-structured interviews and focus group discussions and to design a conflict map that will display dispute typologies unique to the community.

---

[<sup>40</sup>]Robbins, *op. cit.*

[<sup>41</sup>]Boulle, L., "A History of Alternative Dispute Resolution", *ADR Bulletin*, vol. 7, no. 7, 2005, p.130

[<sup>42</sup>]Ury, W.L. "Conflict Resolution among the Bushmen: Lessons in Dispute Systems Design", *Negotiation Journal* vol. 11, no. 4, October 1995, pp. 379-389.

---

[<sup>43</sup>]Ury, *op. cit.*

[<sup>44</sup>]Cooperrider, D.L.P, Sorensen, P.F. and Whitney, D., Yaeger, T.F. *Appreciative Inquiry. Rethinking Human Organization Toward a Positive Theory of Change*, Illinois, Stipes, 2000.

[<sup>45</sup>] Ludema, J.D., Cooperider, D.L., Barret, F.J., *Appreciative inquiry: The power of the unconditional positive question* in Reason, P. & Bradbury, H. (eds.) *Handbook of Action Research*, Thousand Oaks, CA., Sage, 2000.

## Content analysis

Content analysis is a methodology borrowed from the social sciences for studying the content of any form of communication such as books, websites, paintings and laws [46]. Content analysis is a scholarly methodology by which texts are studied as to authorship, authenticity or meaning [47]. It is any technique for making inferences by identifying objectively and systematically specified characteristics of messages [48].

Qualitative content analysis is used for this study, involving the analysis of the content of video-captured narratives, written text, interviews, categorized and classified according to a research design. Analysis is done manually by systematically analysing written and answers to open ended questions. The input is analyzed for recursive concepts and coded into categories for building up inferences. To make valid inferences from the text, it is important that the classification procedure be consistent: the different people should codify the same text in the same way [49].

The main challenge with capturing narratives is to tap effectively into the rich oral tradition, the stories that the San passed on from generation to generation by word of mouth about the lived experiences in the past, while ensuring that the participant benefits from this voluntary disclosure.

During interviews, focus groups and integrated workshops the spoken memories has to be captured with participants speaking in the language of choice. An interpreter is used if needed. In other words, language of choice is used for capturing, while dissemination will take place in English. Thus, a transcription and translation process will be required before dissemination.

Transcription will be done by the interviewer to ensure that the mood and intent of the interview is captured correctly. However, because transcribing interviews are expensive and time-consuming, it will not be realistic to transcribe complete narratives. Therefore, the researchers will be trained to select responses that directly answer the knowledge questions.

---

[46] Babbie, E.R., *The Practice of Social Research* (12th ed.). Wadsworth, Cengage Learning, 2010,

[47] Joubish, Muhammad Farooq; Muhammad Ashraf Khurram, "Outlook on Some Concepts in the Curriculum of Social Studies", *World Applied Sciences Journal* 12 2011.

[48] Holsti, O. R. *Content Analysis for the Social Sciences and Humanities*, Reading, MA, Addison-Wesley. 1969,

[49] Weber, R.P, *Basic Content Analysis* (2nd ed.). Newbury Park, CA., Sage, 1990.

Suitable information needs to be analysed and synthesised for presentation. The analysis will entails sorting, comparison and integration in order to understand the parts in relationship to the whole. The analysis will be done by establishing relationships between the variables. As the type of information that is dealt with is qualitative, a creative and critical process is necessary. The researchers puts the analysed parts together in a way that depicts a complete picture. This partial analysis can be presented to the larger reference group for reflection and interpretation.[50]

## Conflict analysis

A complete picture should display the results of content analysis and appreciative inquiry, preferably in the form of a chronological and geographical map of the conflict. The conflict map is used as a holistic framework to determine recursive conflict patterns that includes conflict variables such as actors in the conflict; the cultural and global context; causes and consequences; contrasting beliefs and values, goals and interests; conflict dynamics; the types of disputes that occur; prevention of potential disputes and especially processes followed in terms of violence prevention. Accepting that "mapping" a conflict is a *first step* in intervening to manage a particular conflict, two tools were chosen to do conflict mapping: The Conflict Tree and the Conflict Map. [51]

The Conflict Tree [52] is a visual tool used to assist in understanding conflict in terms of its causes and impacts, visualizing the relationship between structural and dynamic factors, The Conflict Tree stimulate group discussions, agreement on the core problem, understanding of the relationship among causes and effects, identifying conflict themes that could and should be addressed. The conflict tree displays the main aspects of a conflict (the trunk), its underlying causes (the roots), and its effects (the branches).

---

[50] Elliott, J. Heesterbeek, S., Lukensmeyer, C.J. Slocum, N.

*Participatory methods toolkit: a practitioner's manual*, Brussels: King Baudouin Foundation and the Flemish Institute for Science and Technology, 2005.

[51] Wehr, P., "Conflict Regulation", *Westview Special Studies in Peace, Conflict, and Conflict Resolution*, Boulder (Colorado), Westview Press. 1979,

[52] Mason, M and Rychard, S., *Conflict analysis tools*, Swiss Agency for Development and Cooperation, Bern, SDC Conflict Prevention and Transformation Division (COPRET), 2005.

The Conflict Map [53] simplifies and displays a conflict on one page, visualising the actors and their “power”/ influence on the conflict, their relationship with each other, and the conflict theme or issues. A Conflict Map represents a specific view point/image of a specific conflict situation, at a specific moment in time.

In the case of the research to determine dispute resolution principles and practices of the community, a combination of the Conflict Tree and Conflict Map will be used and called the Baobab Map (appropriately named so because of the special significance the Baobab tree enjoys in the San culture). This hybrid tool will display the history of conflict of the Platfontein San in time and space, as well as variables such as the origins/causes of the conflict and disputes, the actors involved, the connections between them, the impact of external influences on the community, and how disputes were successfully dealt with by the community to alleviate the impact.

### **Interpretative interaction**

Interpretation of the information will be in the form of an integrated interpretative workshop. Interpretative interaction will involve discourse to interpret reality in social and cultural context.[54]

Critical thinking will involve reflective reasoning about beliefs and actions [55] to decide whether a claim is always true, sometimes true, partly true, or false. It involves a commitment to the social practice of participatory democracy, the willingness to consider alternative perspectives, the willingness to integrate new or revised perspectives into existing ways of thinking and acting, and the willingness to foster critical thinking in others.[56]

During the interpretative interaction, alternatives to the Boabab Map that was created to analyse information, will be encouraged in the form of “Argument Maps” where participants will be required

to draw a visual representation of the informal structure of an argument by using a “box-and-arrow” diagram with boxes corresponding to propositions and arrows corresponding to relationships. The Argument Maps will then be used to deliberate issues, ideas and arguments, which is usually associated with wicked problems such as dispute resolution.[57]

### **Data dissemination[58]**

Findings and recorded stories will be disseminated back to the community during integrated workshops before final dissemination. Copies of recordings will be offered to interviewees. Final dissemination will be in the form of selected video clips and voice recordings accessible by the public through the Web Portal.

During an integrated workshop with the community, the results can be validated by more people and will be more reliable. More people can understand the process of analysis. The group can now discuss the implications of the results. It is expected that new questions will arise that require additional collection of information, that some preliminary findings will be drawn and all participants will learn from the results. It is expected that specific themes will emerge as propositions for further research. Discussion of questions will be encouraged, allowing community members to express their perspectives on how the information should be interpreted.

The emphasis of the conclusions will not be upon success or failure but upon learning. Insights gained from the evaluation process forms part of the iterative learning process that is comprised by participatory assessment, monitoring and evaluation. If additional information is required to answer new questions, the research plan will be revised to gather the needed data. Finally, the group should discuss and decide upon a plan of action, based on the results.

### **Community participation in research: towards new research protocols for dealing with the “first people” of Africa**

---

[53] Fisher, S., Ludin, J., Williams, S., Dekha Ibrahim Abdi, Smith, R and Williams, S. *Working with conflict, skills and strategies for action*, London, Zed books, 2000.

[54] Watzlawick, P., Weakland, J.H., Fisch, R. *Changing a system*. W.W. Norton, New York, (1974).

[55] Ennis, R. H. *A Taxonomy of Critical Thinking Skills and Dispositions* in Baron J. B. and Sternberg R. J. (eds.), *Teaching Thinking Skills: Theory and Practice*, New York, Freeman, 1987.

[56] Raiskums, B.W. *An Analysis of the Concept Criticality in Adult Education*. Capella University, 2008.

---

[57] Facione, P. A. *Think critically*. Upper Saddle River, NJ: Prentice Hall, 2011.

[58] D'Arcy, D. C., “The community's toolbox: The idea, methods and tools for participatory assessment, monitoring and evaluation in community forestry”, *Community Forestry Field Manual 2*, Rome, Food and Agriculture Organization of the United Nations 1990.

### The community-based participatory approach

To implement successfully the above research methodology, a participatory process is required that builds convergences and sustained interaction between formal and informal institutions while empowering community beneficiaries through programmes and projects.[59]

Research must be relevant and beneficiary to the community. Research partnerships should be based on mutual respect and responsibility. Community participation in research includes all aspects of the research processes, including data collection, analysis, and report writing, wherever practical. The aim is to increase understanding about research and to increase skills and capacity within the community.[60]

Research and learning processes should be reciprocal. An implicit understanding about the value of indigenous/endogenous knowledge and research skills should drive the willingness to learn from each other.

All researchers should report to the community, by means of either written and/or oral presentation, in language understandable to community members.

The author recommends that the affected community participate in developing this research methodology and that all parties to a dispute and conflict utilize the conflict map to resolve current disputes.

### General participatory research principles

The general principles for research within or First People should demonstrate the following:

- Cultural respect. Demonstrated toward First People cultures and communities by valuing their diverse knowledge of their environment, as well as their unique worldviews and value systems, and the contribution these make toward knowledge. [61].
- Relevance. Cultural and community is critical for First People training and research.[62]
- Reciprocity. Is accomplished through a two-way process of learning and research exchange. Both

---

[59]Houtondji, loc.cit.

[60]Inter Tribal Health Authority, Research protocol, St Nanaimo,ITHA, 2005.

[61]Kirkness, V.J. and Barnhardt, R., "First nations and higher education: The four R's - respect, relevance, reciprocity and responsibility". Journal of American Indian Education30(3), 1991.

[62]Ibid.

community and learning institutions should benefit from effective training and research relationships.[63]

- Empowerment. Promoted through active and thorough engagement and participation. [64]
- Ownership. Communities and groups own information collectively, in the same way as individuals own personal information. A clear distinction is made between ownership and custodianship of data. [65]
- Control. Recognises First Peoples rights and aspirations to maintain or regain control in all aspects of their lives, including research data. Control includes all stages of a research project [66]
- Access. The recognition that First Peoples have access to information about themselves and their communities, wherever it is held. First People have the right to manage and make decisions regarding access to their collective information [67].
- Respect for human dignity. Regarding individual research participants, to ensure:[68]
  - free and informed consent for all research participants
  - protection of all participants
  - privacy and confidentiality
  - justice in inclusion/exclusion
  - a clear understanding of the potential harms and benefits to individual participants,
  - avoidance and prevention of harm

### References

[1]Casalis, E. *The Basutos (1997 reprint)*. Morija Museum & Archives, Morija, 1861.

[2]Van der Post, L. *The Heart of the Hunter*. London, Hogarth Press, 1961.

---

[63]Ibid.

[64]University of Victoria, Protocols and principles for conducting research in an indigenous context. Victoria, Faculty of Human and Social Development, 2003.

[65]Schnarch, B., Ownership, control, access and possession (OCAP) or self-determination applied to research. Journal of Aboriginal Health 1(1), St Nanaimo,ITHA, 2004.

[66] Ibid.

[67] Ibid.

[68]The Medical Research Council of Canada, Natural Sciences and Engineering Research Council of Canada, and Social Sciences and Humanities Research Council of Canada, Tri-Council Policy Statement: Ethical conduct for research involving humans. Ottawa, Public Works Canada, 1998.

- [3]Robbins, D., *A San Journey: The Story of the !Xun and Khwe of Platfontein*, Kimberley, Sol Plaatjie Educational Trust, 2012.
- [4]Nicolescu, B. *Towards Transdisciplinary Education and Learning*, Philadelphia. Metanexus Institute, 2005.
- [5] Nabudere, D.W., *Afrikology and Trans-disciplinarity: A Restorative Epistemology*, Pretoria, Africa Institute of South Africa, 2012,
- [6] Ingold, T., *Being alive: essays on movement, knowledge and description*, New York, Routledge, 2011.
- [7] Houtondji, P.J, “Knowledge of Africa, knowledge of Africans”, *RCCS Annual Review no. 1*, September 2009, p.10.
- [8]Robbins,D., *op. cit.*
- [9]Robins, S., Madzudzo, E., Brenzinger, M., “Regional assessment of the status of the San in Southern Africa”, *Report series no. 2 of 5*, Windhoek. Legal Assistance Centre, 2001, p.2.
- [10]Robbins, *op.cit.*
- [11] Robbins, *op.cit.*
- [12]Robbins, *op. cit.*
- [13] Boulle, L., “A History of Alternative Dispute Resolution”, *ADR Bulletin*, vol. 7, no. 7, 2005, p.130
- [14] Ury, W.L. “Conflict Resolution among the Bushmen: Lessons in Dispute Systems Design”, *Negotiation Journal* vol. 11, no. 4, October 1995, pp. 379-389.
- [15] Ury, *op.cit.*
- [16] ooperrider, D.L.P, Sorensen, P.F. and Whitney, D.,Yaeger, T.F. *Appreciative Inquiry. Rethinking Human Organization Toward a Positive Theory of Change*, Illinois, Stipes, 2000.
- [17] Ludema, J.D., Cooperider, D.L., Barret, F.J., *Appreciative inquiry: The power of the unconditional positive question* in Reason, P. & Bradbury, H. (eds.) *Handbook of Action Research*, Thousand Oaks, CA., Sage, 2000.
- [18] Babbie,E.R., *The Practice of Social Research* (12th ed.). Wadsworth, Cengage Learning, 2010
- [19] Joubish, Muhammad Farooq; Muhammad Ashraf Khurram, “Outlook on Some Concepts in the Curriculum of Social Studies”, *World Applied Sciences Journal* 12 2011.
- [20] Holsti, O. R. *Content Analysis for the Social Sciences and Humanities*, Reading, MA, Addison-Wesley. 1969,
- [21]Weber, R.P, *Basic Content Analysis* (2nd ed.). Newbury Park, CA., Sage, 1990.
- [22] Elliott,J. Heesterbeek, S.,Lukensmeyer,C.J. Slocum,N. *Participatory methods toolkit: a practitioner’s manual*, Brussels: King Baudouin Foundation and the Flemish Institute for Science and Technology, 2005.
- [23] Wehr,P., “Conflict Regulation”, *Westview Special Studies in Peace, Conflict, and Conflict Resolution*, Boulder (Colorado),Westview Press. 1979
- [24]Mason,M and Rychard,S., *Conflict analysis tools*, Swiss Agency for Development and Cooperation, Bern, SDC Conflict Prevention and Transformation Division (COPRET),2005.
- [25] Fisher, S., Ludin,J., Williams, S., Dekha Ibrahim Abdi, Smith,R and Williams,S. *Working with conflict, skills and strategies for action*, London, Zed books,2000.
- [26] Watzlawick, P., Weakland, J.H., Fisch, R. *Changing a system*. W.W. Norton, New York,(1974.
- [27] Ennis, R. H. *A Taxonomy of Critical Thinking Skills and Dispositions* in Baron J. B. and Sternberg R. J. (eds.), *Teaching Thinking Skills: Theory and Practice*, New York, Freeman, 1987.
- [28] Raiskums, B.W. *An Analysis of the Concept Criticality in Adult Education*. Capella University, 2008.
- [29] Facione, P. A. *Think critically*. Upper Saddle River, NJ: Prentice Hall, 2011.
- [30] D'Arcy,D. C., “The community's toolbox: The idea, methods and tools for participatory assessment, monitoring and evaluation in community forestry”,

*Community Forestry Field Manual 2*, Rome, Food and Agriculture Organization of the United Nations 1990.

[31] Houtondji, loc.cit.

[32] Inter Tribal Health Authority, Research protocol, St Nanaimo, ITHA, 2005.

[33] Kirkness, V.J. and Barnhardt, R., "First nations and higher education: The four R's - respect, relevance, reciprocity and responsibility". *Journal of American Indian Education* 30(3), 1991.

[34] Ibid.

[35] Ibid.

[36] University of Victoria, Protocols and principles for conducting research in an indigenous context. Victoria, Faculty of Human and Social Development, 2003.

[37] Schnarch, B., Ownership, control, access and possession (OCAP) or self-determination applied to research. *Journal of Aboriginal Health* 1(1), St Nanaimo, ITHA, 2004.

[38] Ibid.

[39] Ibid.

[40] The Medical Research Council of Canada, Natural Sciences and Engineering Research Council of Canada, and Social Sciences and Humanities Research Council of Canada, Tri-Council Policy Statement: Ethical conduct for research involving humans. Ottawa, Public Works Canada, 1998.



# A Webpage Emotional Category Determination Methodology based on Color Psychology and Browser's Eye Movement Tracking

Shih-Ting Yang; Chia-Wei Huang

Department of Information Management, Nanhua University,  
[stingyang@mail.nhu.edu.tw](mailto:stingyang@mail.nhu.edu.tw) [g0069003@mail1.nhu.edu.tw](mailto:g0069003@mail1.nhu.edu.tw)

## Abstract

*Due to the convenience of the Internet, people have been accustomed to browsing various types of articles online. Therefore, the emotional change brought by changes in the colors of the webpage is one of the topics worthy of discussion. Although users can browse webpage that are consistent with their emotions from the webpage providers, the current classification technology lacks a color-based webpage emotional classification mechanism. Thus, emotional webpage providers can only rely on their viewpoints to determine the emotional contents and make recommendations to the users. However, by this way, it may result in gap of user perceptions of the webpage due to the subjective judgment of the providers. Meanwhile, previous webpage analysis techniques give the same level of significance to the same data, while lacks consideration on the different levels of significance for the same data contained in different webpage locations due to the user browsing habits. To help emotional webpage providers in the emotional judgment of the webpage from an objective perspective, this paper uses the webpage color configuration to reflect the emotions of the designer in the design of the webpage, and determine the emotions contained in the webpage by referring to the visual focus of the user in browsing webpage and the basis of the browsing sequences. Moreover, this paper develops a Webpage Emotional Category Determination Methodology to help emotional webpage providers in determining the emotional categories of the target webpage.*

**Keywords:** Data Mining, Webpage Classification, Knowledge Management, Color Psychology, Eye Movement Tracking

## 1. Introduction

In the modern society, the pace of life has accelerated, resulting in a stress-filled and stressful life. To relieve pressure and tension in daily lives, most

people adjust their emotions by color configuration in life as perceptions presented by colors are characterized by the impact on psychology and emotions. Psychological and emotional changes can easily affect people's behaviors in life or work. Due to the convenience of the Internet, people have been accustomed to browsing various types of articles online. Therefore, the emotional change brought by changes in the colors of the webpage is one of the topics worthy of discussion. Although users can browse webpage that are consistent with their emotions from the webpage providers, the current classification technology lacks a color-based webpage emotional classification mechanism. Thus, emotional webpage providers can only rely on their viewpoints to determine the emotional contents and make recommendations to the users. However, by this way, it may result in gap of user perceptions of the webpage due to the subjective judgment of the providers. Meanwhile, previous webpage analysis techniques give the same level of significance to the same data, while lacks consideration on the different levels of significance for the same data contained in different webpage locations due to the user browsing habits.

To help emotional webpage providers in the emotional judgment of the webpage from an objective perspective, this paper uses the webpage color configuration to reflect the emotions of the designer in the design of the webpage, and determine the emotions contained in the webpage by referring to the visual focus of the user in browsing webpage and the basis of the browsing sequences. Moreover, this paper developed a "color-based webpage image style determination model" to help emotional webpage providers in determining the emotional categories of the target webpage.

The proposed Webpage Emotional Category Determination Methodology can determine the major blocks of the webpage by using the Webpage Key Block Determination (WKBD) module. Based on the

major blocks, Webpage Emotional Category Determination (WECD) module is used to generate the emotional categories of the webpage.

## **2. Literature Review**

### **(A) Browsers' visual focus and browsing sequence**

For this issue, Wang and Day (2004) used the eye tracker to track the distribution of the attention of the user in browsing meaningful routes to obtain the influence level of the advertisement on the path on the user. The advertisement appeal was adjusted based on the experimental results, namely rational appeals should be adopted at the initial and end periods of the advertisement, and emotional appeals should be used in the midterm. The website information arrangement should be adjusted accordingly. In the initial period, the website information should be able to arouse the interest of the user. In addition, the sequence of placement of major information on the website should be from left to the right, and from top to down. Schiessl et al. (2003) used the eyes tracking system to track the reading sequence of male and female users in viewing the webpage. Subjects were required to look for webpage hyperlinks when they were tracked by eyes tracking system. According to the tracking results, male users mostly browse pictures and rarely browse text contents on webpage. By contrast, female users read carefully the textual contents of the webpage. Hence, the male users are oriented in picture and loose browsing while female users are oriented in precision browsing.

Regarding the users' visual focus in browsing the web documents, Antti et al. (2005) used the eyes movements to explore the webpage areas by testing the treatment group and the control group. The test was aimed to understand the first focus of the user and the area of the webpage of the deepest impression to the user. The areas were known to the treatment group and unknown to the control group. The experimental results showed that, the first focus of the user and deepest impression are all in the blocks on the left of the webpage. Regarding the eye movement tracking of the user on plane advertisement, Rayner et al. (2001) used the eye tracker to record the reading of plane advertisement to obtain the reading sequence of the reader. First, the subjects were required to read the plane advertisement with the purpose of purchasing the advertised product. At the same time, eye tracker was used for recording the track of the eye movements of the user. According to the records, readers simply browse the pictures before reading the text and carefully reading the picture again. The above results

suggested that textual content can help understanding the pictures and the sequence of reading the plane advertisement can be learnt from the above study as well. Rayner et al. (2008) used the eye tracker to record the reading of plane advertisement by subjects divided into two groups. One group of subjects were designed to determine whether the advertisement was interesting or not and the other groups were required to determine the practicability of the advertisement contents. According to the results, it takes more time in browsing pictures as compared to textual contents. In summary of the above results, readers may have different sequences of reading for different purposes in reading the plane advertisement.

Regarding the impact of colors on users' visual focus and browsing sequence, Pearson and Schaik (2002) conducted the repeated measurement experiments of the webpage presentation and link menu colors. In that study, visual search procedure and interactive search procedure were implemented regarding the link measure in repeated measurement to derive the impact of link menu and color on the user. The results showed that blue link menu is apparently more identifiable as compared to a red one. The placement of the link menu on the left or right side of the webpage can be more easily noticeable. Hence, that paper argued that webpage contents should be organized and arranged to enhance the visual search capabilities of the user to realize better webpage use (Pearson and Schaik, 2004).

### **(B) Impact of webpage design on browser**

Regarding the impact of webpage design on browser attention, Hong et al. (2004) discussed the webpage display type (image and text) and information format (horizontal and vertical), and surveyed the impact of the design function on the interaction between user and website. According to the findings, product image display type is better than the textual presentation while the horizontal format is better than the vertical format because it takes less time in search for the image display and horizontal format, and it is easier to remember the product names and pictures (Lee and Benbasat, 2003). In the studies on the webpage design and image, based on the sensibility engineering theory, Wang (2005) listed the user image perceptions as one of the webpage design element. In this way, as designing the webpage, besides the webpage functions, the visual perceptions of the users can also be considered. Hence, the browsers can be satisfied in visual effect and webpage function. That study was conducted in two stages: the first stage was to collect webpage samples and adjectives with

clustering analysis to obtain the representative webpage samples for the experiment and select the representative adjective vocabulary by experimental survey. The second stage was the experiment and regression analysis of the representative framework webpage samples and representative adjective vocabulary. Finally, the webpage design elements that may affect the image style were identified. The user perceptions of webpage images could be learnt from the paper. In addition, design principles were proposed from webpage frame design, design element categories and imagery for the reference of webpage designers in the future.

### **(C) Emotional change of color**

In the papers on the impact of the colors on user emotions, Wexner (1954) studied eight colors and 11 emotions, and found that blue indicates safety, comfort and mildness; red indicates stimulation, protection, revolt and excitement, depression and anxiety; black indicates depression and strength; purple indicates nobility and mysterious; yellow indicates joy and happiness. Adams and Osgood (1973) explored the emotion and color similarity relationships in different cultures, and found that red is a positive or negative emotion, black and gray usually indicate negative emotions, white, blue and green indicate positive emotions. White, gray and yellow colors are weaker while black and red are more intense. In studies relating to children's emotional association and colors, Boyatzis and Varghese (1994) divided 60 children into two groups for survey to ask the children to list their favorite colors, and asked them to view eight different colors and their perceptions. According to the findings, colors indicating positive emotions of the children are the light colors (e.g., pink, blue and red) and colors indicating negative emotions of the children are the dark colors (e.g., brown, black and gray).

In studies on the current mood of the users from the perspective of color psychology, Shugrina et al. (2006) used the facial recognition to learn user expression, touch and image colors to compute the emotions of the expressions. By referring to expression, color emotion and touch, image colors changes were made to get the images consistent with user emotions. In addition, for picture colors, Wang et al. (2004) used the image picture emotional model to explore the main colors of the image pictures, as well as the three-dimensional emotional model to understand the color emotional implications of the image pictures. First, PSO (Particle Swarm Optimization) and Fuzzy C-Means Clustering were used for color segmentation to explore the main colors of the image picture, and classify the picture image color emotional implication through the three-

dimensional emotional model. Based on the regional segmentation, Yang and Peng (2008) used the regional color adjustment and bar chart matching for color fining tuning to allow the users to conduct image color conversion according to mood. In that study, the image picture was analyzed to identify the color bar diagram matching. Next, the users selected the current mood and the color of the picture image was fine-tuned accordingly to obtain the image picture that is consistent with the mood of the user. In the study, the strong and powerful mood represented the red, the mysterious mood represented the purple, the professional mood represented gray and black, the light and brisk mood represented blue and green, the popular, friendly and sunny mood represented yellow; old and stimulation represented red; the brisk and natural mood represented green; the calm and carefree mood represented blue.

Wei et al. (2004) proposed a compact collection of color emotional analysis and secondary categories to judge the movie emotional conversion. In that study, the movie scenes were used to represent colors and the emotions extracted from the movie to determine the overall palette differences, and thus learn the movie emotional conversion.

## **3. Webpage Emotional Category Determination Methodology**

Based on color psychology and browser's eye movement tracking, this paper develops a Webpage Emotional Category Determination Methodology for webpage emotional category determination. This paper first develops the Webpage Key Block Determination (WKBD) module to analyze the key information and contents of the webpage blocks. Secondly, this paper develops the Webpage Emotional Category Determination (WECD) module to determine the emotional categories of target webpage.

### **3.1 Webpage Key Block Determination (WKBD) module**

Based on the Eye Movement Tracking, the proposed Webpage Key Block Determination (WKBD) module is to discuss the viewpoints of webpage browser to obtain the key information presented in the webpage in the browsing sequences of the webpage user. The process of acquiring webpage key information by the browser is discussed below.

#### **3.1.1 Webpage user's viewpoints**

By reference to previous studies, this paper establishes a set of principles for the setting of the

webpage block distribution weight values. Oulasvirta [10] pointed out that the first visual focus of the user and the region of deepest impression on the user in the webpage are blocks on the left of the webpage. Wang [17] analyzed the framework webpage layout design from three perspectives including the structure, layout structure and layout design of the webpage framework. The setting principles are based on the weights in accordance with the block distribution. Finally, this paper determines the target webpage segmentation for the analysis of the webpage blocks distribution. The block weight calculation is shown in Equation (1).

$$ALW_i = \frac{LRT \times \frac{LRW_i}{N(LRW)} + TBT \times \frac{TBW_j}{N(TBW)}}{LRT + TBT} \quad (1)$$

The setting principles are based on the weight values given in accordance with the block distribution. The setting principles can be divided into two parts to determine the weights, respectively, from left to right and from top to bottom. Moreover, if the webpage segmentation is implemented by tag <frameset>, segmentation judgment rule (A) is used. If the segmentation is implemented by unstructured method, segmentation judgment rule (B) is employed. If the segmentation is implemented by using CSS (Cascading Style Sheets), segmentation judgment rule (C) is applied.

**Rule (A): Segmentation by webpage tag <frameset>**

This rule is first to retrieve the <frameset> tagged region in the target webpage  $WD_T$ , and then judge whether the segmentation tag  $PC_m$  exists in the string  $W_{n,k}$  of <frameset> tagged region  $FT_n$ . After confirmation of the existence of segmentation tag, the string  $W_{n,k}$  can then be retrieved with elimination of the tag  $PC_m$  and the operator symbol  $RemS$  to obtain the separation of symbol  $SepS$  after the  $n$ -th segmentation column string  $F_n$ . Furthermore, the segmentation column coefficient  $F_{n,j}$  can be obtained.

**Rule (B): Webpage unstructured segmentation**

This rule is the analysis of the webpage unstructured segmentation (namely, the webpage blocks are not segmented by specified methods including <frameset> and CSS but by tables and line breaks). Target webpage  $WD_T$  is divided into a number of tagged regions  $NR_j$ . DOM Tree architecture (Document Object Model Tree is the presentation of webpage tagged regions in tree structure) consists of multiple block tagged regions  $BNR_q$  ( $q=1, 2, 3, \dots$ ).

Therefore, this rule first retrieve the tagged region of the webpage,  $NR_j$ , and applies the tagged region weighting distribution principles (see Section 3.1) to determine the tagged webpage spatial location  $TR$  before calculating the hierarchical relationship according to the tag spatial location as well as the membership relationships of the tag nodes. In this way, the document object model structure of the target webpage can then be converted.

After completing  $DOM_T$  conversion, this module retrieves the block tag  $BN$  and place it before next block tag  $BN$  (block tag summarized in Table 1) to determine the tagged region  $BNR_q$  contained in the  $q$ 'th block tag. Next, this module calculates the weight of the number of tag nodes of the block tagged region  $BNR_q$  of the  $q$ 'th block tagged region. The calculation of weight takes into consideration all the tag nodes of  $DOM_T$  and number of tag nodes in the  $q$ 'th block tagged region (as shown in Equation 2)). Finally, the distance  $NTD$  between the  $j$ 'th tag node at location  $k$  and the location of the  $l$ 'th tag node in the  $q$ 'th block tagged region can thus be calculated ( $NT_{j,k}, NT_{1,1}$ ) to obtain the minimum distance of  $BNR_q(NT_j)$ . Then, the tag node represents the location of the  $q$ 'th block tagged region (as shown in Equation (3)).

Table 1: Block tag

le	Tit	T ag Type	HTML Tag
B	l	o	<TABLE> 、 <TBODY> 、 <TR> 、 <TD> 、 <TH> 、 <CAPTION> 、 <DIV> 、 <SPAN> 、 <IFRAME>
		ck	<FORM> 、 <FIELDSET> 、 <EGEND> 、 <INPUT> 、 <TEXTAREA> 、 <SELECT> 、 <OPTION> 、 <LABEL>
		tag	<OL> 、 <LI> 、 <UL> 、 <DL> 、 <DT> 、 <DD>

$$WD_T = \{BNR_1, BNR_2, \dots, BNR_q, \dots\}$$

$$DOM_T[BNR_q] = \frac{N(BNR_q)}{N(DOM_T[NT])} \quad (2)$$

$$BNR_q = \left\{ \begin{array}{l} NT_{1,1}, NT_{1,2}, NT_{1,3}, \dots, NT_{1,K}, \dots \\ NT_{2,1}, NT_{2,2}, NT_{2,3}, \dots, NT_{2,k}, \dots \\ \dots, \dots, \dots, \dots, \dots, \dots \\ NT_{j,1}, NT_{j,2}, NT_{j,3}, \dots, NT_{j,k}, \dots \end{array} \right\}$$

$$BNR_q(NT_j) = \underset{All\ k}{MIN} (NTD(NT_{j,k}, NT_{1,1})) \quad (3)$$

$$BNR_{q,j,k} = BNR_q(NT_j)$$

**Rule (C): Webpage CSS (Cascading Style Sheets) segmentation**

This rule is first to retrieve the <head> and <body> tagged regions in the target webpage document. The parts with CSS setting of the <head> tagged region are retrieved as the selector and attribute setting values. As shown in Equation (4), the head tagged region HB is divided into a number of CSS setting sections, EB<sub>i</sub>(SR, PE) (i=1, 2, 3,...). Since CSS (Cascading Style Sheets) provides the selector SR for declaration and attribute setting value PE to set the style of webpage, this rule is to retrieve the tag corresponding to the selector declaration variable VA<sub>i</sub> in the retrieved CSS setting section to calculate the attribute setting value PE and number of setting values N (PE<sub>i</sub>), and further determine the corresponding number of setting values of the tagged region as shown in Equation (5).

In addition, this rule converts the <body> tagged region into document object model structure to determine the tag nodes NT<sub>j,k</sub> and block tagged region BNR<sub>q</sub>. Next, by using the selector declaration variable VA<sub>i</sub> in the i-th CSS setting section, this module matches and compares all tagged nodes NT<sub>j,k</sub>, and determines the number of setting values in the CSS setting section corresponding to the tagged node N(PE<sub>i</sub>). Finally, it modifies the weight of the proportion of the number of tag nodes in the q-th block tagged region N(BNR<sub>q</sub>) against the number of tag nodes in DOM<sub>T</sub> N(DOM<sub>T</sub>[NT]), the DOM<sub>T</sub>[BNR<sub>q</sub>]. In this way, the total weight of the q-th block tagged region DW<sub>T</sub> [BNR<sub>q</sub>] can be derived in Equation (6).

Table 2: Segmentation calculations of CSS

Calculation	Equation	N
CSS setting region analysis	$HB = \{EB_1(SR, PE), EB_2(SR, PE), \dots, EB_i(SR, PE), \dots\}$ $SR_i = \begin{cases} 1 & \text{IF } W_i[EB_i] = '.' \\ 2 & \text{IF } W_i[EB_i] = '#' \\ 3 & \text{otherwise} \end{cases}$	(4)

# of tagged region	$VA_i = \begin{cases} EB_i(SR) - W_i[EB_i] & \text{IF } SR_i = 1 \\ EB_i(SR) & \text{IF } SR_i = 3 \end{cases}$ $EB_i(PE) = \{PE_{i,1}, PE_{i,2}, \dots, PE_{i,j}, \dots\}$	(5)
Tagged region weight	$DW_i[BNR_q] = \begin{cases} DOM_T[BNR_q] \times N(PE_i) & \text{IF } VA_i \neq \phi \forall i, \forall q \\ DOM_T[BNR_q] & \text{otherwise} \end{cases}$	(6)
g value		

**3.1.3 Weight distribution in the Viewpoints of Webpage Browser**

By calculating the viewpoints of the webpage browser, this paper identifies the key blocks and weights to obtain information regarding the important blocks. First, from the viewpoints of the webpage user, this paper determines the block distribution location weights, the block distribution of the target webpage and other important webpage data to implement calculation according to different segmentation rules. Hence, the three calculations are summarized as below. (1) When the target webpage is segmented into blocks according to segmentation Rule (A), Equation (7) is employed to calculate the block distribution and block area weight. (2) When the target webpage is segmented into blocks according to segmentation Rule (B), Equation (8) is employed to calculate the block distribution and the weight of the number of tag nodes in the blocks. (3) When the target webpage is segmented into blocks according to segmentation Rule (C), Equation (9) is employed to calculate the block distribution and the weight of the setting values of CSS corresponding to the blocks. Finally, after obtain the weight values of the blocks in the target webpage, Equation (10) is employed to normalize the weight values of the blocks of the target webpage (as shown in Table 3).

Table 3: Weighting value calculation

Weight Calculation	Equation	N
Rule (A)	$ALW_i = \frac{FW_m}{LRT \times \frac{MAX_H \times MAX_w}{N(LRW)}} \times \frac{LRT + TBT}{FL_m \times TBW_j}$ $+ \frac{TBT \times \frac{MAX_H \times MAX_w}{N(TBW)}}{LRT + TBT}$	(7)

Rule (B)	$TBB_k = TBT \times \frac{TBW_j}{N(TBW)} \forall j$ $ALW_1 = \frac{LRT}{LRT + TBT}$ $\frac{BNR_{q,j,k} \times DOM[BNR_q] \times LRW}{N(LRW)}$ $\times \frac{LRT + TBT}{LRT + TBT}$ $+ \frac{TBB_k}{LRT + TBT} \forall j$	(8)
Rule (C)	$TBB_k = TBT \times \frac{TBW_j}{N(TBW)} \forall j$ $ALW_1 = \frac{LRT}{LRT + TBT} \forall j$ $\frac{BNR_{q,j,k} \times DW[BNR_q] \times LRW}{N(LRW)}$ $\times \frac{LRT + TBT}{LRT + TBT}$ $+ \frac{TBB_k}{LRT + TBT} \forall j$	(9)
Normalized	$Rnt_1[WD_\tau] = \frac{ALW_1}{\sum_{ALL\ 1} ALW_1}$	(10)

### 3.2 Webpage Emotional Category Determination (WECD) module

The proposed Webpage Emotional Category Determination (WECD) module is to first collect the data of color codes from the tagged region. Then, this module determines whether the color code is the RGB code. If it is the RGB code, the color code and the analysis coefficients of major analysis colors (major analysis colors are as show in Table 4) to determine that the target color is close to specified major analysis color; otherwise, the target color code conversion is carried out.

Table 4: Major analysis colors

Color		Hexadecimal			Emotion
No.	Name	R	G	B	
C <sub>1</sub>	Red	55	20	0	Exciting
C <sub>2</sub>	Green	0	255	0	peace
C <sub>3</sub>	Blue	0	0	255	Relax
C <sub>4</sub>	Yellow	255	255	0	Happiness
C <sub>5</sub>	Cyan	0	255	255	Relax
C <sub>6</sub>	Purple	255	0	255	Mystery

C <sub>6</sub>	Black	55	55	55	Depressed
C <sub>7</sub>	Black	0	0	0	
C <sub>8</sub>	White	255	255	255	Simple

#### Step (E1): Color code extraction and conversion into RGB code

With the tagged region of the webpage as the basis for analysis, Step (E1) establishes the color code database for the judgment of color code. Then, the color codes of the target webpage are extracted to compare with the color code database to judge whether the color code is RGB code. If the color code is RGB code, it is intercepted. Otherwise, it is converted into RGB code. Finally, after the interception of RGB code, the conversion coefficients are obtained for red, green and blue respectively. The details of this Step are illustrated as below:

**Step (E1.1) Color code input:** Establish the color code database and input color code.

**Step (E1.2) Color code analysis:** Retrieve the webpage color strings and eliminate the symbol character “.”, and break down the string into the color code (#FF0000) and text string (color).

**Step (E1.3) Color code judgment:** Determine whether the color code is RGB code (#FF0000), if it is RGB code, then go to Step (E1.5), otherwise, go to Step (E1.4).

**Step (E1.4) Color code comparison:** Match the color code with color code database, if it belongs to the color code database, then extract the RGB code data of the character set.

**Step (E1.5) Color code interception:** Intercept the extracted RGB color code, and name the sections from W<sub>1</sub> to W<sub>6</sub>.

**Step (E1.6) Color code conversion:** Groups of two of W<sub>1</sub>, W<sub>2</sub>, W<sub>3</sub> to W<sub>6</sub> represent the conversion coefficients for red, green and blue (as shown in Equation (11)).

$$\begin{aligned}
C_T &= 'W_1'+ 'W_2'+ 'W_3'+ 'W_4'+ 'W_5'+ 'W_6' \\
DC_r &= 'W_1'+ 'W_2' \\
DC_g &= 'W_3'+ 'W_4' \\
DC_b &= 'W_5'+ 'W_6' \\
TC(C_T, DC_r) &= V[W_1] \cdot 16^1 + V[W_2] \cdot 16^0 \\
TC(C_T, DC_g) &= V[W_3] \cdot 16^1 + V[W_4] \cdot 16^0 \\
TC(C_T, DC_b) &= V[W_5] \cdot 16^1 + V[W_6] \cdot 16^0 \\
\text{where IF } W_i &= \begin{cases} A \text{ THEN } V[W_i] = 10 \\ B \text{ THEN } V[W_i] = 11 \\ C \text{ THEN } V[W_i] = 12 \\ D \text{ THEN } V[W_i] = 13 \\ E \text{ THEN } V[W_i] = 14 \\ F \text{ THEN } V[W_i] = 15 \end{cases} \quad (11) \\
, \forall i &= 1, 2, 3, 4, 5, 6
\end{aligned}$$

**Step (E2): Calculate the analysis coefficients of target color code and major analysis color**

At this Step, the target color code  $C_T$  and the conversion coefficients of color red  $DC_r$ , green  $DC_g$ , blue  $DC_b$ , and the coefficients after the conversion  $DC_r$  for red,  $DC_g$  for green and  $DC_b$  for blue are input in Group 1 to calculate the target color codes are close to the major analysis colors of red ( $MC_1$ ), green ( $MC_2$ ), and blue ( $MC_3$ ). If the maximum analysis coefficient is not more than the threshold value (66%), the target color code may belong to the major analysis colors of yellow ( $MC_4$ ), purple ( $MC_5$ ), and cyan ( $MC_6$ ) and calculated in the Group 2. In addition, if the coefficients of the three colors equal, then the coefficients are calculated by the Group 3. It has been preliminarily judged that the target webpage is close to the analysis coefficient of the major analysis color  $TA(C_T, MC_n)$ . Finally, by referring to the weight of the color code tag located in the key block  $Rnt_i[WD_T]$  and the analysis coefficient  $TA(C_T, MC_n)$ , the weighted color category coefficient  $Rct_n[WD_T]$  can be calculated in Equation (12).

$$\begin{aligned}
Rct_n[WD_T] &= \sum_{\text{all } i} TA(C_i, MC_n) \\
&\quad \times Rnt_i[WD_T] \quad (12)
\end{aligned}$$

**Step (E3): Normalization of the color codes contained in the target webpage**

At this Step, since the color groups contained in the different colors of the target webpage are different, this paper normalizes the analysis coefficients of Group 1, Group 2 and Group 3 contained in the target webpage (as shown in Equation

(13)). After that, the color category coefficient  $Rct_n[WD_T]$  can be obtained. Greater  $Rct_n[WD_T]$  indicates that the target webpage is closer to the emotions corresponding to the major analysis colors; if  $Rct_n[WD_T]$  is 0, it indicates that target webpage and major analysis colors have no relevance.

$$Rct_n[WD_T] = \frac{Rct_n[WD_T]}{\sum_{\text{all } n} Rct_n[WD_T]} \quad (13)$$

The main title (on the first page) should begin 1-3/8 inches (3.49 cm) from the top edge of the page, centered, and in Times 14-point, boldface type. Capitalize the first letter of nouns, pronouns, verbs, adjectives, and adverbs; do not capitalize articles, coordinate conjunctions, or prepositions (unless the title begins with such a word). Leave two 12-point blank lines after the title.

**4. Webpage Emotional Category Determination System**

The common users can upload the web documents to be classified through the webpage maintenance module. As shown in Figure 1, for example, the common user uploads the webpage entitled “counterstrike, Microsoft Windows 8 system open for downloading”, which is categorized as “technology”, and keywords including “Tablet PC”, “software”, and “operating system”. Then, the common user can browse the uploaded web document and review the webpage classification results. The system administrator can set the system weights in advance through the system weight maintenance module including tag weight and block distribution weight, namely, setting the weight of the block distribution level “9” as “0” (as shown in Figure 2). The system administrator can select the webpage to be classified by using the webpage emotion category determination function. This system first computes the weight values of the key blocks in the target webpage, namely, the weight of the key block of “web document block 1” in the target webpage is “46%” (as shown in Figure 3). It then uses the webpage emotional category determination module to convert the webpage color tags into the RGB codes (as shown in Figure 4, the color tag “indianred2” is converted into RGD code of “238, 99, 99”). Then, the webpage emotional category determination module can compute the webpage and main analysis coefficients to generate the result that the webpage’s emotional category “joy” coefficient is “60%” (as shown in Figure 5).





Figure 1: Webpage upload



Figure 2: Block distribution weight set



Figure 3: Key block weight set



Figure 4: Color code conversion



Figure 5: Webpage emotional category determination

## 5. Conclusions

To help emotional webpage providers in determining the webpage emotions from the perspective of users, this paper proposed a Color-based Webpage Image Style Judgment Model for webpage providers. This proposed model consists of two major modules including Webpage Key Block Determination (WKBD) and Webpage Emotional Category Determination (WECD) modules. Based on browsers' visual focus and browsing sequence, key blocks of the webpage can be obtained. Based on color psychology, the color distribution of the webpage, and the major colors of the webpage can be determined to generate the emotional categories of the target webpage. Finally, through developed system, the emotional webpage providers can determine the webpage emotions more objectively and provide the webpage consistent with demanders' emotional state to the users.

## 6. References

- [1] A. Oulasvirta, L. Kärkkäinen and J. Laarni, "Expectations and Memory in Link Search," *Computers in Human Behavior*, Vol. 21, No. 5, 2005, pp. 773-789.
- [2] C. Boyatzis and R. Varghese, "Children's Emotional Associations with Colors." *Journal of Genetic Psychology*, Vol. 155, No. 1, 1994, pp. 77-85.
- [3] C.C. Wang, "A Study on Layout of Frame-Type and Image in Webpage," *Department of Graphics Arts and Communications, National Taiwan Normal University, Master Thesis*, 2005.
- [4] C.K. Yang, and L.K. Peng, "Automatic Mood-Transferring Between Color Images," *IEEE Computer Graphics and Applications*, Vol. 28, No. 2, 2008, pp.

52-61.

[5] C.Y. Wei, N. Dimitrova and S.F. Chang, "Color-Mood Analysis of Films based on Syntactic and Psychological Models," *IEEE International Conference on Multimedia and Expo*, Vol. 2, 2004, pp. 831-834.

[6] F.M. Adams, and C.E. Osgood, "A Cross-cultural Study of the Affective Meanings of Color." *Journal of Cross-Cultural Psychology*, Vol. 4, No. 2, 1973, pp 135-156.

[7] H.S. Park, and S.J. Noh, "Enhancement of Web Design Quality through the QFD Approach," *Total Quality Management*, Vol. 13, No. 3, 2002, pp. 393-401.

[8] K. Rayner, B. Miller, and C.M. Rotello, "Eye Movements When Looking at Print Advertisements: The Goal Of The Viewer Matters," *Applied Cognitive Psychology*, Vol. 22, No. 5, 2008, pp. 697-707.

[9] K. Rayner, C.M. Rotello, A.J. Stewart, J. Keir and S.A. Duffy, "Integrating Text and Pictorial Information: Eye Movements When Looking at Print Advertisements," *Journal of Experimental Psychology-Applied*, Vol. 7, No. 3, 2001, pp. 219-226.

[10] K. Wei, B. He, T. Zhang and W. He, "Image Emotional Classification based on Color Semantic Description," *Lecture Notes in Computer Science*, Vol. 5139, 2008, pp. 485-491.

[11] L.B. Wexner, "The Degree to Which Colors (Hues) are Associated with Mood-Tones," *Journal of Applied Psychology*, Vol. 38, No. 3, 1954, pp. 432-435.

[12] M. Schiessl, S. Duda, A. Thölke and R. Fischer, "Eye tracking and its application in usability and media research," *Mensch-Maschine-Interaktion*, Vol. 6, 2003, pp. 41-50.

[13] R. Pearson and P.V. Schaik, "The Effect of Spatial Layout of and Link Colour in Web Pages on Performance in a Visual Search Task and an Interactive Search Task," *International Journal of Human-Computer Studies*, Vol. 59, No. 3, 2003, pp. 327-353.

[14] Shugrina, M., Betke, M. and Collomosse, J., 2006, "Empathic painting: Interactive stylization through observed emotional state," *Non-photorealistic Animation and Rendering*, Vol. 6, pp. 87-96.

[15] W. Hong, J.Y.L. Thong and K.Y. Tam, "Designing Product Listing Pages on E-Commerce Websites: An Examination of Presentation Mode and Information Format," *International Journal of Human-Computer Studies*, Vol. 61, 2004, pp. 481-503.

[16] W. Lee and I. Benbasat, "Designing an Electronic Commerce Interface: Attention and Product Memory as Elicited by Web Design." *Electronic Commerce Research and Applications*, Vol. 2, No. 3, 2003, pp. 240-253.

[17] Y.C. Wang and R.F. Day, "The Effects of Attention Inertia on Advertisements on the WWW," *Computers in Human Behavior*, Vol. 23, No. 3, 2007, pp. 1390-1407.

# An EOQ model with freight rate linked to order quantity and two-part trade credit

Chia-Huei Ho \*

Department of Business Administration, Ming Chuan University  
[chho@mail.mcu.edu.tw](mailto:chho@mail.mcu.edu.tw)

Liang-Yuh Ouyang

Department of Management Sciences  
Tamkang University  
[liangyuh@mail.tku.edu.tw](mailto:liangyuh@mail.tku.edu.tw)

Chia-Hsien Su

Department of Business Administration  
Tungnan University  
[peony@mail.tnu.edu.tw](mailto:peony@mail.tnu.edu.tw)

## Abstract

*Trade credit and freight rate discounts are often adopted as marketing strategies by suppliers to drive larger order size. Also, trade credit is an important proportion of company finance especially for small businesses. However, the retailer's carrying cost increase for holding large quantities of inventory. In this paper, a trade-off from trade credit and freight rate discounts is focused. An economic ordering quantity (EOQ) model is developed, wherein the market demand is sensitive to the selling price. A shipping-quantity-dependent freight cost and a two-part trade credit are offered by the supplier. The solution procedures are provided for finding the optimal pricing, order quantity, as well as shipment and payment policies, and illustrated with numerical examples. The sensitivity of the optimal results with respect to those parameters which directly influence the retailer's performance is also examined.*

## 1. Introduction

Trade credit is a widely observed pricing strategy for improving the profitability and cost effectiveness in sales (Mateut et al. [1], Guariglia and Mateut [2], Ge and Qiu [3]). Businesses, especially small businesses, with limited financing opportunities, may be financed by their suppliers rather than by financial institutions (Petersen and Rajan [4]). Suppliers offer a trade credit as an incentive to increase sales and reduce stock, and the retailer can use the sale revenue to benefit without interest charged during the credit period. Goyal [5] is the first one who developed an EOQ model under the condition of permissible delay in payments. Subsequent numerous studies on trade credit have been published, such as Ouyang et al. [6], Chung and Liao [7], Teng [8], Tripathi et al. [9], Khanra et al. [10], and

Musa and Sani [11]. The above papers assume that the supplier offers a fixed credit period to the retailer. From the supplier's perspective, offering trade credit can stimulate the demand. However, from another viewpoint, offering trade credit leads to delayed cash inflow and increases the risk of cash flow shortage and bad debt. Therefore, in order to accelerate cash inflow and reduce the risk of bad debt, the supplier may provide a cash discount to encourage the retailer to pay for goods quickly. In other words, the supplier offers a delayed payment credit period and early payment cash discount to the retailer. This type of trade credit is called a two-part trade credit policy. There are more papers related to two-part trade credit policy such as Ouyang et al. [12], Huang and Goyal [13], Goyal et al. [14], Sana and Chaudhuri [15], and Yang [16].

Transportation costs form a critical part of the total logistics costs of a commodity (Ertogral et al. [17]). Given today's intense market competition, an appropriate transportation cost function should be included into lot-sizing modeling. Tersine and Toelle [18] first established an economic inventory-transport model with freight discounts. The models proposed by Lee [19], Hwang et al. [20] and Tersine and Barman [21] combined freight discounts with all-unit or incremental discounts. Russell and Krajewski [22] presented an analytical approach to find the optimal order quantity that minimizes total purchase costs which reflects both transportation economies and quantity discounts. Swenseth and Godfrey [23] proposed a model in which two freight rate functions, the inverse and the adjusted inverse, were incorporated into the total annual logistics cost function to determine the impact on purchasing decisions. Then, Abad and Aggarwal [24] presented a model which allows for over-declaring of the weight of the shipment and for less-than-truckload or truckload

size shipments. There are more studies regarding transportation costs such as Rieksts and Venturab [25], Viau et al. [26], Rieksts and Ventura [27], Choudhary and Shankar [28], and Tsao and Lu [29].

Both trade credit and freight rate discount are common practice in today's business world, hence, we should consider both of them simultaneously in the ordering decision model. Shinn et al. [30] formulated the retailer's optimal purchase lot size problem with freight discounts allowed under the conditions of a permissible delay in payments. Sheen and Tsao [31] proposed a single-supplier single-retailer integrated model with trade credit and freight cost. Ouyang et al. [32] continued to discuss an integrated inventory system when both freight rate and trade credit are linked to the order quantity. Lately, Tsao and Sheen [33] extended Sheen and Tsao's [31] model by proposing a multi-item integrated inventory model with delay payment and freight rate discount. Chung [34] further proposed an integrated inventory model with trade credit and transportation cost. The credit policy applied in this paper is a two-level trade credit policy, that is, both supplier and retailer offer delay payment. The trade policy applied in the above papers is a "one-part" trade credit. That is, the suppliers offer only delay payment to retailers, early payment cash discount is not considered.

Consequently, in order to investigate the effects of transportation and trade credit issues on inventory decisions, an inventory model with a retail price sensitive demand under a "two-part" trade credit and freight rate discounts is developed. The supplier offers a cash discount if payment is made before a specified period, otherwise full purchasing price must be paid before the delay payment due date. It is assumed that the freight costs are related to the lot sizing decisions. To save money on the shipping cost by arranging for the freight itself, a batch quantity is ordered and then splits it into several equal-size shipments as needed. The goal of this research is to determine the optimal payment policy, retail price, order quantity, and number of shipments in order to maximize the total profit per unit time. An algorithm is designed to determine the optimal policy. Numerical examples are presented to illustrate the theoretical results. Furthermore, the sensitivity of the optimal solutions with respect to some parameters is also examined.

## 2. Notations and assumptions

The following notations and assumptions were made in developing the proposed inventory model.

### 2.1. Notations

$Q$	ordering size per order
$S$	ordering cost per order
$v$	unit purchasing cost
$p$	unit retail price, and $p > v$
$D$	the market demand rate per unit
$(p)$	time
$h$	fixed shipping cost per shipment
$F_i$	unit shipping cost dependent on shipment size, $i = 0, 1, 2, \dots, m$
$r$	holding cost rate excluding interest charges
$I_e$	the interest earned per dollar per unit time, $I_e > 0$
$I_p$	the interest paid per dollar per unit time, $I_p > 0$
$\beta$	cash discount offered by supplier
$n$	number of shipment per order
$T$	inventory cycle length per shipment

### 2.2. Assumptions

(1) We consider the problem of single product, and shortages are not allowed.

(2) The credit period set by the supplier is  $M_2$ . In order to speed up cash inflow and reduce the risk of cash flow shortage, the supplier offers a discount,  $\beta$  ( $0 < \beta < 1$ ), off the purchasing price, if the retailer's payment is made within time  $M_1$ , where  $M_2 > M_1 > 0$ . That is, the retailer's unit purchasing cost is  $(1 - k_j \beta)v$ , where  $k_1 = 1$  and  $k_2 = 0$ , based on the payment time at  $M_1$  or  $M_2$ .

(3) During the credit period (i.e.,  $M_1$  or  $M_2$ ), the retailer sells the items and uses the sales revenue to earn interest at a rate of  $I_e$ . At the end of this period, the retailer pays off all purchasing cost to the supplier and incurs a capital opportunity cost at a rate of  $I_p$  for the items in stock.

(4) The market demand rate for the item is a downward sloping function of the retail price and is given by  $D(p) = ap^{-\delta}$ , where  $a > 0$  is a scaling factor, and  $\delta > 1$  is a price-elasticity coefficient. For notational simplicity,  $D(p)$  and  $D$  will be used interchangeably in this paper.

(5) The transportation fee charged by the supplier includes a fix cost  $h$  per shipment and a variable cost,  $F_i$ , according to the shipment quantity. Let  $q$  denotes the shipping quantity per shipment, then the unit shipping cost is defined as follows:

$$\text{unit shipping cost} = \begin{cases} F_0 & \text{for } q_0 \leq q < q_1, \\ F_1 & \text{for } q_1 \leq q < q_2, \\ \vdots & \vdots \\ F_m & \text{for } q_m \leq q < q_{m+1}, \end{cases}$$

where  $F_0 > F_1 > \dots > F_{m-1} > F_m$ , and  $0 = q_0 < q_1 < \dots < q_m < q_{m+1} = \infty$  is the sequence of price-break quantities.

### 3. Model formulation

The total profit per unit time consists of the following elements:

(1) Sales revenue per unit time  $= pD$ .

(2) Purchasing cost per unit time  $= (1 - k_j\beta)vD$ .

(3) Ordering cost per unit time: The retailer orders  $Q$  units in each order, and ask the supplier delivers the order quantity in  $n$  shipment. Therefore, the inventory cycle length per shipment is  $T = Q/(nD)$ . Consequently, the ordering cost per unit time is  $S/(nT) = DS/Q$ .

(4) Carrying cost per unit time (excluding interest charges): The unit purchasing cost is  $(1 - k_j\beta)v$ , the carrying cost rate excluding interest charges is  $r$ , and the average inventory over each shipping cycle is  $Q/(2n)$ . Hence, the carrying cost per unit time, without the time value of the capital tied up in inventories, is  $r(1 - k_j\beta)vQ/(2n)$ .

(5) Transportation cost per unit time: For each delivery quantity  $Q/n \in [q_i, q_{i+1}]$ , The shipping cost per shipment is  $h + F_i Q/n$ . Therefore, the shipping cost per unit time is  $(h + F_i Q/n)/T = D(nh/Q + F_i)$ .

(6) Interest earned and capital opportunity cost per unit time: As the payment is done before or after the total depletion of inventory, there are two cases in interest earned and capital opportunity cost per unit time.

**Case 1:**  $T \uparrow M_j$  (i.e.,  $Q \downarrow nDM_j$ ),  $j = 1, 2$

In this case, the payment time ends on or after the inventory is depleted completely. Hence, opportunity cost does not occur. At the same time, the sales revenue can be used to earn interest at a rate of  $I_e$ , thus, the interest earned per unit time is

$$\begin{aligned} & \frac{1}{T} \left[ pI_e \int_0^T Dt dt + pI_e DT(M_j - T) \right] \\ & = pI_e D \left( M_j - \frac{T}{2} \right) = pI_e D \left( M_j - \frac{Q}{2nD} \right) \end{aligned} \quad (1)$$

**Case 2:**  $T \_ M_j$  (i.e.,  $Q \_ nDM_j$ ),  $j = 1, 2$

This case indicates that the payment time ends on or before the inventory is depleted completely. During the credit period, the sales revenue can be used to earn interest at a rate of  $I_e$ . Hence, the interest earned per unit time is

$$\frac{pI_e}{T} \int_0^{M_j} Dt dt = \frac{npI_e (DM_j)^2}{2Q}$$

Moreover, if some items remain on hand at the due date  $M_j$ , the capital opportunity cost per unit time is

$$\begin{aligned} & \frac{(1 - k_j\beta)vI_p}{T} \int_{M_j}^T D(T - t) dt \\ & = \frac{(1 - k_j\beta)vI_p (Q - nDM_j)^2}{2nQ} \end{aligned} \quad (2)$$

Therefore, for the given delivery quantity  $Q/n \in [q_i, q_{i+1}]$ , the total profit per unit time is the sales revenue adds the interest earned, minus the total relevant costs (which consists of the purchasing cost, ordering cost, carrying cost excluding interest charges, transportation cost and opportunity cost), that is

$$TP_{ji}(n, p, Q) = \begin{cases} TP_{j1i}(n, p, Q), & \text{if } Q \leq nDM_j \\ TP_{j2i}(n, p, Q), & \text{if } Q \geq nDM_j \end{cases} \quad (3)$$

$j = 1, 2$ , where

$$\begin{aligned} TP_{j1i}(n, p, Q) & = pD - (1 - k_j\beta)vD - \frac{DS}{Q} - \frac{(1 - k_j\beta)vrQ}{2n} \\ & - D \left( \frac{nh}{Q} + F_i \right) + pI_e D \left( M_j - \frac{Q}{2nD} \right), \end{aligned} \quad (4)$$

$$\begin{aligned} TP_{j2i}(n, p, Q) & = pD - (1 - k_j\beta)vD - \frac{DS}{Q} - \frac{(1 - k_j\beta)vrQ}{2n} \\ & - D \left( \frac{nh}{Q} + F_i \right) + \frac{npI_e (DM_j)^2}{2Q} \\ & - \frac{(1 - k_j\beta)vI_p (Q - nDM_j)^2}{2nQ}. \end{aligned} \quad (5)$$

It can be shown that  $TP_{j1i}(n, p, nDM_j) = TP_{j2i}(n, p, nDM_j)$ , hence  $TP_{ji}(n, p, Q)$  is continuous for  $Q > 0$  and fixed  $n$  and  $p$ . The problem now is to determine the optimal values of  $n$ ,  $p$  and  $Q$  such that  $TP_{ji}(n, p, Q)$ ,  $j = 1, 2$  and  $i = 1, 2, \dots, m$  in (3) is maximized.

### 4. Solution procedure

Taking the second-order partial derivative of Equations (4) and (5) with respect to  $n$ , we obtain

$$\frac{\partial^2 TP_{j1i}(n, p, Q)}{\partial n^2} < 0, \quad (6)$$

and

$$\frac{\partial^2 TP_{j2i}(n, p, Q)}{\partial n^2} < 0, \quad (7)$$

for  $j = 1, 2$  and  $i = 1, 2, \dots, m$  respectively. It implies that for fixed  $p$  and  $Q$ ,  $TP_{ji}(n, p, Q)$  is a concave function in  $n$ . This ensures that the search for the optimal shipment number,  $n^*$ , is reduced to find a local optimal solution.

#### Determination of the retailer's optimal order quantity for given $n$ and $p$

For given  $n$  and  $p$ , the first-order and second-order partial derivatives of  $TP_{j1i}(n, p, Q)$  and  $TP_{j2i}(n, p, Q)$  with respect to  $Q$  are as follows:

$$\frac{\partial TP_{j1i}(n, p, Q)}{\partial Q} = \frac{D(S+nh)}{Q^2} - \frac{(1-k_j\beta)vr + pI_e}{2n}, \quad (8)$$

$$\frac{\partial^2 TP_{j1i}(n, p, Q)}{\partial Q^2} = -\frac{2D(S+nh)}{Q^3} < 0, \quad (9)$$

$$\frac{\partial TP_{j2i}(n, p, Q)}{\partial Q} = -\frac{(1-k_j\beta)v(r+I_p)}{2n} + \frac{2D(S+nh) + n(DM_j)^2[(1-k_j\beta)vI_p - pI_e]}{2Q^2}, \quad (10)$$

$$\frac{\partial^2 TP_{j2i}(n, p, Q)}{\partial Q^2} = \frac{2D(S+nh) + n(DM_j)^2[(1-k_j\beta)vI_p - pI_e]}{Q^3}. \quad (11)$$

From (9),  $TP_{j1i}(n, p, Q)$  is a concave function in  $Q$  for fixed  $n$  and  $p$ . Consequently, there exists a unique value of  $Q$ , denoted as  $Q_{j1}(n, p)$ , which maximizes  $TP_{j1i}(n, p, Q)$ .  $Q_{j1}(n, p)$  can be obtained by setting (8) equal to zero, and is given by

$$Q_{j1}(n, p) = \sqrt{\frac{2nD(S+nh)}{(1-k_j\beta)vr + pI_e}}. \quad (12)$$

Note that  $Q_{j1}(n, p)$  in Eq. (12) is independent with the unit shipping cost  $F_i$ . To ensure  $Q_{j1}(n, p) \uparrow nDM_j$ , we substitute (12) into inequality  $Q_{j1}(n, p) \uparrow nDM_j$ , and obtain

$$\begin{aligned} &\text{if and only if } Q_{j1}(n, p) \uparrow nDM_j, \\ &\text{then } S+nh \leq \frac{nDM_j^2}{2} [(1-k_j\beta)vr + pI_e]. \quad (13) \end{aligned}$$

Substituting (12) into (4), the total profit per unit time for Case 1 is as follows:

$$\begin{aligned} TP_{j1i}(n, p) &\equiv TP_{j1i}(n, p, Q_{j1}(n, p)) \\ &= D[p(1+I_eM_j) - (1-k_j\beta)v - F_i] \\ &\quad - \sqrt{\frac{2D(S+nh)}{n}} [(1-k_j\beta)vr + pI_e]. \quad (14) \end{aligned}$$

Similarly, by setting the equation (10) equal to zero, we obtain the solution of  $Q$  (denoted by  $Q_{j2}(n, p)$ ) which is given by

$$Q_{j2}(n, p) = \sqrt{\frac{nD\{2(S+nh) + nDM_j^2[(1-k_j\beta)vI_p - pI_e]\}}{(1-k_j\beta)v(r+I_p)}}. \quad (15)$$

Note that  $Q_{j2}(n, p)$  in Eq. (15) is independent with the unit shipping cost  $F_i$ . To ensure  $Q_{j2}(n, p) \uparrow nDM_j$ , we substitute (15) into inequality  $Q_{j2}(n, p) \uparrow nDM_j$ , and obtain

$$\begin{aligned} &\text{if and only if } Q_{j2}(n, p) \uparrow nDM_j, \\ &\text{then } S+nh \geq \frac{nDM_j^2}{2} [(1-k_j\beta)vr + pI_e]. \quad (16) \end{aligned}$$

It note that when  $S+nh \geq \frac{nDM_j^2}{2} [(1-k_j\beta)vr + pI_e]$ , we have

$$\begin{aligned} &2(S+nh) + nDM_j^2[(1-k_j\beta)vI_p - pI_e] \\ &> nDM_j^2(1-k_j\beta)v(r+I_p) > 0, \quad (17) \end{aligned}$$

which implies  $Q_{j2}(n, p)$  in (15) is well defined and  $\partial^2 TP_{j2i}(n, p, Q) / \partial Q^2 < 0$ . Therefore, for fixed  $n$  and  $p$ ,  $Q_{j2}(n, p)$  in (15) is the optimal value which maximizes  $TP_{j2i}(n, p, Q)$ . Substituting (15) into (5), we can get the total profit per unit time for Case 2 as follows:

$$\begin{aligned} TP_{j2i}(n, p) &\equiv TP_{j2i}(n, p, Q_{j2}(n, p)) \\ &= D[p + (1-k_j\beta)v(I_pM_j - 1) - F_i] \\ &\quad - \sqrt{(1-k_j\beta)v(r+I_p)} \\ &\quad \times \sqrt{D^2M_j^2[(1-k_j\beta)vI_p - pI_e] + \frac{2D(S+nh)}{n}}. \quad (18) \end{aligned}$$

For convenience, we let

$$\Delta_j \equiv \frac{nDM_j^2}{2}[(1-k_j\beta)vr + pI_e], j = 1, 2 \quad (19)$$

Because  $M_2 > M_1 \geq 0$ ,  $k_1 = 1$  and  $k_2 = 0$ , we have  $\Delta_2 > \Delta_1$ . Furthermore, let  $Q^{(n)}$  denote the optimal order quantity for given  $n$  and  $p$ , then we obtain the following result.

**Theorem 1.** For any given  $n$  and  $p$ ,

- (a) when  $S + nh \updownarrow \Delta_1$ , if  $\max\{TP_{11i}(n, p), TP_{21i}(n, p)\} = TP_{11i}(n, p)$ , then the optimal payment time is  $M_1$  and  $Q^{(n)} = Q_{11}(n, p)$ ; otherwise, the optimal payment time is  $M_2$  and  $Q^{(n)} = Q_{21}(n, p)$ .
- (b) when  $\Delta_1 \leq S + nh \updownarrow \Delta_2$ , if  $\max\{TP_{12i}(n, p), TP_{22i}(n, p)\} = TP_{12i}(n, p)$ , then the optimal payment time is  $M_1$  and  $Q^{(n)} = Q_{12}(n, p)$ ; otherwise, the optimal payment time is  $M_2$  and  $Q^{(n)} = Q_{22}(n, p)$ .
- (c) when  $\Delta_2 \leq S + nh$ , if  $\max\{TP_{12i}(n, p), TP_{22i}(n, p)\} = TP_{12i}(n, p)$ , then the optimal payment time is  $M_1$  and  $Q^{(n)} = Q_{12}(n, p)$ ; otherwise, the optimal payment time is  $M_2$  and  $Q^{(n)} = Q_{22}(n, p)$ .

**Proof.** It immediately follows from (13), (16) and (19).

**Determination of the retailer's optimal retail price for given  $n$**

For fixed  $n$ , to find the optimal solution of  $p$ , motivated by (13), (16) and (19), we let

$$f_j(p) = \Delta_j = \frac{nDM_j^2}{2}[(1-k_j\beta)vr + pI_e] = \frac{nap^{-\delta}M_j^2}{2}[(1-k_j\beta)vr + pI_e], j = 1, 2. \quad (20)$$

Because of

$$\frac{df_j(p)}{dp} = -\frac{nap^{-\delta-1}M_j^2}{2}[(\delta-1)pI_e + (1-k_j\beta)\delta vr] < 0,$$

$f_j(p)$  is a strictly decreasing function of  $p$ . Furthermore, because  $f_2(p) > f_1(p)$ , for  $p \in (0, \infty)$ ,  $\lim_{p \rightarrow 0} f_j(p) = \infty$  and  $\lim_{p \rightarrow \infty} f_j(p) = 0$ , therefore, for fixed  $n$ ,

we can find a unique value  $p_{j0}$  such that  $f_j(p_{j0}) = S + nh$ , that is

$$S + nh = \frac{nap_{j0}^{-\delta}M_j^2}{2}[(1-k_j\beta)vr + p_{j0}I_e]. \quad (21)$$

Thus, (13) and (16) reduce to

$$\text{if and only if } p \leq p_{j0}, \text{ then } Q_{j1}(n, p) \leq nap^{-\delta}M_j, \quad (22)$$

and

$$\text{if and only if } p \geq p_{j0}, \text{ then } Q_{j2}(n, p) \geq nap^{-\delta}M_j, \quad (23)$$

respectively, where  $p_{j0}$  is the value that satisfies (21).

Consequently, from (22) and (23), our problem in (3) becomes to find the optimal value of  $p$  which maximizes the following total profit per unit time when  $n$  is fixed,

$$TP_{ji}(n, p) \equiv TP_{ji}(n, p, Q^{(n)}) = \begin{cases} TP_{j1i}(n, p), & \text{if } p \leq p_{j0} \\ TP_{j2i}(n, p), & \text{if } p \geq p_{j0} \end{cases}, j = 1, 2, i = 1, 2, \dots, m, \quad (24)$$

where  $TP_{j1i}(n, p)$  and  $TP_{j2i}(n, p)$  are given as in (14) and (18), respectively.

For fixed  $n$ , the optimal value of  $p$  which maximizes  $TP_{jwi}(n, p)$ ,  $j = 1, 2$ ,  $w = 1, 2$ , and  $i = 1, 2, \dots, m$ , can be determined by solving the first order necessary condition,  $\partial TP_{j1i}(n, p) / \partial p = 0$  and  $\partial TP_{j2i}(n, p) / \partial p = 0$ . And examining the second order sufficient condition for concavity, namely  $\partial^2 TP_{j1i}(n, p) / \partial p^2 < 0$  and  $\partial^2 TP_{j2i}(n, p) / \partial p^2 < 0$ .

Summarizing the above arguments, we establish the following algorithm to obtain the optimal solution  $(n^*, p^*, Q^*)$ .

**Algorithm 1:**

Step 0. Set  $n = 0$  and  $TP(n, p^{(n)}, Q^{(n)}) = 0$ .

Step 1. Set  $n = n + 1$ .

Step 2. For  $j = 1, 2$ ,

(2-1) Determine  $p_{j0}$  by solving Eq. (21).

(2-2) If there exists  $p_{j1}$  which satisfy  $p_{j1} \leq p_{j0}$ ,

$\partial TP_{j1}(n, p) / \partial p = 0$  and  $\partial^2 TP_{j1}(n, p) / \partial p^2 < 0$ , then we determine  $Q_{j1}(n, p_{j1})$  by Eq. (12) and perform steps (i)



to (iii). Otherwise, set  $TP_{j1}(n, p_{j1}^{(n)}, Q_{j1}^{(n)}) = 0$ .

(i) if  $q_\varepsilon \leq Q_{j1}(n, p_{j1})/n < q_{\varepsilon+1}$ , where  $0 \leq \varepsilon \leq m$ , then calculate  $TP_{j1\varepsilon}(n, p_{j1}, Q_{j1}(n, p_{j1}))$  using Eq. (14).

(ii) for  $i = \varepsilon + 1, \varepsilon + 2, \dots, m$ , let  $Q_{j1}(n, p_{j1})/n = q_i$ , and calculate  $TP_{j1i}(n, p_{j1}, Q_{j1}(n, p_{j1}))$  using Eq. (14).

(iii) find  $\max_{i=\varepsilon, \varepsilon+1, \dots, m} \{TP_{j1i}(n, p_{j1}, Q_{j1}(n, p_{j1}))\}$  and

$$\text{set } TP_{j1}(n, p_{j1}^{(n)}, Q_{j1}^{(n)}) \\ \equiv \max_{i=\varepsilon, \varepsilon+1, \dots, m} \{TP_{j1i}(n, p_{j1}, Q_{j1}(n, p_{j1}))\}.$$

(2-3) If there exists  $p_{j2}$  which satisfy  $p_{j2} \geq p_{j0}$ ,  $\partial TP_{j2}(n, p)/\partial p = 0$  and  $\partial^2 TP_{j2}(n, p)/\partial p^2 < 0$ , then we determine  $Q_{j2}(n, p_{j2})$  by Eq. (15) and perform steps

(i) to (iii). Otherwise, set  $TP_{j2}(n, p_{j2}^{(n)}, Q_{j2}^{(n)}) = 0$ .

(i) if  $q_{\varepsilon'} \leq Q_{j2}(n, p_{j2})/n < q_{\varepsilon'+1}$ , where  $0 \leq \varepsilon' \leq m$ , then calculate  $TP_{j2\varepsilon'}(n, p_{j2}, Q_{j2}(n, p_{j2}))$  using Eq. (18).

(ii) for  $i = \varepsilon' + 1, \varepsilon' + 2, \dots, m$ , let  $Q_{j2}(n, p_{j2})/n = q_i$ , and calculate  $TP_{j2i}(n, p_{j2}, Q_{j2}(n, p_{j2}))$  using Eq. (18).

(iii) find  $\max_{i=\varepsilon', \varepsilon'+1, \dots, m} \{TP_{j2i}(n, p_{j2}, Q_{j2}(n, p_{j2}))\}$  and

$$\text{set } TP_{j2}(n, p_{j2}^{(n)}, Q_{j2}^{(n)}) \\ \equiv \max_{i=\varepsilon', \varepsilon'+1, \dots, m} \{TP_{j2i}(n, p_{j2}, Q_{j2}(n, p_{j2}))\}.$$

Step 3. Set  $TP(n, p^{(n)}, Q^{(n)}) = \max_{j=1,2} \{TP_{j1}(n, p_{j1}^{(n)}, Q_{j1}^{(n)}), TP_{j2}(n, p_{j2}^{(n)}, Q_{j2}^{(n)})\}$ , then  $(p^{(n)}, Q^{(n)})$  is the optimal solution for given  $n$ .

Step 4. If  $TP(n, p^{(n)}, Q^{(n)}) \geq TP(n-1, p^{(n-1)}, Q^{(n-1)})$ , then go to Step 1. Otherwise, go to Step 5.

Step 5. Set  $TP(n^*, p^*, Q^*) = TP(n-1, p^{(n-1)}, Q^{(n-1)})$ , then  $(n^*, p^*, Q^*)$  is the optimal solution.

## 5. Numerical examples

**Example 1.** An inventory system with the following data is considered:  $a = 10^5$ ,  $\delta = 1.5$ ,  $v = \$10/\text{unit}$ ,  $r = 0.1$ ,  $S = \$500/\text{order}$ ,  $I_p = 0.15$   $\$/\$/\text{year}$  and  $I_e = 0.1$   $\$/\$/\text{year}$ . In addition, a credit term "1/10 net 30" (i.e.,  $M_1 = 10$  days,  $M_2 = 30$  days and  $\beta = 1\%$ ) is offered by the supplier. The fixed transportation cost  $h = \$1500$

/delivery and the freight rate schedule is offered as follows:

$i$	quantity/shipment		$F_i$
1	0	€ 3	\$5.0
		75	0
2	3	€ 8	\$3.3
	75	15	0
3	8	€	\$1.0
	15		0

Applying the Algorithm presented in above, the global maximum  $TP(n^*, p^*, Q^*)$  is \$ 9951.40 where  $Q^* = 5717$  units and  $n^* = 7$ . This order quantity is broken into 7 shipments with 816.71 units per shipment. Hence, the freight rate is \$1. The optimal unit retail price is  $p^* = \$38.39$  with corresponding annual demand  $D^* = 420$  units. The replenishment cycle is  $T = Q^*/(nD^*) = 1.94$  year  $\approx 709$  days and the optimal policy is the retailer makes the payment within 10 days and takes the advantage of 1% discount.

**Example 2.** To analyze the effects of credit terms on performance, using the same data in Example 1, we obtain the computational results for various values of  $M_1$  and  $M_2$  as shown in Table 1.

Table 1 shows if the supplier sets the payment due date at 30 days (i.e.,  $M_2 = 30$ ), then offering a 1% discount can drive the retailer to pay early. For  $M_2 = 30$ , increasing the value of  $M_1$  will decrease the value of the retail price which result in a increase in the values of demand rate, the optimal order quantity and the annual total profit. It is interesting to find that while the payment due date at 60 days (i.e.,  $M_2 = 60$ ), then offering a 1% discount not always drive the retailer to pay early.

While  $M_1 = 0$ , which means to take the advantages of 1% discount the retailer must pay as soon as receiving delivery, the retailer skip the trade discount and delay paying the supplier until the full payment is due as the payment due date at 60 days or more. If the supplier extends his/her credit terms to "1/20, net 60", that is, a 1% discount is being offered if the payment is made within 20 days of the items receive, will drive the retailer to pay early.

As the supplier considers extending the due date to 90 days, the retailer's profit will be maximized as the retailer pays at the end of the net period. This indicates that as the supplier sets the due date at 90 days after delivery, then offering a 1% discount will not help to

speed up his/her cash inflows. According to the results, before adopting a two-part trade credit strategy, the supplier should exam the credit terms very carefully to ensure its effectiveness.

**Table 1. Performances for various credit terms**

$\lambda$	$\lambda_{mal}$	$p^*$	$Q^*$	$D^*$	$T$	$TP^*$
1	0	38.	57	41	7	993
0	0	48	08	9	10	9.63
0	60	38.	32	42	7	994
0	90	33	82	1	11	4.87
0	90	37.	32	42	6	999
0	90	95	71	8	98	7.30
0	10	38.	57	42	7	995
0	10	39	17	0	09	1.40
0	10	38.	57	42	7	995
0	10	39	17	0	09	1.40
0	90	37.	32	42	6	999
0	90	95	71	8	98	7.30
0	20	38.	65	42	7	996
0	20	27	25	2	05	8.61
0	20	38.	65	42	7	996
0	20	27	25	2	05	8.61
0	90	37.	32	42	6	999
0	90	95	71	8	98	7.30

## 6. Conclusion

In this paper, we developed an EOQ model in a shipping-quantity-dependent freight cost and “two-part” trade credit environments. Furthermore, conceptual contributions include the development of a streamlined calculation of the EOQ to determine the optimal solution under various conditions. Finally, a numerical example is given to illustrate the theoretical results and obtain some managerial insights. We believe that our work will provide a basic foundation for the further study of this kind of important inventory models with trade credits.

Some clear conclusions emerge from the numerical study. It is found as the supplier sets the due date after delivery too long, then offering a 1% discount may not help to speed up his/her cash inflows. Therefore, before adopting a two-part trade credit strategy, the supplier should exam the credit terms very carefully to ensure its effectiveness.

The proposed model can be extended in several ways. For instance, we may extend the model for deteriorating items. Also, we could consider the demand as a function of selling price as well as time.

Finally, we could generalize the model to allow for shortages, quantity discounts, inflation rates, and others.

## Acknowledgements

This research was supported by the National Science Council of the Republic of China under Grant NSC 99-2410-H-130 -030.

## References

- [1] Mateut, S., Bougheas, S. and Mizen, P., “Trade credit, bank lending and monetary policy transmission”, *European Economic Review*, 2006, 50(3), pp. 603-629.
- [2] Guariglia, A. and Mateut, S., “Credit channel, trade credit channel, and inventory investment: evidence from a panel of UK firms”, *Journal of Banking and Finance*, 2006, 30(10), pp. 2835-2856.
- [3] Ge, Y. and Qiu, J., “Financial development, bank discrimination and trade credit”, *Journal of Banking and Finance*, 2007, 31(2), pp. 513-530.
- [4] Petersen, M. A. and Rajan, R. G., “Trade credit: theories and evidence”, *The Review of Financial Studies*, 1997, 10, pp. 661-691.
- [5] Goyal, S.K., “Economic order quantity under conditions of permissible delay in payments”, *Journal of the Operational Research Society*, 1985, 36, pp. 335-338.
- [6] Ouyang, L.Y., Chang, C.T. and Teng, J.T., “An EOQ model for deteriorating items under trade credit”, *Journal of the Operational Research Society*, 2005a, 56, pp. 719-726.
- [7] Chung, K.J. and Liao, J.J., “The optimal ordering policy in a DCF analysis for deteriorating items when trade credit depends on the order quantity”, *International Journal of Production Economics*, 2006, 100, pp. 116-130.
- [8] Teng, J.T., “Optimal ordering policies for a retailer who offers distinct trade credits to its good and bad credit customers”, *International Journal of Production Economics*, 2009, 119, pp. 415-423.
- [9] Tripathi, R.P., Misra, S.S., and Shukla, H.S., “A cash flow oriented EOQ model under permissible delay

in payments”*International Journal of Engineering, Science and Technology*, 2010, 2(11), pp. 123-131.

[10] Khanra, S., Ghosh, S.K., and Chaudhuri, K.S., “An EOQ model for a deteriorating item with time dependent quadratic demand under permissible delay in payment”*Applied Mathematics and Computation*, 2011, 218(1), pp. 1-9.

[11] Musa, A. and Sani, B., “Inventory ordering policies of delayed deteriorating items under permissible delay in payments”*International Journal of Production Economics*, 2012, 136, pp. 75-83.

[12] Ouyang, L.Y., Teng, J.T., Chuang, K.W., and Chuang, B.R., “Optimal inventory policy with noninstantaneous receipt under trade credit”*International Journal of Production Economics*, 2005b, 98, pp. 290-300.

[13] Huang, Y.F. and Goyal, S.K., “Retailer’s replenishment policy under supplier credit linked to payment time”*Information and Management Sciences*, 2007, 18(1), pp. 49-62.

[14] Goyal, S.K., Teng, J.T., and Chang, C.T., “Optimal ordering policies when the supplier provides a progressive interest scheme”*European Journal of Operational Research*, 2007, 179(2), pp. 404-413.

[15] Sana, S.S. and Chaudhuri, K.S., “A deterministic EOQ model with delays in payments and price-discount offers”*European Journal of Operational Research*, 2008, 18(2), pp. 509-533.

[16] Yang, C.T., “The optimal order and payment policies for deteriorating items in discount cash flows analysis under the alternatives of conditionally permissible delay in payments and cash discount”*Top*, 2010, 18(2), pp. 429-443.

[17] Ertogral, K., Darwish, M., Ben-Daya, M., “Production and shipment lot sizing in a vendor-retailer supply chain with transportation cost”*European Journal of Operational Research*, 2007, 176(3), pp. 1592-606.

[18] Tersine, R.J. and Toelle, R.A., “Lot size determination with quantity discounts”*Production and Inventory Management*, 1985, 27(4), pp. 134-137.

[19] Lee, C.Y., “The economic order quantity for freight discount costs”*IIE Transactions*, 1986, 18(3), pp. 318-320.

[20] Hwang, H., Moon, D.H. and Shinn S.W., “An EOQ model with quantity discounts for both purchasing price and freight cost”*Computers&Operations Research*, 1990, 17 (1), pp. 73-78.

[21] Tersine, R.J. and Barman, S., “Optimal lot sizes for unit and shipping discount situations”*IIE Transactions*, 1994, 26(2), pp. 97-101.

[22] Russell, R.M. and Krajewski, L., “Optimal purchase and transportation cost lot sizing on a single item”*Decision Science*, 1991, 22, pp. 940-952.

[23] Swenseth, S.R. and Godfrey, M.R., “Incorporating transportation costs into inventory replenishment decisions”*International Journal of Production Economics*, 2002, 77 (2), pp. 113-130.

[24] Abad, P.L. and Aggarwal, V., “Incorporating transport cost in the lot size and pricing decisions with downward sloping demand”*International Journal of Production Economics*, 2005, 95, pp. 297-305.

[25] Rieksts, B.Q. and Ventura, J.A., “Optimal inventory policies with two modes of freight transportation”*European Journal of Operational Research*, 2008, 186(2), pp. 576-585.

[26] Viau, M.A., Trepanier, M., and Baptiste, P., “Integration of inventory and transportation decisions in decentralized supply chains”*International Journal of Logistics Systems and Management*, 2009, 5(3-4), pp. 249-272.

[27] Rieksts, B.Q. and Ventura, J.A., “Two-stage inventory models with a bi-model transportation cost”*Computers&Operations Research*, 2010, 37, pp. 20-31.

[28] Choudhary, D. and Shankar, R., “Modeling and analysis of single item multi-period procurement lot-sizing problem considering rejections and late deliveries”*Computers&Industrial Engineering*, 2011, 61(4), pp. 1318-1323.

[29] Tsao, Y.C. and Lu, J.C., “A supply chain network design considering transportation cost

discounts”,*Transportation Research Part E: Logistics and Transportation Review*, 2012, 48(2), pp. 401-404.

[30] Shinn, S.W., Hwang, H. and Park, S.S., “Joint price and lot size determination under conditions of permissible delay in payments and quantity discounts for freight cost”,*European Journal of Operational Research*, 1996, 91(3), pp. 528-542.

[31] Sheen, G.J. and Tsao, Y.C., “Channel coordination, trade credit and quantity discounts for freight cost”,*Transportation Research Part E: Logistics and Transportation Review*, 2007, 43(2), pp. 112-128

[32] Ouyang, L.Y., Ho, C.H. and Su, C.H., “Optimal strategy for an integrated system with variable production rate when the freight rate and trade credit are both linked to the order quantity”,*International Journal of Production Economics*, 2008, 115(1), pp. 151-162.

[33] Tsao, Y.C. and Sheen, G.J., “A multi-item supply chain with credit periods and weight freight cost discounts”, *International Journal of Production Economics*, 2012, 135(1), pp. 106-115.

[34] Chung, K.J., “The integrated inventory model with the transportation cost and two-level trade credit in supply chain management”,*Computers & Mathematics with Applications*, 2012, 64(6), pp. 2011-2033.

# An Exploration of the Travel Agents' Attributes Classification: The Perception of NTO Abroad Offices

Chin-Tsai, Lin<sup>1\*</sup>; Jung-Ho, Lu<sup>1</sup>; Yeok-How, Goay<sup>1,2</sup>; Hwa-Rong, Shen<sup>1</sup>; Yi-Hsien, Wang<sup>3</sup>  
Department of Business Administration, Ming Chuan University, Taipei, Taiwan<sup>1</sup>  
Department of Travel Management, Taipei College of Maritime Technology, New Taipei City, Taiwan.<sup>2</sup>  
Department of Banking and Finance, Chinese Culture University, Taipei City, Taiwan.<sup>3</sup>  
[ctlin@mail.mcu.edu.tw](mailto:ctlin@mail.mcu.edu.tw), [lulu2008@gmail.com](mailto:lulu2008@gmail.com), [ikanpeyu@yahoo.com.tw](mailto:ikanpeyu@yahoo.com.tw), [Hwa\\_rong@yahoo.com.tw](mailto:Hwa_rong@yahoo.com.tw),  
[Holland@mail2000.com.tw](mailto:Holland@mail2000.com.tw)

## Abstract

The national tourism organization (NTO) abroad office must understand the interaction behavior (IB) of travel agents in respectively market, because it could help NTO abroad offices effectively and efficiently position market and competitive strategies to entice their core market. NTO abroad offices can use critical IB to discriminate significantly among derived market segments. The paper accordingly presents and develops a model which attempts to articulate and classify travel agent IB with NTO abroad office by a brainstorming group discussion, followed by a questionnaire to map the travel agent in the quadrant to understand the phenomenon of the travel agent market.

**Keywords :** national tourism organization, travel agent, travel market segmentation, involvement, confidence, interaction behaviours

## 1. Introduction

Increased competitiveness of the international tourism industry, combined with the proliferation of developing and emerging countries, such as Mongolia [1] and Myanmar [2], have led most countries to compete through their respective national tourism organization (NTO), to convince and tackle the overseas tourism market. Therefore, the NTO has played a vital role as the "critical arm" to develop, maintain, and improve tourism matters, particularly for developing and emerging countries [3] [4].

Today, NTO abroad offices increasingly seek to understand travel agent behaviors attributes where they can create strategic and competitive activities in the current turbulent and globalized market. For NTO abroad offices, interaction behavior (IB) with travel agents serves as a vital "weapon" to create market opportunities and to seize their critical market benefit and proficiency [4]. Travel agent IB may help NTO abroad offices effectively and efficiently position

market and competitive strategies to entice their core market. NTO abroad offices can use critical IB to discriminate significantly among derived market segments. Therefore, managing and strengthen the need to interact with a travel agent have become the top priority for NTO, particularly their abroad offices in the respectively countries. Against this background of rapid change and increased competition, this paper focus on explores travel agent IB with NTO abroad offices and the propensity to interact with NTO abroad offices that influences NTO abroad office marketing and promotional activities in the travel market.

Consequently, it is necessary to practically and theoretically understand travel agent IB of NTO abroad offices. However, building a strong interaction with travel agents requires understanding travel agent IB and insights. This study explores the usefulness of travel agent IB-based features as a relevant competitive instrument in the travel agent market, particularly for NTO abroad offices. This study also uses the IB-based scheme to obtain diverse market mapping to incorporate differential tendencies and features.

## 2. Briefing of Tourism Market Intermediates and Travel Agents

### 2.1 Tourism Market Intermediates

Tourism market intermediates have become one of the most critical and significant elements influencing all other aspects of the competitive mix for NTO abroad offices, particularly in the international tourism market, such as travel agents and journalists [4]. The main role of intermediates in tourism market is to provide information and exchange market intelligence, information and market dynamics with NTO abroad offices as well as influence and convince consumer and counterpart decision-making or demand, particularly travel agents [5] [6].

From the aspect of NTO abroad offices, travel agents play an important role as "gatekeepers" [7] or

information providers [8] in gathering and analyzing, sieve and appraisals to provide convenient points of market intelligence and travel trade information, including market consumption trends, travel market variations, and assessing competitor activities, as well as serve as a linker between NTO abroad office and market [4]. Meantime, cooperating with a travel agent to create and manipulate tourist access, particularly in the meeting, incentive, convention and exhibition market, is a principal method to manage demand for high competitiveness of NTO abroad offices. This includes co-organizing promotional activities with other industries and associations to enhance the image and reputation of a respective country. Hence, travel agents are not only primary intermediates, but also as marketing mix elements of NTO abroad office.

Currently, most of the market intermediaries play the “customer” role in business and marketing [9] [10] [11] [12] [13], including the travel agent as an intermediate in the tourism industry. For NTO abroad office, all types of travel agents are vital “customers” , and developing, managing, as well as understanding these customer efficiency and effectiveness roles as a strong source of competitiveness to tackle the market. In this study, we consider the travel agent as the vital customer for NTO abroad offices.

## 2.2 Travel Agents

In the tourism industry, the travel agent represents a core element and predominant influence in the tourism marketing system, and is a critical interface, information broker, and unique niche in the tourism distribution system without any stock, except for knowledge and information [14] [7] [15]. Meantime, because of customer know-how, skillsets and competence, customers have become new sources of competence, innovators, and advocates [12] [16]. The travel agent actively co-constructs interactions with NTO abroad offices and co-creates a unique value for both sides. Therefore, travel agents as customers are valuable and important core resources in increasing competitiveness in NTO abroad offices, and their mutual interaction offers new market opportunities for NTO abroad offices. The travel agent as a customer with the NTO office abroad is crucial in enabling the sharing of information, ideas, and knowledge, and the performance of NTO abroad offices to customers as the main source of competence and knowledge [12].

From the perspective of NTO abroad offices, the travel agent market in respective country is becoming increasingly multilateral and competitive to attract and manage travel agents in a wide range of strategic

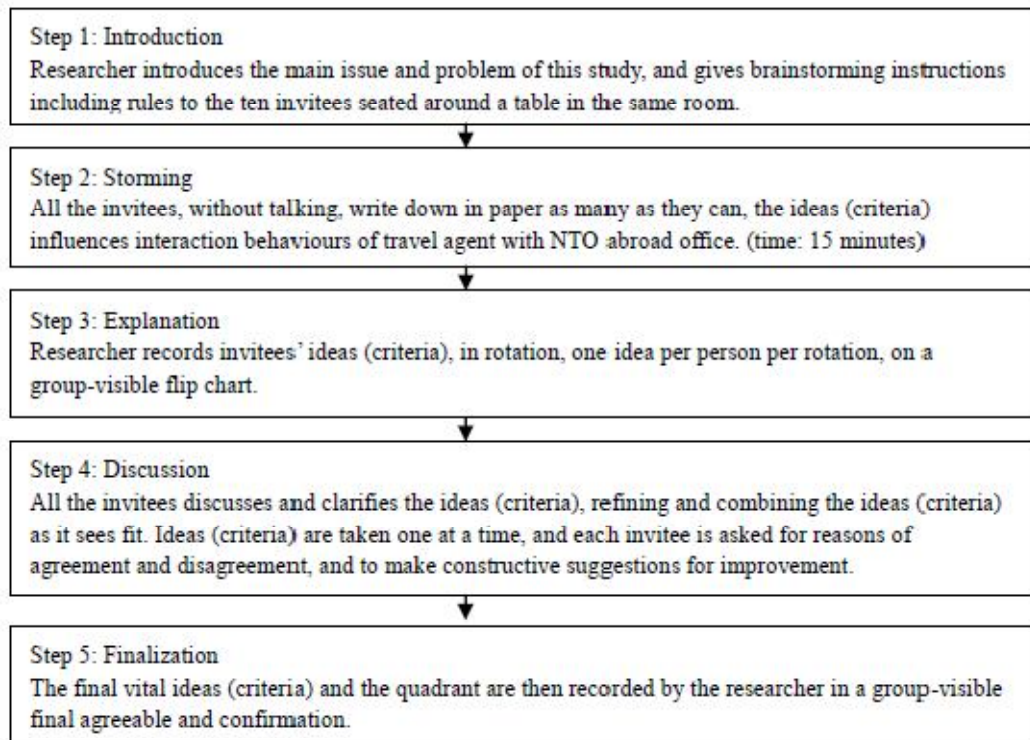
marketing [4]. Travel agents assist NTO abroad offices to improve, share, exchange, and combine experiences and knowledge, and provide alternative or new interpretations of market information or knowledge because overseas offices cannot independently develop or create knowledge requirements and skills or market intelligence efficiency and effectiveness to compete in a capricious environment. NTO abroad offices would have difficulty maintaining long-term benefits and competitive advantages if they only execute the same operational model without interacting with travel agents to improve their performance over their competitors. Therefore, NTO abroad offices should interact with travel agents dynamically to obtain necessary resources to build competitive advantage.

However, in most countries, travel agent segmentation is typically based on the scope of their capital, business activities, and deposits. In Europe and the United States, travel agents are classified into tour operators or wholesalers and retail travel agents, whereas travel agents in Taiwan are categorized into Class General (Consolidated), Class A, and Class B [15] [17]. From the perspective of NTO abroad offices, this type of classification is inadequate and unable to meet the needs of NTO abroad offices [4]. The typical classification segment of travel agents is unfeasible for NTO abroad offices to understand the insights of travel agent IB. In this study, travel agent IB with NTO abroad offices is depicted as an affected condition in which overseas offices evaluate the travel agent classification.

## 3. Methodology

To better understand the travel agent as a customer in the context of travel agent IB with NTO abroad offices, because research in the field of travel agent IB with NTO abroad offices is scant, we developed a matrix for this study based on the “idea type” methodology outlined by [18] [19] and [20] indicated by [21].

In this study, we conducted an exploratory study using a brainstorming discussion to identify the underlying constructs or imperatives that determine travel agent IB with NTO abroad offices as Figure 1. Invitees of the brainstorming discussion comprised 10 respondents, comprising 9 Directors and 1 Deputy Directors from NTO abroad offices in Taiwan, whose experience in the field exceeded 15 years. All of the discussions were taped.



**Figure 1. Brainstorming Discussion Procedure**

#### 4. Findings

The vital critical that were assessed during the brainstorming discussion are described as below and is similar to the study conducted by [21] in the United Kingdom, indicating that involvement as the behavior factor and confidence as the psychological factor are the two essential factors required to construct IB.

##### 4.1 Involvement

In accordance with the brainstorming discussion, this study emphasizes that involvement is based on a shared value and personal needs, values, and interests, and travel agent awareness is important for information, intelligence, and resources from NTO abroad offices, and their relatedness includes a willingness for future collaboration and cooperation to create new opportunities.

Travel agents increasingly act as advocates of the value-creation process for NTO abroad offices, including crisis management and emergency cases. NTO abroad offices can use travel agent involvement to save promotional activity costs. The travel agent also

acts as a promoter and advisor for NTO abroad offices in certain markets such as for frequenters of casinos and the luxury market. The likelihood and motivation of receiving and providing quantity and quality market information and intelligence are considered to be one of the degrees of involvement in the interaction between travel agents and NTO abroad offices. The increasing involvements between travel agents and NTO abroad offices have changed the rules for gaining competitive advantage. This implies that, in a hypercompetitive market, travel agents as customers have increasingly become a valuable and competitive resource for NTO abroad offices.

##### 4.2 Confidence

Professional knowledge, instant market information, know-how and skillsets of NTO abroad offices remain critical for travel agents because they lower the search and reduce travel agent costs, building confidence with NTO abroad offices to assist in strengthening travel agent market reputation and increasing communication quality. Confidence also



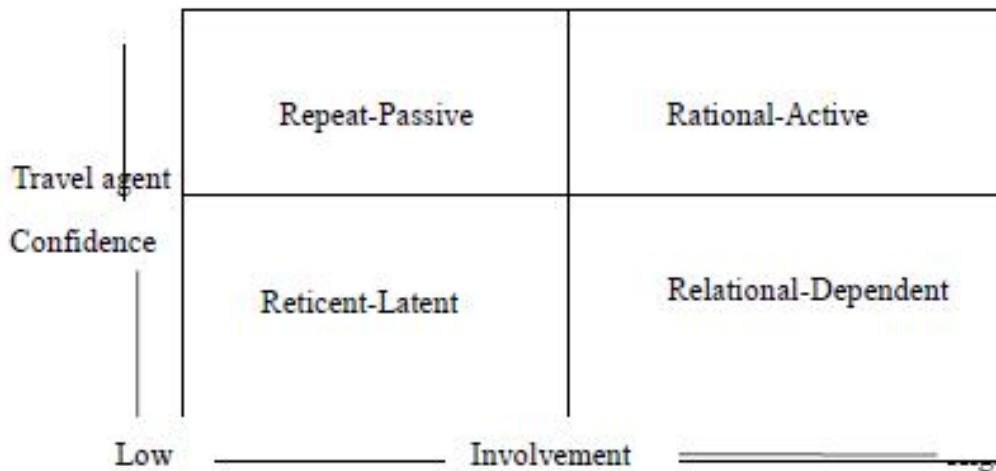
reduces social and communication complexities and uncertainties related to future cooperation and joint activities, particularly new product development. Furthermore, in an environment of proliferating information, travel agents consider the diverse and heterogeneous expertise of NTO abroad offices to be able to guarantee their confidence and loyalty. Effective confidence leads to the travel agent to believe

that it is not in the best interest of the interaction to defect, including sensitive issues and information. Travel agent confidence remains a substantial psychological element for NTO abroad offices to understand the characteristics and phenomenon of travel agent operation in the travel market.

### 4.3 Segmentation

Based on segmentation principles, by positioning these vital factors on a simple continuum running from low to high, it is possible to construct a two dimensional matrix of travel agent IB, which provides insights into the possible range of the IB model [21] [22].

To relate the concept of travel agent IB with NTO abroad offices into the travel market, it is necessary to explore the fundamental characteristics of the travel market. This is important because NTO abroad offices could refer to the difference segment of travel agent IB and adopt a different approach and strategy to increase their competitiveness.



**Figure 1 Travel Agent Interaction Behavior Matrix**

## Conclusion

According to the study findings, travel agent segmentation by involvement and confidence of travel agent IB with NTO abroad offices is an effective approach for NTO abroad offices decision makers. Based on the IB level, NTO abroad offices can be considered a primary and secondary market resource. Primary resources show a high degree of consensus and implication with NTO abroad offices. The travel agent may discover other underlying issues and engagement existing between matters such as apportion risk, access problems, improving convenience or inertia, and strengthening interrelations with travel agent to create the market opportunity and trend. For secondary resources, to launch certain marketing campaign and activities, quadrant features could be used by NTO abroad offices to tackle specific preferences. This would improve marketing and competitive strategy effectiveness for NTO abroad offices, particularly because of economic uncertainties and tight budgets.

## References

- [1] W.T.O. "Mongolia looks to tourism to diversify its economy", Retrieved from <http://media.unwto.org/en/news/2012-08-07/mongolia-looks-tourism-diversify-its-economy>. 07 August, 2012, accessed 10 October 2012.
- [2] W.T.O. "Myanmar set to rejoin UNWTO", Retrieved from <http://media.unwto.org/en/press-release/2012-05-11/myanmar-set-rejoin-unwto>. 11 May, 2012, accessed 10 October 2012.
- [3] T. Baum, "The development and implementation of national tourism policies", *Tourism Management*, 15(3), 1994, pp.185-192.
- [4] C.T. Lin, and Y.H. Goay, "Measuring National Tourism Organization Abroad Offices Competitiveness", *International Journal of Tourism Research*, 2013, (under revised).
- [5] W.T.O. *Distribution channels*. W.T.O., Spain: Madrid, 1975
- [6] D. Buhalis, "Relationships in the distribution channel of tourism: Conflicts between hoteliers and tour operators in the Mediterranean region", *International Journal of Hospitality & Tourism Administration*, 1(1), 2000, pp. 113-139.
- [7] B. McKercher, T. Packer, M.K. Yau, and P. Lam, "Travel agent as facilitators or inhibitors of travel: Perception High people with disabilities", *Tourism Management*, 24(4), 2003, pp. 465-474.
- [8] C. Jeong, and S. Holland, "Destination image saturation", *Journal of Travel & Tourism Marketing*, 29(6), 2012, pp. 501-519.
- [9] K.P. Gwinner, D.D. Gremler, and M.J. Bitner, M. J. "Relational benefits in services industries: The customer's perspective", *Journal of the Academy of Marketing Science*, 26 (2), 1998, pp. 101-114.
- [10] F.E.Jr. Webster, "Understanding the relationships among brands, consumers, and resellers. *Journal of Academy of Marketing Science*, 28(1), 2000, pp.17-23.
- [11] D. Jarratt, "Conceptualizing a relationship management capability", *Marketing Theory*, 4(4), 2004, pp. 287-309.
- [12] A. Graf, "Changing roles of customer: consequences for HRM", *International Journal of Service Industry Management*, 18(5), 2007, pp. 491-590.
- [13] P.C. Verhoef, W.J. Reinartz, and M. Krafft, "Customer engagement as a new perspective in customer management", *Journal of Service Research*, 13(3), 2010, pp. 247-252.
- [14] D.B. Klenosky, and R.E. Gitelson, "Travel agents destination recommendations", *Annals of Tourism Research*, 25(3), 1998, pp.661-674.
- [15] S.H. Tsaur, C.Y. Yung, and J.H. Lin, "The relational behavior between wholesaler and retailer travel agents: Evidence from Taiwan", *Journal of Hospitality & Tourism Research*, 30(3), 2006, pp. 333-353.
- [16] O. Chervonnaya, "Customer role and skill trajectories in services", *International Journal of Service Industry Management*, 14(3), 2003, pp.347-363.
- [17] M.M. Bennet, and C.W.K. Lai, "The impact of the internet on travel agencies in Taiwan", *Tourism and Hospitality Research*, 6(1), 2005, pp. 8-23.
- [18] M. Weber, *The methodology of the social sciences*. Free Press, New York, 1949.

[19] F.R. Dwyer, P.H. Schurr, and S. Oh, "Developing buyer-seller relationships", *Journal of Marketing*, 51(2), 1987, pp. 11-27.

[20] J.W. Thibaut, and H.H. Kelly, *The social psychology of groups*, John Wiley, Oxford, England, 1959.

[21] A. Beckett, P. Hower, and B. Howcroft, "An exposition of consumer behavior in the financial services industry", *International Journal of Bank Marketing*, 18(1), 2000, pp. 15-26.

[22] H.J. Chen, P.J. Chen, and M.H. Wang, "Application of perception-promotion matrix model—the case of Kaohsiung City", *Journal of Travel & Tourism Marketing*, 29(2), 2012, 163-184.

## The Work Performance of Foreign Caregivers in Taiwan's Human Resource Market

Chie-Bein Chen, Kuochung Chang, Yuan-Du Hsiao, Kuang-Yi Lin, Kuang-Yi Lin and Ho-Chen Lin

Department of International Business, National Dong Hwa University<sup>1</sup>  
No. 1, Sec. 2 Da-hsueh Rd., Shou-feng, Hualien, 974, Taiwan, R. O. C.  
cbchen@mail.ndhu.edu.tw

Department of International Business, National Dong Hwa University<sup>2</sup>  
No. 1, Sec. 2 Da-hsueh Rd., Shou-feng, Hualien, 974, Taiwan, R. O. C.  
kcchang@mail.ndhu.edu.tw

Department of Business Administration, Chungyu Institute of Technology<sup>3</sup>  
No. 40, Yi 7 Rd., Keelung, Taiwan, R. O. C.  
yuduhsiao4471@yahoo.com.tw

Doctoral Program, Department of Business Administration, National Central University<sup>4</sup>  
No.300, Jhongda Rd., Jhongli City, Taoyuan County 320, Taiwan, R.O.C.  
research.go.go@gmail.com

Executive Master Program of Business Administration, National Dong Hwa University<sup>5</sup>  
No.1, Sec. 2, Dasyue Rd., Shoufong Township, Hualien County 974, Taiwan, R.O.C.  
e-mail: monica0450@yahoo.com.tw

### Abstract

*This study focused on foreign caregivers in Taiwan, and used employers' observations and perceptions during foreign caregivers' employment periods to measure their work performance. Questionnaire surveys were conducted with employers as participants based on the relevant key factors that influence foreign caregivers' work performances identified by examining previous studies. The completed questionnaires were analyzed using structural equation modeling (SEM) to assess the correlation level among "personality traits," "demographic variables," "work attitude," "work environment," and "homecare guidance" and influences on "work performance." This information was used to establish a model for evaluating foreign caregiver selection, service environments, and service types. The objective of this study was to develop key factors for enhancing employers' suitable selection of caregivers to promote harmony between employers and employees and increase employer satisfaction. These key factors can also strengthen employers' loyalty to human resource agencies, increase the profitability of human resource agencies, and enhance operational decisions in the human resource industry regarding future selections of suitable personnel. It can also serve as a reference for the general selection of foreign caregivers.*

**Keywords:** *Foreign caregivers, personality traits, work attitude, work environment, homecare guidance, work performance*

### 1. Introduction

In response to elderly homecare issues resulting from low birth rates, the increased elderly population, and the slow development of various social welfare policies, the Council of Labor Affairs of Taiwan has allowed foreign caregivers to work in Taiwan to meet current homecare needs. Foreign caregivers come from countries with differing economies, societies, and cultures. Therefore, referencing relevant research, this study examined the correlation levels of "personality traits," "demographic variables," "work attitude," "work environment," and "homecare guidance" for influencing on "work performance." Using employers' observations and perceptions during the employment period, we can understand foreign caregivers' work performance and provide a reference for the human resource industry regarding future decisions and selections of suitable personnel, as well as a general reference suitable for all foreign caregiver selections. Thus, the objectives and issues of focus for this study were as follows:

To understand the influence that various personality traits and demographic variables have on work attitudes, we used the Big Five personality traits and demographic variables of foreign caregivers as moderating variables, and employed linear regression to examine and analyze caregivers' work attitudes.

(1) To understand the influence that receiving homecare guidance provided by human resource agencies had on foreign caregivers' work

performance, the work attitude, work environment, and homecare guidance of foreign caregivers were employed as moderating variables, and a linear regression was conducted to examine and analyze employers' perspectives on caregivers' work performances.

(2) Based on the frameworks of (1) and (2), a structural equation was employed to examine the relationship between the foreign caregiver work performance framework models developed in this study.

This study investigated employers' perceptions of foreign caregivers' work performances. We also examined the correlations between the personality traits, work attitudes, and work performance of foreign caregivers; the suitability of supply and demand sides; and the relationship between foreign caregivers receiving homecare guidance from human resource agencies and their work attitudes and performance. The information provided in this study can enable the human resource industry and employers of foreign caregivers to understand the various personality traits of each caregiver, and improve work attitudes and performance by examining homecare guidance needs and emphases. The results of this study also provide a reference for the human resource industry and employers for selecting suitable personnel in the future, thereby increasing caregiving abilities. Consequently, the care recipients will receive superior care, and employers will feel less burdened and experience a decline in caregiving pressure. Providing employees with a comfortable work environment results in fewer problems, such as changing employers, deportation, or running away, caused by personnel unsuitability. This reduces social costs and can enable society to achieve a state of harmonious balance.

## 2. Literature review

### (1) Personality traits

For this study, we employed the Big Five personality traits proposed by Costa *et al.*, [8] that comprised five measurement dimensions, namely agreeableness, extraversion, conscientiousness, neuroticism, and openness. Of these five traits, conscientiousness is recognized as the main aspect used to predict work performance. The results of Barrick and Mount [3] indicated that conscientiousness is the most widely applicable personality trait for predicting the work performance of people with various positions. In other words, this personality trait possesses a consistent relationship with work performance in all fields.

### (2) Work attitude

Robbins [19] stated that in the field of organizational behavior, three factors related to work attitude are frequently examined, namely job satisfaction, job involvement, and organizational commitment. For this study, we referenced the organizational commitment model proposed by Lee *et al.*, [17], which included scales for three subdimensions: value, effort, and retention commitment.

### (3) Work performance

Based on the research framework employed by Campbell [6], Borman and Motowidlo [5] divided performance into two categories, that is, task performance and contextual performance. The methods for measuring performance are self-evaluation or evaluation by others. According to the findings reported by Meyer [19] and Anderson [1], employees frequently overestimate their work performance, generating an overly tolerant or indulgent evaluation trend [16]. Therefore, in this study, we invited employers of foreign caregivers to complete performance assessments.

### (4) Work environment

The theory of work adjustment proposed by Hershenson [14] is frequently employed and focuses on the interaction between an individual and the environment. Therefore, excellent work adjustment by foreign caregivers is closely related to the surrounding work environment. In addition, a suitable work environment is crucial to work adjustment and a factor that influences work performance.

### (5) Homecare guidance

According to investigations of care requirements for individual homecare cases, the most vital care requirement regarding foreign caregivers' knowledge and health education is the attainment of care information and skills [7]. The pre-employment training courses that foreign caregivers receive at labor training centers in their home countries before arriving in Taiwan focus primarily on adapting to life abroad. Courses that cultivate professional work skills, care knowledge, problem solving abilities, and crisis management skills are insufficient. Furthermore, the majority of these courses are taught in classes that rely on verbal instruction without response and practice regarding actual techniques. Thus, a disparity remains between foreign caregivers' training and the practical work conditions in Taiwan [15]. In addition, foreign caregivers also experience difficulty obtaining health care information because of the differences in culture, customs, habits, and

language, which subsequently and indirectly influences their quality of care. Therefore, foreign caregivers' care abilities should be continuously evaluated and developed [18].

Related studies have shown that the Big Five personality traits provide a specific and common tool for discussions of cross-cultural personality traits and are not restricted by region or culture. Therefore, the Big Five personality traits can also be adapted to foreign caregivers. Cultural differences and work environment adjustments commonly influence foreign caregivers' work performance, which affects subsequent performance evaluations. Based on our previous discussion and because of various spatial and temporal backgrounds, work characteristics, and research participants, we employed the five primary dimensions of personality traits, work attitudes, work environment, homecare guidance, and work performance to evaluate foreign caregivers' work performance. In this study, we measured the level of influence that foreign caregivers' personality traits, work environment, and homecare guidance had on their work performance and attitude to examine the work performance of foreign caregivers.

### **3. Research methodology**

#### **(1) Research framework**

Language and communication skills, habits and customs, dietary habits, religious beliefs, job perceptions, and caregiving experience are all factors that influence the work and life adjustment of foreign caregivers employed to provide homecare services. Therefore, we used "personality traits" and "demographic variables" as moderating variables to examine caregivers' work attitudes, and used "work environment" and "homecare guidance" as moderating variables to examine influences on foreign caregivers' work attitudes and work performance. In addition, we also discussed relevant questions to identify appropriate solutions and provide recommendations. The research framework adopted for this study is shown in Fig. 1.

#### **(2) Research hypothesis framework**

Based on the research framework (Fig. 1), we used domestic employers' (who are currently employing or have previously hired foreign caregivers) evaluations of foreign caregivers' work performance to examine the correlation between personality traits, demographic variables, work attitude, work environment, and homecare guidance. This study referenced the idea of perception in the technology acceptance model (TAM) proposed by Davis [9] as a foundational concept to examine

employers' use of employment perceptions to evaluate foreign caregivers' work performance. We also conducted relevant investigations of questions regarding various dimensions such as personality traits, demographic variables, work attitude, work environment, and homecare guidance to recommend appropriate solutions. Based on this information, we established a research hypothesis framework, as shown in Fig. 2.

#### **(3) Research hypotheses**

- H1: Employers perceive that foreign caregivers' work attitude positively influences their work performance.
- H2: Employers perceive that foreign caregivers' demographic variables cause different influences for personality traits.
- H3: Employers perceive that foreign caregivers' demographic variables cause different influences for work attitudes.
- H4: Employers perceive that foreign caregivers' personality traits positively influence their work attitudes.
- H5: Employers perceive that foreign caregivers' personality traits positively influence their work performance.
- H6: The work environment provided by employers shows moderating effects for employees' work attitude and work performance.
- H7: Employers perceive that the homecare guidance provided by human resource agencies shows moderating effects for employees' work attitude and work performance.

### **4. Research design**

For this study, we collected information through questionnaires distributed among employers of foreign caregivers. The questionnaire content comprised employers' perception-based measurements of foreign caregivers' personality traits, demographic variables, work attitude, work environment, homecare guidance, and work performance. Human resource agencies provided information of employers who had hired foreign caregivers for sample collection. Subsequently, questionnaires were also distributed to family and friends, classmates, and co-workers who employed foreign caregivers to further collect samples. The questionnaire distribution period was between April 13, 2012, and May 15, 2012. Of the 115 questionnaires retrieved, five were invalid, resulting in a total of 110 valid questionnaires. The questionnaire design was based on the research framework and hypotheses proposed in this study.

Methods such as linear regression, independent samples *t*-test, and one-way analysis of variance (ANOVA) were employed to examine the relative influence or differences between personality traits, demographic variables, work attitude, work

environment, homecare guidance, and work performance variables. In addition, a structural equation was used to verify the relationship between the research framework models of the various variables.

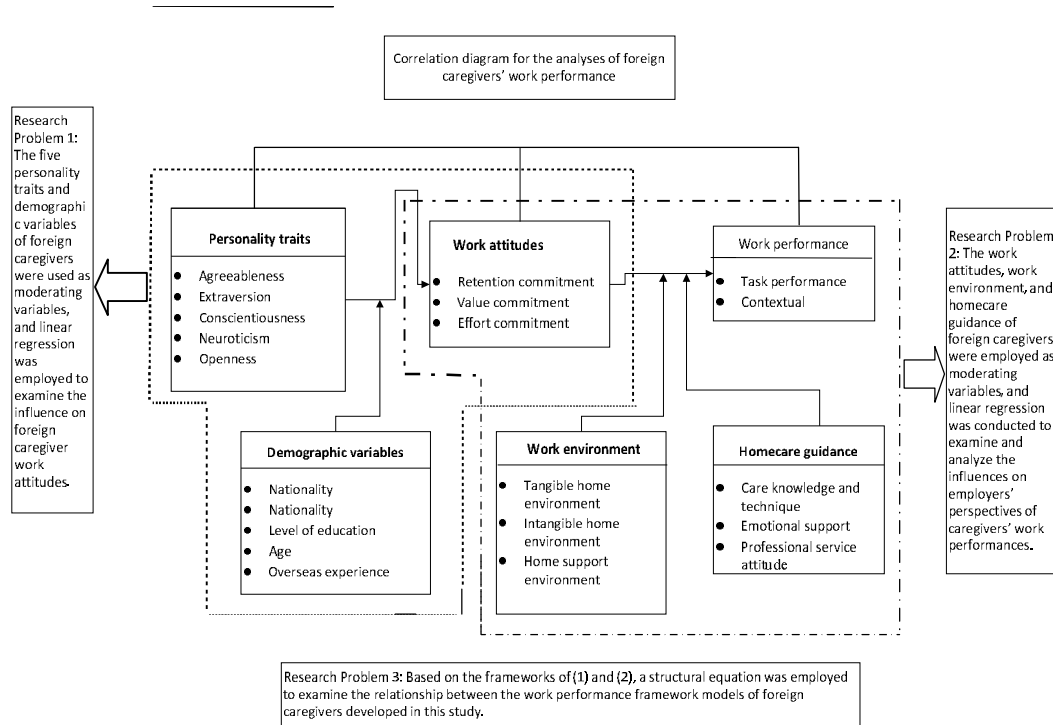


Figure 1. Research framework for employers' perception of foreign caregivers' work performance

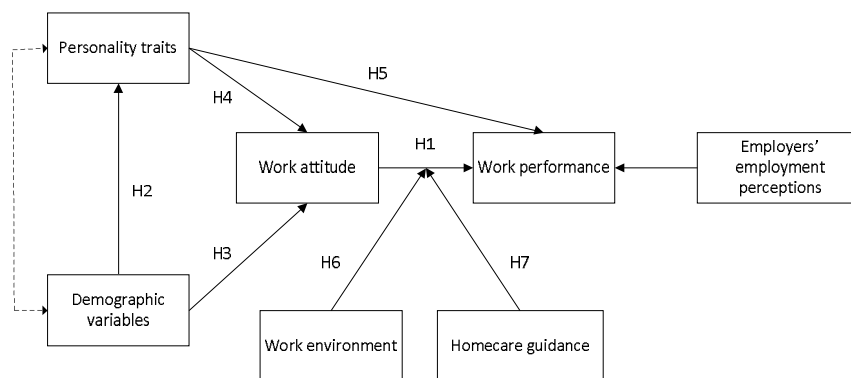


Figure 2. Research hypothesis framework

## 5. Data analysis method

Data acquired from the questionnaire survey conducted in this study were analyzed using various methods including inferential statistics and difference analysis, reliability and validity analysis, factor analysis, correlation analysis, regression analysis, and structural equation modeling (SEM) analysis.

## 6. Statistical analysis

### (1) Independent samples *t*-test analysis

- A. An examination on whether overseas experience resulted in significant differences in personality traits and work attitudes

This study used independent samples *t*-tests to determine whether basic data variables for overseas

experience caused differences in employers' views and perceptions of the agreeableness, extraversion, conscientiousness, neuroticism, and openness sub-dimensions of personality traits. *F*-values for the sub-dimensions of personality traits (agreeableness, extraversion, conscientiousness, neuroticism, and openness) acquired using Levene's test for equality of variance were 1.844, .495, 3.434, .302, and .077. All *F*-values exceeded a 0.5 level of significance. The *t*-values and significance of personality traits were then used to determine and analyze results. The *t*-values for agreeableness, extraversion, conscientiousness, neuroticism, and openness were 1.108, .573, .187, -.553, and -.647, respectively, exhibiting no significance. The data are shown in Table 1.

Table 1. Test results for the differences in personality traits caused by overseas experience

Research dimension	Mean		<i>F</i> -value	Sig. <i>F</i>	<i>t</i> -value (two-tailed)	<i>p</i> -value
	(1)Yes ( <i>N</i> = 65)	(2)No ( <i>N</i> = 45)				
Agreeableness	3.5308	3.3778	1.844	.177	1.108	.270
Extraversion	3.1949	3.0963	.495	.483	.573	.568
Conscientiousness	3.4500	3.4222	3.434	.067	.187	.852
Neuroticism	3.3333	3.4222	.302	.584	-.553	.515
Openness	3.1179	3.2148	.077	.782	-.647	.519

Note: \* =  $p < .05$ , \*\* =  $p < .01$ , and \*\*\* =  $p < .001$ .

B. An examination of whether various overseas experiences caused differences in the value commitment, effort commitment, and retention commitment subdimensions of work attitude. The *F*-values of value commitment, effort commitment, and retention commitment acquired by applying Levene's test for equality of variance were .22, 1.135, and 1.579, respectively. All *F*-values exceeded a 0.5 level of significance. The *t*-values and commitment significances were used to determine and analyze the results. The *t*-values of the three variables were -.378, .348, and -1.435, respectively, exhibiting no significance. The data are

shown in Table 2.

### (2) One-way analysis of variance (ANOVA)

- i. An examination of whether varying nationality caused significant differences in personality traits and work attitude. One-way ANOVA was employed to examine whether employers' views and perceptions of the agreeableness, extraversion, conscientiousness, neuroticism, and openness sub-dimensions of personality traits for foreign caregivers of four nationalities differed. According to Table 3, the *F*-values for the



Table 2. Test results for the work attitude differences caused by overseas experiences

Research dimension	Mean		F-value	Sig. F	t-value (two-tailed)	p-value
	(1) Yes (N = 65)	(2) No (N = 45)				
Value commitment	3.5138	3.5644	.225	.636	-.378	.706
Effort commitment	3.3692	3.3185	1.135	.289	.348	.729
Retention commitment	3.3846	3.6111	1.579	.212	-1.435	.154

Note: \* =  $p < .05$ , \*\* =  $p < .01$ , and \*\*\* =  $p < .001$

Table 3. Test results for the personality trait differences caused by nationality

Research dimension	Group	Sample size	Mean	F-value	p-value	Post hoc comparisons
Agreeableness	(1) Indonesian	81	3.4877	1.310	.274	N
	(2) Filipino	14	3.6250			
	(3) Vietnamese	15	3.2167			
	(4) Thai	0	0.000			
Extraversion	(1) Indonesian	81	3.2263	1.497	.228	N
	(2) Filipino	14	3.1190			
	(3) Vietnamese	15	3.8000			
	(4) Thai	0	0.000			
Conscientiousness	(1) Indonesian	81	3.4907	1.149	.321	N
	(2) Filipino	14	3.4286			
	(3) Vietnamese	15	3.1667			
	(4) Thai	0	0.000			
Neuroticism	(1) Indonesian	81	3.3868	.095	.910	N
	(2) Filipino	14	3.3095			
	(3) Vietnamese	15	3.3333			
	(4) Thai	0	0.000			
Openness	(1) Indonesian	81	3.1481	.200	.819	N
	(2) Filipino	14	3.0952			
	(3) Vietnamese	15	3.2667			
	(4) Thai	0	0.000			

Note: \* =  $p < .05$ , \*\* =  $p < .01$ , and \*\*\* =  $p < .001$ ; N indicates that post hoc comparisons were not required, and S indicates that no significant differences were observed following post hoc comparisons.

variables were 1.310 ( $p$ -value = .274), 1.497 ( $p$ -value = .228), 1.149 ( $p$ -value = .321), .095 ( $p$ -value = .910), and .200 ( $p$ -value = .819), and none of the values achieved a level of significance. This indicates that the five variable subdimensions of personality traits are not perceived differently because of nationality differences. Therefore, Scheffé's post hoc comparisons were not required.

ii. According to Table 4, the  $F$ -values for value commitment, effort commitment, and retention commitment (the three subdimensions of work attitude) regarding different nationalities were .875 ( $p$ -value = .420), .490 ( $p$ -value = .614), and .257 ( $p$ -value = .744). None of the values reached a level of significance. This indicates that employer perceptions and views of the subdimensions for work attitude (value

commitment, effort commitment, and retention commitment) do not change because of differences in nationality. Consequently, Scheffe's post hoc comparisons were not required.

(3) Validity analysis

Regarding validity, we employed the maximum likelihood estimation (MLE) of confirmatory factor

analysis (CFA) to conduct goodness-of-fit tests of the measurement model for each dimension to verify whether the dimensions possessed sufficient convergent and discriminant validity.

A. Convergent validity analysis

We conducted assessments using the recommended convergent validity analysis criteria

Table 4. Test results for work attitude differences caused by nationality

Research dimension	Group	Sample size	Mean	F-value	p-value	Post hoc comparisons
Value commitment	(1) Indonesian	81	3.4938	.875	.420	N
	(2) Filipino	14	3.7571			
	(3) Vietnamese	15	3.5467			
	(4) Thai	0	0.000			
Effort commitment	(5) (1) Indonesian	81	3.3909	.490	.614	N
	(6) (2) Filipino	14	3.2381			
	(7) (3) Vietnamese	15	3.2222			
	(8) (4) Thai	0	0.000			
Retention commitment	(9) (1) Indonesian	81	3.4599	.257	.774	N
	(10) (2) Filipino	14	3.4286			
	(11) (3) Vietnamese	15	3.6167			
	(12) (4) Thai	0	0.000			

Note: \* =  $p < .05$ , \*\* =  $p < .01$ , and \*\*\* =  $p < .001$ ; N indicates that post hoc comparisons were not required, and S indicates that no significant differences were observed following post hoc comparisons.

established by Anderson and Gerbing [2], the CFA evaluation standards proposed by Bagozzi and Yi [4], and the recommended data for the goodness-of-fit index specified by Gefen *et al.*, [12]. The evaluation criteria comprised: (1) a goodness-of-fit index (GFI), normed fit index (NFI), and comparative fit index (CFI) that exceeded 0.9, with root mean square residuals (RMSR) below 0.05; (2) all indices possessed significant factor loading; (3) all dimensions possessed a composite reliability (CR) that exceeded 0.7; and (4) the average variance extracted (AVE) exceeded 0.5. The MLE was employed to estimate parameters and calculate the CR and AVE of each dimension.

i. Personality traits

When adjusting and correcting personality trait factors, items with standardized factor loadings that were negative or lower than 0.5 were excluded. The adjusted measurement model's RMR = 0.060, which was slightly higher than 0.05. In addition, the GFI, NFI, and CFI were 0.752, 0.816, and 0.872, respectively. The NFI and CFI exceeded 0.8 (GFI did not), and the factor loadings for all the measurement indices achieved significance. The CR and AVE (0.8731, 0.8734; 0.8995, 0.7417 and 0.8229; and 0.6386, 0.6970, 0.6914, 0.4939 and 0.6126) exceeded 0.7 and 0.5, respectively. Therefore, the data analysis results indicated that the convergent validity of the personality traits scale



was acceptable.

ii. Work attitude

The *RMR* of the work attitude measurement model = 0.070, which was slightly higher than 0.05. In addition, the *GFI*, *NFI*, and *CFI* were 0.682, 0.807, and 0.841. The *NFI* and *CFI* both exceeded 0.8 (*GFI* did not), and factor loadings of all the measurement indices achieved significance. The *CR* and *AVE* (0.8737, 0.8381 and 0.9233; and 0.5862, 0.6344 and 0.7531) exceeded 0.7 and 0.5, respectively. Therefore, the data analysis results indicated that the work attitude scale showed unacceptable convergent validity.

iii. Work performance

The *RMR* of the work performance measurement model = 0.052, which was slightly higher than 0.05. In addition, the *GFI*, *NFI*, and *CFI* were 0.745, 0.807, and 0.847. The *NFI* and *CFI* exceeded 0.8 (*GFI* did not), and factor loadings of all the measurement indices achieved significance. The *CR* and *AVE* (0.8972 and 0.9065; and 0.5967 and 0.6209) exceeded 0.7 and 0.5, respectively. Therefore, the data analysis results indicated that the work performance scale showed unacceptable convergent validity.

iv. Work environment

Items with standardized factor loadings that were negative or lower than 0.5 were excluded following correction and adjustment for the work environment dimension. The adjusted measurement model showed *RMR* = 0.056, which was slightly higher than 0.05. In addition, the *GFI*, *NFI*, and *CFI* were 0.824, 0.663, and 0.693, respectively. The *NFI* and *CFI* did not reach 0.8, and factor loadings of all the measurement indices achieved significance. The *CR* and *AVE* (0.5424, 0.5811 and 0.6397; and 0.2854, 0.3169 and 0.4729) did not exceed 0.7 and 0.5, respectively. Therefore, the data analysis results indicated that the work environment scale showed

unacceptable convergent validity.

However, because work environment was a moderating variable, it was not included in the overall SEM for consideration. Consequently, that the convergent and discriminant effects of this model were poor did not influence the overall structural model analysis.

v. Homecare guidance

The *RMR* of the homecare guidance measurement model = 0.032, which was lower than 0.05. In addition, the *GFI*, *NFI*, and *CFI* were 0.748, 0.897, and 0.934. The *GFI* was lower than 0.8, and the factor loadings of all the measurement indices achieved significance. The *CR* and *AVE* (0.9774, 0.9668 and 0.9661; and 0.8443, 0.8793 and 0.8261) exceeded 0.7 and 0.5, respectively. Therefore, the data analysis results indicated that the convergent validity of the homecare guidance scale was acceptable.

B. Discriminant validity

In this study, we conducted tests following the two criteria for discriminant validity proposed by Gaski and Nevin [11], that is, (1) the correlation coefficients between two dimensions are lower than 0.85; and (2) the correlation coefficients of two dimensions are lower than the Cronbach's  $\alpha$  reliability coefficients for the individual dimensions. These criteria indicate that two dimensions exhibit discriminant validity. We also proposed a third criterion for testing discriminant validity based on the method adopted by Fornell and Larcker [10], which was appropriate to the other two criteria. The results showed superior discriminant validity for all dimensions, as shown in Table 5.

(4) Hierarchical regression analysis

A. The moderating effect of the work environment (Model 1)

According to the ANOVA results, the effects of the overall regression model achieved a level of

significance ( $F$ -value = 91.619;  $p$ -value = .000 < .05), indicating that the overall regression model also possessed statistical significance. Furthermore, the adjusted coefficient of determination was 0.624, demonstrating that the explanatory power of the overall model reached 62.4%. The effective explanatory variance of the regression model's predictor variables (work attitude and interaction variables) for the dependent variable (work performance) was 62.4%. Thus, the interaction variable achieved significant difference ( $\beta = 0.589$ ,  $p < .05$ ), indicating a high positive moderating effect.

**B. The moderating effect of homecare guidance (Model 2)**

According to the ANOVA results, the effects of the overall regression model achieved a level of significance ( $F$ -value = 80.046;  $p$ -value = .000 < .05), indicating that the overall regression model also possessed statistical significance. Furthermore, the adjusted coefficient of determination was 0.592,

indicating that the explanatory power of the overall model reached 59.2%. The effective explanatory variance of the regression model's predictor variables (work attitude and interaction variables) for the dependent variable (work performance) was 59.2%; thus, the interaction variable did not achieve significant difference ( $\beta = 0.161$ ,  $p > .05$ ), indicating that no moderating effects occurred (as shown in Fig. 3).

**5. Structural Equation Modeling (SEM)**

**(1) Results analysis**

**A. Theoretical model evaluation**

- i. Regarding model goodness-of-fit evaluations, for this study, we conducted assessments based on the perspective of Bagozzi and Yi [4] using the following three approaches: (a) preliminary fit criteria, (b) overall model fit, and (c) fit of internal model structure. These three assessment approaches are explained below

Table 5. Results of discriminant validity analysis and variable correlation coefficients

Dimension	Agreeableness	Extraversion	Conscientiousness	Neuroticism	Openness	Value commitment	Effort commitment	Retention commitment	Task performance	Contextual performance
Agreeableness	1									
Extraversion	.689***	1								
Conscientiousness	.699***	.857***	1							
Neuroticism	.707***	.776***	.847***	1						
Openness	.646***	.683***	.657***	.742***	1					
Value commitment	.672***	.690***	.775***	.758***	.640***	1				
Effort commitment	.732***	.695***	.738***	.716***	.673***	.764***	1			
Retention commitment	.444***	.429***	.549***	.540***	.370***	.657***	.684***	1		
Task performance	.632***	.639***	.777***	.688***	.646***	.691***	.624***	.456***	1	
Contextual performance	.774***	.671***	.779***	.747***	.615***	.775***	.778***	.518***	.720***	1
Cronbach's $\alpha$	0.870	0.874	0.898	0.715	0.795	0.884	0.837	0.915	0.898	0.904

Note: CR represents composite reliability, AVE represents average extracted variance, and the lower triangle represents the



Pearson's coefficient.

Table 6. Analysis of the moderating effects of work environment and homecare guidance

Hierarchical regression analysis model		Model 1	Model 2
Dependent variable		Work performance	Work performance
Adjusted R-square		0.624	0.592
F-value		91.619***	80.046***
Research variables			
Work attitude	$\beta$ -value	.216	.647
	t-value	1.306	7.111***
Work attitude X work environment	$\beta$ -value	.589	⊙
	t-value	3.561***	⊙
Work attitude X homecare	$\beta$ -value	⊙	.161
	t-value	⊙	1.771

Note: \* =  $p < .05$ , \*\* =  $p < .01$ , and \*\*\* =  $p < .001$ ; ⊙ indicates that the specific regression model did not include a certain predictor variable.

a. Preliminary fit criteria

For this study, the following three criteria of preliminary fit were required for examination: (1) the error variance cannot be negative; (2) standardized factor loadings cannot be lower than 0.50 or over 0.95, and must achieve significance; and (3) the standard error cannot be excessively large. The assessment results for the overall theoretical models are shown in Table 7. These results indicated that the theoretical models' error variance was not negative, the standardized factor loadings were neither lower than 0.50 nor over 0.95, and achieved significance; and no significant or relatively high standard errors were observed. Therefore, the preliminary fit of the models adopted for this study was acceptable.

b. Overall model fit

The overall model fit was employed to assess the fit of the overall model and observed data. We referenced the recommendation of Hair *et al.*, [13] and evaluated the fit of the overall model and observed data using the following three indices: (1) Absolute fit measures, (2) incremental fit measures, and (3) parsimonious fit measures. Below we explain the content of the three indices.

(1) Absolute fit measures, as shown in Table 7. The absolute fit measure indices of the overall theoretical model in this study were  $\chi^2 = 109.850$ ,  $d.f. = 32$ ,  $\chi^2/d.f. = 3.433$ ,  $GFI = 0.859$ ,  $RMR = 0.026$ ,  $RMSEA = 0.149$ , and  $AGFI = 0.757$ . Besides RMSEA and AGFI approximating relevant standards, all other indexes were within appropriate standards.

(2) Incremental fit measures are shown in Table 7.

The incremental fit measure indices of the overall theoretical model in this study were  $NFI = 0.900$  and  $CFI = 0.926$ . Both indices were in an acceptable range. (3) Parsimonious fit measures are shown in Table 7. The parsimonious fit measure indices of the overall theoretical model in this study were  $PNFI = 0.640$  and  $PGFI = 0.500$ . Both indices were in an acceptable range ( $> 0.500$ ).

In conclusion, the combination of all index determinations indicated an acceptable overall model fit of the theoretical models employed in this study.

C. Fit of internal model structure

The CR coefficients for the overall dimensions of personality traits, work attitude, and work performance were 0.9321, 0.8692, and 0.839, respectively. All coefficients exceeded the 0.60

acceptance standard. The AVE coefficients of all dimensions were 0.7341, 0.6916, and 0.7231. All

Table 7. Measurement analysis results for the overall theoretical models [4]

Evaluated item	Standard value	This study
<b>1. Preliminary fit criteria: An examination of specification errors for the model; identifying problems and input errors.</b>		
1. No negative error variances	Yes	Match
2. Error variances achieved significance	Yes	Match
3. Absolute values between parameters are not too similar	Yes	Match
4. Factor loadings range between 0.5 and 0.9	Yes	Match
5. No significant or excessively large standard error	Yes	Match
<b>2. Overall model fit: An assessment of the fit of the overall model and the observed data.</b>		
1. Model Fit $\rightarrow$ CMIN : $\chi^2$ value significance level ; $p > .05$	A minimum chi-square value preferred $p$ -value exhibiting no significance	109.850 No match
2. Model Fit $\rightarrow$ CMIN $\rightarrow$ CMIN/df : $\chi^2/d.f.$	< 3	3.133 Approximate match
3. Model Fit $\rightarrow$ RMR, GFI $\rightarrow$ RMR (< 0.05) RMSE	< .05	0.026 Match
4. Model Fit $\rightarrow$ RMR, GFI $\rightarrow$ GFI (> 0.9) GFI (Hu and Bentler, 1999)	> .9 or .8	0.859 No match
5. Model Fit $\rightarrow$ RMR, GFI $\rightarrow$ AGFI (> 0.9) AGFI	> .9 or .8	0.757 Approximate match
6. Model Fit $\rightarrow$ Baseline Comparisons $\rightarrow$ NFI (> 0.9) NFI	> .9 or .8	0.9 match
7. Model Fit $\rightarrow$ Baseline Comparisons $\rightarrow$ CFI (> 0.5) CFI	> .9 or .8	0.926 match
8. Parsimony Normed Fit Index $\rightarrow$ PNFI (> 0.5) PNFI	> .5	0.640 match
9. Parsimony Goodness of Fit Index $\rightarrow$ PGFI (> 0.9) PGFI	> .5	0.500 match
10. Model Fit $\rightarrow$ RMSEA (< 0.05)	(.08 acceptable) < .05	0.149 No match
<b>3. Fit of internal structure model: An assessment of the significance of the estimated parameters in the models and the reliability of all indices and latent variables.</b>		
1. Individual item reliability (reliability analysis)	> .5	match
2. Latent variable CR (measurement model)	> .6	match
3. Latent variable AVE (measurement model)	> .5	match

coefficients exceeded the 0.50 acceptance standard. Consequently, the fit of the internal model structure for the theoretical models employed in this study was excellent.

ii. Hypothesis relationship verification

Regression coefficients of the overall path analysis based on Fig. 3 were employed for

hypothesis testing. The analysis results support the hypotheses proposed in this study, and all  $p$ -values achieved a .05 significance level. Additionally, "e" represents observation variable error and "er" represents latent variable error. The path coefficients and hypothesis verification results for the theoretical structural model are shown in Table 8.



Table 8. The path coefficient and hypothesis verification results for the theoretical structural model

Relationship between dimensions		Path coefficient	Corresponding hypothesis	Test results	
Personality traits	→	Work attitude	0.91***	H <sub>4</sub>	Supported
Work attitude	→	Work performance	0.46***	H <sub>1</sub>	Supported
Personality traits	→	Work performance	0.54***	H <sub>5</sub>	Supported

Note: \* =  $p < .05$ , \*\* =  $p < .01$ , and \*\*\* =  $p < .001$

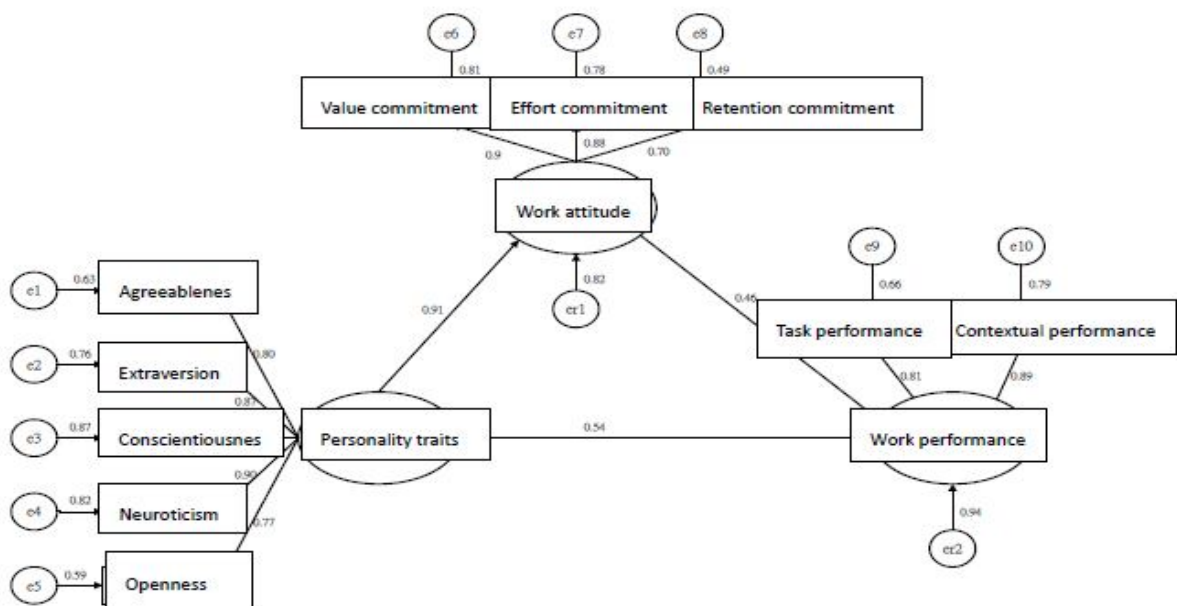


Figure 3. Relationship model of the samples

## 6. Conclusion and recommendations

### (1) Conclusion

For this study, we adopted the TAM proposed by Davis [9] as the basis of the theoretical framework and established an SEM for assessing domestic employers' (who are currently employing or have previously hired foreign caregivers) evaluations of foreign caregivers' work performance based on their employment perceptions. Additionally, we examined the correlation and interaction between personality

traits, demographic variables, work attitude, and work environment, and homecare guidance. We identified the key factors that influence foreign caregivers' work performance to enhance their overall work performance, and subsequently increase employers' willingness to employ foreign caregivers.

This study used a questionnaire survey for sampling. In addition, linear regression analysis was employed to examine the influence that foreign caregivers' personality traits and demographic variables had on their work attitude. The results

showed differences in foreign caregivers' personality traits. Of the five personality traits, conscientiousness approximated a significance influence for the overseas experience demographic variable. The nationality demographic variable showed no varying influences on personality traits and work attitude.

We employed linear hierarchical regression analysis to examine the influence that foreign caregivers' work attitude, housing and work environment factors, and homecare guidance had on their work performance. The results indicated that the receipt of homecare guidance from human resource agencies was insignificant for improving foreign caregivers' work attitude and work performance. However, the interaction between foreign caregivers and the family receiving homecare, and the housing and work environment, significantly influenced their work attitude and performance. Therefore, improving housing and working environments could positively enhance foreign caregivers' work performance.

In this study, we adopted an SEM to examine, analyze, and establish the path correlations and influential effects between the dimensions of the foreign caregivers' work performance structural model. The results indicated that the path correlations of employers' perceptions regarding foreign caregivers' personality traits, work attitude, and work performance fulfilled the frameworks defined in the hypotheses. Personality traits were the primary decisive factors considered by employers when selecting foreign caregivers and crucial to the overall model. The current work attitudes or performances of foreign caregivers were regarded as acceptable by employers.

Regarding work environment and homecare guidance, this study primarily examined the influence of the relative benefits, complexity, and

observability of employing foreign caregivers on foreign caregivers' work performance, and whether employers were satisfied with or could accept foreign caregivers' work performance. Applying hierarchical regression analysis, we found that no significant moderating effects existed between foreign caregivers' homecare guidance and their work attitude and performance. This indicates that to enhance foreign caregivers' performance, the homecare guidance services provided by human resource agencies must be improved. Appropriate housing and work environments had significant moderating effects on foreign caregivers' work attitude and performance. This indicates that the provision of a suitable working environment by employers influences foreign caregivers' behavioral performance. Therefore, the reinforcement and improvement of homecare guidance and holistic services in the foreign caregiver market should be the focus of future developments in related industries. Combining these objectives with traditional phone-based service methods can enhance employers' recognition and acceptance of service methods that effectively enhance foreign caregivers' work performance.

The difficulties and problems that foreign caregivers encounter during employment or daily life influence the quality of care they provide. This study focused on whether work environments influence foreign caregivers' work performance. The results indicated that employers currently employing foreign caregivers generally believed that providing a suitable work environment positively influences the adjustment of foreign caregivers' work attitude and performance. Therefore, the strategies adopted by the human resource industry should advocate the provision of suitable environments for foreign caregivers by employers to improve their work performance. The



results of this study can provide for the establishment of an SEM applicable to the evaluation model of foreign caregivers' work

performance. The results of the various hypotheses proposed in this study regarding relationships between dimensions are shown in Table 9.

Table 9. The results of the hypotheses proposed in this study regarding relationships between dimensions

Research Hypothesis	Accepted/Rejected
H1: Employers perceive that foreign caregivers' work attitude positively influences their work performance.	Accepted
H2: Employers perceive that foreign caregivers' demographic variables cause different influences for personality traits.	Rejected
H3: Employers perceive that foreign caregivers' demographic variables cause different influences for work attitudes.	Rejected
H4: Employers perceive that foreign caregivers' personality traits positively influence their work attitudes.	Accepted
H5: Employers perceive that foreign caregivers' personality traits positively influence their work performance.	Accepted
H6: The work environment provided by employers shows moderating effects for employees' work attitude and work performance.	Accepted
H7: Employers perceive that the homecare guidance provided by human resource agencies shows moderating effects on employees' work attitudes and work performance.	Rejected

Taiwan's government currently approves

## (2) Recommendations

For this study, we used empirical methods to comprehensively assess foreign caregivers' personality traits, demographic variables, work attitude, work environment, homecare guidance, and work performance. Our evaluation results for foreign caregivers' work performance can serve as a reference for related industries and for use in business development strategies, and provide a basis for employers when selecting and evaluating human resource agencies and foreign caregivers. This will enhance the quality of services provided by human resource agencies and increase foreign caregivers' work performance, thereby facilitating the overall development of the foreign caregiving profession.

### A. Recommendations for the human resource industry

i. Increase labor quality control and improve service quality

foreign laborers from countries such as Indonesia, the Philippines, Vietnam, Thailand, and Mongolia. Related industries should enhance the quality control of foreign laborers entering Taiwan; establish and control screening criteria, such as specific personality traits and demographic variables; and employ homecare guidance to increase service quality. This will enhance the industry's professional image, establish customer relationships, and increase customer loyalty.

ii. Enhance labor education and training, reinforce value-added services for market segmentation, and increase competitiveness

With increasing human resource demands, the human resource industry has actively promoted the entrance of foreign caregivers into Taiwan, resulting in an annual increase of foreign laborers. This increase has led to the rapid expansion of information transmissions between foreign laborers

in Taiwan. Consequently, both good and bad information has appeared and has led to the emergence of illegal intermediaries. In this study, we verified that employers are not confident of foreign caregivers' retention commitment. Therefore, after intermediaries or agencies have introduced and paired foreign caregivers with employers, translation assistance and work environment adaptation counseling are crucial factors that influence foreign caregivers' work stability. In this study, we hypothesized that foreign caregivers' personality traits, work attitudes, and work performance did not exhibit a positive moderating relationship with the homecare guidance provided by human resource agencies on employees' work attitude and work performance. However, this hypothesis was rejected. According to analysis, this may be because popular acceptance among employers for homecare guidance is lacking or guidance method and instructor modification is required. Therefore, human resource agencies should be more proactive in providing homecare guidance and training services after employers have hired foreign caregivers. This will reduce the time required for foreign caregivers to understand, learn, and adapt to the work content and environment. Thus, the above can be considered development objectives for enhancing service quality to cultivate an excellent reputation, trust, and favor among employers.

iii. Select suitable source countries and cooperating companies for foreign laborers to enhance industry performance and development

The results of this study indicate that employers' evaluations of foreign caregivers' work attitude and performance did not exhibit significant differences for the effects of demographic variables on personality traits and work attitudes. Therefore, the human resource industry should select more cooperating source countries and companies for foreign laborers entering Taiwan. Sufficient labor resources enable suitable laborers to be selected based on personality traits, and the flexible use of human resources to achieve applicability or good fit. This facilitates further improvements in industry performance and development.

#### B. Recommendations for employers

The results of this study show that foreign caregivers' demographic variables do not significantly influence their work performance. This indicates that when selecting personnel, their personality traits and work attitude should be the primary considerations to obtain superior work performance. The study hypotheses confirmed that

foreign caregivers' work environment factors exhibit a positive moderating relationship with their work attitudes and performance. Therefore, we recommend that employers provide suitable work environments to reduce the fluctuation of foreign caregivers' work attitudes, thereby enhancing their work performance.

#### C. Recommendations for the government

In response to elderly homecare issues caused by low birth rates, increases in the elderly population, and the slow development of various social welfare policies, the government has allowed foreign caregivers to work in Taiwan, resulting in an annual increase in foreign caregivers. Consequently, foreign caregivers have become an important channel for human resources that Taiwanese people depend on. The countries that are currently allowed to send foreign caregivers to Taiwan include Indonesia, the Philippines, Vietnam, Thailand, and Mongolia. The main source country of foreign caregivers in Taiwan is Indonesia. However, over-concentration typically results in the human resource industry facing insufficient sources for laborers. In addition, the arrival of Filipino caregivers is limited because of the language barrier, and the arrival of Vietnam caregivers has been banned or stopped for a number of years. Furthermore, Thai caregivers are less willing to work in Taiwan because of their conservative culture, and the entrance of Mongolian caregivers into Taiwan is not economically beneficial because of the vast distance between Taiwan and Mongolia. Therefore, we propose that the most effective method for the government to increase labor sources is to proactively increase the source countries for labor to thereby achieve the goal of choosing various suitable labor source countries and cooperating companies.

#### (2) Recommendations for future research

This study was conducted during the peak period of foreign caregivers working in Taiwan. Under foreign laborer policies, competent authorities have actively encouraged employers to directly hire foreign caregivers without considering potential obstacles caused by differences in language, diet, and customs. Human resource agencies are essential in facilitating overseas cultivation, selection, and training. These agencies are also crucial for providing assistance to foreign caregivers arriving in Taiwan, providing services such as on-the-job training, communication and counseling, assistance changing employers, and assistance in numerous emergency situations. Human resource agencies are a force that increases social stability. Even foreign caregivers who are directly hired experience many difficulties

related to their daily lives that require assistance. Thus, to increase the management development abilities of the human resource industry, employer and employee-related issues and government policy developments must be considered from various perspectives. Below we provide recommendations for future scholars when conducting more in-depth examinations of related topics.

A. Because of the limited sampling range, we could not comprehensively estimate employers' perceptions of foreign caregivers. Therefore, we recommend that future studies select employers from numerous regions to expand the sampling range and, thus, increase the diversity and objectivity of the sample sources.

B. Regarding homecare guidance, we only examined employers' perceptions of the effectiveness of the bilingual guidance provided by human resource agencies for foreign caregivers. However, we did not differentiate or assess the frequency of homecare guidance provision, whether the instructors were coherent and consistent, and the instructors' qualification. Future studies can examine the differences in guidance effectiveness acceptance based on the previously mentioned aspects to enhance the comprehensiveness of future research developments. This study was focused on foreign caregivers' personality traits, demographic variables, work attitudes, work environment, homecare guidance, and work performance as perceived by employers, examining the influences of these dimensions. Finally, external factors, such as perceptions of foreign caregivers' regarding the influence of their personality traits on their work, work content and amount, the difficulty of treating the illness of those receiving care, and recreational space, were not considered. Thus, these aspects are worthy of further research and examination.

## References

- [1] S. Anderson, *The Organization of Phonology*, New York: Academic Press, 1984.
- [2] J. C. Anderson, and D. W. Gerbing, "Structural Equation Modeling in Practice: A Review and Recommended Two-step Approach," *Psychological Bulletin*, Vol. 103, No. 3, 1988, pp. 411-423.
- [3] M. R. Barrick, and M. K. Mount, "The Five Personality Dimensions and Job Performance: A Meta-analysis," *Personnel Psychology*, Vol. 44, 1991, pp. 1-26.
- [4] R. P. Bagozzi, and Y. Yi, "On the Evaluation of Structural Equation Models," *Journal of the Academy of Marketing Science*, Vol. 16, No. 1, 1988, pp. 74-94.
- [5] W. C. Borman, and S. J. Motowidlo, "Expanding the Criterion Domain to Include Elements of Contextual Performance," In N. Schmitt and W. C. Borman (Eds), *Personnel Selection in Organizations*, San Francisco: Jossey-Bass, 1993, pp. 71-98.
- [6] J. P. Campbell, "Modeling the Performance Perdition Problem in *Industrial and Organizational Psychology*. In M. D. Dunnette and L. M. Hough, Vol. 1, No. 2, 1990, pp. 687-732.
- [7] C. J. Chiou, S. M. Hsu, and S. Z. Wu, 2003, "Needs of Home-care Primary Caregivers," *The Journal of Health Science*, Vol. 5, No. 1, 2003 pp. 12-24 (in Chinese).
- [8] P. T. Costa, R. R. McCrae and C. M. Busch, "Evaluating Comprehensiveness in Personality System: The California Q-set and the Five-factor Model," *Journal of Personality*, 1986, Vol. 54, pp. 430-446.
- [9] F. D. Davis, "Perceived Usefulness, Perceived Ease of Use and User Acceptance of Information Technologies," *MIS Quarterly*, Vol. 13, No. 3, 1989, pp. 319-340.
- [10] C. Fornell, and D. F. Larcker, 1981, "Evaluating Structural Equation Models with Unobservable Variables and Measurement Error," *Journal of Marketing Research*, Vol. 18, No. 3, 1981, pp. 39-50.
- [11] J. F. Gaski, and J. R. Nevin, 1985, "The Differential Effects of Exercised and Unexercised Power Sources in a Marketing Channel," *Journal of Marketing Research*, Vol. 22, No. 2, 1985, pp. 130-142.
- [12] D. Gefen, D. Straub, and M. C. Boudreau, "Structural Equation Modeling and Regression: Guidelines for Research Practice," *Communications of AIS*, Vol. 4, No. 7, 2000, pp. 1-78.
- [13] J. F. Jr. Hair, W. C. Black, B. J. Babin, R. E. Anderson, and R. L. Tatham, *Multivariate Data*

*Analysis*, Prentice Hall, Englewood Cliffs, N. J. 2006.

[14] D. B.Hershenson, "Work Adjustment, Disability and the Three R. S. of Vocational Rehabilitation: A Conceptual Model,"*Rehabilitation Counseling Bulletin*, Vol. 25, No. 2, 1981, pp. 91-97.

[15] Y. C.Hsu, andJ. J.Wang, "Pre-occupational Nursing Education for Vietnamese Foreign Labors,"*The Journal of Long Term Care*, Vol. 8, No. 1, 2003, pp. 79-88 (in Chinese).

[16] T.L.Huang,*Research of the Relationship among Personality Traits, Job Stress, Job Involvement, Professional Commitment and Job Performance of Administrative Staff in Hospital*, Master's Thesis, Graduate Institute of the College of Management, Nanhua University, 2003 (in Chiese).

[17] Y.D.Lee, C.M.Chung, and Y. L.Lin, A Research on the Measuring of Employees' Organizational Commitment in Taiwanese Business,*Journal of Cheng Kung University (Humanities and Social Sciences)*, Vol. 35, 2000, pp. 133-157 (in Chinese).

[18] I. C.Li, L. Y.Wu, L. C. Chang, andY. C. Chen,"Application of Empowering Education in Long-term Care Facilities: The Experience with Foreign Nurse Aides,"*The Journal of Nursing*, Vol. 52, No. 6,2005, pp. 23-29 (in Chinese).

[19] J. P.Meyer, "Causal Attribution for Success and Failure: A Multivariate Investigation of Dimensionality, Formation and Consequences,"*Journal of Personality and Social Psychology*, Vol. 38, 1980, pp. 704-718.

[20] S. P.Robbins, "Learning Outcomes of Integrate Preceptorship,"*Nursing Connections*, Vol. 12, No. 3,1999, pp. 19-34

# Studies on Fitting Fuzzy Multiple Regression Models

Liang-Hsuan Chen, Chia-Jung Chang

*Department of Industrial and Information Management  
National Cheng Kung University, Tainan, Taiwan, R.O.C.  
lhchen@mail.ncku.edu.tw, [r38991028@mail.ncku.edu.tw](mailto:r38991028@mail.ncku.edu.tw)*

## **Abstract**

*Fuzzy regression models (FRMs) were developed by a number of scholars to establish the relationship between fuzzy response and/or fuzzy explanatory variables. FRMs were applied to solve real problems in the existing literature. However, few studies have considered the variable selection method and the performance measurement of FRMs to identify effective subsets of explanatory variables. This research investigates the quality of fit and suitable variable selection procedure in the FRM. Fuzzy regression is used to describe the contribution of the corresponding fuzzy explanatory variables in explaining the fuzzy response variable. First, an FRM is introduced to derive a theorem. Taking into consideration all possible FRMs, two indices (i.e.,  $\mathfrak{R}^2$  and adjusted  $\mathfrak{R}^2$ ) are proposed to evaluate the fitting performance of the potential FRM for selecting the best model. Based on the idea of the average marginal contribution, a stepwise selection procedure is developed to efficiently find a suitable subset of explanatory variables without requiring the fitting of all of the possible FRM. Finally, we provide an example for verification.*

## **1. Introduction**

In practical cases, the collected data often lack precise information and are thus vague. The relationship between explanatory and response variables can be considered as a form of regression equation, called the fuzzy regression model (FRM). The FRM with fuzzy coefficients, first proposed by Tanaka et al. [1], are developed by a linear programming model. Various methods have been proposed for the construction of FRMs, such as linear programming method [2-5], Least-squares method [6-11], mathematical programming [12-13] and the fuzzy random variable method [14-17]. However, these studies devoted to the study of the model construction and the evaluation of coefficient under assuming that the explanatory variables were subjectively agreed upon by an expert or analyst. In practice, explanatory

variables do not have equal importance. Sometimes, analysts must include most of the explanatory variables to make the estimation errors small or drop them to reduce the costs involved in obtaining information. Therefore, analysts have to judge which and how many explanatory variables should be included in the eventual FRM.

Some fitting indices and procedures have been suggested for selecting the best FRM, such as the index of confidence (*IC*) to measure the degree of the variation of fuzzy number with forward selection procedure [18], branch and bound algorithm [19], coefficient of determination ( $R^2$ ) and  $C_p$  under the use of all possible regression models [20, 21]. However, these approaches cannot simultaneously handle models whose response variable is fuzzy or numeric and those explanatory variables are fuzzy or numeric. Those are limited to the forward selection procedure or all possible regression method. Based on our previous work [6], which defined the concept of distance and a fuzzy adjustment term  $\delta$  as well as a least-squares method is used to solve the numeric regression coefficients, this study proposed the fitness indices ( $\mathfrak{R}^2$ , adjusted  $\mathfrak{R}^2$ ) to find the regression model with the largest interpretation ability. A stepwise variable selection method is developed by employing an objective index, called the marginal effect (*ME*), to efficiently find the best subset of explanatory variables. The proposed approaches can be applied to identify FRMs associated with various data types (fuzzy or numeric explanatory and response variable).

The rest of this paper is organized as follow. Section 2 introduces the estimated FRM, least-squares method and the concept of distance by Chen and Hsueh. In Section 3, an FRM is given to derive the estimator of fuzzy error terms. In Section 4, Fitness measures for all possible FRMs and a stepwise selection method are proposed to find a suitable subset. Finally, an example is provided to demonstrate the feasibility and the conclusion is given.

## 2. Fuzzy estimated model and distance measure

In a fuzzy regression system, the estimated FRM with numerical coefficients is introduced as:

$$\hat{Y}_i = b_0 + b_1 \tilde{X}_{i1} + b_2 \tilde{X}_{i2} + \dots + b_p \tilde{X}_{ip}, \quad i = 1, \dots, n \quad (1)$$

where  $\hat{Y}_i$  and  $\tilde{X}_{ij}$  represent the estimated fuzzy response variable and the  $j$ th fuzzy explanatory variable of the  $i$ th fuzzy observation, respectively. This study applies the idea of Chen and Hsueh in 2009, who used a triangular fuzzy adjustment term  $\tilde{\delta}$  in the estimated FRM (1). The fuzzy adjustment term can be used to resolve the large fuzzy error for a fuzzy response when the explanatory variables are numeric. Triangular fuzzy numbers are a generalized type of fuzzy set and are commonly used in practical applications. The applied model can be written as an extension of the estimated FRM. That is:

$$\hat{Y}_i' = b_0 + b_1 \tilde{X}_{i1} + b_2 \tilde{X}_{i2} + \dots + b_p \tilde{X}_{ip} + \tilde{\delta}, \quad i = 1, \dots, n$$

where  $\tilde{\delta} = (\delta_l, \delta_m, \delta_u)$ , the membership degrees are  $\mu_{\tilde{\delta}}(\delta_m) = 1$ ,  $\mu_{\tilde{\delta}}(\delta_l) = 0$ , and  $\mu_{\tilde{\delta}}(\delta_u) = 0$ . The three parameters  $\delta_l$ ,  $\delta_m$ , and  $\delta_u$  in  $\mu_{\tilde{\delta}}$  are regarded as parameters to be determined.

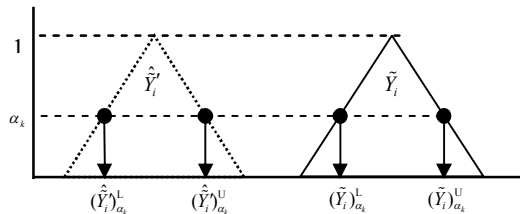


Figure 1. Difference in membership functions of estimated and observed responses.

In order to find the estimators  $b_0, b_1, \dots, b_p$  and  $\tilde{\delta}$  of the regression parameters, this study employs the distance concept of  $\alpha$ -cuts between a pair of fuzzy numbers and the least-squares method, as suggested by Chen and Hsueh [6], to determine the estimated parameters by minimizing the sum of  $n$  squared distances between the observed ( $\tilde{Y}_i$ ) and the estimated responses ( $\hat{Y}_i'$ ). For the given  $\tilde{Y}_i$  and  $\hat{Y}_i'$ , the residual distance between  $\tilde{Y}_i$  and  $\hat{Y}_i'$  at the  $k$ th  $\alpha$ -level for the  $i$ th observation is calculated as  $\left[ \left( (\hat{Y}_i')_{\alpha_k}^L - (\tilde{Y}_i)_{\alpha_k}^L \right)^2 + \left( (\hat{Y}_i')_{\alpha_k}^U - (\tilde{Y}_i)_{\alpha_k}^U \right)^2 \right] / 2$ , as

illustrated graphically in Figure 1. A group of  $\alpha$ -cuts can describe a fuzzy number. Therefore, the residual for one case is considered as the average from several  $\alpha$ -cuts. Then, the mean squared error for the  $i$ th observation calculated using  $m$   $\alpha$ -cuts as

$$E_i = \frac{1}{2m} \sum_{k=0}^{m-1} \left[ \left( (\hat{Y}_i')_{\alpha_k}^L - (\tilde{Y}_i)_{\alpha_k}^L \right)^2 + \left( (\hat{Y}_i')_{\alpha_k}^U - (\tilde{Y}_i)_{\alpha_k}^U \right)^2 \right].$$

Consequently, the total mean squared error ( $\sum_i E_i$ ) for all observations is used as a measure of the residual squared distance between the observed and the estimated responses:

$$\sum_{i=1}^n E_i = \sum_{i=1}^n \frac{1}{2m} \sum_{k=0}^{m-1} \left[ \left( (\hat{Y}_i')_{\alpha_k}^L - (\tilde{Y}_i)_{\alpha_k}^L \right)^2 + \left( (\hat{Y}_i')_{\alpha_k}^U - (\tilde{Y}_i)_{\alpha_k}^U \right)^2 \right] \quad (3)$$

Following the least-squares method to minimize  $\sum_i E_i$ , the regression coefficients  $b_j, j = 0, 1, \dots, p$ ,  $\delta_l$ ,  $\delta_m$ , and  $\delta_u$  can be determined by differentiation (3) and setting the results equal to zero based on a few  $\alpha$ -cuts. Finally, the coefficients can be obtained by solving differential equations.

## 3. Fuzzy regression model for the given observations

In order to establish a suitable measure index and selection procedure, a corresponding FRM for the given fuzzy observed responses is proposed as:

$$\tilde{Y}_i = \beta_0 + \beta_1 \tilde{X}_{i1} + \beta_2 \tilde{X}_{i2} + \dots + \beta_p \tilde{X}_{ip} + \tilde{\Delta}_i \quad (4)$$

where  $\tilde{\Delta}_i = (\Delta_{il}, \Delta_{im}, \Delta_{iu})$ ,  $i = 1, \dots, n$  is the unknown true error associated with the  $i$ th data, called the fuzzy error term. The estimator of fuzzy error term is derived below.

*Theorem 1:*

For the FRM (4) with the unknown fuzzy error term  $\tilde{\Delta}_i$ , to prove  $\tilde{\delta}$  is equal to  $\bar{\Delta}$ , the value  $\bar{\Delta}$  is used as the estimator of the fuzzy error term.

*Proof:*

According to the FRM (4), using  $\alpha$ -cuts, the lower bound of  $\tilde{Y}_i$  at the  $\alpha_k$ -level (let  $\alpha_k = k/m - 1, k = 0, 1, \dots, m - 1$ ) is written as:

$$(\tilde{Y}_i)_{\alpha_k}^L = \beta_0 + \sum_{j=1}^p \beta_j (\tilde{X}_{ij})_{\alpha_k}^L + \tilde{\Delta}_{i\alpha_k}^L \quad (5)$$

Referring to (5) and taking the mean of  $(\tilde{Y}_i)_{\alpha_i}^L$ ,  $(\tilde{X}_{ij})_{\alpha_i}^L$ , and  $\tilde{\Delta}_{i\alpha_i}^L$  as  $(\bar{Y})_{\alpha_i}^L = \sum_{i=1}^n (\tilde{Y}_i)_{\alpha_i}^L / n$ ,  $(\bar{X}_j)_{\alpha_i}^L = \sum_{i=1}^n (\tilde{X}_{ij})_{\alpha_i}^L / n$ , and  $\bar{\Delta}_{\alpha_i}^L = \sum_{i=1}^n \tilde{\Delta}_{i\alpha_i}^L / n$ , respectively, the lower bound of  $\bar{Y}$  can be written as:

$$\begin{aligned} (\bar{Y})_{\alpha_i}^L &= \beta_0 + \sum_{i=1}^n \sum_{j=1}^p \beta_j (\tilde{X}_{ij})_{\alpha_i}^L / n + \sum_{i=1}^n \tilde{\Delta}_{i\alpha_i}^L / n \\ &= \beta_0 + \sum_{j=1}^p \beta_j (\bar{X}_j)_{\alpha_i}^L + \bar{\Delta}_{\alpha_i}^L \end{aligned} \quad (6)$$

Recall the differential equations of coefficients. For simplicity, 2  $\alpha$ -cuts ( $m=2$ ) are used below. Hence, we get one of differential equations:

$$b_0 + \delta_l = \bar{Y}_{\alpha_0}^L - \sum_{j=1}^p b_j (\bar{X}_j)_{\alpha_0}^L \quad (7)$$

Recall equation (6) and substitute  $b_1, \dots, b_p$  for  $\beta_1, \dots, \beta_p$ , the lower bound of  $\bar{Y}$  at the  $\alpha_0$ -level = 0 for 2  $\alpha$ -cuts ( $m=2$ ) can be rewritten as:

$$(\bar{Y})_{\alpha_0}^L = b_0 + \sum_{j=1}^p b_j (\bar{X}_j)_{\alpha_0}^L + \bar{\Delta}_{\alpha_0}^L \quad (8)$$

where  $\bar{\Delta}_{\alpha_0}^L = \frac{1}{n} \sum_{i=1}^n \tilde{\Delta}_{i\alpha_0}^L = \frac{1}{n} \sum_{i=1}^n \Delta_{i0} = \bar{\Delta}_l$ . Comparing (7)

with (8) yields  $\delta_l = \bar{\Delta}_l$ . Similarly,  $\delta_u = \bar{\Delta}_u$  and  $\delta_m = \bar{\Delta}_m$  can be obtained by considering 2  $\alpha$ -cuts. Therefore,  $\tilde{\delta}$  is equal to  $\bar{\Delta}$ .

#### 4. Fitness measure and variable selection

In classical regression, the coefficient of determination  $R^2$  is widely suggested as a convenient measure for measuring how well the regression model fits. In this study, we introduced the index of interpretation ability ( $\mathfrak{R}^2$ ) as a measure of how much information has been captured when a subset of explanatory variables is employed. Hence, the larger  $\mathfrak{R}^2$  is, the more the total explanation of the response variable is contained by the use of information about explanatory variables. A useful relationship is defined below for developing the fitting indices.

*Definition 1:*

With the concept of distance obtained by  $m$   $\alpha$ -cuts, the total sum of the squared distance for all observations can be decomposed into two components

that are the sum of squares due to the regression and the residual sum of squares, the following can be defined:

(1) The total sum of squared distance (*SST*) between the  $\tilde{Y}_i$  and fuzzy mean  $\bar{Y}$  is defined as

$$SSD(\tilde{Y}_i, \bar{Y}) \equiv \sum_{i=1, \dots, n} \frac{1}{2m} \sum_{k=0}^{m-1} \left[ \left( (\tilde{Y}_i)_{\alpha_i}^L - (\bar{Y})_{\alpha_i}^L \right)^2 + \left( (\tilde{Y}_i)_{\alpha_i}^U - (\bar{Y})_{\alpha_i}^U \right)^2 \right],$$

which represents the total explanation for  $n$  fuzzy observed responses.

(2) The sum of squares due to the regression (*SSR*) associated with  $\hat{Y}_i'$  and  $\bar{Y}$  is defined as

$$SSD(\hat{Y}_i', \bar{Y}) \equiv \sum_{i=1, \dots, n} \frac{1}{2m} \sum_{k=0}^{m-1} \left[ \left( (\hat{Y}_i')_{\alpha_i}^L - (\bar{Y})_{\alpha_i}^L \right)^2 + \left( (\hat{Y}_i')_{\alpha_i}^U - (\bar{Y})_{\alpha_i}^U \right)^2 \right],$$

which represents a partitioning of the total explanation when a subset of  $\tilde{X}$  is taken into account in a model.

(3) The residual sum of squares (*SSE*) associated with  $\tilde{Y}_i$  and  $\hat{Y}_i'$  is defined as

$$SSD(\tilde{Y}_i, \hat{Y}_i') \equiv \sum_{i=1, \dots, n} \frac{1}{2m} \sum_{k=0}^{m-1} \left[ \left( (\tilde{Y}_i)_{\alpha_i}^L - (\hat{Y}_i')_{\alpha_i}^L \right)^2 + \left( (\tilde{Y}_i)_{\alpha_i}^U - (\hat{Y}_i')_{\alpha_i}^U \right)^2 \right],$$

which represents the other partitioning of the total explanation that is not yet explained in the model.

While the relationship of the sum of square deviations holds ( $SST=SSR+SSE$ ),  $\mathfrak{R}^2$  is considered as the proportionate reduction of the total explanation associated with the use of  $\tilde{X}$  to measure the interpretation ability of the model. The form is:

$$\mathfrak{R}^2 = \frac{SSR}{SST} \equiv \frac{\sum_{i=1}^n \frac{1}{2m} \sum_{k=0}^{m-1} \left[ \left( (\hat{Y}_i')_{\alpha_i}^L - (\bar{Y})_{\alpha_i}^L \right)^2 + \left( (\hat{Y}_i')_{\alpha_i}^U - (\bar{Y})_{\alpha_i}^U \right)^2 \right]}{\sum_{i=1}^n \frac{1}{2m} \sum_{k=0}^{m-1} \left[ \left( (\tilde{Y}_i)_{\alpha_i}^L - (\bar{Y})_{\alpha_i}^L \right)^2 + \left( (\tilde{Y}_i)_{\alpha_i}^U - (\bar{Y})_{\alpha_i}^U \right)^2 \right]} \quad (9)$$

Consequently, in order to adjust the effect on the number of explanatory variables to avoid an over-complicated model, the following modified measure is suggested:



$$\begin{aligned} \text{adjusted } \mathfrak{R}^2 &= 1 - \frac{SSE/n - (p+3)}{SST/n - 1} \\ &= 1 - (1 - \mathfrak{R}^2) \times \frac{n-1}{n-(p+3)} \end{aligned} \quad (10)$$

There are  $p+3$  parameters to be estimated in the model with  $b_1, b_2, \dots, b_p, b_0+\delta_1, b_0+\delta_m,$  and  $b_0+\delta_u$ . In this study, the maximum  $\mathfrak{R}^2$  and adjusted  $\mathfrak{R}^2$  are considered as criteria to select an appropriate regression model.

All possible regression approach enables us to examine each model. However, this is not economical when the number of possible explanatory variables is large. An efficient selection procedure is helpful to produce the suitable FRM. In this study, instead of using the methods of statistical inference, the concept of explanation is used to introduce a proportion index (11), that divides the extra sum of squares and the residual sum of squares by their associated numbers of estimated parameters.

$$\begin{aligned} ME_{(\tilde{X}_{p+1}|\tilde{X})} &= \frac{SSR(\tilde{X}_{p+1}|\tilde{X})/nf_{extra}}{SSE(\tilde{X})/nf_x} \\ &= \frac{[SSE(\tilde{X}) - SSE(\tilde{X} \cup \tilde{X}_{p+1})]/1}{SSE(\tilde{X})/q} \end{aligned} \quad (11)$$

where  $q=p+3$ ,  $\tilde{X} = \{\tilde{X}_j\}, j=1, \dots, p$  contains  $p$  explanatory variables in set form.  $nf$  represents the number of estimated parameters. Hence, the magnitude of  $ME$  is considered as the marginal effect of adding or removing an explanatory variable and compared to a predefined acceptable value ( $t$ ). A stepwise selection procedure is developed for deciding whether a variable should be included. The criteria for candidate variables  $\tilde{X}_{in}$  is: If  $ME_{(\tilde{X}_{in}|\tilde{X})} \geq t$ , then  $\tilde{X}_{in}$  is added to the model. The criteria for existing variables  $\tilde{X}_{out}$  after a candidate variable is added is: If  $ME_{(\tilde{X}_{out}|\tilde{X}\setminus\{\tilde{X}_{out}\})} \geq t$ , then  $\tilde{X}_{out}$  is retained in the model. Based on the average of the contribution, the average of the residual sum of squares is considered as a basis for comparison, the predefined value should be 1. Nevertheless, the value of  $t$  can be subjectively adjusted by experts with regard to cost concerns. The larger  $t$  is, the fewer explanatory variables are captured in the model.

## 5. Illustrative example

To demonstrate the feasibility of the proposed approaches, two  $\alpha$ -cuts ( $m=2$ ) are used.  $\mathfrak{R}^2$ , adjusted

$\mathfrak{R}^2$ , and  $ME$  are considered as the criteria to determine a suitable model and the best subset of explanatory variables.  $t=1$  is used as the threshold in the stepwise selection procedure.

*Example:*

This example was analyzed by D'Urso and Santoro [21] to measure the goodness of fit of the model, as listed in Table 2. According to (9) and (10),  $\mathfrak{R}^2$  and adjusted  $\mathfrak{R}^2$  associated with all possible FRMs are listed in Table 3.  $R^2, \bar{R}^2,$  and  $C_p$  are also listed in Table 4. The value of  $\mathfrak{R}^2$  and adjusted  $\mathfrak{R}^2$  are slightly lower than  $R^2$  and  $\bar{R}^2$ , respectively. Following the criteria (proposed here or by D'Urso and Santoro), the full model is chosen in this case. In addition, the  $C_p$  index is employed in D'Urso and Santoro as an alternative measure for coping with the drawbacks of  $R^2$ . Thus, a reduced model with  $X_1$  and  $X_2$  is considered as an alternative model on the practical concern.

**Table 2. Dataset used for example**

<i>O</i>	<i>X</i>	<i>X</i>	<i>X</i>	<i>Y</i>
<i>b.s.</i>	1	2	3	<i>Y</i>
		2		
1	7	6	6	(71.6, 78.5, 85.4)
		2	1	
2	1	9	5	(67.9, 74.3, 80.7)
		1	5	
3	1	6	8	(94.9, 104.3, 113.7)
		1	3	
4	1	1	8	(79.8, 87.6, 95.4)
			5	
5	7	2	6	(86.9, 95.5, 104.1)
		1	5	
6	1	5	9	(99.3, 109.2, 119.1)
			7	
7	3	1	7	(93.4, 102.7, 112)
			3	
8	1	1	2	(66.3, 72.5, 78.7)
			5	
9	2	4	8	(84.8, 93.1, 101.4)
		1	2	
0	1	2	4	(105.3, 115.9, 126.5)
			4	
1			4	(76.4, 83.8, 91.2)
		1	0	
1		1	6	
2	1	6	9	(102.7, 113.3, 123.9)
		1	1	
3	0	8	8	(99.5, 109.4, 119.3)

**Table 3. Subset selection of all possible models by the proposed criteria**

Proposed criteria	
-------------------	--



<i>et</i>	<i>Subs</i>	<i>SSE</i>	$\mathfrak{R}^2$	Adj $\mathfrak{R}^2$
		<i>SST=2729.6</i>		
	$X_1$	1,278	0.53	0.37
	$X_2$	85	15	53
	$X_3$	922.6	0.66	0.54
	$X_1, X_2$	2	20	93
	$X_1, X_3$	1,959	0.28	0.04
	$X_2, X_3$	.03	23	31
2	$X_1, X_2, X_3$	73.26	0.97	0.95
3	$X_1, X_2$	1,237	0.54	0.31
3	$X_1, X_3$	.76	65	98
3	$X_2, X_3$	436.1	0.84	0.76
3	$X_1, X_2, X_3$	9	02	03
2,3	$X_1, X_2, X_3$	62.18	72*	09*

“\*\*” indicates the best model based on criterion.

**Table 4. Subset selection of all possible models by D’Urso and Santoro**

<i>et</i>	<i>Subs</i>	D’Urso and Santoro’s criteria			
		<i>SS</i>	$R^2$	$\bar{R}^2$	<i>C</i>
		<i>SST=8190.8</i>			
	$X_1$	38	0.53	0.37	1
	$X_2$	15.0	42	90	78.9
	$X_3$	27	0.66	0.55	1
	$X_1, X_2$	40.4	54	39	27.1
	$X_1, X_3$	58	0.28	0.04	2
	$X_2, X_3$	66.4	38	50	77.8
2	$X_1, X_2, X_3$	17	0.97	0.96	5.
3	$X_1, X_2$	8.6	82	73	6*
3	$X_1, X_3$	36	0.54	0.32	1
3	$X_2, X_3$	91.1	94	40	74.9
3	$X_1, X_2, X_3$	12	0.84	0.76	5
3	$X_1, X_2$	73.1	46	69	8.4
2,3	$X_1, X_2, X_3$	14	0.98	0.96	6.
2,3	$X_1, X_2, X_3$	5.2	23*	96*	0

“\*\*” indicates the best model based on criterion.

For the proposed stepwise variable selection method, the related data is calculated step by step in Table 5. In step 1, three simple FRMs are constructed to examine which variables should be first included, the  $ME$  is obtained as  $ME_{(x_j|\emptyset)}, \forall j=1, \dots, 3$ . As mentioned earlier,  $t = 1$ .  $X_2$  with the largest  $ME(1.99)$  is more than 1. Therefore,  $X_2$  is added. In step 2, regression models with two variables are constructed, where  $X_2$  is one of the two variables.  $ME$  is obtained as

$ME_{(x_j|x_i)}, j=1, 3$ .  $X_1$  with the largest  $ME$  (3.68) exceeds 1. Therefore,  $X_1$  is also included. In step 3, the procedure examines whether the existing variable  $X_2$  should be removed after the new variable  $X_1$  has been included.  $ME$  (1.77) is obtained as  $ME_{(x_1|x_2)}$ . Since the value is more than 1,  $X_2$  is not removed. Finally, in step 4, the last variable  $X_3$  is added to the candidate model and a regression model with three variables is constructed. At this stage,  $ME$  (0.76) is obtained as  $ME_{(x_1|x_2, x_3)}$ . Since the value is less than 1,  $X_3$  is not included and the procedure is stopped because no more variables can be included or excluded. The reduced model is:

$$\hat{Y}^t = 1.47X_1 + 0.66X_2 + (43.90, 52.46, 61.02) \quad (12)$$

**Table 5. Subset selection by stepwise procedure for example**

<i>et</i>	<i>Subs</i>	<i>SSE</i>	Value of $ME$ at each step			
			step 1	step 2	step 3	step 4
		1,278.				
	$X_1$	85	1.59			
	$X_2$	922.62 <sup>in</sup>	1.99			
	$X_3$	1,959.				
	$X_2, X_3$	03	0.85			
1	$X_1, X_2, X_3$	73.26	*	3.68 <sup>in</sup>	1.7	
3	$X_1, X_2$	436.19		2.11		
2,3	$X_1, X_2, X_3$	62.18				0.7
2,3	$X_1, X_2, X_3$					6

“in” indicates that the candidate variables are chosen by the stepwise procedure.

“\*\*” indicates that the final subset is chosen by the stepwise procedure.

Here, the selected subset of  $\tilde{X}$  is equal to that obtained using the  $C_p$ . An appropriate model is efficiently obtained using the stepwise procedure, with only a small penalty in interpretation ability (decreased from 0.9772 to 0.9732).

## 6. Conclusions

This paper introduced a fuzzy regression model to derive the estimator of the fuzzy error term based on the definition of distance. Two assessment criteria ( $\mathfrak{R}^2$  and adjusted  $\mathfrak{R}^2$ ) were developed to evaluate the quality of fit of all potential FRMs. Based on the idea

of the average marginal contribution, the index  $ME$  was applied to the stepwise selection procedure to determine the best set of explanatory variables. The proposed approach is suitable for models with fuzzy/numeric explanatory variables and a fuzzy/numeric response variable.

## 7. References

- [1] Tanaka, H., et al., "Linear regression analysis with fuzzy model", *IEEE Transactions on Systems, Man and Cybernetics*, 12, 1982, pp. 903-907.
- [2] Sakawa, M., and Yano, H., "Multiobjective fuzzy linear regression analysis for fuzzy input-output data", *Fuzzy Sets and Systems*, 47(2), 1992, pp. 173-181.
- [3] Tanaka, H., "Fuzzy data analysis by possibilistic linear models", *Fuzzy Sets and Systems*, 24(3), 1987, pp. 363-375.
- [4] Tanaka, H., et al., "Possibilistic linear regression analysis for fuzzy data", *European Journal of Operational Research*, 40(3), 1989, pp. 389-396.
- [5] Tanaka, H., and Watada, J., "Possibilistic linear systems and their application to the linear regression model", *Fuzzy Sets and Systems*, 27(3), 1988, pp. 275-289.
- [6] Chen, L. H., and Hsueh, C. C., "Fuzzy Regression Models Using the Least-Squares Method Based on the Concept of Distance", *IEEE Transactions on Fuzzy Systems*, 17(6), 2009, pp. 1259-1272.
- [7] D'Urso, P., and Gastaldi, T., "A least-squares approach to fuzzy linear regression analysis", *Computational Statistics & Data Analysis*, 34, 2000, pp. 427-440.
- [8] Diamond, P., "Fuzzy least squares", *Information Sciences*, 46, 1988, pp. 141-157.
- [9] Diamond, P., and Körner, R., "Extended fuzzy linear models and least squares estimates", *Computers & Mathematics with Applications*, 33(9), 1997, pp. 15-32.
- [10] Kao, C. "Least-squares estimates in fuzzy regression analysis", *European Journal of Operational Research*, 148(2), 2003, pp. 426-435.
- [11] Wu, B., and Tseng, N. F., "A new approach to fuzzy regression models with application to business cycle analysis", *Fuzzy Sets and Systems*, 130(1), 2002, pp. 33-42.
- [12] Chen, L. H., and Hsueh, C. C., "A mathematical programming method for formulating a fuzzy regression model based on distance criterion", *IEEE Transactions on Systems Man and Cybernetics Part B-Cybernetics*, 37(3), 2007, pp. 705-712.
- [13] Nasrabadi, M. M., and Nasrabadi, E., "A mathematical-programming approach to fuzzy linear regression analysis", *Applied Mathematics and Computation*, 155(3), 2004, pp. 873-881.
- [14] Körner, R., "On the variance of fuzzy random variables", *Fuzzy Sets and Systems*, 92(1), 1997, pp. 83-93.
- [15] Kao, C., and Chyu, C.L. "A fuzzy linear regression model with better explanatory power", *Fuzzy Sets and Systems*, 126, 2002, pp. 401-409.
- [16] Kwong, C. K., et al., "The Hybrid Fuzzy Least-Squares Regression Approach to Modeling Manufacturing Processes", *IEEE Transactions on Fuzzy Systems*, 16, no. 3, 2008, pp. 644-651.
- [17] Watada, J., et al., "Building confidence interval based fuzzy random regression models", *IEEE Transactions on Fuzzy Systems*, 17(6), 2009, pp. 1273-1283.
- [18] Wang, H. F., and Tsaur, R. C., "Insight of a fuzzy regression model", *Fuzzy Sets and Systems*, 112(3), 2000, pp. 355-369.
- [19] Wang, H. F., and Tsaur, R. C., "Bicriteria Variable Selection in a Fuzzy Regression Equation", *Computers and mathematics with applications*, 40, 2000, pp. 877-883.
- [20] Coppi, R., et al., "Least squares estimation of a linear regression model with LR fuzzy response", *Computational Statistics & Data Analysis*, 51(1), 2006, pp. 267-286.
- [21] Durso, P., and Santoro, A., "Goodness of fit and variable selection in the fuzzy multiple linear regression", *Fuzzy Sets and Systems*, 157(19), 2006, pp. 2627-2647.

# On Simultaneous Coordination of Order Quantity and Reorder Point in a Two-Stage Supply Chain

Hung-Chi Chang

National Taichung University of Science & Technology, Taiwan  
[hungchi@nutc.edu.tw](mailto:hungchi@nutc.edu.tw)

## Abstract

*This paper revisits a recent study that addressed the effect of simultaneous coordination of order quantity and reorder point in a two-stage supply chain, where the unsatisfied demand at the retailer site is lost sales. The aim of this study is to derive the exact conditions to attain the global optimization of order quantity and reorder point for the centralized decision-making model, so as to provide a deep insight into the concerning problem. Specifically, we show that in some cases although the maximum profit of supply chain can be achieved by optimizing centralized decision, a desired improvement on customer service level may not be realized. The results are illustrated analytically and numerically.*

## 1. Introduction

Supply Chain Management (SCM) emphasizes cooperation and coordination between vendors and buyers. The importance of inventory management in SCM has been evident for a long time. The main objective of SCM is to minimize system-wide costs while satisfying service level requirements. Although the real supply chain (SC) could be very complex, in the literature, to make the analysis tractable, a simple two-stage supply chain that consists of one buyer (retailer) and one supplier (manufacturer) has been widely studied. In general, for the constant demand environment, the SC inventory/production models are formulated by extending the economic order/production quantity (EOQ/EPQ) models (see, e.g. Goyal [1], Barnejee [2], Goyal [3], Lu [4], etc). Likewise, to formulate the SC models with stochastic demand, the continuous review (lot size-reorder point) inventory systems with backorders, lost sales, or partial backorders, are often considered (see, e.g. Ben-Daya and Hariga [5], Chang et al. [6], Li and Liu [7], Sajadieh et al. [8], etc).

Recently, Chaharsooghi et al. [9] proposed the decentralized/centralized decision making models to

address the effects of simultaneous coordination of order quantity and reorder point in a two-stage SC, where they considered that the unsatisfied demand at the retailer site is lost. The main concern is: the retailer's reorder point has a direct impact on product availability and customer service level (*CSL*, which is measured by the probability of no stock out per replenishment cycle). Specifically, they concluded that their proposed coordination model assures global optimization of order quantity-reorder point decisions, which can lead to increased SC profitability as well as *CSL* improvement. However, we find that some of their results need to clarify.

In this study, we revisit the SC problems considered in [9]. Our aim is to derive the exact conditions to attain the global optimization of order quantity and reorder point for the centralized decision model. By numerical experiments, we show that in some cases when the goal of maximizing SC profit is achieved through optimizing centralized decision, a desired improvement on *CSL* may not be realized. But without insisting on the maximum profit, an appropriate centralized policy can lead to a higher SC profit and a higher *CSL* than the decentralized policy. Additionally, we show that the SC model with lost sales proposed by [9] is different from that developed by the traditional approach (Hadley and Whitin [10]), and the result obtained by the traditional approach is consistent to our finding.

## 2. A review of SC model with lost sales

In order to tract the analysis, let us briefly review the works done by [9], where the notations are defined as follows.

- $A_1$  the ordering cost per replenishment in retailer's site
- $A_2$  the ordering cost per replenishment in the supplier's site
- $h_1$  the inventory holding cost per unit per year in retailer's site
- $h_2$  the inventory holding cost per unit per year in the supplier's site

- B* the shortage cost per unit in retailer's site  
*c* the wholesale price per unit (as sold by supplier to retailer)  
*p* the retailing price per unit (as sold by retailer to customer)  
*r* the price of the product as purchased from external supplier  
*D* the total expected customer demand per year  
*Q* the retailer order quantity (as ordered by retailer to supplier; decision variable)  
*s* the retailer's reorder point (decision variable)  
 $\mu$  the expected lead time demand  
*k* the safety factor  
 $\sigma_L$  the standard deviation of demand in the lead time interval  
*SS* the safety stock  
*n* a positive integer that denotes the number of retailer's orders covered by each replenishment from supplier (decision variable)  
*E(s)* the expected shortage per replenishment cycle (function of reorder point)  
 $\bar{F}(k)$  the probability that a standard normal random variable is larger than *k*

### 2.1. Non-coordinated decentralized decision making model

For the traditional two-stage SC, [9] considered that the retailer and the supplier pursue their own profit and make decision individually. The retailer's profit, building upon the continuous review inventory system with lost sales, is formulated as

$$\Pi_b(Q, s) = (p - c)D - \frac{A_1 D}{Q + E(s)} - h_1 \left\{ \frac{Q^2}{2[Q + E(s)]} + s - \mu + E(s) \right\} - \frac{(B + p - c)DE(s)}{Q + E(s)} \quad (1)$$

For a situation where the lead-time demand follows a normal distribution, the reorder point and the expected shortage per replenishment cycle are then expressed as  $s = \mu + SS = \mu + k\sigma_L$  and

$$E(s) = \sigma_L \int_k^\infty (u - k) \frac{1}{\sqrt{2\pi}} e^{-u^2/2} du \quad \text{respectively, and}$$

the customer service level is measured by  $1 - \bar{F}(k) = 1 - \int_k^\infty \frac{1}{\sqrt{2\pi}} e^{-u^2/2} du$ . Moreover, to locate

$(Q^*, s^*)$  that maximizes  $\Pi_b(Q, s)$ , the first-order necessary condition (FONC) with respect to *Q* and *s* along with an iterative procedure is developed.

For the supplier who receives orders from the retailer in constant batches, the profit function is established as

$$\Pi_s(n) = (c - r) \left[ D - \frac{E(s)D}{Q + E(s)} \right] - \frac{A_2}{nQ} \left[ D - \frac{E(s)D}{Q + E(s)} \right] - h_2 \frac{(n-1)Q}{2} \quad (2)$$

To locate  $n^*$ , [9] first derived  $n_D$  (the optimal continuous value of *n*) by FONC, and then evaluated  $\Pi_s(n)$  for integer values around  $n_D$ .

The maximum profit of non-coordinated decentralized model is obtained by plugging the individual optimal solutions  $(Q^*, s^*)$  and  $n^*$  into (1) and (2).

$$\Pi_{chain}^{decentralized}(Q^*, s^*, n^*) = \Pi_b(Q^*, s^*) + \Pi_s(n^*) \quad (3)$$

### 2.2. Centralized decision making model

For the centralized decision model, the objective function (SC profit) is formulated by adding (1) and (2), that is,

$$\begin{aligned} \Pi_{chain}^{centralized}(Q, s, n) &= (p - r)D - h_1[s - \mu + E(s)] \\ &- \left[ A_1 + \frac{h_1 Q^2}{2D} + (B + p - r - \frac{A_2}{nQ})E(s) \right] \frac{D}{Q + E(s)} \\ &- \frac{A_2 D}{nQ} - \frac{(n-1)h_2 Q}{2} \\ &= (p - r)D - \frac{[A_1 + (A_2/n)]D}{Q + E(s)} \\ &- h_1 \left\{ \frac{Q^2}{2[Q + E(s)]} + s - \mu + E(s) \right\} \\ &- \frac{(n-1)h_2 Q}{2} - \frac{(B + p - r)E(s)D}{Q + E(s)} \quad (4) \end{aligned}$$

Likewise, for this model, [9] derived the FONC and developed an algorithm procedure to find the optimal solution  $(Q^{**}, s^{**}, n^{**})$  and the maximum profit

$$\Pi_{chain}^{centralized}(Q^{**}, s^{**}, n^{**}) = \Pi_b(Q^{**}, s^{**}) + \Pi_s(n^{**})$$

### 3. Analysis

For ease to illustrate, let us denote the cdf and pdf of standard normal random variable by  $\Phi(\cdot)$  and  $\phi(\cdot)$  respectively. Using the results

$$E(s) = \sigma_L \{\phi(k) - k[1 - \Phi(k)]\} \equiv \sigma_L \psi(k)$$

and

$$CLS = 1 - \bar{F}(k) = \Phi(k),$$

the FONC (derived by [9]) for determining the retailer's decision can be rewritten as

$$Q = \sqrt{\frac{[\sigma_L \psi(k)]^2 + \frac{2D}{h_1} [A_1 + (B + p - c)\sigma_L \psi(k)]}{- \sigma_L \psi(k)}}$$

and

$$A_1 D - (B + p - c) D Q + h_1 \left\{ \frac{Q^2}{2} + \frac{\Phi(k)}{1 - \Phi(k)} [Q + \sigma_L \psi(k)]^2 \right\} = 0 \quad (7)$$

Moreover, to find  $(Q^*, k^*)$  satisfying (6) and (7) simultaneously, we can substitute (6) into (7) and then solve the resulting equation for a single variable  $k$ . The popular software such as Goal Seek in Excel is applicable to achieve this task.

For the supplier, the optimal integer value of  $n$  can be derived easily using the marginal analysis. The result is

$$n^* = \left\lfloor \frac{1}{2} + \sqrt{\frac{2A_2 D}{h_2 Q^* [Q^* + \sigma_L \psi(k^*)] + \frac{1}{4}}} \right\rfloor, \quad (8)$$

where  $\lfloor x \rfloor$  is the largest integer  $\leq x$ . Note that there could have two optimal solutions for integer  $n$ . Here, for simplicity, we just list a single optimal solution. For more details, see e.g. Naddor [11], García-Laguna et al. [12].

On the other hand, for fixed  $n$ , it can be observed that the structure of profit function (4) is similar to that of (1). Therefore, the FONC with respect to  $Q$  and  $k$  resulting from (4) and (1) should be similar, while the formulas derived by [9] look differently. By resolving (4), we obtain

$$Q = \frac{\sqrt{h_1 [\sigma_L \psi(k)]^2 + 2D \left[ A_1 + \frac{A_2}{n} + (B + p - r)\sigma_L \psi(k) \right]}}{h_1 + h_2(n-1)} - \sigma_L \psi(k) \quad (9)$$

and

$$\left( A_1 + \frac{A_2}{n} \right) D - (B + p - r) D Q + h_1 \left\{ \frac{Q^2}{2} + \frac{\Phi(k) [Q + \sigma_L \psi(k)]^2}{1 - \Phi(k)} \right\} = 0 \quad (10)$$

which clearly are similar to (6) and (7).

To illustrate the results of above models, [9] conducted a set of numerical experiments, where they found that the centralized (coordinated) model always has higher *CSL* and lower  $E(s)$  than the non-coordinated decentralized model. The basic data used in [9] are  $D=500$ ,  $p=40$ ,  $c=36$ ,  $r=30$ ,  $A_1=50$ ,  $A_2=80$ ,  $h_1=4$ ,  $h_2=3$ ,  $\mu=60$ ,  $\sigma_L=20$ , and  $\beta=3$ . Here, for illustrative purpose, we first take  $A_2=250$  (instead of  $A_2=80$ ) and use the FONC given in [9] to find the solutions for the decentralized and centralized SC models. Table 1 shows the computing results.

**Table 1. Solutions obtained by [9]'s FONC**

Model	Decision variables			Performance criteria				
	$Q$	$s$	$k$	$E(s)$	$\Gamma$	$\Gamma$	$\Pi_{ci}$	$CSL$
decentralized SC	1	ξ	1	1	1	1	33	8
	21	2	.08	.42	424	945	68	6.0
	1	ξ	1	1	1	2	36	8
	21	2	.08	.42	424	273	97	6.0
centralized SC	1	ξ	1	1	1	2	36	8
	21	2	.08	.42	424	262	86	6.0
	2	ξ	1	1	1	2	37	8
	81	1	.06	.47	243	542	85	5.6
decentralized	1	ξ	1	0	1	2	37	9
	62	7	.34	.83	395	358	53	1.0
	1	ξ	1	0	1	2	36	9
	18	0	.50	.59	415	280	95	3.3

From Table 1, for the decentralized model, we obtain  $Q^* = 121$ ,  $s^* = 81.6$ ,  $\Pi_b = 1423.7$ ,  $E(s^*) = 1.4233$  and  $CSL = 86.03\%$  (the same as those obtained by [9]) for the retailer;  $n^* = 2$  and  $\Pi_s = 2273.2$  for the supplier. That is, using the decentralized policy yields  $\Pi_{chain}^{decentralized}(Q^*, s^*, n^*) = 3696.9$  and  $CSL = 86.03\%$ . For the centralized SC model, we obtain  $(Q^{**}, s^{**}, n^{**}) = (281, 81.3, 1)$ ,  $\Pi_{chain}^{centralized}(Q^{**}, s^{**}, n^{**}) = 3785.0$ ,  $CSL = 85.63\%$  and  $E(s^{**}) = 1.4731$ . The above results show that the optimal centralized policy leads to a lower *CSL* than the decentralized policy, which is different from [9]'s findings.

Now, we use the rectified FONC ((9) and (10)) to find the optimal solution for the centralized SC model. The computing results are listed in Table 2.

**Table 2. Solutions obtained by the rectified FONC**

Model	Decision variables			Performance criteria				
	$Q$	$s$	$k$	$E(s)$	$\Gamma$	$\Gamma$	$\Pi_c$	$CSL$
Centralized	283	78.7	0	1	1	2	37	8
Decentralized	83	9	.93	.89	245	541	86	2.5
SC	63	5	.26	.00	398	356	54	9.5
S	1	8	1	0	1	2	36	9
C	19	8	.42	.70	418	277	95	2.2

From Table 2, we obtain  $(Q^{**}, s^{**}, n^{**}) = (283, 78.7, 1)$ ,  $\Pi_{chain}^{centralized}(Q^{**}, s^{**}, n^{**}) = 3785.9$ ,  $CSL = 82.49\%$  and  $E(s^{**}) = 1.8857$ , which show that [9] overestimated the  $CSL$  and underestimated the expected shortage per replenishment cycle. The results also indicate that when the maximum profit of SC is achieved, the  $CSL$  made by the retailer is sacrificed. Additionally, it can be observed that an appropriate centralized policy can lead to a larger profit and a higher  $CSL$  than the decentralized policy. For instance, taking  $n=2$ ,  $Q=162.9$  and  $s=85.1$ , yields  $\Pi_{chain} = 3753.9$  ( $>3696.9$ ) and  $CSL = 89.52\%$  ( $>86.03\%$ ). Moreover, to achieve coordination without decreasing  $CSL$  ( $=86.03\%$ ), we can simply set  $k=1.082$  (the result of decentralized policy). Under this setting, the corresponding optimal solutions  $Q=280.8$  and  $n=1$  will yield a larger profit  $\Pi_{chain} = 3784.7$  ( $>3753.9$ ).

#### 4. Discussion

The earliest work on lost sales inventory models with a fixed order size replenishment policy dates back to Hadley and Whitin [10]. Under the assumptions where there is never more than a single order outstanding, constant lead time, and a Poisson process generates demands with units being demanded one at a time, [10] derived an exact expression for the expected total cost. Following the approach presented by [10], the retailer's profit shown in (1) should be modified as

$$\Pi_b(Q, s) = (p - c)D - \frac{A_1 D}{Q + E(s)} - h_1 \left\{ \frac{Q^2}{2[Q + E(s)]} + \frac{[s - \mu + E(s)]Q}{Q + E(s)} \right\} - \frac{(B + p - c)DE(s)}{Q + E(s)} \quad (11)$$

However, as mentioned in [10], it is unnecessary to use the exact expression (11) to determine the optimal

values of  $Q$  and  $s$ , since it is rather difficult and a simple approximate model will suffice.

For the concerning SC problem, using the approximate model proposed by [10], the retailer's profit becomes

$$\Pi_b(Q, s) = (p - c)D - \frac{A_1 D}{Q} - h_1 \left[ \frac{Q}{2} + s - \mu + E(s) \right] - \frac{(B + p - c)E(s)D}{Q} \quad (12)$$

The supplier's profit becomes

$$\Pi_s(n) = (c - r)D \left( 1 - \frac{E(s)}{Q} \right) - \frac{A_2 D}{nQ} \left( 1 - \frac{E(s)}{Q} \right) - h_2 \frac{(n-1)Q}{2} \quad (13)$$

The total profit for the centralized decision-making model becomes

$$\Pi_{chain}^{centralized}(Q, s, n) = (p - r)D - \left( A_1 + \frac{A_2}{n} \right) \frac{D}{Q} - \frac{[h_1 + h_2(n-1)]Q}{2} - h_1 [s - \mu + E(s)] - \left( B + p - r - \frac{A_2}{nQ} \right) \frac{E(s)D}{Q} \quad (14)$$

The procedures of determining the optimal solutions for the decentralized and centralized decision making models are the same as presented earlier, and hence are omitted here.

Table 3 shows the optimal solutions that maximize (12), (13), and (14) respectively, using the data described earlier. Also, we list the result of centralized SC without sacrificing  $CSL$  made by the retailer.

**Table 3. Solutions obtained by the traditional approximate approach**

Model	Decision variables			Performance criteria				
	$Q$	$s$	$k$	$E(s)$	$\Gamma$	$\Gamma$	$\Pi_c$	$CSL$
Decentralized	21	3	.17	.20	419	946	64	7.9
Centralized	21	3	.17	.20	419	277	95	7.9
SC	21	3	.17	.20	419	266	85	7.9
Centralized	283	78.7	0	1	1	2	37	8
Decentralized	82	0	.01	.65	240	542	82	4.3
SC	63	6	.30	.90	394	357	51	0.4

SC	1	1	0	1	2	36	9
	19.9	.46	.64	414	279	92	2.8
Wit	2	1	1	1	2	37	8
hout	80	.17	.20	238	543	80	7.9
sacr	1	1	1	1	2	37	8
ific-	64	.17	.20	396	354	50	7.9
ing	1	1	1	1	2	36	8
CSL	21	.17	.20	419	266	85	7.9

From Table 3, we see that using the decentralized policy yields  $Q^* = 120.8$ ,  $s^* = 83.4$ ,  $\Pi_b = 1418.5$  and  $CSL = 87.87\%$  for the retailer, and  $n^* = 2$  and  $\Pi_s = 2276.8$  for the supplier; the maximum profit is  $\Pi_{chain}^{decentralized}(Q^*, s^*, n^*) = 3695.4$ . Using the centralized policy yields  $Q^{**} = 282.2$ ,  $s^{**} = 80.1$ ,  $n^{**} = 1$ ,  $\Pi_{chain}^{centralized}(Q^{**}, s^{**}, n^{**}) = 3781.6$  and  $CSL = 84.29\%$  ( $< 87.87\%$ ). To avoid sacrificing the  $CSL$ , an applicable way is setting  $k = 1.168$  and adjusting the order quantity to  $Q = 279.9$  and the reorder point to  $s = 83.4$ , which yields  $\Pi_{chain}^{centralized} = 3780.2$  ( $> 3695.4$ ), where  $\Pi_b = 1237.6$  and  $\Pi_s = 2542.5$ . Moreover, to achieve coordination, an applicable pricing scheme is that the supplier offer a discount, at least  $0.181$  ( $= (1418.5 - 1237.6) / 1000$ ) per unit, for the retailer. That is, the wholesale price set by the supplier should be lower than  $c = 35.819$ .

## 5. Conclusion

This study analyzes the effect of simultaneous coordination of order quantity and reorder point in a two-stage supply chain. We consider the centralized/ decentralized decision-making problems addressed in Chaharsooghi et al. [9]. Using [9]'s models and the models developed by the approximate approach (Hadley and Whitin [10]), we show that pursuing the maximum profit of supply chain (SC) through centralized policy may reduce the customer service level ( $CSL$ ) made by decentralized policy. However, by relaxing the goal of maximizing SC profit the applicable centralized policy could result in a larger profit along with a higher  $CSL$  than that of decentralized policy.

## 6. References

[1] S.K. Goyal, "An integrated inventory model for a single supplier-single customer problem", *International Journal of Production Research* 15(1), 1976, pp.107-111.

[2] A. Banerjee, "On 'A quantity discount pricing model to increase vendor's profits'", *Management Science* 32, 1986, pp.1513-1517.

[3] S.K. Goyal, "A joint economic-lot-size model for purchaser and vendor: a comment", *Decision Science* 19, 1988, pp.236-241.

[4] L. Lu, "A one-vendor multi-buyer integrated inventory model", *European Journal of Operational Research* 81, 1995, pp.312-323.

[5] M. Ben-Daya, and M. Hariga, "Integrated single vendor single buyer model with stochastic demand and variable lead time", *International Journal of Production Economics* 92, 2004, pp.75-80.

[6] H.C. Chang, L.Y. Ouyang, K.S. Wu, and C.H. Ho, "Integrated vendor-buyer cooperative inventory models with controllable lead time and ordering cost reduction", *European Journal of Operational Research* 170(2), 2006, pp.481-495.

[7] J. Li, and L. Liu, "Supply chain coordination with quantity discount policy", *International Journal of Production Economics* 101, 2006, pp.89-98.

[8] M.S. Sajadieh, M.R.A. Jokar, and M. Modarres, "Developing a coordinated vendor-buyer model in two-stage supply chains with stochastic lead-times", *Computers & Operations Research* 36(8), 2009, pp.2484-2489.

[9] S.K. Chaharsooghi, J. Heydari, and I.N. Kamalabadi, "Simultaneous coordination of order quantity and reorder point in a two-stage supply chain", *Computers & Operations Research* 38, 2011, pp.1667-1677.

[10] G. Hadley, and T.M. Whitin, *Analysis of inventory systems*, Englewood Cliffs: Prentice-Hall, 1963.

[11] E. Naddor, *Inventory Systems*, New York: John Wiley and Sons, 1966.

[12] J. García-Laguna, L.A. San-José, L.E. Cárdenas-Barrón, and J. Sicilia, "The integrality of the lot size in the basic EOQ and EPQ models: Applications to other production-inventory models", *Applied Mathematics and Computation* 216(5), 2010, pp.1660-1672.

## 7. Acknowledgements

This research is supported by the National Science Council of Taiwan under Grant NSC 101-2410-H-025-007.



# Quality Function Deployment for International Business Teaching Performance Evaluations

Chie-Bein Chen, Chin-Tsai Lin, Jung-Ho Lu, Yuan-Du Hsiao and Yun-Ching Wang

Department of International Business, National Dong Hwa University<sup>1</sup>  
No. 1, Sec. 2 Da-hsueh Rd., Shou-feng, Hualien, 974, Taiwan, R. O. C.  
[cbchen@mail.ndhu.edu.tw](mailto:cbchen@mail.ndhu.edu.tw)

Graduate School of Management, Ming Chuan University<sup>2</sup>  
No. 250, Chung Shan N. Rd., Sec. 5, Taipei, 111, Taiwan, R. O. C.  
[ctlin@mail.ypu.edu.tw](mailto:ctlin@mail.ypu.edu.tw)

Department of Risk Management and Insurance, Ming Chuan University<sup>3</sup>  
No. 250, Chung Shan N. Rd., Sec. 5, Taipei, 111, Taiwan, R. O. C.  
[lulu2008@gmail.com](mailto:lulu2008@gmail.com)

Department of Business Administration, Chungyu Institute of Technology<sup>4</sup>  
No. 40, Yi 7 Rd., Keelung, Taiwan, R. O. C.  
[yuduhsiao4471@yahoo.com.tw](mailto:yuduhsiao4471@yahoo.com.tw)

Department of International Business, National Dong Hwa University<sup>5</sup>  
No. 1, Sec. 2 Da-hsueh Rd., Shou-feng, Hualien, 974, Taiwan, R. O. C.  
[m9933016@ems.ndhu.edu.tw](mailto:m9933016@ems.ndhu.edu.tw)

## Abstract

*Quality function deployment (QFD) is a technique that can be used for process and design improvement. A quality improvement method can effectively enhance organizational performance. This study uses QFD to improve teaching. QFD helps professors examine how well students achieve departmental objectives. This study demonstrates how QFD methods can be used to improve teaching effectiveness.*

*Assessment of a course can determine how well course objectives are achieved. Numerous studies have explored various methods of assessing teaching and learning performance. This study uses a pair-wise comparison of an analytical hierarchy process (AHP) and QFD to build a teaching-assessment system. This system measures the achievement of learning objectives in specific courses, allowing professors to identify appropriate methods of improving their teaching quality.*

**Keywords:** *International Business, quality function deployment, analytical hierarchy process, teaching assessment*

## 1. Introduction

Educational improvement is an important issue for governments and schools. The number of universities

has rapidly increased in reaction to social environment demands. This has resulted in the higher education market approaching saturation. According to the Taiwanese Ministry of Education, the number of higher education institutions was 163 in 2011. To distinguish themselves from other universities, all universities attempt to improve their departmental course design to meet market requirements, and enable their students to better compete with their peers after graduation.

Assessment is necessary for evaluating professors to improve teaching quality. Felder and Brent [13] stated that assessment involves the selection and implementation of methods to determine whether and how well objectives are achieved, and the interpretation of these results. Assessment affects course quality, and determines the level of course objective achievement. Professors can use assessment results to identify necessary actions to improve learning and teaching performance.

This study uses a pair-wise comparison of the analytic hierarchy process (AHP) and quality function deployment (QFD) to establish the relationship between student learning outcomes and teaching. The pair-wise comparison of the AHP determines learning outcome weightings from a student perspective. QFD develops matrices to determine whether teaching meets

student expectations. The research problems are described as follows:

(a) From a student perspective, define the importance of each learning-outcome element for the department to achieve educational objectives.

(b) From a professor perspective, evaluate the expected impact of the course based on departmental objectives.

(c) From a student perspective, evaluate the actual impact of the course on departmental objectives.

(d) Examine the gap between professor expectations and student learning to identify suitable actions to improve teaching quality, and decrease this gap.

Numerous researchers have studied the skills and competencies required for an organization to succeed in a global environment. Gladstein [20] studied over 100 sales teams in the telecommunications industry to identify the skills required for excellent performance. The findings included the necessity of (a) appreciating differences in cultural perspectives, (b) leveraging diversity and conflicts to optimize team performance, (c) enhancing decision-making skills for complex environments, and (d) facilitating skills to lead teams in various locations. Bok [5] introduced the concept of education objectives. He suggested that the eight learning goals are communication skills, critical thinking, moral reasoning, citizenship, diversity,

globalization, wide ranging interests, and career preparation. The purpose of university education is to build skills in several professions, and produce students that meet future company requirements.

The following seven basic learning outcomes were developed based on the literature, and modified by professors in the study department:

(a) Students should have advanced knowledge of international business.

(b) Students should identify, analyze, and solve business problems using logical and critical thinking.

(c) Students should demonstrate effective leadership, communication, coordination, and teamwork skills.

(d) Students should communicate in foreign languages, and be aware of global and culturally diverse issues.

(e) Students should demonstrate advanced managerial skills for international business.

(f) Students should demonstrate proficiency in using advanced information technology.

(g) Students should identify and understand the importance of ethical decision making in international business.

Table 1 shows the literature relevant to the seven basic outcomes.

Table 1. Literature relevant to the seven basic outcomes

Students will have advanced knowledge in international business.	Bok [5].
Students will be able to identify, analyze and solve business problems by terms of logical and critical thinking.	Fitzgerald [16], Lighthall and Haycock [27], Rothenberg [37].
Students will be able to demonstrate effective leadership, communication, coordination and teamwork skills.	Butler [8], Butler <i>et al.</i> , [9], Fischer [15], Rummel and Spada [38].
Students will be able to communicate in foreign languages and have an awareness of global and cultural diversity issues.	Charles [10], Charlesworth [11], Friedman [18], Seidlhofer [39], Seidlhofer [40].
Students will be able to demonstrate the advanced managerial skills for international business.	Bloom and Van Reenen [3], Bruhn <i>et al.</i> , [7], Sonobe and Otsuka [42], Sonobe and Otsuka [41], Syverson [45].
Students will be able to demonstrate proficiency by utilizing advanced information technology.	Howard <i>et al.</i> , [24], Lin [28], Melville <i>et al.</i> , [33], Ravichandran and Lertwongsatien [36], Wind and Mahajan [47].
Students will be able to identify and understand the importance of ethical decision making for international business.	Frederick <i>et al.</i> , [17], Ghoshal [19], Kochan [26], Luthans <i>et al.</i> , [29], McDonald [32], Pfeffer [35], Swanson and Frederick [44], Shawver and Sennetti [41].

The AHP is a powerful and comprehensive methodology designed to facilitate decision making using empirical data and the subjective judgment of the decision maker. The AHP is a structured technique for organizing and analyzing complex decisions. It is used on mathematics and psychology, and was developed by Saaty in the 1970s. It has been extensively studied and refined since then.

The AHP can be used to calculate variable weights. Respondents evaluate variables by comparing them to each other one at a time, with respect to their impact on an element. These pair-wise comparisons identify the importance of each element. This study uses a pair-wise comparison matrix to calculate variable weights.

QFD is a systematic method of analyzing customer requirements, and applying them to product,

service, and business operations. Akao [1] developed QFD. He was the chairman of the QFD Research Committee of Japan Society, which was responsible for quality control in the early 1970s. The committee disbanded in 1987 because it successfully completed QFD promotion in Japan.

Educational pioneers in the US introduced QFD to education. Bobbitt thought that the curriculum was a method of preparing students for their roles in a new industrial society. Brackin and Rogers [6] used QFD to improve engineering and engineering education processes. They integrated customer voices into manufacturing, informing everyone in a company which characteristics customers require. Mazur [31] used QFD in training course design. Mahesh and Houshmand [30] used QFD to balance teaching and research. Hwang and Teo [25] indicated

that QFD is a powerful quality tool used in the industry. QFD can also be applied to a service environment, such as higher education.

Research from 2002 to 2012 applied these techniques to the manufacturing, tourism, logistics,

and sports sectors. Combining the AHP and QFD is one of the most commonly used techniques to manage incomplete and imprecise customer requirement information. Table 2 shows studies that have combined the techniques

Table 2. Literature that integrates QFD and AHPs

Author	Applications
Partovi <i>et al.</i> , [34]	Using QFD and AHP for prioritizing and designing rule changes for the game of soccer in order to make it more attractive to soccer enthusiasts. A trend extrapolation forecasting technique is used to suggest rule change specifications. The model fine-tunes and added precision to the otherwise ad hoc process concerning the improvement of the game of soccer, which provides insight about improvements in other professional sports.

Hanumaiah <i>et al.</i> , [21]	Using QFD-AHP methodology for rapid tooling process in selection and prioritization of process parameters. It develops a comprehensive system for a rapid tooling process selection and manufacturability evaluation. Using the QFD-AHP process selection methodology, prior to detailed manufacturability analysis, can better realize the benefits of rapid tooling technologies.
Bhattacharya <i>et al.</i> , [4]	Using a combined AHP/QFD model to determine if the deployment of robots in industry helped in performance enhancement from required perspective. An integrated model combining with AHP and QFD has been delineated for the industrial robot selection problem.
Andronikidis <i>et al.</i> , [2]	Applying QFD along with AHP and ANP within the bank sector. Through completing the house of quality to prioritize customers' bank selection criteria. It develops the integrated QFD-AHP-ANP method to design the high quality services in various services.
Das and Mukherjee [12]	The author develops an AHP-QFD framework for designing a tourism product, which takes care of the touristic needs. Identified the needs of tourists with reference to a tourist destination, the needs are prioritized with the help of the AHP, then they use QFD to formulate operating strategies by eliciting opinions from tourism professionals. Finally, the strategies are prioritized and enabled the design of a tourism product incorporated the diverse needs of tourists.
Ho <i>et al.</i> , [22]	Develop an integrated approach, combine QFD and AHP to evaluate and select the optimal third-party logistics service providers (3PLs).
De Felice and Petrillo [14]	Use QFD-AHP to define customer specifications. Author uses a model based on QFD incorporated the AHP approach to delineate and rank the relative importance weight of expressed judgments for customer needs and functional characteristics. Then author



	uses a real case study concerning the filter in ceramic material production.
Tu <i>et al.</i> , [46]	Use QFD and AHP to build a user-centered new product development process. Authors use QFD to translate the users' requirements into technical requirements and use AHP to quantify the user requirements, relate those elements to overall customer satisfaction goal and evaluate different design alternatives. Then they illustrated the design of a new sports earphone as a case study.
Ho <i>et al.</i> , [23]	To develop an integrated analytical approach, combining QFD and AHP to enhance the effectiveness of source decisions. Author applied the model to a UK-based automobile manufacturing company. QFD is to evaluate factors related to the strategic intent of the company through the involvement of concerned stakeholders. And AHP ensures consistent supplier performance measurement using benchmarking approach.

## 2. Research Methodology

Step 1: Collect customer requirement data using a questionnaire.

The first step is using a questionnaire to identify customer requirements. The questionnaire provides the data to analyze the importance of each objective element. The outcomes are used in the next step for AHP analysis.

Step 2: Use Expert Choice 2000 to calculate the importance weighting of elements. Expert Choice 2000 is AHP software that calculates these weights. The outcomes of this step are used in the QFD

model.

Step 3: Define the "whats" and "hows" of QFD. This study identifies how to achieve the objectives of the Department of International Business at D University. Thus, the whats are the basic learning outcomes. After defining the objectives, the relationship between the course and the seven basic learning outcomes is determined. Therefore, the basic learning outcomes are the whats and the courses are the hows. Figure 1 shows the basic learning outcomes and the courses.

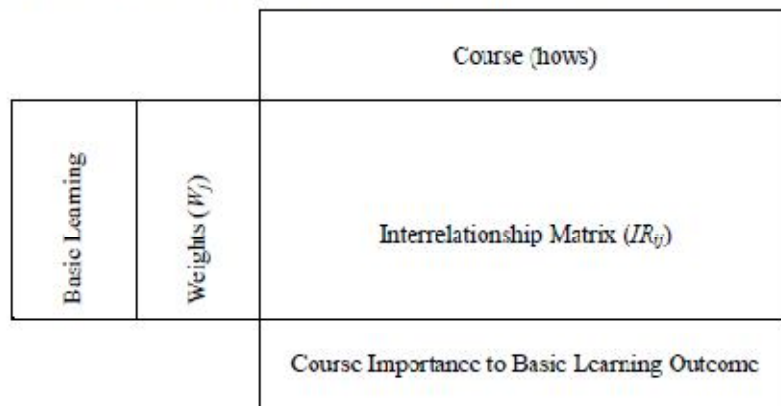


Figure 1.

course importance and basic learning outcomes

QFD of

Step 4: Define the importance weighting for the whats. Row 2 of Fig. 2 shows the importance weightings for the whats. The sum of the importance weightings is 1. The data are derived from the AHP analysis outcomes.

$$\sum_{i=1}^m W_i = 1, \quad (1)$$

Step 5: Define the relationship ( $IR_{ij}$ ) between the whats and hows from a professor perspective where

- represents a high correlation,
- represents a moderate correlation, and
- ▽ represents a low correlation.

The matrix represents the strength of the relationships between the basic learning outcomes and courses from a professor perspective.

Step 6: Calculate expected learning outcomes by determining how a professor expects a course to support faculty objectives. In Fig. 2, the information in the matrix represents the point score,  $S_{ij}$ , for each what and how intersection. These point scores are calculated by multiplying the relative importance of the whats by the strength of their interrelatedness,  $IR_{ij}$ . Data from Step 5 are used in a traditional 9-3-1 QFD scoring method where 9 represents a high correlation between an objective and outcome, 3 represents a moderate correlation, and 1 represents a low correlation. QFD capture software is then used to calculate the importance of the whats. The following equation is used to complete this process:

$$T_i = S_{ij} * W_j \quad (2)$$

Step 7: Calculate the actual learning outcomes by determining what students think they actually learn from the course. The process in Step 6 is used to calculate the level of learning performance. Students complete the matrix after participating in and finishing the course.

Step 8: Calculate teaching performance, and improve the course. Compare professor expectations and student learning to identify the differences

between professor and student opinions. Based on the results, professors can identify suitable actions to improve course quality and meet course objectives.

### 3. Case Implementation

The first semester of 2012 in the Department of IB at D University was used as a case study. During this semester, the department offered three required courses and five optional courses for master's students.

#### 3.1 Pair-wise Comparison of the AHP

Student requirement data was collected using questionnaires. Participants were recruited from master's students in the International Business Department at D University. Of the 42 distributed questionnaires, 35 were completed (83.3%). The sample consisted of 43% second-year graduate students and 57% first-year graduate students. Expert Choice 2000 was used to calculate the importance weighting of elements. The results are shown in Figure 2.

The results show that the most important learning outcome is coordination and teamwork, with a weight of 0.223. The second most important outcome is communication in foreign languages with a weight of 0.188, followed by logical and critical thinking with a weight of 0.186. A consistency index of 0.01 indicates that the inconsistency of the matrix is acceptable.

#### 3.2 QFD Analysis

To assess teaching performance, opinions were collected from professors and students. Professors were asked how the course is intended to meet departmental learning outcomes. Students were asked if the course achieved these objectives after completing the course.



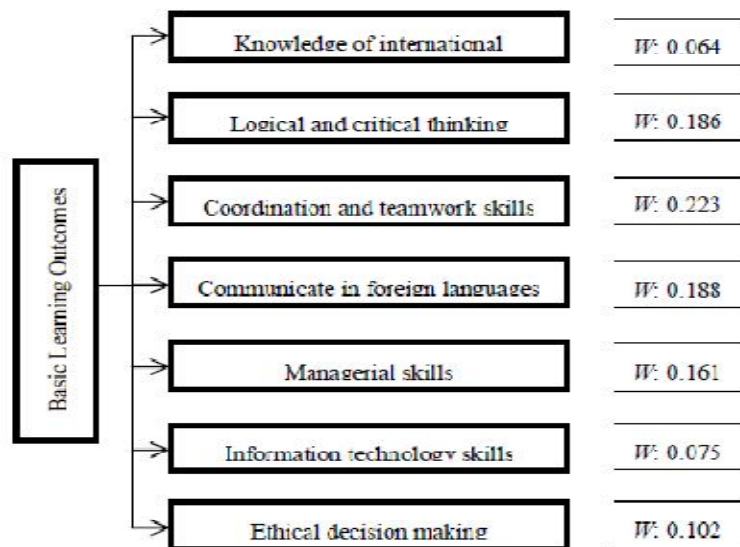


Figure 2. Importance weighting of each objective

Professor opinion data were collected from the course outline that professors send to students at the beginning of semester. Student opinion data were collected from the questionnaires sent to students at the end of semester.

Figure 3 shows the importance of learning outcomes from professor opinions. Column 1 is derived from AHP analysis. Column 2 represents the figures in Column 1 as percentages. The "Importance of the hows" row is derived from the interrelation multiplied by Column 2. For instance, the course International Business Management has a how importance of 855. This is derived from  $9 * 6.4 + 9 * 18.6 + 9 * 22.3 + 9 * 18.8 + 9 * 16.1 + 3 * 7.5 + 9 * 10.2 = 855$ . The row, "Percentage importance of the hows" represents the figures in the "Importance of the hows" column as percentages.

These results are from professor opinions. The impact of International Business Management on desired outcomes is 15. This indicates that International Business Management accounts for 15

% of educational objective achievements. Therefore, the most important course for achieving learning outcomes in that semester was is International Business Management.

Figure 4 shows the level of course objective achievement based on student opinions. The impact of International Business Management on desired outcomes is 14.9. This indicates that students feel that International Business Management accounts for 14.9% of educational objective achievement.

### 3. Comparison of Professor Expectations and Student Learning Outcomes

After calculating the QFD of professor expectations and students' actual learning, these results were compared to assess teaching performance. Table 3 shows a comparison of professor expectations and student evaluations. If student learning exceeds professor expectations, a positive gap exists in the table. If professor



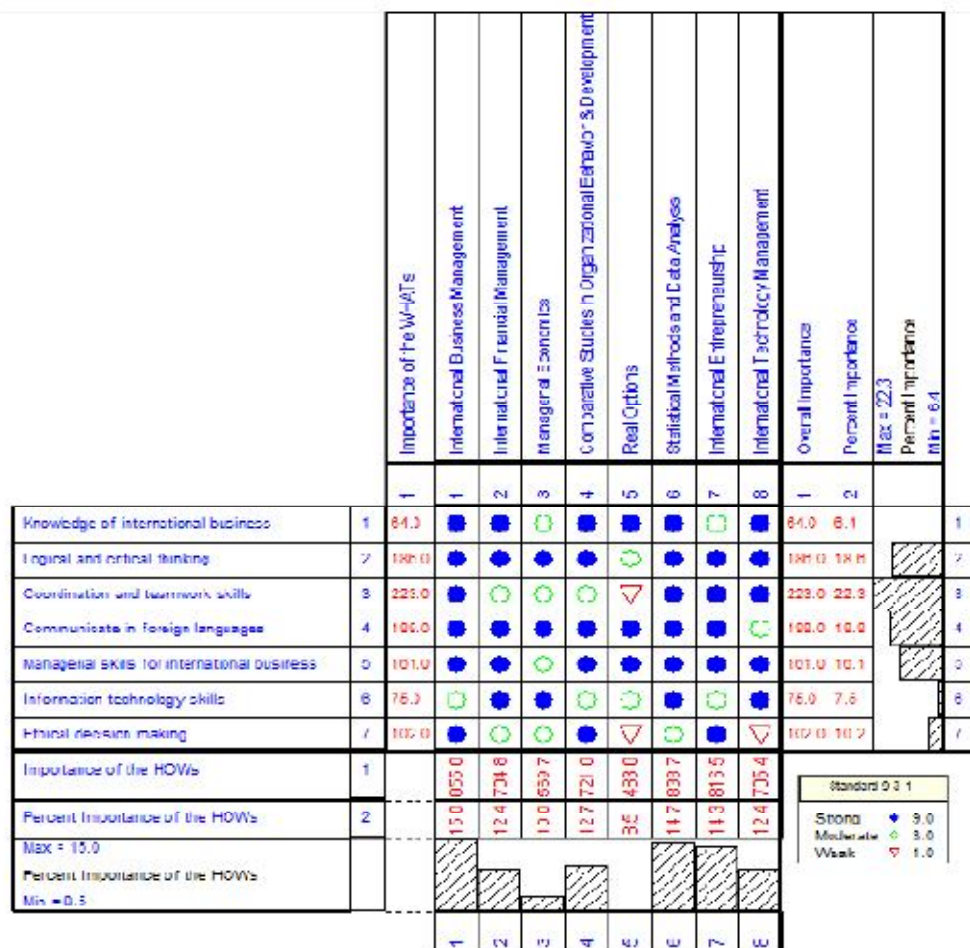


Figure 3. Quality of first semester courses in 2012, and learning outcomes based on professor opinions

expectations exceed student learning, a negative gap exists between teaching and learning, indicating that professors should improve their teaching to eliminate this gap.

International Business Management shows a gap of -0.1%, International Financial Management shows a gap of -1.3%, Comparative Study in Organizational Behavior and Development shows a gap of 2.7%, Statistical Methods and Data Analysis shows a gap of -0.8%, and International Entrepreneurship shows a gap of -2.5%. Comparative

Studies in Organizational Behavior and Development, International Entrepreneurship, and International Financial Management show the three largest gaps.

### 3.4 Course Improvements

Table 3 shows that professors of Comparative Studies in Organizational Behavior and Development, International Entrepreneurship, and International Financial Management should change their teaching methods to allow student learning to meet their expectations. The suggestions of this study are

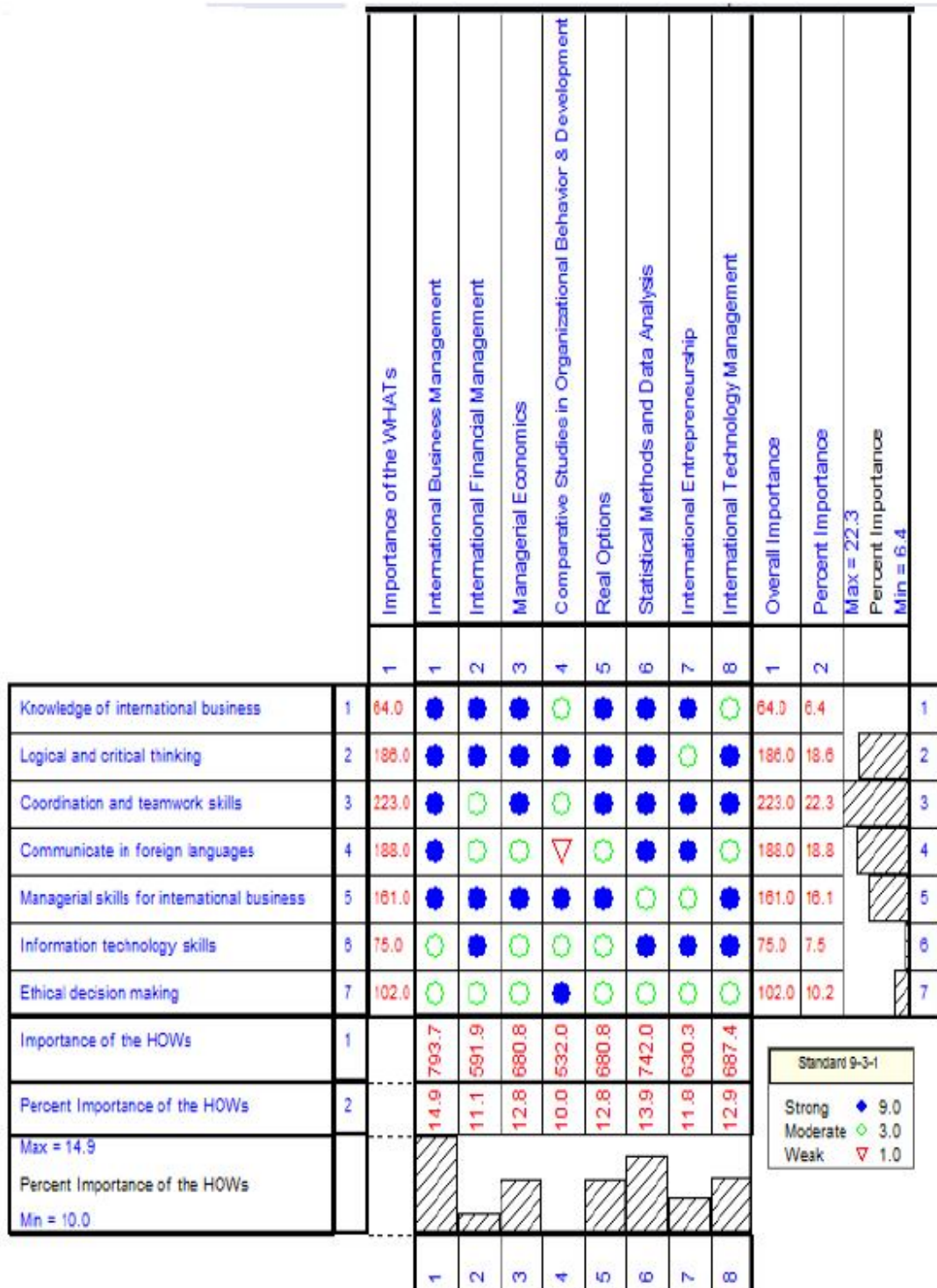


Figure 4. Quality of first semester courses in 2012, and learning outcomes based on student opinions

Table 3. Comparison between professor expectations and student evaluations

	Professors expect the course to contribute to their objectives (%)	Students evaluate what they learn from the course (%)	Gap
International Business Management	15.0	14.9	-0.1
International Financial Management	12.4	11.1	-1.3
Managerial Economics	10.0	12.8	2.8
Comparative Studies in Organizational Behavior & Development	12.7	10.0	-2.7
Real Options	8.5	12.8	4.3
Statistical Methods and Data Analysis	14.7	13.9	0.8
International Entrepreneurship	14.3	11.8	-2.5
International Technology Management	12.1	12.9	0.8

summarized as follows:

- (a) For Comparative Studies in Organizational Behavior and Development a comparison between professor expectations and student questionnaires shows that communication in foreign languages has been evaluated differently. Professors should emphasize this objective. Professors could add more English tests or allow students to present case studies in English.
- (b) For International Entrepreneurship, based on student opinions, the course did not sufficiently support logical and critical thinking, managerial skills for international business, and ethical decision making. Professors can improve the course by focusing on these objectives by discussing the importance of ethics and teaching more managerial and logic skills in class.
- (c) For International Financial Management, students and professors evaluated communication in foreign languages differently. Professors could incorporate more English tests and oral presentations into the curriculum.

## 4. Conclusion and Recommendations for Future Research

### 4.1 Conclusion

When schools assess teaching performance, they typically ignore the level of achievement of individual learning objectives. This study provides an assessment method to measure the level of learning objective achievement. This assessment method uses QFD, a quality control tool, to assess teaching and learning quality. The study measures professor expectations and student performance to compare the differences between expectations and reality. The results of this study are summarized as follows:

- (a) Student and professor expectations should be considered when assessing performance.
- (b) Individual objectives can be measured. Assessment of individual objectives identifies which objectives require the most improvement.
- (c) The assessment method can be used to measure learning and teaching performance. This method



does not only apply to international business departments but can be used by other faculties.

#### 4.2 Recommendations for Future Research

Future research should continue to monitor student learning performance after professors improve their teaching quality, based on the results of this assessment method. Quality control is a continuous process that can be used to improve quality iteratively. Time restricted this study; therefore, it could not evaluate the effects of the assessment method. If time was not a constraint, three or four continuous semesters of the same course should be studied to examine whether teaching quality improved.

#### References

- [1] Y. Akao, QFD: Past, Present, and Future, International Symposium on QFD '97, 1997.
- [2] A. Andronikidis, A. C. Georgiou, K. Gotzamani and K. Kamvysi, "The Application of Quality Function Deployment in Service Quality Management," *The TQM Journal*, Vol. 21, 2008, pp. 319-333.
- [3] N. Bloom and J. Van Reenen, "Measuring and Explaining Management Practices across Firms and Countries," *Quarterly Journal of Economics*, Vol. 122, 2007, pp. 1351-1408.
- [4] A. Bhattacharyay, B. Sarkar and S. K. Mukherjee, "Integrating AHP with QFD for Robot Selection under Requirement Perspective," *International Journal of Production Research*, Vol. 43, 2005, pp. 3671-3685.
- [5] D. Bok, *Our Underachieving Colleges*, 2006 Princeton University Press.
- [6] P. Brackin and G. M. Rogers, "Assessment and Quality Improvement Process in Engineering and Engineering Education," *The 29th ASEE/IEEE Frontiers in Education Conference*, Vol. 11, 1999, pp. 1-21.
- [7] M. Bruhn, D. Karlan and A. Schoar, "What Capital is Missing in Developing Countries," *American Economic Review: Papers and Proceedings*, Vol. 100, No. 2, 2010, pp. 629-33.
- [8] C. Butler, "The Soft Side of the M. B. A.," *U. S. News & World Report*, Vol. 142, 2007, pp. 74-78.
- [9] D. Butler, F. Benjamin and L. Johnson, "An Examination of Skills Based Leadership Coaching Course in an MBA Program," *Journal of Education for Business*, Vol. 83, 2008, pp. 227-232.
- [10] M. Charles, "Language Matters in Global Communication," *Journal of Business Communication*, Vol. 44, 2007, pp. 260-282.
- [11] Z. Charlesworth, "Educating International Hospitality Students and Managers: the Role of Culture," *International Journal of Contemporary Hospitality Management*, Vol. 19, 2007, pp. 133-45.
- [12] D. Das and K. Mukherjee, "Development of an AHP-QFD Framework for Designing a Tourism Product," *International Journal of Services and Operations Management*, Vol. 4, 2008, pp. 321-344.
- [13] M. R. Felder and R. Brent, "Designing and Teaching Courses to Satisfy the ABET Engineering Criteria," *ASEE Journal of Engineering Education*, Vol. 92, 2003, 7-25.
- [14] F. De Felice and A. Petrillo, "A Multiple Choice Decision Analysis: An Integrated QFD-AHP Model for the Assessment of Customer Needs," *International Journal of Engineering, Science and Technology*, Vol. 2, 2010, pp. 25-38.
- [15] G. Fischer, "Distances and Diversity: Sources for Social Creativity," in *Proceedings of the 5th Conference on Creativity & Cognition*, Vol. 12, 2005, pp. 128-136.
- [16] M. A. Fitzgerald, "Skills for Evaluating Web-based Information," *Internet Credibility Symposium*, University of Washington, Seattle, 2005.
- [17] W. C. Frederick, K. Davis. and J. E. Post, *Business and Society: Corporate Strategy, Public Policy and Ethics*, New York, NY: McGraw Hill, 1988.
- [18] T. L. Friedman, *The World is Flat*, New York. NY: Basic Books, 2006.
- [19] S. Ghoshal, "Bad Management Theories are Destroying Good Management Practices," *The Academy of Management Learning and Education*, Vol. 4, 2005, pp. 75-91.

- [20] D. Gladstein, "Groups in Context: A Model of Task Group Effectiveness," *Administrative Science Quarterly*, Vol. 29, 1984, pp. 499-517.
- [21] N. Hanumaiah, B. Ravi and N. P. Mukherjee, "Rapid Hard Tooling Process Selection Using QFD-AHP Methodology," *Journal of Manufacturing Technology Management*, Vol. 17, 2004, pp. 332-350.
- [22] W. Ho, T. He, C. Lee and A. Emrouznejad, "Strategic Logistics Outsourcing: An Integrated QFD and Fuzzy AHP Approach," *Industrial Engineering and Engineering Management*, Vol. 11, 2009, pp. 1434-1438.
- [23] W. Ho, P. K. Dey and M. Lockström, "Strategic Sourcing: a Combined QFD and AHP Approach in Manufacturing," *Supply Chain Management: An International Journal*, Vol. 16, 2011, pp. 446-461.
- [24] M. Howard, R. Vidgen and P. Powell, "Overcoming Stakeholder Barriers in the Automotive Industry: Building to Order with Extra-organizational Systems," *Journal of Information Technology*, Vol. 18, 2003, pp. 27-43.
- [25] H. B. Hwang and C. Teo, "Applying QFD in Higher Education," *ASQ, Annual Quality Congress Proceedings*, Indianapolis, Vol. 54, 2000, pp. 255-263.
- [26] T. A. Kochan, "Addressing the Crisis in Confidence in Corporations: Root Causes, Victims and Strategies for Reform," *Academy of Management Executive*, Vol. 16, 2002, pp. 139-141.
- [27] L. Lighthall and K. Haycock, *Information Rich but Knowledge Poor? Emerging Issues for Schools and Libraries Worldwide*, International Association of School Librarianship, 1997.
- [28] L. H. Lin, "Electronic Human Resource Management and Organizational Innovation: The Roles of Information Technology and Virtual Organizational Structure," *The International Journal of Human Resource Management*, Vol. 22, 2011, pp. 235-257.
- [29] F. Luthans, R. M. Hodgetts and K. R. Thompson, *Social Issues in Business*. New York, NY: Macmillan, 1984.
- [30] K. Mahesh and A. Houshmand, "QFD in Academia: Addressing Customer Requirements in the Design of Engineering Curricula," *Symposium on Quality Function Deployment*, Novi, Michigan. Ann Arbor, MI: QFD Institute, 1993, pp. 505-530.
- [31] G. H. Mazur, "The Future of TQM: A North American Perspective," *Japanese Society for Quality Control*, Hinshitsu, Vol. 26, 1996, pp. 10-19.
- [32] G. M. McDonald, "A Case Example: Integrating Ethics into the Academic Business Curriculum," *Journal of Business Ethics*, Vol. 54, 2005, pp. 371-384.
- [33] N. Melville, K. Kraemer and V. Gurbaxani, "Information Technology and Organizational Performance: An Integrative Model of IT Business Value," *MIS Quarterly*, Vol. 28, 2004, pp. 283-322.
- [34] F. Y. Partovi and R. A. Corredoira, "Quality Function Deployment for the Good of Soccer," *European Journal of Operational Research*, Vol. 137, 2002, pp. 642-656.
- [35] J. Pfeffer, "Why Do Bad Management Theories Persist?" A comment on *Ghoshal Academy of Management Learning and Education*, Vol. 4, 2005, pp. 101-103.
- [36] T. Ravichandran and C. Lertwongsatien, "Effect of Information System Resources and Capabilities on Firm Performance: A Resource-based Perspective," *Journal of Management Information Systems*, Vol. 21, No. 4, 2005 pp. 237-276.
- [37] D. Rothenberg, *How the Web Destroys the Quality of Students' Research Papers*, The Chronicle of Higher Education, Inc., 1997.
- [38] N. Rummel and H. Spada, "Learning to Collaborate: An Instructional Approach to Promoting Problem-solving in Computer-mediated Settings," *The Journal of the Learning Sciences*, Vol. 14, 2005, pp. 201-241.
- [39] B. Seidlhofer, "Closing a Conceptual gap: The Case for a Description of English as a Lingua Franca," *International Journal of Applied Linguistics*, Vol. 11, No. 2, 2001, pp. 133-158.
- [40] B. Seidlhofer, "Research Perspectives on Teaching English as a Lingua Franca," *Annual Review of Applied Linguistics*, Vol. 24, 2004, pp. 209-239.
- [41] T. J. Shawver and J. T. Sennetti, "Measuring Ethical Sensitivity and Evaluation," *Journal of Business Ethics*, Vol. 88, 2009, pp. 663-678.

[42] T. Sonobe and K. Otsuka, *Cluster-based Industrial Development: An East Asian Model*, Basingstoke: Palgrave Macmillan, 2006.

[43] T. Sonobe and K. Otsuka, *Cluster-based Industrial Development: A Comparative Study of Asia and Africa*, Basingstoke: Palgrave Macmillan, 2010.

[44] D. L. Swanson and W. C. Frederick, "Denial and Leadership in Business Ethics Education," in Peterson, R. and Ferrell, O. *Business Ethics: The New Challenge for Business Schools and Corporate Leaders*, New York: M. E. Sharpe, 2005, pp. 222-240.

[45] C. Syverson, "What Determines Productivity?" *Journal of Economic Literature*, Vol. 49, No. 2, 2011, pp. 326-365.

[46] N. Tu, T. Zhang, Q. He, H. Zhang and Y. Li, "User-centered Design in New Product Development: A Case Study in Developing New Sports Earphone," *Computer and Management (CAMAN)*, Vol. 21, 2011, pp. 1-7.

[47] J. Wind and V. Mahajan, "Issues and Opportunities in New Product Development: An Introduction to the Special Issue," *Journal of Marketing Research*, Vol. 34, No. 1, 1977, pp. 1-12.

# Selecting the Optimal Brand TV Commercial Script for a Real Estate Agency Using Grey Relational Analysis

Pi-Fang Hsu<sup>1</sup>, Hung-yu Chueh<sup>2</sup>

*Department of Communications Management, Shih Hsin University, Taipei, Taiwan*<sup>1,2</sup>  
E-mail: [pfhsu@cc.shu.edu.tw](mailto:pfhsu@cc.shu.edu.tw)<sup>1</sup>, E-mail: [hungyu.chueh@gmail.com](mailto:hungyu.chueh@gmail.com)<sup>2</sup>

## Abstract

*This study develops a model to aid businesses' selection of TV commercial scripts using the example of a real estate agency. First, the modified Delphi method is adopted in the proposed model to determine the suitable evaluative criteria for selecting the script. Next the grey relational analysis (GRA) is employed to rank the alternatives and select the optimal script.*

*The example of a famous real estate agency in Taiwan is used to show how TV commercial scripts can be selected using this model. The results address factors such as application of communication messages, how advertising appeals and gains consumer acceptance, how it renders consumers' needs, its effects, and the script's content that are the most vital criteria in the selection of brand TV commercial scripts. The proposed model helps the real estate agency to effectively select TV commercial scripts, making it highly applicable for both academia and commerce.*

## 1. Introduction

After more than 20 years of operation in Taiwan, a real estate agency that started their business by direct sales with turnover in the tens of millions, found itself in need of an advertising campaign. It wished to raise consumer awareness of its brand, so that people would consider not only their service and product quality but also assign value to the brand itself. According to this new strategy, brand management would no longer depend solely on direct sales, and achieving such a transition will require a complete brand advertising overhaul.

As a real estate agency's business model is typically "direct and join," it will require diversification and enterprise management to increase rather than simply maintain brand awareness. This can be achieved through advertising of their brand to catch

consumers' attention, and a well-chosen advertising campaign offers the possibility to drive product sales by placing the brand at the top of consumers' minds to increase their likelihood of purchasing the products. A successful campaign will examine a variety of media, looking for the best consumer contact point, to ensure that every piece of marketing achieves the highest efficiency.

In this technological world, everything moves faster than in the past and media outlets and forms have grown exponentially. As a whole, media has increasingly high penetration rates, but TV's media penetration rate has dropped from more than 95% to 91%, largely because internet and mobile media have encroached on TV's typical audiences. However, according to Nielsen Audience Measurement, TV remains the most effective media for promoting an enterprise's brand or product [26]. To attract maximum viewer attention, a TV commercial should be "dynamic" with audio and video, accompanied by a voice-over to present the product. These elements should work together to create a three-dimensional expression of the brand that captures consumers' interest [21]. Different types of advertising have different roles. Considering all the different possible advertising situations, we can identify nine major types of advertising to boost consumer awareness: brand advertising, retail or local advertising, instruction advertising, political advertising, business-to-business advertising, institutional advertising (corporate), and direct-response or interactive advertising [19].

When enterprises want to gain visibility in the short term, the fastest way is through the TV media, with a penetration rate of more than 90%, to reach as many consumers possible. However, a TV commercial's media fee and production costs are two or three times higher than other media types. Despite this drawback, a TV commercial can be the most important piece of a marketing strategy. Therefore, to ensure the optimal



allocation of the media budget, the content of an enterprise's TV commercial should be well-grounded in the principles of advertising effectiveness.

Brand advertising is the most effective brand communication foundation for creating or enhancing a brand, across all types of advertising [10]. Therefore, selecting a brand TV commercial script is a multi-criteria, decision-making (MCDM) problem, with enterprises selecting a TV commercial script named by the advertising company and marketing department for discussion, but senior managers remain the final decision-making group. As a result, the final product is often too strongly influenced by an enterprise's managers and thus may lack an objective perspective.

This study develops a model for a brand to select the optimum TV commercial script. A real estate agency is used a case study to showcase the model. First, the modified Delphi method is adopted in the model and the decision-making group solicits anonymous expert advice to identify suitable evaluative criteria. Next, gray relational analysis is applied to rank the alternatives and select the optimum TV commercial script. This study uses a famous Taiwanese real estate agency to demonstrate the process of brand TV commercial script selection by implementing the proposed model. The proposed model will provide real estate agencies with an objective and effective method for selecting the optimum TV commercial script to promote their brand.

## 2. Literature Review

Television combines sight and sound to give benefits to both the media consumer and the advertiser that are unavailable through any other media. Television has the ability to be true to life and pervasive [14]. Under the original purpose of encouraging consumption, it not only sells a virtual space under construction but also offers the implicit meanings of this space; it is like a little world in a box that accommodates changes in the image qualities of sound and light. It is a microcosm of the world, and if we can produce an artistic point of view, that advertising will be connected to a different direction to shock the masses or touch their hearts [9]. The main functions of a TV commercial are to constantly remind consumers of a brand's existence to improve consumers' impression of the brand or to convey a message that hopefully directs communication with consumers. In today's pluralistic media environment, a TV commercial is the only kind of media that can reach more than 90% of consumers [26]. Therefore, no matter how strong a brand's awareness is, enterprises

can be certain that allocating their media budget to television will continue to increase their brand's impression and awareness, and thus reach a threshold of brand identity, thereby enhancing their willingness to buy additional TV time with each year's budget allocation.

"Advertising" is one of the four major tools used by companies to direct persuasive communications to target consumers [16]. Advertising allows people to understand and, thus, accept the terms of an activity. To motivate consumers to make a purchase, these activities are carried out using a promotional tool or are disseminated via word of mouth [3].

More specifically, the main purpose of advertising is establishment of basic needs (primary demand) that consumers can associate with the brand and the provision of benefits [18]. Advertising thereby enables enterprises to generate awareness and knowledge of the product. This approach can be applied to new product introductions, new uses for products, and price changes among others. Any product and service can be positioned "to meet demand, identify needs, and create demand." Advertising through persuasion or public information, increasing purchase rate, increasing brand awareness, meeting consumer needs and creating demand, making consumers think of a product—these are the intents of an advertisement [16].

The main purpose of advertising or brand advertising communications is, in accordance with a desired direction, to communicate the brand's aspiration in a manner that is expected to most attract consumers' attention. When executed well, such advertising can increase perceptions of the product's or brand's image, or influence consumers to buy the products. Effective advertising changes behavior to produce actual action. To bring about this behavior change, an advertisement's script needs to provide a potent motivation for the consumer that lasts longer than the advertisement itself.

An effective script is designed to showcase the product's characteristics, frequently using emotions as the main appeal, and often able to achieve good results [2]. Hence, the design of the script should show particular consideration towards the roles therein. Each role in the ad's script must offer just the right qualities that will hold up after subsequent performances. Because the emotions in the ads must be convincing, the roles must offer the audience a way to identify with the product [24]. With science and technology's rapid development, the concept of community also has begun to change as people's lives adapt to these advances. Visual advertising needs to reflect contemporary life; regardless of the advertising

techniques employed, the production values, such as actors, costumes, props, movement, language, and dialogue [5], need to be consistent with the trends of the times to resonate with consumers. Topics created in a brand advertisement to improve a gas company's image led to increased product sales for the company [27].

### 3. Methodology

This study employs two methods: the modified Delphi method and Grey Relational Analysis (GRA).

#### 3.1. Modified Delphi method

The traditional Delphi method requires continuous written and oral discussion and assessment among anonymous experts on a particular topic. These anonymous experts offer professional experience, knowledge, skills, and opinions, and exchange views with other experts until a consensus is reached [6]. The Delphi method comprises the following steps: (1) experts' selection, (2) first round of surveys, (3) second round of surveys, and (4) synthesis of experts' opinions to reach a consensus. Steps (3) and (4) are usually repeated until a uniform result is achieved for a particular topic. Furthermore, a literature review and expert interviews can integrate recurrent ideas expressed in a survey. Step (2) can then be simplified to replace conventional survey methods. The modified Delphi method, on the other hand, is a simplification of the abovementioned procedure [17] that not only saves time but also allows experts participating in the study group to focus on the study issue.

This study adopts the modified Delphi method to identify the evaluation criteria for selecting brand TV commercial scripts, which are determined using anonymous expert interviews and a survey of statistical outcomes regarding the research subject. Delbecq et al. [6] suggested that the appropriate number of members in a Delphi method group would be between five and nine individuals. This study employed a decision-making group composed of nine experts.

#### 3.2. Grey Relational Analysis (GRA)

In 1982, Professor Deng proposed the grey system theory which can be applied mainly in studies where the internal information system model is not sufficient, or where condition and operation information are not entirely clear [7]. Grey System Theory is mainly utilized to study system model uncertainty, analyze relations between systems, establish models, and

forecast and make decisions. GRA is used to examine the extent of connections between two digits by applying the methodology of departing and scattering measurement to actual distance measurement [7]. Hsu [11] used GRA to rank alternative public relations firms for the High-Tech Industry. Hsu and Kuo [13] applied GRA to select a city in China for building an international business office center. Hsu [12] also applied GRA to rank alternative media agencies and select the best one. Therefore, the following formula demonstrates the procedures for calculating grey relational grades [23]:

#### 3.3. Calculating grey relational grades

Let  $X_0$  denote the referential series with  $n$  entities:

$$x_0 = (x_0(1), x_0(2), \dots, x_0(n)),$$

and let  $x_i$  represent the compared series:

$$x_i = (x_i(1), x_i(2), \dots, x_i(n)), i = 1, 2, \dots, m$$

The grey relational grade for series  $X_0$  to  $x_i$  is then given as

$$\Gamma_{0i} = \frac{\Delta \min + \Delta \max}{\Delta' + \Delta \max} \quad (1)$$

where  $\Delta' = \sum_{k=1}^n w_k \Delta_{0i}(k)$ ,  $\sum_{k=1}^n w_k = 1$ ,  $w_k$  is the  $k$ -th element's weight,  $k=1, 2, \dots, n$ ,  $\Delta_{0i}(k) = |x_0(k) - x_i(k)|$ , and  $\Delta \max = \max_i \max_k \Delta_{0i}(k)$ ,  $\Delta \min = \min_i \min_k \Delta_{0i}(k)$ .

#### 3.4. Normalization (or making data dimensionless)

Before the grey relational grades are calculated, the series data can be treated using the linearity of normalization and the following three situations [25] to avoid distorting the normalized data:

Upper-bound effectiveness of measurement (i.e., the larger, the better):

$$x_i^*(k) = \frac{x_i(k) - \min_k x_i(k)}{\max_k x_i(k) - \min_k x_i(k)} \quad (2)$$

where  $\max_k x_i(k)$  is the maximum value of entity  $k$  and  $\min_k x_i(k)$  is the minimum value of entity  $k$ .

Lower-bound effectiveness of measurement (i.e., the smaller, the better):

$$x_i^*(k) = \frac{\max_k x_i(k) - x_i(k)}{\max_k x_i(k) - \min_k x_i(k)} \quad (3)$$

Moderate effectiveness of measurement (i.e., nominal-the-best):

$$x_i^*(k) = 1 - \frac{|x_i(k) - x_{ob}(k)|}{\max\{\max_k x_i(k) - x_{ob}(k), x_{ob}(k) - \min_k x_i(k)\}} \quad (4)$$

#### 4. Model and Application

In this study, we use a famous Taiwanese real estate agency to demonstrate the process for selecting the optimum brand TV commercial script. First, the composition of the decision-making team was determined: the team was formed from staff including the marketing project manager, the project assistant manager, and the senior specialist. Second, the real estate agency's internal selection process initially proposed three TV commercial scripts, labeled A, B, and C. According to the performance of the three scripts, the evaluative figures obtained from nine anonymous experts were then entered into the model for application. The proposed model uses the modified Delphi method to find suitable evaluative criteria of brand TV commercial scripts, and then applies GRA to rank the alternatives and select the optimal brand TV commercial scripts. These stages are detailed below as follows:

First stage: (a) Identifying critical evaluation criteria using the modified Delphi method, (b) Reviewing pertinent literature on major factors influencing brand TV commercial selection

Nine professionals, currently working as marketing senior managers, project managers, senior specialists or group account directors, account directors, and creative directors from prominent advertising agencies in Taiwan, were selected as respondents for the modified Delphi method. All respondents were professional managers with experience in TV commercial script selection. According to the related reference material, brand TV commercial script criteria can be categorized as follows: purposes of community message, ease in leading to consumer acceptance, appearance of the advertisement, effect of the advertisement, and commercial script content settings (See Table 1).

**Table 1. Criteria description**

Essential criteria	Sub-criteria	Criteria description
Purpose of community message	Establish consumer demand	The main purpose is to get the attention of the masses [18] to establish primary demand, thereby generating awareness and knowledge of the product among consumers [15].
	Establish consumer preferences	Establish consumer preferences so that consumers perceive the product with a positive attitude, build brand-selective demand, and convince consumers to purchase the product [16].
	Establish visibility in consumers' minds as a purchase option	Advertising through persuasion or public information, increasing purchase rate, increasing brand awareness, meeting consumer needs and creating demand, making consumers think of the product [16].
Ease in leading to consumer acceptance	Build an emotional connection with consumers	Emotions motivate consumers' purchase intentions. Advertisements appealing to consumers' instincts, drives, and emotions are called emotional appeals [16].
	Community brand or product position	Communicating the brand's or product's features that are beneficial to consumers through meaningful text, graphics, sound, and other approaches [4] to influence consumer perception and behavior [20].
	Increase in brand conviction	Provide effective factors and suitably strong appeals that can be accepted by consumers and produce the desired communication effect [30].
Ease in leading to consumer acceptance	Establish retention in consumers' memory	Using relaxing, witty, and funny approaches to make an impression on consumers and influence them through interesting themes [29].
	Strengthen the brand's positive values	Communicate to consumers to help them decide what is right and what is wrong [15].

Appearance of the advertisement	Comply with the enterprise's image	The bridge that connects the enterprise and consumers should help determine the basic structure of the entire ad performance [15]. According to the enterprise's expectations, the best characteristics of the product and brand should be conveyed [22].
	Meet the target consumers' demands	Create a problem situation experienced in daily life, highlighting the problem that is most easy to remember, and emphasize the product as the only way to solve the problem [1].
	Establish a sense of trust with consumer	Prove that the product itself has a very particularly advantageous feature, but pay attention to attract the interest of the consumers [8].
	True reflection of brand through the advertisement	Take word-of-mouth promotions to the advertisement. All testimony should be based on the truth [1].
	Reinforce credibility	"Seeing is believing." Demonstrate the important selling points in commercials can increase the credibility of advertising [1].
Effects of the advertisement	Affective marketing	Visualize a story with words and music; the story can play an excellent form affecting consumers' perceptions [2].
	Remove the boundary line between consumers and the brand	It is important to represent the product as an essential tool in the daily life while initiating the resonance of the brand among consumers [8].
	Establish creative favorability	The enterprise should maintain the image of products and advocate them through advertising strategies [19] but still create interesting elements to increase the impression of product [27].
Commercial script content settings	Trends	Trends should comply with the product or brand [5] but also have relevance in consumers' daily life [27].
	Emotions	Emotional performance is the key to leading to consumer acceptance [1].
	Slogan	The slogan can convey the enterprise's impression in the minds of consumers, but it requires a long time to achieve effectiveness [2].

Second stage: Applying GRA for optimal brand TV commercial scripts selection

Step 1: Operational definition of criteria and data treatment

GRA assessment criteria, indicators, operational definitions, and data processing in these three brand TV advertising scripts are in line with the above 19 criteria. A 10-point Likert scale, ranging from "very unimportant" (1 point) to "very important" (10 points), is used to ensure criteria are weighted correctly. When a criterion gets over nine points, it will be listed as an important reference criteria for this model. Community experts determine the criteria for the evaluation model and implement the modified Delphi method for reaching a consensus and achieving uniform recognition. This study obtained five essential criteria and 19 sub-criteria after two rounds of survey (Table 2).

Step 2: Identify the referential series

We then identified the referential series  $X_o$ . Using the formula mentioned above, we arrived at the following values for brand TV commercial scripts: purpose of community message to establish consumer demand (K1) max 8.33; establish consumer preferences (K2) max 8.33; establish visibility in consumers' minds as purchase options (K3) Max 8.67; build an emotional connection with consumers (K4) max 8.00, and so on to the slogan (K19) a maximum of 8.00, to achieve reference sequence  $X_o = (8.33, 8.33, 8.67, \dots, 8.00)$ .



Step 3: Consider the values of three brand TV commercial scripts

In Table 2, we consider the values of three brand TV commercial scripts' 19 criteria as compared with series,  $x_i = (x_i(1), x_i(2), \dots, x_i(19))$ ,  $i=1,2,3$ .

Step 4: Normalize individual criteria values.

Normalize Table2 using formulae (2) to obtain  $x_i^*(k)$ , before calculating gray relational grades, in case

of differences among individual criteria units.

Step 5: Calculate the difference series

We then calculated the difference series,  $\Delta_{0i}(k) = |x_0(k) - x_i(k)|$ ,  $k=1,2,\dots,18$ , as shown in Table 3.

**Table 2. Criteria and data of brand TV commercial scripts**

Code	Criteria	Script A (i=1)	Script B (i=2)	Script C (i=3)
K1	Establish consumer demand	3.333	6.667	8.333
K2	Establish consumer preferences	3.667	6.667	8.333
K3	Establish visibility in consumers' minds as purchase options	4.333	7.333	8.667
K4	Build an emotional connection with consumers	4.333	7.000	8.000
K5	Community brand or product position	4.667	7.667	8.000
K6	Increase brand conviction	4.000	6.000	8.667
K7	Establish retention in consumers' memory	7.333	6.333	8.667
K8	Strengthen brand's positive values	4.000	7.333	8.667
K9	Comply with the enterprise's image	6.333	7.667	8.667
K10	Meet the target consumers' demands	4.333	7.000	8.000
K11	Establish a sense of trust with consumers	5.333	7.667	8.000
K12	True reflection of the brand through the advertisement	4.667	6.333	8.333
K13	Reinforce the credibility	3.333	6.333	8.000
K14	Affective marketing	4.333	6.667	8.333
K15	Remove the boundary line between consumer and brand	4.000	7.333	8.67
K16	Establish creative favorability	3.333	7.000	7.000
K17	Trends	2.667	5.667	7.000
K18	Emotions	6.667	7.333	8.000
K19	Slogan	8.000	6.667	8.000

**Table 3. Difference series and grey relational grade for each compared series  $\Gamma_{0i}$**

Code	Criteria	Script A	Script B	Script C
K1	Establish consumer demand	1.000	0.333	0.000
K2	Establish consumer preferences	1.000	0.357	0.000
K3	Establish visibility in consumers' minds as purchase options	1.000	0.308	0.000
K4	Build an emotional connection with consumers	1.000	0.273	0.000
K5	Community brand or product position	1.000	0.100	0.000
K6	Increase brand conviction	1.000	0.571	0.000
K7	Establish retention in consumers' memory	1.000	1.000	0.000
K8	Strengthen brand's positive values	1.000	0.286	0.000
K9	Comply with the enterprise's image	1.000	0.429	0.000

K10	Meet the target consumers' demands	1.000	0.273	0.000
K11	Establish a sense of trust with consumer	1.000	0.125	0.000
K12	True reflection of the brand though the advertisement	1.000	0.545	0.000
K13	Reinforce credibility	1.000	0.357	0.000
K14	Affective marketing	1.000	0.417	0.000
K15	Remove the boundary line between consumer and brand	1.000	0.286	0.000
K16	Establish creative favorability	1.000	0.000	0.000
K17	Trends	1.000	0.308	0.000
K18	Emotions	1.000	0.500	0.000
K19	Slogan	0.000	1.000	0.000
	$\Delta'$	0.925	0.393	0.000
	$\Gamma_{0i}$	0.520	0.718	1.000
	Rank	3	2	1

#### Step 6: Calculate individual compared series and gray relational grades

Next, we calculated  $\Delta'$  of individual compared series and grey relational grades  $\Gamma_{0i}$  by formula (1), as shown in Table 3. This study assumes that the 19 criteria have equal weight ( $w_k = 1/19$ ), as shown in Table 3.

#### Step 7: Select the optimal brand TV commercial scripts

Based on grey relational grades  $\Gamma_{0i}$  in Table 3, the rankings of the brand TV commercial scripts are Script C (1.000), Script B (0.718), Script A (0.520). In sum, the optimal brand TV commercial script is Script C.

### 5. Conclusions

Advertising is one of the channels used by enterprises to introduce their product or brand. The extent to which an advertising message can be stored is limited, so every instance of advertising communication with the enterprise's target audience requires consideration of several factors, such as the issue of how to spread the message in the medium and manner most likely to result in consumer acceptance of the points the enterprise wants to communicate, and intriguing presentation of the enterprise's features most appealing and relatable to the target audiences' life. Content that satisfies these needs form a commercial script's basic elements. With budgetary control in the hands of enterprises, however, advertising firms do not have free reign in creating an advertising campaign, and the high cost of access to TV media also needs to be considered when creating TV advertisements. A well-thought out commercial can enhance consumers' perceptions of a brand, so deciding upon the precise

content of an advertisement requires much consideration of various factors., Determining the optimum advertisement script and content, therefore, requires input from a range of stakeholders in an enterprise, but as the number of people involved increases, so does the potential for disagreements. This study has presented a method of using modified GRA to apply weighting to these various input factors to streamline and guide this decision making process.

In this study, we used the case study of a real estate agency's brand marketing manager's point of view towards the brand TV commercial scripts in constructing a decision-making model. Part one of this model used a modified Delphi method first and relevant literature next to identify appropriate selection criteria. In part two, GRA was applied to an advertising agency's proposed creative solutions to rank and select the top tier of optimal brand TV commercial scripts. These top rated possibilities, along with their rankings based on the grey relational grades in Table 3, were then presented to the Taiwanese real estate agency for a final decision. The rankings of the brand TV commercial scripts from applying this approach were Script C (1.000), Script B (0.718), and Script A (0.520). In sum, the optimal brand TV commercial script was the Script C.

In addition to the commercial's script as the manifestation of a brand's image, an enterprise's media planning strategy cannot ignore factors such as the actors, music, and scene selection, as well as other forms of media as an extension of TV media marketing. For example, retail marketing activities should be the focus of the real estate brokerage company's subsequent media strategy development process.

The TV commercial scripts selection process in the case study involved the following steps: first, the real estate agency's professional managers were involved in the selection of TV commercial scripts, where desired qualities of the advertising campaign, such as the mood, the ideal customer, the connection desired with the consumer, and the brand's integrity, were determined. Second, the location and timing of the advertisement's broadcast needs to be considered, since this will affect the length of the script. In addition, because the ad is the real estate brokerage company's main means of communicating with consumers, the location and timing of the advertisement determines whether it will reach the target audience. Thus, many factors need to come together to create a successful advertising campaign that appeals to consumer's emotions and needs, creates a sense of connection between the brand's values and consumers' identities, and therefore motivates consumers to contact the agency. The more successfully an advertisement achieves these needs, the higher consumers' opinions of the brand, and the higher the likelihood that the advertisement will translate into increased sales.

With the diversification of media channels, the need for television commercials is also increasingly being questioned. Given the unquestioned need for businesses to continue to advertise their services and increase awareness of their brands, the impact of the proliferation of media forms and outlets upon the next generation of Taiwan's consumers, we recommend follow-up research that can develop a real estate agency's brand advertising in a different media using a different selection planning strategy under the brand advertising content model.

## 6. References

- [1].Baldwin, H., *How to Create Effective TV Commercials*, Natl Textbook Co Trade, 2<sup>nd</sup> edition, USA, 1989.
- [2].Barry, P., *The Advertising Concept Book*, Thames & Hudson, London, 2008.
- [3].N.H. Borden, "Testimonial to Ralph Starr Butler," *Journal of Marketing*, 25 (5), 1942, p. 73.
- [4].Burgoon, M., *Messages and Persuasive Effects: Message Effects in Communication Science*, Sage, Newbury Park, CA, 1989.
- [5].Cury, I., *TV Commercials-How to Make Them or How Big Is the Boat?*, Focal Press, Amsterdam/Boston, 2005.
- [6].Delbecq, A.L., Van de Ven, A.H., and Gustafson, D.H., *Group Techniques for Program Planning: A Guide to Nominal Group and Delphi Processes*, Scott, Foresman and Company, Chicago, 1975.
- [7].J.L. Deng, "Introduction to Grey System Theory", *The Journal of Grey System*, 1 (1), 1989, pp.1-24.
- [8].Dentsu Inc., *CM how planning - TV, radio advertising*, Chaoyang Church, New York, 1988.
- [9].Eagleton, T., *Walter Benjamin, or, Towards an evolutionary criticism*, Verso, 1981.
- [10].Hsiao, H. W., *Advertising Communication*, Weishi Man culture, New York, 2009.
- [11].P. F. Hsu, "Developing a New Model for Selecting Public Relations Firms in the High- Tech Industry", *Journal of Modelling in Management*, 1 (2), 2006, pp.156-172.
- [12].P. F. Hsu, "Selection Model Based on ANP and GRA for Independent Media Agencies", *Quality & Quantity*, 46 (1), 2012, pp. 1-17.
- [13].P.F. Hsu and M.H. Kuo, "An Application of the GRA & Entropy to Selecting a City in China for an International Business Office Center", *The Journal of Grey System*, 19 (3), 2007, pp.269-282.
- [14].Katz, H., *The media handbook*, Lawrence Erlbaum Associates Publishers, Mahway, NJ, 2003.
- [15].Keegan, W. J. and Green, M. C., *Global Marketing*, Prentice-Hall, Upper Saddle River, NJ, 2011.
- [16].Kotler, P. and G. Armstrong, *Principles of Marketing*, Prentice-Hall, Upper Saddle River, NJ, 2013.
- [17].J.W. Murry and J.O. Hammons, "Delphi: A versatile methodology for conducting qualitative research", *The Review of Higher Education*, 18 (4), 1995, pp. 423-436.
- [18].Postma, P., *The New Marketing Era*, McGraw-Hill, Upper Saddle River, NJ, 1998.



[19]. Moriarty, S., Mitchell, N., and Well, W., *Advertising Principles & Practice*, Prentice-Hall, Upper Saddle River, NJ, 2005.

[20]. Simon, J. L., *The Management of Advertising*, Prentice-Hall, Englewood Cliffs, NJ, 1971.

[21]. Stanley, R. E., *Promotion Advertising, Publicity, Personal Selling, Sales Promotion*, Prentice-Hall, Upper Saddle River, NJ, 1982.

[22]. H. J. Tsai, "Decoding Real Estate Corporation Advertising Strategy", *Kun Shan University*, 8, 2011, pp. 31-45

[23]. K.L. Wen, "The cardinal form of Grey relational grade", *Journal of The Chinese Grey System Association*, 2 (2), 1999, pp. 117-133.

[24]. White, H., *How to produce Effective TV Commercials*, NTC Business Books, 1989.

[25]. J.H. Wu and C.B. Chen, "An alternative form for gray relational grades", *The Journal of Grey System*, 11 (1), 1999, pp. 7-12.

[26]. Taipei Media Agency Association, MAA Media Book, 2013.

[27]. Liu, Y. L., *The Film's Successful Advertising Creative and Production*, National Press, Taipei, 2012.

[28]. Advertising message appeals, (Accessed on 05/10/ 2010), Wikipedia [http://zh.wikipedia.org/wiki/advertising\\_message\\_appeals](http://zh.wikipedia.org/wiki/advertising_message_appeals)

[29]. Marketing Management: humorous advertising four to do with the four, (Accessed on 06/02/2012), Commercial Times, taken from <http://chinesebiznews.com/index.php/component/content/article/46-scjy/9493-2010-02-07-06-24-25.html>

[30]. Fear appeals, (Accessed on 05/01/2013), MBA lib <http://wiki.mbalib.com/wiki/fearappeals>

## A Transition Process of Industry-University Collaboration

Tai-Yue Wang

*Department of Industrial and Information Management, National Cheng Kung University, TAIWAN, ROC*  
[tywang@mail.ncku.edu.tw](mailto:tywang@mail.ncku.edu.tw)

You-Cheng Dai

*Department of Industrial and Information Management, National Cheng Kung University, TAIWAN, ROC*  
[albert.dai@msa.hinet.net](mailto:albert.dai@msa.hinet.net)

### **Abstract**

*Equivalent relations among government-university-industry (GUI) are considered pivotal in developing knowledge-based economy (KBE) that most governments are eager to achieve. Laissez-faire and Triple Helix models have been used to depict GUI relationships, and the latter is considered to be more suitable for KBE and been adopted by numerous countries. However, the transition process between them has been ambiguous, causing difficulties in drafting practicable policies. This study aimed to explore the transition process from Laissez-faire to Triple Helix model. The results indicated that relationship building at the individual level is the keystone to GUI interaction, especially for firms and faculty members who have no prior experience of collaboration. An incubating mechanism is essential to start UI collaboration. An example of incubation on UI collaboration been implemented in Taiwan was verified in this study. It is hoped that the mechanism may inspire policy makers in designing policy tools to boost GUI interactions.*

### **1. Introduction**

Knowledge has been recognized as a key factor in the regional and national competitiveness, which makes knowledge-based economy a predominant concept of policies across the world. The extent to which knowledge can facilitate economic development depends on its capacity and capabilities to help generate new ideas, processes and products, and sequentially to transform them into economic value and wealth through the science and technology system

of regions or nations [1][2]. Since the beginning of the twenty-first century, developing knowledge-based economy (KBE) to replace former labor-intensive or industry-based economy has become a policy goal that most countries are eager to achieve, as the pressure of changing industrial structure becomes increasingly severe. Being the core institutes of the science and technology system of a nation, universities are supposed to carry more tasks beyond knowledge-creating, teaching and research. In recent years, the idea that universities can play the "third role", i.e. to make direct contributions on national and regional economic development, is emerging and has quickly attracted the attention of many policy makers [3][4].

The contributions that universities in this third role can make are mainly from university-industry collaborations. A number of cases can be used to demonstrate these contributions to economic growth both in a regional as well as national context. One typical example is the legend of Silicon Valley in the United States. Other examples include the North East Productivity Alliance (NEPA) program in the North East England, Temporary Entrepreneurship Position (TOP) program in Netherlands, and New University for Regional Innovation (NURI) project in South Korea [5]. The third role that universities play varies considerably across different countries, depending on the policies being implemented [6]. In Germany, for example, a heavy emphasis was put on knowledge and technology transfer from universities to the private sectors. These examples have convinced governments all over the world of the strong role that universities could play in their research and innovation policies [7]. While it comes to transferring the

experiences from those developed countries, governments have found it a daunting task to be undertaken since the size and economic status of each country vary significantly [8]. Unlike universities in the US which have less financial support from the government and behave more like entrepreneurial corporations [9], universities in this region focus more on education than on facilitating industry upgrading [10], and it is therefore necessary for the intervention of government policies to reshape the institutional culture of universities, reduce barrier and encourage university-industry (UI) collaboration. Two basic tools that governments could use in fostering university-industry collaboration include: providing financial support for research and designing some incentives to improve the interaction between them. A balanced and effective interaction among government-university-industry (GUI) is thus pivotal to economic development.

GUI interactions can be best illustrated in terms of the Triple Helix model [11]. Seeking to enhance more intensive interactions of GUI, the Triple Helix model is considered to be a positive synergy among GUI in knowledge spillovers and is widely exploited in developed as well as developing countries [12][13][14][15][16]. Though emphasizing on the overlapping yet independent interactions between the aforementioned three institutional spheres, the Triple Helix model represents a transition from a *laissez-faire* model, with spheres separate from each other. In the opinion of Leydesdorff and Etzkowitz [11], the knowledge-based economic regime has made the *laissez-faire* model obsolete. However, the transition process from *laissez-faire* model to Triple Helix model has not been well explained in studies by Etzkowitz and Leydesdorff and other researchers. This missing part has made it difficult for practitioners to transform Triple Helix thesis into practicable policies [17]. For instance, do those formerly independent institutional spheres spontaneously approach and even overlap with each other? If not spontaneously, what is the driving force that pushes or pulls each other together?

The purpose of this research is to answer the aforementioned questions by providing a detailed description on the transition process from *laissez-faire* to Triple Helix model. Specifically, we will first analyze the differences between the two models through a decomposition of the transition process. By means of decomposition, the transition process can be further divided into several steps, to which policy makers can refer and design the most effective approach to bridging the gap among GUI interaction. Secondly, we will review literature concerning Triple

Helix and GUI relationship based on an inductive analysis and propose a practicable transition process with visual presentation. A case of UI collaboration incubation between faculty members of universities and firms (especially, SMEs) that have no prior experiences of UI collaboration is then introduced to verify the process.

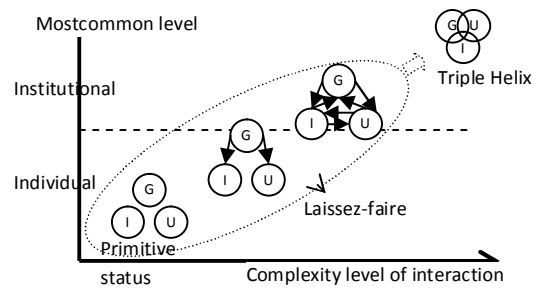
## **2. From Laissez-faire to Triple Helix: analysis of the transition process**

Before exploring the transitional phase, a comparison on definitions of *laissez-faire* and Triple Helix models shall be helpful in understanding the detailed transformation concerning these two models. In the state of *laissez-faire*, the borders of each institutional sphere are strong and each of them is assumed to serve the society only for a single purpose. Organizations belonging to a specific sphere are expected to stay within their respective boundaries. Therefore, the role of government is limited to maintaining the free market mechanism, the university is the human resources and knowledge provider, and the industry is predominately linked through market interactions [1]. Furthermore, the relationship among GUI is built in an indirect way, 'with one sphere influencing another to affect a third sphere' [18]. On the contrary, the borders between GUI in Triple Helix model are vague and each institutional sphere may 'take the role of the other' in addition to their preset functions, which has resulted in a system of overlapping interactions that did not exist before [19]. For example, when universities have successfully transferred technologies to local enterprises and created a number of spin-offs, they are playing the role of local government to facilitate regional economic development as well as regional innovation. In this respect, the communications in the Triple Helix model are more complicated than other innovation models since they include bi-lateral and tri-lateral interactions among GUI, which will eventually evolve into networks of communication [20].

Comparing the definitions of the above two models, it can be observed that the main difference between them is the overlapping part of each sphere, especially the intersection portion at the core of the three spheres that Etzkowitz and Leydesdorff called 'tri-lateral networks and hybrid organizations.' [19] However, in the real world, overlapping represents a breakthrough of interface between institutional spheres. To cross the border, relationship building is the keystone [21]. That is, converting the separated sphere into an overlapped system takes time to build the relationship and

ignite the spark of collaboration. Further, by means of collaboration between spheres, the barrier between them are vague and insignificant. In brief, it can be concluded that the transition process from laissez-faire to triple helix is a process of relationship building among organizations in different spheres. Another difference that Etzkowitz and Leydesdorff have highlighted is the enhanced role of universities. In their opinion, universities shall be a pivot of industries innovation and drivers of economy development both at national and regional level in the future. However, they have merely pointed out the outcomes with some luminous examples but failed to provide a solution when universities are not as proactive as expected in conforming to government's innovation policies concerning UI collaboration. The comparisons have provided a subtle insight into the transition process.

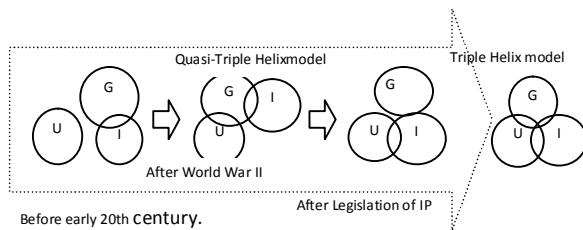
Inzelt [21] has collected eighteen types of GUI interactions, ranging from ad hoc consultation to joint research activity, and consolidated them into a summary table. Based on the Inzelt's study, a simplified diagram (as shown in Figure 1) can be derived by replacing the 'types of interaction' with 'complexity level of interaction' and preserving the 'pattern of interactions' among the three spheres of GUI and 'most common level' to compare the differences between laissez-faire and triple helix. However, it can be found from Figure 1 that the transition process is ambiguous in his study as well. Still, there are some clues in Inzelt's study. First, the transition process shall start from the individual level, normally knowledge exchange through personal consultation, training as well as the flow of personnel from academia to enterprises or vice versa. Secondly, as the common level evolves from the individual level to the institutional level, governments are expected to dominate the interactive activities by direct government interventions, such as initiating large-scale innovation projects to foster university-industry links and so forth. This situation may be manifested by the evolving process of industrial innovation. Formerly, the innovation function was mainly the single preserve of either industry or the government. Industrial policies made by the government, such as tax exemption and Small Business Innovation Research (SBIR) Programs, mostly focused on the relationship between the government and firms.



**Figure 1. GUI interaction pattern (revised from [21])**

As KBE has increasingly attracted attention from the government, universities assume a more prominent role in the innovation system. Taking the US as an example, the entire research university system was required to transfer technology in 1980 under the Bayh-Dole Act which authorized intellectual property rights from federally funded research to the university, with the clause that they shall make their best to commercialize these rights. Since then, university-industry collaborations, such as joint ventures, research consortia, university-sponsored research parks, have become more and more frequent. Thirdly, as the frequency of interaction increases, networks of communication have formed, which may lead to the overlapping of GUI in the long run.

In the process of industrial innovation, the dot-lined arrow as indicated in Figure 1 can be further analyzed and replaced by three transitional states, as shown in Figure 2. Each state is divided chronologically based on distinctive historical events as described previously. It can be noted that GUI interaction does not occur spontaneously but in a stepwise manner with UI interaction as the last knot to tie all of them together. It is named 'quasi-Helix Triple' model since the central intersection part is not yet formed at the last state. It is the state when universities start to play an enhanced role by leading innovative activities that Etzkowitz and Leydesdorff have emphasized in their works. To sum up, it can also be concluded that the success of UI collaboration may affect the performance of triple helix circulation significantly. Therefore, from a policy-making perspective, incubations on UI collaborations are the foundation of GUI relationship building and should not be neglected in the process of formulating national and regional innovation policies.



**Figure 2. The changing states of GUI interaction based on industrial development**

### 3. The case of transition process in Taiwan

In this section, we will introduce an example of GUI collaboration in Taiwan. Starting from the early 1990s, Taiwan government has initiated a number of projects to encourage UI collaboration. Yet the number of UI collaborated projects was comparatively lower than what was expected over the past twenty years. To improve the situation, Taiwan government proposes a novel approach which is depicted in this section.

#### 3.1. Background

Facing the challenge of globalization, a plan to develop KBE was initiated by the government of Taiwan in 2001. One of the strategies to develop KBE was to set up a mechanism, including GUI cooperation, to foster innovation. To promote cooperation among GUI, many government agencies, such as the National Science Council, Ministry of Education and Ministry of Economic Affairs, have created their own strategies and programs, with an emphasis on increasing innovation capabilities of firms. The case introduced in this study is a program sponsored by Department of Industrial Technology (DOIT), an agency supervised by Ministry of Economic Affairs. Being the most important agency in the government to plan and implement industrial innovation policies in Taiwan, DOIT is responsible for integrating R&D resources from private sectors, academics, and research institutes to upgrade the level of industrial technologies and activate their cooperation through funding the "Technology Development Program" (TDP). The scope of TDP is comprehensive, covering research institutes, private sectors and universities.

Since more than ninety percent of firms in Taiwan are SMEs, Small Business Innovation Research (SBIR) program, among various TDPs, is regarded as the most suitable indicator to monitor the innovation capabilities of SMEs in Taiwan. Mostly referred to the SBIR US version, the SBIR Program was set forth by Taiwan

government in 1998 and 4,255 proposals were submitted, 2,500 of them were approved in a decade. However, according to the statistics announced by Office of SBIR program, more than half of these enterprises were located in northern Taiwan, which means a serious geographic imbalance of regional innovation. To improve the situation, an investigation was made to explore the reason why enterprises in other areas were less interested in SBIR applications. The results showed that the major obstacle to applying for SBIR grant was the inability to prepare those required documents, especially R&D plan. They were forced to give up the opportunities even though they already have some excellent ideas or researches. In contrast, another group of SMEs were facing a different kind of challenge that came from their perplexity about the future, and they need immediate and comprehensive diagnosis of their firms and practicable advices for the future to remain sustainability.

On the other hand, in spite that government in Taiwan has actively promoted university-industrial collaboration over twenty years, the ratio of R&D funds contributed by private enterprises to universities was merely 5.3%, much lower than that of government's contribution (85.9%) per statistics reported in the 'Indicators of Science and Technology-Taiwan' (Taiwan National Science Council, 2008). In addition, the majority of the R&D workforce with doctoral degree was concentrated in universities, second only to private enterprises. These figures have inspired DOIT that the R&D workforces in universities were not well cultivated. Consequently, they have proposed that faculty of academic institutions could provide government-funded consultation on respective enterprises in a lagging region to assist them in outlining innovation strategy and applying for SBIR program. However, SMEs of traditional industries in Taiwan are comparatively unwilling to collaborate with universities due to their perception that researches by university faculties usually have fallen short of meeting their actual demand. Therefore, before formal collaboration with universities, a stage of relationship incubation will be beneficial to long-term cooperation and mutual trust in the future. Based on this situation, a prerequisite to be fulfilled by DOIT was design an incentive TDP to reduce barriers to UI collaboration and facilitate the willingness of academics to work with SMEs.

In 2007, a pilot TDP was initiated and implemented for one year to verify the feasibility. Since southern Taiwan is a less innovative area as compared to other regions in Taiwan, the scope of the TDP was limited to

this region. After making some improvements in the mechanism, the TDP entitled 'Tech-caring for Traditional Industries in Southern Taiwan Program' (TTIST) was approved by the authorities of DOIT and launched in 2008.

### **3.2. Tech-caring for Traditional Industries in Southern Taiwan Program: touchstone of university-industry relationship incubation**

The program is intended to achieve two goals: in the short term, to increase the innovation capability of traditional industries in relatively lagging region through the assistance of universities; in the long term, to build a relationship between university and industry initially by government's deliberate intervention while finally reaching the status of Triple Helix. Indicators for evaluating the performance of this program include number of UI collaborative cases and growth rate of SBIR applications. Emphasizing on relationship incubation, the mechanism designed in TTIST program has considered both obstacle-reducing and relationship-facilitating factors in the process of UI relationship building. As for obstacles, Hadjimanolis [22] has divided the most common obstacles into the four categories of 'relationship related,' 'institutional,' 'internal,' and 'knowledge transfer related.' Among them, relationship-related obstacles, which may be caused by the cultural, perceptual, communicational, motivational, social and political differences between enterprise's owners and academic researchers, are the primary issue to be addressed in this study. To solve this problem, several procedures were built in the program mechanism.

First, some senior and prestigious academics with prior collaborative experience are invited to join the program as members of a consulting committee. The main function of this committee is to select an academic from a pool of candidates that can best match the demand of the enterprises. Such a screening function could alleviate possible conflicts due to communicational and social differences in the subsequent UI collaboration. Secondly, a Standard Operating Procedure (SOP) that delineates flowcharts, mandate documents and requirements, has been developed for each participant engaged in TTIST program to follow. For example, each participant has to submit a proposal to be reviewed by the committee. Once the proposal has been approved, each participant is required to visit the firms at least twice per month and hand in a research plan to apply for SBIR program at the end of a nine-month duration. A diagnosis report is also acceptable in case of failure to focus on

any specific topic in such a short period. Thirdly, a regular meeting is held for participants to share their experiences so as to relieve the beginner's anxiety. On the facilitator side, to encourage and even lure university faculties who have no prior experience of collaboration with enterprises to make a trial and vice versa, DOIT offers each participant some pocket money by month for the consulting services to enterprises over a period of nine months. Besides financial rewards, some participants considered the program as a good opportunity to get familiar with the actual need of industries so as to expand their scope of researches.

To make university faculties and enterprises become interested in TTIST program and willing to participate in the program, promotional activities, such as holding symposia and create a website, are necessary in the start-up stage. There are two possible sources of UI collaborations: one comes from the enterprise or the university faculty who can find partners for cooperation by themselves, and the other source comes from UI 'matching,' enabled by a 'matchmaker' assigned by the committee. Matching is the most difficult but a distinctive part of the program. Upon receiving request from a firm not knowing how to start UI cooperation, the matchmaker, usually a senior professor who is experienced with UI collaboration and equipped with excellent communication skills, will visit the enterprise to interview top management and understand the needs. Evaluating on the basis of the industrial sector and the firm's capabilities, such as core technique, human resources, immediate demand and so on, The matchmaker will then recommend at least three candidates for the firm to select the most appropriate one. The matching process sometimes will last for months and even fail in the end in a few extreme cases. To ensure each case is proceeding as required, Office of TTIST program randomly sample some projects for review during the incubation period. Should some conflicts occur, the matchmaker will intervene to mediate or change consultant in the case of serious discrepancies. Under these processes, only one of the 214 projects has been withdraw in two years.

### **3.3 Performance of TTIST Program**

Till the end of 2008, a total of 214 cases of collaboration had been approved by the committee under the program, in which 64 of them were linked by matching and one was suspended for the sake of control. Seeking further improvement, the Office in charge of TTIST program made a survey on the

mechanism of the program through mailed questionnaire with 150 samples that included academic and enterprise parties respectively. The numbers of valid questionnaire returned were 73 and 51 for academic and enterprises respectively. Results of the survey showed a high percentage of satisfaction about the mechanism, as shown in Table 1. It can also be observed from Table 1 that enterprises were more satisfied with the program since none had identified themselves to be 'unsatisfied' and 'very unsatisfied'. Another evidence to demonstrate the effectiveness of this program was growth in the numbers of proposal for SBIR program in southern Taiwan. As shown in Table 2, the number of proposals submitted increased significantly from 20% to 22.3% since 2007 [23].

**Table 1. Frequency and percentage of academic versus enterprise in the program satisfaction survey**

Type	Very Satisfied		Satisfied		Unsatisfied		Very Unsatisfied	
	n	%	n	%	n	%	n	%
Academic	2	3	4	6	3	4	0	0
Enterprise	4	3	6	3	0	0	0	0

**Table 2. Percentage of total SBIR applications by region in Taiwan (Taiwan Office of SBIR Program, 2008)**

Region	Year			
	2005	2006	2007	2008
Northern Taiwan	59.5	63.1	56.5	54.5
Central Taiwan	22.9	19.6	23.2	20.7
Southern Taiwan	17.0	16.7	20.0	22.3
Other areas	0.6	0.6	0.3	2.5

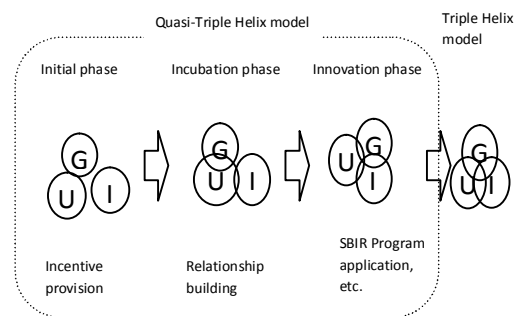
#### 4. Discussion and conclusion

##### 4.1 Discussion

The model presented in this study illustrates the detailed path of transition from laissez-fair to triple helix. Instead of a chronological order, the process is divided into three phases based on main activities (shown in Figure 3): initial phase, incubation phase and innovation phase. At the initial phase, the government identifies the need and actively approaches university to figure out a mechanism that could effectively

facilitate UI collaboration. At the incubation phase, the faculty members in universities have proactively sought for industry's cooperation by assistance from the matchmaker to incubate UI relationship due to attractive incentives or some other motives. Coming to the innovation phase, industries become the center of innovation and are capable of utilizing the government's granted programs through a collaborative research project with universities.

It can be realized that, among the three institutional spheres of original laissez-fair model, the government is the most appropriate one to promote the transition process, especially in regions where the concept of UI collaboration is just emerging. Unlike the intersection part at the core of Triple Helix model, the three spheres at the third phase of quasi-Triple Helix model do not intersect in the center since the interaction remains at bi-lateral and individual level. Once the cases of collaboration increase, a tri-lateral network will form and quasi-triple helix will evolve into triple helix.



**Figure 3. The transition process based on the case**

##### 4.2 Conclusion

Obligated to preserve competitiveness and economic growth in a globalizing economy, policy makers in the world have a growing interest in the KBE. In response to the trend, the traditional role of universities has been challenged and they are required to take more responsibilities in promoting regional economies by means of transforming knowledge into economic value through collaboration with industries. In the perspective of economic development, interactions among actors of a regional innovation system are beneficial to increase regional innovative capabilities. However, a subtle policy issue remains as to make individual entities open their boundaries,



which were formerly closed and constrained by their original characteristics, and embrace the other entities. Each government has its own trajectory in the transition to KBE, but all governments have invested huge amounts of resources to encourage UI collaboration. GUI relationships therefore have been widely discussed in recent years.

Either laissez-faire model or Triple Helix model can be a way to visually expressing GUI relationships and has been empirically verified in the developing stages of some countries. Since Leydesdorff and Etzkowitz [11] claimed laissez-faire model is obsolete in the era of KBE, a number of countries in Asia Pacific, such as Singapore [24], Malaysia [25], Indonesia [12] as well as Taiwan, have adopted the concept of Triple Helix model and tried to make it a practicable policy by diverse government-funded programs at the national or regional level.

Through an extensive review of literature and cases concerning triple helix model and GUI relationships, this study has identified and addressed some theoretical insufficiency through an exploratory study on the transition process from the laissez-faire model to the triple helix model. The process was analyzed in the viewpoint of industrial revolution and by aggregating all types of GUI interaction, and it was then divided into three more detailed transitional phases. A case was proposed to illustrate the changing phases of GUI arrangement and each phase was represented by a major institutional activity. In addition, the case has manifested the procedures to incubate relationship between firms and university faculties who have never participated in UI collaboration.

The implications of this study are summarized as follows. For policy makers, the results of this study indicate that relationship building at the individual level prior to transition at the institutional level shall be a foundation of GUI triple helix. However, relationship building will not occur automatically. Few studies have considered the situation about how to assist enterprises and university faculties with no experience of UI cooperation in making the start. A possible and effective mechanism has been proposed in this study with a case implemented in Taiwan to illustrate the procedures. It is hoped that the mechanism may inspire policy makers in designing policy tools to boost GUI interactions.

As for the industries, this study has inspired the management of enterprises that taking part in the UI relationship incubating platform offered by the public sectors can not only decrease the uncertainty but also alleviate the anxiety on corporation in the early stage, which may be the most accountable way to gain

academic R&D resources in promoting innovation capabilities. It is suggested that enterprises, especially SMEs with inferior capabilities in innovation, shall be more open-minded and proactive when seeking opportunities of up-grading or transformation into a new territory, no matter product-based or technology-based.

In addition, despite that Viale and Etzkowitz [4] suggested universities in developing countries take a leading role in triple helix model, results of this study show that government's deliberate intervention have occurred in most cases and is an important driving force for interactions within GUI in the early stage. It is not a contradiction but a discovery that an incubation of entrepreneurial university is necessary.

As for future studies, the equilibrium state that Triple Helix model advocates may be too perfect to reach. There will be various paths to the final state, depending on the initial state of GUI. The case introduced in this study has sketched one possible path, and it is hoped that more possible paths may be proposed in the future to enable a better understanding of the role transformation during the transition process so as to facilitate GUI collaboration in a more efficient and effective way.

## References

- [1] Huggins, R., Jones, M., & Upton, S. (2008) 'Universities as drivers of knowledge-based regional development: a triple helix analysis of Wales', *International Journal of Innovation and Regional Development*, Vol.1 No.1, pp. 24-47
- [2] OECD (1996) *Employment and Growth in the Knowledge-based Economy*. OECD Publishing, Paris.
- [3] Martinelli, A., Meyer, M. & Tunzelmann, N. (2008) 'Becoming an entrepreneurial university? A case study of knowledge exchange relationships and faculty attitudes in a medium-sized, research-oriented university', *Journal of Technology Transfer*, Vol. 33, pp. 259-283
- [4] Viale, R. & Etzkowitz, H. (2004) *The third academic revolution: polyvalent knowledge: the "DNA" of the Triple Helix*. Available at: [http://www.triplehelix5.com/files/thc5\\_themepaper.pdf](http://www.triplehelix5.com/files/thc5_themepaper.pdf). (Accessed August 25, 2009)
- [5] OECD (2007) *Higher Education and Regions, Globally Competitive, Locally Engaged*. OECD Publishing, Paris.

- [6] Carayannis, E. G., Alexander, J. & Ioannidis, A. (2000) 'Leveraging knowledge, learning, and innovation in forming strategic government-university-industry (GUI) R&D partnerships in the US, Germany, and France', *Technovation*, Vol. 20, pp.477-488
- [7] Larédo, P. & Mustar, P. (2001) *Research and Innovation Policies in the New Global Economy*. Edward Elgar Publishing, UK.
- [8] Göransson, B., Maharajh, R. & Schmoch, U. (2009) 'New activities of universities in transfer and extension: multiple requirements and manifold solutions', *Science and Public Policy*, Vol. 36 No. 2, pp.157-164
- [9] Dill, D. D. (1990) 'University/Industry research collaborations: an analysis of interorganizational relationships', *R&D Management*, Vol. 20 No. 2, pp.123-129
- [10] Liefner, I. & Schiller, D. (2008) 'Academic capabilities in developing countries-A conceptual framework with empirical illustrations from Thailand', *Research Policy*, Vol. 37, pp. 276-293
- [11] Leydesdorff, L. & Etzkowitz, H. (1996) 'Emergence of a triple helix of university-industry-government relations', *Science and Public Policy*, Vol. 23, pp. 279-286
- [12] Irawati, D. (2007) 'Strengthening cluster building in developing country alongside the triple helix: challenge for Indonesian clusters-a case study of the Java region', in: Paper Presented at the *DRUID Winter Conference*. 25-28 January 2007. Aalborg, Denmark. <http://mpira.ub.uni-muenchen.de/5831> (Accessed February 8, 2009).
- [13] Johnson, W. H. A. (2008) 'Roles, resources and benefits of intermediate organizations supporting triple helix collaborative R&D: The case of Precarn', *Technovation* Vol. 28, pp. 495-505
- [14] Marques, J.P.C., Caraca, J.M.G. & Diz, H. (2006) 'How can university-industry-government interactions change the innovation scenario in Portugal?—the case of the University of Coimbra', *Technovation*, Vol. 26, pp. 534-542
- [15] Ranga, L.M., Miedema, J. & Jorna, R. (2008) 'Enhancing the innovative capacity of small firms through triple helix interactions: challenges and opportunities', *Technology Analysis & Strategic Management*, Vol. 20 No. 6, pp. 697-716
- [16] Saad, M. (2004) 'Issues and challenges arising from the application of innovation strategies based on the triple helix culture: experience of incubation system in Algeria', *International Journal of Technology Management and Sustainable Development*, Vol. 3 No. 1, pp. 17-34
- [17] Brännback, M., Carsrud, A., Krueger, N. & Elfving, J. (2008) 'Challenging the Triple Helix model of regional innovation systems: A venture-centric model', *International Journal of Technoentrepreneurship*, Vol.1 No. 3, pp. 257-277
- [18] Etzkowitz, H., Dzisah, J., Ranga M. & Zhou, C. (2007) 'The triple helix model of innovation: university-industry-government interaction', *Tech Monitor*, Vol.1, pp. 14-23
- [19] Etzkowitz, H. & Leydesdorff, L. (2000) 'The dynamics of innovation: from National Systems and "Mode 2" to a Triple Helix of university-industry-government relations', *Research Policy* Vol. 29, pp. 109-123
- [20] Leydesdorff, L. (2003) 'A methodological perspective on the evaluation of the promotion of university-industry-government relations', *Small Business Economics*, Vol. 20, pp. 201-204
- [21] Inzelt, A. (2004) 'The evolution of university-industry-government relationships during transition' *Research Policy*, Vol. 23, pp. 975-995
- [22] Hadjimanolis, A. (2006) 'A case study of SME-university research collaboration in the context of a small peripheral country (Cyprus)', *International Journal of Innovation Management*, Vol. 10 No. 1, pp. 65-88
- [23] Taiwan Office of SBIR Program, 2008. Performance of SBIR program (in Chinese), <http://www.sbir.org.tw/SBIR/Web/Analysis.aspx>, (Accessed September 03, 2009).
- [24] Leong, B., Wee, A. K.S. & Ho, Y.P. (2008) 'Is an enterprise framework necessary for an entrepreneurial university? A comparison of technology start-up in Singapore and Sweden', *Science and Public Policy* Vol. 35 No. 9, pp. 647-656

[25] Razak, A.& Saad, M. (2007) 'The role of universities in the evolution of the Triple Helix culture of innovation network: The case of Malaysia', *International Journal of Technology Management and Sustainable Development* Vol. 6 No. 3, pp. 211-225

# Using System Dynamic Modeling to Assess the Effects of Feed-in Tariffs on Wind Power Installations

Pao-Long Chang, Chiung-Wen Hsu

Feng Chia University

E-mail [plchang@fcu.edu.tw](mailto:plchang@fcu.edu.tw), [cwenhsu@fcu.edu.tw](mailto:cwenhsu@fcu.edu.tw)

## Abstract

*The Taiwanese government adopts policies to achieve national CO<sub>2</sub> emission reduction targets. FITs are the most expensive policy for the Taiwanese government. Therefore, it is important to assess the effects of FITs on wind power installations. This study uses the system dynamics approach to develop a simulation model to assess the FITs policy. Decision makers can use this model to assess whether FITs can achieve the desired policy target, and ascertain the required policy cost needed to achieve the target. The simulation period is from 2013 to 2025. The results show that with the current FIT price of NT\$2.6258/kWh, the target of 1,200 MW will not be met as scheduled in 2020. If the FIT price is increased by 23.4% to NT\$3.24/kWh, the target can be achieved on time. However, when the policy target is successfully met, the average cost of emission reduction increases from NT\$4.61/kg CO<sub>2</sub> to NT\$5.613/kg CO<sub>2</sub>.*

## 1. Introduction

In order to mitigate global climate change, many nations have acknowledged the need for reducing carbon emissions and establishing an environment conducive to sustainable development. Governments have devised objectives and policies for enabling domestic energy conservation. In Taiwan, carbon emissions will reach 467 million tonnes by 2020 if energy conservation policies are not implemented. The government has set a goal of reducing emissions to the 2005 level of 257 million tonnes; thus, there must be a decrease of 210 million tonnes, or 45% [1]. Therefore, the government has planned a variety of policies, measures, and programs to achieve this reduction, and it is now necessary to assess the effectiveness of carbon emission reduction.

Wind energy is one of the cleanest energy resources, and it does not cause or add to global warming. It is often considered an alternative to fossil

fuels such as oil and coal. Therefore, many countries are actively promoting wind power. In the year 2011, 40.5 GW of wind power capacity was installed worldwide. By the end of that year, the total amount of wind power capacity installed at the global level reached 238 GW [2].

Taiwan is an island country that lies in the ocean east of Asia. It has abundant wind resources—land areas with an average wind speed exceeding 5 and 4 m/s are 2,070 and 8,046 km<sup>2</sup>, respectively. The potential installed on-land and off-shore wind power capacities are 1,667 and 7,400 MW, respectively [3,4]. By the end of 2012, Taiwan's cumulative installed on-land wind power capacity was approximately 560 MW. Before 2020, Taiwan will install approximately 450 additional wind turbines in order to increase the national cumulative installed wind power capacity to 1,200 MW, which is the target set by the government [5].

Taiwan's development of wind power started relatively late. In the year 2000, the government enacted the "Regulations Governing the Subsidy for Wind Power Demonstration System," which was replaced by the "Points Governing the Feed-in Tariffs for Renewable Energy" in 2003. Wind turbines installations executed by Taipower and the private sector have experienced rapid growth since 2005. Among these, the "Regulations Governing the Subsidy for Wind Power Demonstration System" promoted a 5-year wind power demonstration and promotion project with a maximum subsidy of NT\$16 million for each MW of wind power capacity installed. The subsidy ratio was limited to 50% of the installation cost of the project. These regulations were abolished in July, 2004. The cumulative installed capacity of wind power demonstration systems for which the subsidy had been reached stands at 8.54 MW. To promote the development of renewable energy generation technology, including wind power, the Taiwanese government promulgated the "Statutes Governing the

Development of Renewable Energy” on July 8, 2009 and the Ministry of Economic Affairs then proposed a new feed-in tariff (FIT) price for the next 20 years. According to the FIT publicized by the Ministry of Economic Affairs in 2013, the FIT price is set at NT\$7.3562 per kW-h for on-land installations with a capacity between 1 and 10 kW and at NT\$2.6258 per kW-h for on-land installations with a capacity above 10 kW. The FIT price is set at NT\$5.5626 per kW-h for all off-shore installations regardless of their capacities [6].

To facilitate the growth of Renewable Energy Sources (RES) application, some existing government instruments, such as fixed FIT, net metering, the bidding strategy process, quotas, green certificate trading, green power exchange, and green pricing have been introduced [7]. The advantages and disadvantages of the functionality of FITs and green certificates in liberalized electricity markets have been presented [8]. The discussion states that both FITs and green certificates can contribute to increasing the share of renewable generation. Menanteau [9] concludes that FITs are more efficient than a bidding system, but the performance of green certificates was influenced by market structures and market rules.

FITs have been the primary mechanism used for supporting RES development in both Europe and the United States. Until 2009, they were being applied in 20 EU member countries [10]. The German Renewable Energy Sources Act (Erneuerbare Energien Gesetz, EEG) with its FITs has been especially successful in promoting renewable energy technologies.

However, although policy tools such as FITs can provide incentives for the private sector to invest in wind power, the government needs to contribute huge amounts of money. Excessive policy costs not only impose a financial burden on the government, but also triggers people’s concern over the long-term adoption of such policy tools, which is detrimental to the promotion of wind power. Therefore, decision makers in the government must assess the effects of policy tools that are formulated to promote wind power to achieve the projected target of carbon emission reduction, including the achievement ratio of the targeted wind power installations and the cost effectiveness of carbon emission reduction.

Mitchell et al. [11] compared FITs and quotas, considering the correlation between risks to future generations or investors and policy effectiveness. They concluded that low risk shows high policy effectiveness and that the German FIT system provides higher security for investors than the Renewables Obligation of the UK. In Dutra and Szkio [12],

incentive mechanisms such as FITs and quotas were evaluated for wind power by applying a geographic information system model in Brazil. The target was to reduce the emissions of greenhouse gases. In Falconett and Nagasaka [13], a probabilistic model is developed to evaluate the net present value (NPV) of renewable energy projects under different support mechanisms such as government grants, FITs, and renewable energy certificates (RECs). The results showed that the FITs and green certificates are useful in promoting less mature renewable technologies and compatible technologies, respectively. A comparison of support schemes such as FITs, quotas, and auctions was implemented for market-based deployment of renewable energy in the UK and Germany [14].

However, most support mechanisms only consider a simple form of renewable energy promotion. Whereas other factors influence the installation of wind power: government policies, costs of wind turbines, wind power planning by state-owned power companies, business strategies, as well as maturity of technology [15–17]. Among these, the government is the major driver of wind power installations [8, 12, 14, 18]. Existing studies mainly focus on assessing the effects of policy implementation. Studies have not been devoted to predicting the effects of wind power installation before the policy implementation. Nevertheless, studying the effects before policy implementation will assist the government in formulating effective promotional policies, which should be an important research subject.

As a result, the primary purpose of this research is to construct an assessment model that can be used to analyze FITs as policy tools in promoting wind power to achieve the target of installed wind power capacity and carbon emission reduction. In this assessment model, a simulation system will be constructed to assess the effects of FITs on wind power installations and to analyze the achievement ratio of the projected policy target. In addition, this research examines Taiwan’s wind power and analyzes the effects of FITs on the installed wind power capacity as well as the achievement ratio of the policy target. Simultaneously, the optimal FIT price suitable to achieving the policy target can be obtained. The simulation system employed in this research will enable policymakers to assess the effects of FIT policy on wind power generation.

This article begins with a study of policy assessment methods and SD models. Next, a SD model of wind power generation installations is constructed; this includes a causal loop and a quantitative model. Then, the model is used to analyze and assess the

policy effects of FITs on wind power installations. Finally, conclusions and recommendations are provided.

## 2. Methods

The quantitative methods most often used to assess policy effectiveness include econometric models and cost-benefit analysis. Econometric models require sufficiently long-term data. Cost-benefit analysis requires the identification of the actual costs and benefits of policies implemented. However, good-quality data are frequently difficult to retrieve [19]. The methods described above emphasize the direct relationship between the parameters and effectiveness. This study is particularly concerned with the entire process of shift that is affected by policies.

In practice, the installation of wind power depends on numerous factors, which have a series of interactions. For example, increasing the FIT price will facilitate a higher return on investment (ROI) for wind farms. Increasing the return on investment for wind farms will attract investments in installed wind power capacity. Increasing the wind power capacity installed by the private sector will achieve the target of the installed wind power capacity. Achieving the target of the installed wind power capacity will decrease the FIT price. Therefore, these factors not only have feedback relationships but also causal relationships based on time dynamics.

System dynamics (SD) is an approach used to understand the behavior of a complex system as determined from its components. That is, a change in each component will affect the final behavior of the complex system. SD is a social system-related management concept developed by Jay W. Forrester at the Massachusetts Institute of Technology. The causal feedback of the system can be analyzed through dynamic systems thinking. Moreover, using computer simulations, the real influence of the social system on policy can be observed in the laboratory in order to understand the implied causal feedback in the system [20]. Therefore, a “policy laboratory” can be constructed using SD. This enables decision makers to simulate possible scenarios for different policies, and the results can be used to assist their decision-making.

SD is often used in organization management or policy analysis. For example, Gupta et al. [21] built a SD model in order to analyze the productivity of just-in-time systems. Bui and Loebbecke [22] built a decision support system using a SD model in order to forecast the supply and demand metrics for the mobile phone market. Naill [23] used SD to make projections

on energy policy in the United States in order to find ways to reduce the country’s dependence on foreign energy. In addition, many scholars have also found SD to be suitable for assessing energy savings and carbon dioxide emissions reductions [23,24]. Therefore, in this study, we adopt a SD method to construct a behavioral model and study the effects of FITs on wind power installations.

## 3. Model

### 3.1 Model Framework

The primary purpose of this research is to construct a SD model that simulates the change of the important indicators, such as the long-term installed wind power capacity, the amount of carbon emission reduction, as well as the government’s expenditure, through policy tool settings to assess the effects of the FITs as a policy tool, which is illustrated in the causal loop (Figure 1).

There are two types of policy tools that are used to promote wind power in Taiwan. The first is to encourage and attract the private sector to install wind power generators. The second is to require the public sector (Taipower) to execute wind power installations. Implementing FITs for wind power is the major policy scheme with respect to wind power installations made by the private sector. Therefore, the key is to increase the FITs for wind power. With the increase in FITs, companies will reap a higher return on investment. When the return on investment is increased, the installed wind power capacity will also increase. In other words, when the government implements the FIT scheme, the return on investment of wind farms will increase the projected privately installed wind power capacity. When the cumulative installed wind power capacity reaches the target set by the government, the FIT will be calculated based on the actual cost of power generation, which forms a negative feedback loop (Loop 1). Apart from this, when the cumulative installed wind power capacity fails to reach the target set by the government, the government will require the public sector (Taipower) to increase Taipower’s installed wind power capacity. This forms a negative feedback loop (Loop 2). At the same time, when the cumulative installed wind power capacity fails to reach the target set by the government, the private sector will also plan for additional wind power to increase installed wind power capacity by the private sector, which in turn increases privately cumulative installed wind power capacity. This forms a negative feedback loop (Loop 3).



After the private sector invests in wind power installations, the major source of income is from the FIT scheme implemented by the government through which the power generated from the wind power systems is sold to a power company designated by the government with a guaranteed long-term purchase price (usually for 20 years). The private power plants receive greater income and ROI with increasing quantity of power generated from the wind power systems (i.e., higher power generation capacity). The capacity refers to the average time of power generated at full capacity from each kW of the wind power installations each day in a given year. Power generation varies due to factors such as the location at which the wind system is installed, the method of installation, and the characteristics of the wind power installations. Moreover, the government's wind power FITs will increase because of the rising cost of wind turbines. The cost of wind turbines is affected by the rising international price of raw materials (such as steel).

In offering the FIT scheme, the government needs to incur expenditure to cover the wind power FITs. When the cumulative installed wind power capacity increases, the government's expenditure for FITs will rise accordingly. The expenditure on wind power FITs aimed at promoting wind power and the total amount of carbon emission reduction can be used to calculate the cost of carbon emission reduction (expenditure on the FITs per carbon emission reduction unit). When the expenditure on the FITs is increased, the cost of carbon emission reduction also rises. When carbon emission reduction increases, the cost of carbon emission reduction will decrease. When the government provides higher FITs to increase the installed wind power capacity of the private sector, power generated from fossil fuel will be replaced by wind power due to the rising installed wind power capacity in Taiwan, thus reducing carbon emissions and increasing the total amount of carbon emission reduction. However, higher FITs mean rising government expenditure on FITs. The rising expenditure on the FITs increases the average cost of carbon emission reduction under the wind power FIT scheme. Moreover, when the cost of wind turbines and the cost of operation increase, Taipower's installation cost will increase; this consequentially results in an increase in Taipower's average cost of carbon emission reduction. The total amount of carbon emission reduction is the sum of carbon emission reduction from both private wind farms and Taipower's wind farms.

Inside the causal loop of the entire system, the FITs are the driving force behind the continuing growth of

the installed wind power capacity by the private sector. Before the installed wind power capacity reaches the target, if the government increases the FITs, the return on investment will continue to rise, which will result in the continuous growth of the installed wind power capacity and policy expenditure. Therefore, when the installed wind power capacity reaches a certain level, the FITs should be reduced to the lowest power generation cost of the private wind farms. The annual growth of the installed wind power capacity will discontinue as well.

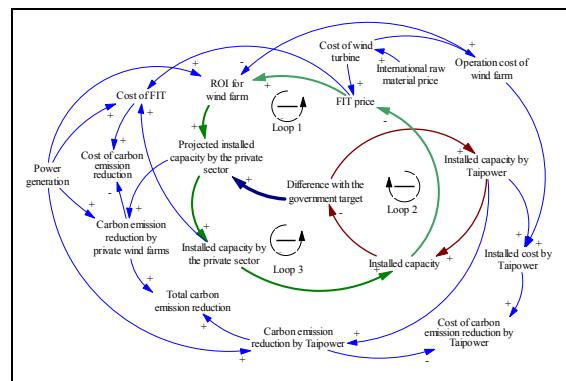


Figure 1: The causal relationship of wind power installation in Taiwan

### 3.2 Model flow diagram

The following is a simulation system of the installed wind power capacity and the amount of carbon emission reduction in Taiwan (Figure 2). It is constructed with the help of SD simulation software, Vensim (Vensim DSS for Windows Version 5.9c). The installed wind power capacity, carbon emission reduction, and expenditure on the FITs included the five levels of installation and wind power FITs and 22 formulas. Examples of the relationships between levels and significant variables are provided below.

#### 3.2.1. The cumulative installed wind power capacity.

In the simulation model, the cumulative installed wind power capacity is the sum of the cumulative amount of the annual installed capacity over the years (Equation 1 in the Appendix). The annual installed capacity is the sum of the annual installed wind power capacity by Taipower and the installation factor (Equation 2 in the Appendix). The installation factor herein refers to the annual installed wind power capacity by the private sector (annual) when the cumulative installed capacity fails to reach the target of 1,200 MW projected by the government (Equation 6 in the Appendix). When the cumulative installed capacity fails to reach 1,200 MW,



Taipower needs to add new wind power capacity (Equations 3 and 4 in the Appendix). This means that Taipower will continue to add new wind power installations if the cumulative installed wind power capacity fails to meet the government's target. The assumption is made that the annual installed wind power capacity by the private sector is delayed for a year compared to the planned annual installed capacity (from decision to install, and from the completion of installation to operation). The annual installed capacity in 2006 was 49.8 MW (Equation 5 in the Appendix). When the cumulative installed capacity fails to meet the government's target, assuming the ROI of private wind farms is higher than 5%, private wind farms will install new capacity, and the annual installed capacity is in direct proportion to wind farms' ROI (Equation 7 in the Appendix). The ROI of wind farms is the product of annual power generation and the wind power FIT divided by the cost of operation of wind farms (Equation 8 in the Appendix).

**3.2.2. The cumulative carbon emission reduction by private wind farms.** In the simulation model, the cumulative carbon emission reduction by the private sector installing wind turbines is the cumulative amount of the annual carbon emission reductions by the private wind farms over the years (Equation 13 in the Appendix). The annual carbon emission reduction is in direct proportion to private wind farms' annual installed capacity, annual power generation, and the electricity emission factor. According to the investment evaluation made by wind farms and the FITs calculated by the Bureau of Energy [5], the average time of power generation at full capacity is 2,500 h. Thus, a wind turbine with the installed capacity of 1 MW can generate 2,500,000 kWh/y (2,500 h/y\*1,000 M) each year. The electricity emission factor is the average weight of CO<sub>2</sub> emitted from the generation of 1 kWh of electricity (kgCO<sub>2</sub>/kWh), which is based on the value of 0.536 kgCO<sub>2</sub>/kWh publicly announced by Taipower in 2012. The annual carbon emission reduction by private wind farms is the product of the annual power generation, the electricity emission factor, and the installation factor, which is then multiplied by the total amount of carbon emission reduction over the wind turbine's entire operation period (20 years) (Equation 14 in the Appendix).

**3.2.3. The cumulative carbon emission reduction by Taipower.** In the simulation model, the total carbon emission reduction by Taipower is the cumulative amount of the annual carbon emission reductions by Taipower's wind power installations over the years

(Equation 15 in the Appendix). The annual carbon emission reduction is in direct proportion to Taipower's annual installed capacity, annual power generation, and the electricity emission factor. According to the investment evaluation made by wind farms and the FITs calculated by the Bureau of Energy [5], the average time of power generation at full capacity is 2,500 h. Thus, a wind turbine with the installed capacity of 1 MW can generate 2,500,000 kWh/y (2,500 h/y\*1,000 M) each year. The electricity emission factor is the average weight of CO<sub>2</sub> emitted from the generation of 1 kWh of electricity (kgCO<sub>2</sub>/kWh), which is based on the value of 0.536 kgCO<sub>2</sub>/kWh publicly announced by Taipower in 2012. The annual carbon emission reduction by Taipower is the product of annual power generation and the electricity emission factor and Taipower's annual installed wind power capacity, which is then multiplied by the total amount of carbon emission reduction over the wind turbine's entire operation period (20 years) (Equation 16 in the Appendix).

**3.2.4. The cumulative expenditure on wind power FITs.** According to Taiwan's current wind power FIT scheme, each year the government will formulate a FIT price based on the cost of power generation. The FIT price will serve as the purchase price of electricity generated by the new operators that install wind power installations in the given year for the next 20 years. In the entire period of the simulation model, the government's expenditure on wind power FITs in a given year, which is intended to promote wind power installations, is calculated based on the following: the wind turbine has a lifetime of 20 years; the average time of power generation at full capacity is 2,500 h (according to the government's calculation of the FIT price); the average cost of capital is 5.25% [5]. Among these, the investment made by wind farms includes both the initial installation costs and annual operation and maintenance expenses. Assuming that the lowest cost of wind power generation (rate factor) is lower than the FIT for wind power and the cumulative installed wind power capacity has not reached the target set by the government, the government needs to formulate a preferential FIT for wind power, or alternatively, to use the lowest power generation cost of wind farms as the FIT for wind power (Equations 9 and 10 in the Appendix). In addition, if the cost of wind turbines is set at the current level, the cost will increase due to the rising international price of raw materials (Equation 12 in the Appendix). The value of the international price factor is calculated by taking the price of a wind turbine in a

given year [25] and dividing it by the price of a wind turbine in 2006.

The cumulative expenditure on wind power FITs is the cumulative amount of the annual expenditures on FITs over the years (Equation 17 in the Appendix). The annual expenditure on wind power FITs in a given year is the product of the annual power generation, the FIT for wind power, and the installation factor (Equation 18 in the Appendix). In this SD model, the expenditure on FITs for wind power is the government's total expenditure on the projected power generation by wind turbines for their years of service (20 years), which operate at full capacity for 2,500 h each year. The average cost of carbon emission reduction under the FIT scheme is the cumulative expenditure on FITs for wind power divided by the cumulative amount of carbon emission reduction by private wind farms (Equation 19 in the Appendix).

**3.2.5. The cumulative installation cost of Taipower's wind farms.** Taipower's cumulative installation cost of wind farms is the cumulative amount of the annual incurred installation costs over the years (Equation 20 in the Appendix). The annual installation cost is the product of the cost of operation of the wind farm and Taipower's annual wind power capacity (Equation 21 in the Appendix). The cost of operation of the wind farm is in direct proportion to the cost of a wind turbine. It is assumed that the cost of a wind turbine is 75% of the initial cost of the wind farm, and the annual operation and maintenance cost of the wind farm are 1.5% of the cost of a wind turbine for a period of 20 years (Equation 11 in the Appendix). Taipower's average cost of carbon emission reduction is its cumulative installation cost divided by its cumulative carbon emission reduction (Equation 22 in the Appendix).

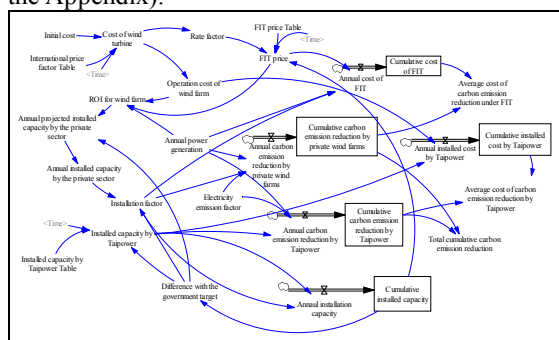


Figure 2: Dynamic process diagram of wind power installation in Taiwan

### 3.3 Model validation

Validation is a process intended to construct an accurate and credible model [26]. The reliability of a model is built upon structural and behavioral validity. Behavioral validity is meaningful only when the structure of the model is reliable [27]. Therefore, after the quantitative model was constructed in this research, the model was subsequently subject to a validity test in order to verify the reliability and the closeness between the behavior presented by the model and the real world.

Sterman has noted that a good model should present the same behavior observed from data [28], i.e., whether the behavior presented by the model is consistent with the real world. This research utilizes the historical data of the cumulative installed wind power capacity between 2005 and 2012 to verify the simulation results of the above SD model. A comparison between the simulated values of the cumulative installed wind power capacity and the historical values is presented in Figure 3. The simulated values between 2005 and 2012 are very close to the historical data. Therefore, the results of simulation are acceptable.

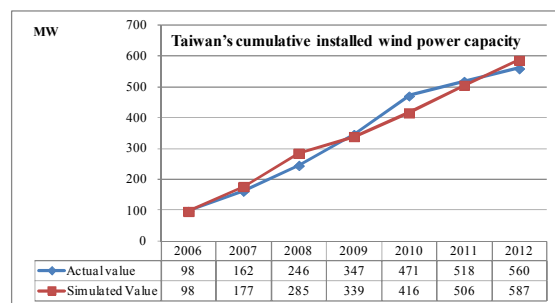


Figure 3: Simulated values of the cumulative installed wind power capacity and the historical values

## 4. Findings and discussion

The primary purpose of this research is to utilize the SD model to simulate the effects of a FIT on Taiwan's wind power installations, including the achievement ratio of the target and the effect on the cost of carbon emission reduction. The following is a simulation of Taiwan's installed wind power capacities under different FIT prices between 2013 and 2025. This simulation facilitates the understanding of the effects of the government's adoption of the FIT scheme on wind power installations. This research uses Taiwan's cumulative installed wind power capacity, the achievement ratio of the wind power target, the cumulative carbon emission reduction by wind farms,

and the average cost of carbon emission reduction under the FIT scheme as indicators.

#### 4.1 Simulation settings

Taiwan’s wind power application saw a relatively rapid growth between 2009 and 2012. By the end of 2012, the cumulative installed capacity already reached 560 MW. The total installed capacity of 638.5 MW in 2013 is obtained using SD simulation between 2006 and 2013, which is used as the initial cumulative installed capacity for the 2013–2025 simulation period. In addition, the average cost of a wind turbine is approximate NT\$46,100/kW in 2013 [25]. Simultaneously, the international price factor of the cost of a wind turbine is fixed at 1.04. The electricity emission factor improves with the improvement made by Taipower in power generation. It is assumed that the electricity emission factor decreases by 1% on a year-to-year basis. Table 1 lists all the parameter values used for system simulation.

Table 1: Parameter values for simulation between 2013 and 2025

Parameter	Parameter value
The initial cumulative installed capacity	638.5 MW (SD simulation)
The initial cost of a wind turbine	46,100 (NT/kW)
The electricity emission factor	Decreased by 1% on a year-to-year basis from 0.536 in 2013
The international price factor	Fixed at 1.04 each year between 2013 and 2025

To forecast the effects of FITs on the installed wind power capacity, this research makes the first assumption that Taipower has no new wind power capacity in the future. The research sets five simulated settings as follows: the FIT price of NT\$3.26285/kWh in 2013 is maintained as the Base Case. According to this, a 30% increase on top of the Base Case is Case A2; a 15% increase on top of the Base Case is Case A1, a 30% decrease from the Base Case is Case D2, and a 15% decrease from the Base Case is Case D1.

#### 4.2 The effects on the achievement ratio of the target

The government adopted the FIT scheme to encourage the private sector to install wind power turbines. The simulation model in this research

simulates the effects of the five FIT prices on the installed wind power capacity, respectively, which are illustrated in Figure 4. Under the Base Case scenario, the target capacity of 1,200 MW can only be achieved in 2023, while, in the Case A1 scenario the target can be achieved in 2021. In the Case A2 scenario, the target can be achieved by 2020. If the FIT price is reduced as in the Case D1 scenario, the target will not be achieved until 2027. In the Case D2 scenario, the target can finally be achieved in 2038. In terms of the effects of the FIT price on the achievement of the target, it can be concluded from the varying time spans required to achieve the target under the above five scenarios with different FIT prices that a lower FIT price will result in the delay of the scheduled time of target achievement.

Figure 4 illustrates the cumulative installed wind power capacities, which include capacities generated by both private wind farms and Taipower. With the implementation of the FIT scheme, the installed wind power capacity owned by private wind farms has grown. This increases the ratio of wind power generated by the private sector. For example, in the Base Case scenario, the installed wind power capacity owned by the private sector accounts for 58% of the total installed wind power capacity in 2013. This ratio will increase to 78% in 2025. It shows that the FIT scheme has been driving up privately generated wind power.

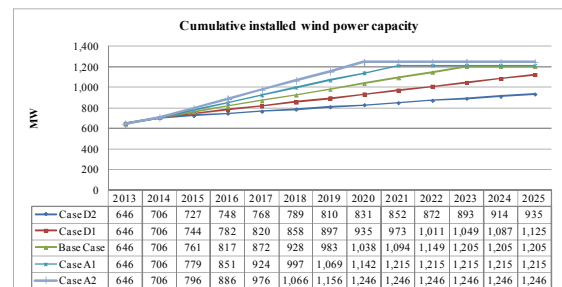


Figure 4: The effects of FITs on the cumulative installed capacity

Moreover, Figure 5 explains the relationship between the change of the FIT price and the scheduled time of target achievement. To use Base Case as the reference, an increase by 15% in the FIT price will lead to the successful achievement of the target goal 2 years ahead of the schedule. On the contrary, a decrease of 15% in the FIT price will lead to a 4-year delay. If the FIT price is raised by 30%, the target will be achieved 3 years ahead of the schedule while a reduction of 30% in the FIT price will lead to a 15-year delay. This phenomenon shows that an excessively low FIT price

is unlikely to attract the private sector to invest in wind power installations. The optimal FIT price of NT\$3.42/kWh is obtained via simulation. In other words, if the base FIT price is raised by 23.4%, the target of installed capacity will be achieved in 2020.

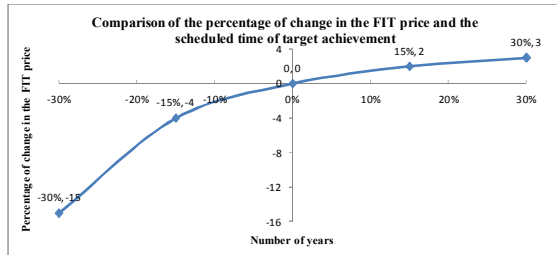


Figure 5: Comparison of the effects on the scheduled time of target achievement

### 4.3 The effects on the cumulative carbon emission reduction

According to our analysis of the effects of the FIT price on carbon emission reduction, the increase in the FIT price will result in an increase in the wind power capacity installed by the private sector, which will in turn increase carbon emission reduction. Figure 6 shows noticeable positive effects obtained via an analysis of the five scenarios. For example, the cumulative carbon emission reduction under the Base Case scenario reaches 11.8 million tons in 2020. Carbon emission will be reduced by 14.49 million tons in the Case A1 scenario while carbon emission will be reduced by 9.11 million tons in the Case D1 scenario. Although a higher FIT price will lead to more carbon emission reduction, the differences are minimizing after the target is achieved. For instance, the cumulative carbon emission reductions in Case A2, Case A1, and Base Case will be 17.18, 16.31, and 15.90 million tons, respectively, in 2025.

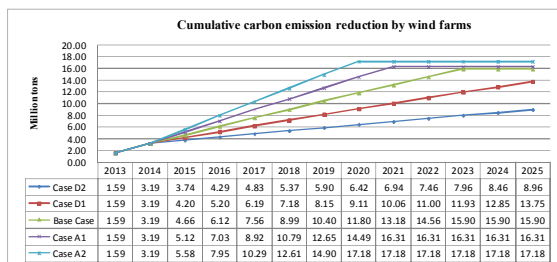


Figure 6: The effects of FITs on the cumulative carbon emission reduction

### 4.4 The effects on the cost of carbon emission reduction

Across the entire simulation period (2013–2025), a lower FIT price will achieve lower average cost of carbon emission reduction under the FIT scheme. For example, the wind farms' average costs of carbon emission reduction in Case D1, Base Case, and Case A1 will be NT\$3.53, NT\$4.36, and NT\$5.17 NT/kg CO<sub>2</sub> in 2020. After the cumulative installed wind power capacity reaches the government's target (1,200 MW), the annual installed wind power capacity will decrease, and the average cost of carbon emission reduction remains the same. For instance, the wind farms' average cost of carbon emission reduction is maintained at NT\$4.61/kg CO<sub>2</sub> between 2023 and 2025 (Figure 7).

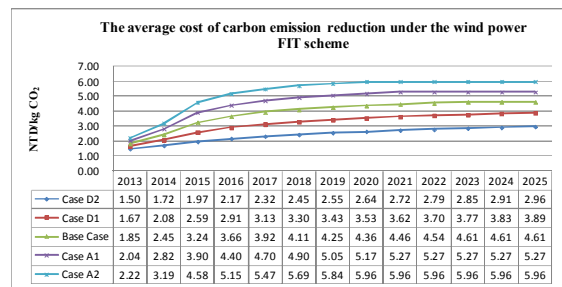


Figure 7: The effects of FITs on the average cost of carbon emission reduction

### 4.5 Comparison and analysis of carbon emission reduction and policy cost

Table 2 is a comparison of the different scenarios. In 2025, the average cost of carbon emission reduction in a particular policy scenario will be obtained by dividing the expenditure on FITs by the cumulative carbon emission reduction. To maintain the FIT price in the Base Case as in 2013, the reduction of the FIT price by 30% in Case D2 will result in an average cost of carbon emission reduction of NT\$2.96/kgCO<sub>2</sub>. However, the cumulative carbon emission reduction will decrease by 44%. Similarly, the reduction of the FIT price by 15% in Case D1 will result in an average cost of carbon emission reduction of NT\$3.89/kgCO<sub>2</sub> with the cumulative carbon emission reduction dropping by 14%. In contrast, if the FIT price is increased by 30% in Case A2, the average cost of carbon emission reduction will stand at NT\$5.96/kgCO<sub>2</sub> with an increase of 8% in the cumulative carbon emission reduction. Similarly, a 15% increase in the FIT price will lead to an average cost of carbon emission reduction of NT\$5.27/kgCO<sub>2</sub>

and the cumulative carbon emission reduction will increase by 3%. As a result, under the current FIT, the average cost (as well as the cumulative) of carbon emission reduction falls in proportion to the reduction in the FIT price. The cost of carbon emission reduction will be higher with an increase in the FIT price. Simultaneously, the rate of increase in the cumulative carbon emission reduction will be lessened.

Table 2: Comparison of the effects of FITs on carbon emission reduction in 2025

Scenario	Expenditure on wind power FITs (NT\$ billion)	Cumulative carbon emission reduction (Million tons)	Average cost of carbon emission reduction (NT/kg CO <sub>2</sub> )
Case D2	26.52	8.96	2.96
Case D1	53.46	13.75	3.89
Base Case	73.34	15.90	4.61
Case A1	85.90	16.31	5.27
Case A2	102.46	17.18	5.96

## 5. Conclusion and recommendations

This research adopts the SD method to construct a behavioral model on wind power installations, which can assist the government in assessing the effects of FITs on wind power installations. The research findings show that the FIT scheme has positive effects on the growth of Taiwan's installed wind power capacity. Moreover, by using the current FIT price, the projected target by the government will be achieved in 2023, three years later than the scheduled time of achievement. This shows that a simulation model can help decision makers to understand and assess the gap between the implemented policy and the attainment of the policy goal, and it can further serve as a reference for decision makers to adjust their policy.

According to the policy scenarios in this research, when the FIT increases by 23.4% to NT\$3.24/kWh, the target will be achieved in 2020. Although a lower wind power FIT will lead to a lower average cost of carbon emission reduction across the entire simulation period, the projected cumulative carbon emission reduction will be realized later, which will fail to satisfy the scheduled time of target achievement.

The contribution of this research is to systematically describe and quantify the causal relationships of Taiwan's wind power installation behavior through a SD model, and to simulate the effects of different FITs on wind power installations. This is the first ever simulation system in wind power installation of its kind in Taiwan, and it can also be modified to assess the effects of other renewable energy policies.

## Appendix Dynamic Equation

term	Parameter	Equation
	Cumulative installed capacity (MW)	= INTEG (Annual installed capacity)
	Annual installed capacity (MW)	= Annual installed capacity by Taipower + Installation factor
	Annual installed capacity by Taipower (MW)	= IF THEN ELSE (Difference from the government target >0, Annual installed capacity by Taipower table (Time), 0)
	Difference with the government target (MW)	= IF THEN ELSE (Cumulated installed capacity >1200, 0, (1200-Cumulated installed capacity))
	Annual installed capacity by the private sector (MW)	= DELAY FIXED (Annual projected installed capacity by the private sector, 1, 49.8)
	Installation factor	= IF THEN ELSE (Difference with the government target =0, 0, Annual installed capacity by the private sector)
	Annual projected installed capacity by the private sector (MW)	= IF THEN ELSE (Difference from the government target >0, IF THEN ELSE (ROI for wind farm >0.05, (ROI for wind farm -0.045)/0.045*60,0),0)
	ROI for wind farm	= Annual power generation*1000*FIT price/Operation cost of wind farm

	FIT price (NT\$/kWh)	= IF THEN ELSE (Rate factor < FIT price table (Time), IF THEN ELSE (Cumulated installed capacity < 1200, FIT price table (Time), Rate factor /1.04), Rate factor)
0	Rate factor	= (Cost of wind turbine / 1000 * (1.33 + 0.015)) / 20 / 2500
1	Operation cost of wind farm (NT/MW)	= Cost of wind turbine * 1.33 + Cost of wind turbine * 0.015 * 20
2	Cost of wind turbine (NT/MW)	= International price factor table (Time)* Initial cost *1000
3	Cumulative carbon emission reduction by private wind farms (1,000 tons)	= INTEG (Annual carbon emission reduction by private wind farms)
4	Annual carbon emission reduction by private wind farms (1,000 tons)	= Annual power generation * Electricity emission factor * Installation factor * 20
5	Cumulative carbon emission reduction by Taipower (1,000 tons)	= INTEG (Annual carbon emission reduction by Taipower)
6	Annual carbon emission reduction by Taipower (1,000 tons)	= Annual power generation * Electricity emission factor * Annual installed capacity by Taipower * 20
7	Cumulative cost of FIT (NTD)	= INTEG (Annual cost of FIT)
8	Annual cost of FIT (NTD)	= Annual power generation * FIT price * Installation factor * 1000 * 20
9	Average cost of carbon	= Cumulative cost of FIT/Cumulative carbon emission reduction by

	emission reduction under FIT (NTD)	private wind farms /1000
0	Cumulative installed cost by Taipower (NTD)	= INTEG (Annual installed cost by Taipower)
1	Annual installed cost by Taipower (NTD)	= Operation cost of wind farm * Annual installed capacity by Taipower
2	Average cost of carbon emission reduction by Taipower (NTD)	= Cumulative installed cost by Taipower /Cumulative carbon emission reduction by Taipower

2006–2012 parameter values

Item	Parameter	Value
	Cumulative installed capacity (MW)	= 97.5
	Annual power generation (kWh)	= 2,500
	Initial cost (NT/kW) [Note1]	= 43,000
	Cumulative carbon emission reduction by Taipower (1,000 tons)	= 0.536 * 30 * Annual power generation * 20
	Electricity emission factor (kg/kWh)	= 0.536
	Cumulative carbon emission reduction by private wind farms (1,000 tons)	= 0.536 * 49.8 * Annual power generation * 20
	Cumulative cost of FIT (NTD) [Note 2]	= 49.8 * 2.18 * 20 * Annual power generation
	Cumulative installed cost by Taipower [Note 3]	= 30 * 7.364e+007

Note 1: The initial cost is NT\$43,000 in 2006. (The reference cost of a FIT announced by the Bureau of Energy in 2009 was NT\$55,000/kW; the international price factor in 2009 was 1.28. Therefore, the initial cost in 2006 = NT\$55,000 / 1.28 = NT\$43,000.)

Note 2: The initial value of the cumulative cost on FITs is  $49.8 * 2500 * 2.18 * 20$ . The value 2.18 is used to simulate the wind power FIT in 2006 (first year); 49.8 is used to simulate the installed capacity in 2006 (first year).

Note 3: The initial cost of the cumulative installation of Taipower's wind farms is  $30 * 7.364e + 007$ . The value 30 is used to simulate Taipower's new capacity in 2006 (first year); 73,640,000 is used to simulate the total cost of each MW of a wind farm in 2006 (first year) (including installation and operation).

## References

- [1] C.Y. Liang, "Strength domestic present energy saving policies", September 2, 2010. Retrieved 12/16/2010 World Wide Web, <http://www.pcc.gov.tw/>.
- [2] Global Wind Report-Annual market update 2011, Global Wind Energy Council, [http://www.gwec.net/fileadmin/documents/NewsDocuments/Annual\\_report\\_2011\\_lowres.pdf](http://www.gwec.net/fileadmin/documents/NewsDocuments/Annual_report_2011_lowres.pdf)
- [3] C.D. Yue, C.M. Liu, and M.L. Liou, "A transition toward a sustainable energy future: feasibility assessment and development strategies of wind power in Taiwan", *Energy Policy* 29 (2001), pp. 951-963.
- [4] Z.W. Yan, "The discussions of offshore wind power industry development strategy and related industry development", ITRI, 2012.12.18. <http://www.ctci.org.tw/public/Attachment/311016922155.pdf> [accessed on 10.02.2012].
- [5] MOEA, The 2013 feed-in tariffs for renewable energy and the calculation formulas, [http://web3.moeaboe.gov.tw/ECW/populace/content/Content.aspx?menu\\_id=1955](http://web3.moeaboe.gov.tw/ECW/populace/content/Content.aspx?menu_id=1955) [accessed on 10.04.2012].
- [6] C.J. Ou, "Thousand wind turbines in action – from on-land to off-shore", *Energy Policy*, September 2011, pp. 26-33.
- [7] T. Ackermann, G. Andersson, and L. Soder, "Overview of government and market driven programs for the promotion of renewable power generation", *Journal of Renewable Energy* 22 (2001), pp. 197–204.
- [8] M. Ringel, "Fostering the use of renewable energies in the European Union: the race between feed-in tariffs and green certificates", *Journal of Renewable Energy* 31 (2006), pp. 1–17.
- [9] P. Menanteau, D. Finon, and M. Lamy, "Prices versus quantities: choosing policies for promoting the development of renewable energy", *Journal of Energy Policy* 31 (2003), pp. 799–812.
- [10] Campoccia, L. Dusonchet, E. Telaretti, and G. Zizzo, "Comparative analysis of different supporting measures for the production of electrical energy by solar PV and Wind systems: Four representative European cases", *Solar Energy* 83 (2009), pp. 287–97.
- [11] Mitchell, D. Banknecht, and P.M. Connor, "Effectiveness through risk reduction: a comparison of the renewable obligation in England and Wales and the feed-in system in Germany", *Journal of Energy Policy* 34 (2006), pp. 297-305.
- [12] R. Dutra and A. Szklo, "Assessing long-term incentive programs for implementing wind power in Brazil using GIS rule-based methods", *Journal of Renewable Energy* 33(2008), pp.2507–15.
- [13] Falconett I and K. Nagasaka, "Comparative analysis of support mechanisms for renewable energy technologies using probability distributions", *Journal of Renewable Energy* 35(2010), pp.1135-44.
- [14] L. Butler and K. Neuhoff, "Comparison of feed-in tariff, quota and auction mechanisms to support wind power development", *Journal of Renewable Energy* 33 (2008), pp. 1854–67.
- [15] L.Q. Liu and Z.X. Wang, "The development and application practice of wind-solar energy hybrid generation systems in China", *Renewable and Sustainable Energy Reviews* 13 (2009), pp. 1504-1512.
- [16] C.J. Lin, O.S. Yu, C.L. Chang, Y.H. Liu, T.F. Chuang, and Y.L. Lin, "Challenges of wind farms connection to future power system in Taiwan," *Renewable Energy* 34(2009), pp. 1923-1930.
- [17] L. Soder, L. Hofmann, A. Orths, H. Holttinen, Y.H. Wan, and A. Tuohy, "Experience from wind integration in some high penetration area", *IEEE Transaction on Energy Conversion* 22 (2007), pp. 4-12.



- [18] T. Couture T and Y. Gagnon, "An analysis of feed-in tariff remuneration models: implications for renewable energy investment," *Journal of Energy Policy* 38(2010), pp. 955-65.
- [19] J.E. Anderson, *Public policymaking*, 2000, Boston: Houghton Mifflin Company.
- [20] J. Buongiorno, "Forest sector modeling: a synthesis of econometrics, mathematical programming, and system dynamics methods", *International Journal of Forecasting* 12 (1996), pp. 329-343.
- [21] Y.P. Gupta, M.C. Gupta, and C.R. Bector, "A review of scheduling rules in flexible manufacturing systems", *International Journal of Computer Integrated Manufacturing* 2(1989), pp. 356-377.
- [22] T. Bui and C. Loebbecke, "Supporting cognitive feedback using system dynamics: a demand model of the global system of mobile telecommunication", *Decision Support Systems* 17(1996), pp. 83-98.
- [23] R. Naill, "A system dynamics model for national energy policy planning", *System Dynamics Review* 8(1992), pp. 1-19.
- [24] Ford, "Using simulation for policy evaluation in the electric utility industry", *Simulation* 40(1983), pp. 85-92.
- [25] Renewable energy technologies: Cost analysis series, volume 1: Power Sector 5/5 Wind Power, *International Renewable Energy Agency*, June 2012, p.20.
- [26] K.W. Yeh, Across age: Cross-licencing lighting become spindle, *Investment report of Yuanta Investment Consulting*, 2010.
- [27] J.W. Forrester and P.M. Senge, "Test for building confidence in system dynamics models", *TIMS studies in the management sciences* 14(1980), pp. 209-228.
- [28] J.D. Sterman, *Business dynamics: system thinking and modeling for a complex world*, 2000, McGraw-Hill, United State of America.

# Tourism destination image and travel risks of tourists from the Chinese Mainland to Taiwan

Chin-Tsai Lin, Shih-Chieh Hsu

Graduate School of Management, Ming Chuan University<sup>1</sup>, Department of Tourism Management, Ta Hwa University of Science and Technology<sup>2</sup>  
[ctlm@mail.mcu.edu.tw](mailto:ctlm@mail.mcu.edu.tw), [celt@ms23.hinet.net](mailto:celt@ms23.hinet.net)

## Abstract

*The Chinese Mainland tourists was the largest number of mobile populations in Asian countries and areas, with the sustained rapid growth of economy and outbound tourism, the world's largest outbound tourism market is formed in China. Significantly, the number of tourists from the Chinese Mainland to Taiwan has exceeded 7.3 million people in recent 5 years. This may have progressed by leaps and bounds, not only attracts the attention of neighboring Asian countries, but also as towards enthusiastically waving to the world tourism market. However, what factors exert an influence onto their visiting Taiwan is still unclear. In order to fill this gap, the present study is focused on causal model by establishing relationship of travel risks with related marketing constructs such as tourism destination image, travel motivation, and travel decision. It also aims to identify perceive of travel risks from Chinese Mainland tourists' concerns and explore whether such factors affect their travel decisions.*

**Keywords:** Chinese Mainland tourists; tourism destination image; travel risk

## 1. Introduction

The importance of the tourist destination's image is universally acknowledged, since it affects the individual's subjective perception and consequent behavior and destination choice [1][2][3][4]. Because of the subjective cognition to judge risk attributes and lack of knowledge about the tourism destination, most consumers often try to avoid negative experiences, consumers feel uncertain in purchasing travel-related products and cannot be assured with their expenditure results[5], the outcome of the consumption decision on travel-related products only can be evaluated thoroughly after their purchase, which adds more risks and ambiguous factors to their decision-making[6]. To

some degree, consumers perceive that they cannot complete their travel purchase process because of risk cognition [7]. Therefore, the risk cognitive has an intuitive appeal, and it is persuasive in explaining consumers' decision [8].

Destination image has been generally accepted in the literature that has influence on tourist behaviors[9][10][11]. A destination image is generally in terms of three sets of criteria, based on (1) regulatory framework, (2) business environment and infrastructure and (3) human, cultural and natural resources [12]. As the tourism marketplace is becoming more highly competitive, destination marketers have had to turn to branding to distinguish their destinations to convey a positive image that will motivate tourists to visit them[13]. Taiwan's special geographic environment and changeable climate combine to give it many unique and beautiful types of scenery, which are valuable natural sightseeing resources. Significantly, with the sustained rapid growth of economy, the unprecedented growth in China tourism industry during the last several decades has created major market. The Chinese Mainland tourists was the largest number of mobile populations in Asian countries and areas, in recent 5 years, the number of tourists to Taiwan has exceeded 7.3 million people. On the other hand, Taiwan tourism has selected 10 distinctive townships and city districts with tourism appeal, visitor-friendly environments, and other qualities suited for international marketing, with future promotions focused on encouraging visitors to experience in-depth Taiwan's small town charm.

The aim of this paper is to obtain a better understanding of the Chinese Mainland tourists' concerns and explore whether such factors affect their travel decisions. Through the causal analysis model to identify the travel risks and tourism destination image, and then offer the travel agency the strategies of increasing consumers' travel willingness among the attributions and dimensions with various decision-

making cognitions. These conceptual perspectives provide new insights into the determinants of types of tourism travel (especially individual versus package) and how tourists respond to particular hazards.

## 2. Literature review

### 2.1. The effects of travel risk

The intangibility, inseparability, heterogeneity and perishability of tourism products make it particularly difficult to assess risks [14], and risks are complex concepts. Reisinger and Mavondo (2005) stated risk involves exposure to the chance of injury or loss, a hazard or dangerous chance [15]. It indicated a nondeterministic outcome, with either positive or negative consequences. Chang (2009) indicated risks are a lack of knowledge about the tourism destination especially compared to usual place of residence, and lack of knowledge of future conditions, ranging from the weather to extreme natural or societal hazards [5].

[20] Ryan (1996) proposed there had significant between package tourists and individual drifter tourists in terms of their socio-demographic characteristics had significant differences perspective. [21] Simpson and Sigua (2008) found a correlations in tourism, not between education and risk, but between income and perceptions of crime, transportation, and financial risks. Hales and Shams (1991) and Lepp and Gibson (2003) present positive relationships between travel experience and preference for riskier destinations [8] [18]. Moreover, many studies have examined the relationships between age and risk, younger people had less risk cognitive and more tolerant than elder ones. [19] [20] [21]

Pearce (1982) used multidimensional scaling to demonstrate that tourists' motivation could be differentiated in terms of familiarity versus novelty seeking [22]. Yiannakis and Gibson (1992) used more multi-layered constructs relating to novelty motivation [23], and the most important study was Lepp and Gibson's (2003) which explicitly argued that, in international tourism, the cognitive of risk is directly related to preferences for familiarity versus novelty motivation [18]. However, amongst both organized mass tourists and drifters, Williams and Baláz (2013) noted that the more experienced tourists were also more likely to consider cultural barriers to be important risks [21]. Thus we propose the first hypothesis, as follows:

Hypothesis 1. Travel risk is positively associated with travel motivation.

Kozaket *al.*, (2007) reviewed the contribution of risk cognitive to destination image formation and

decisions to visit/avoid particular destinations [24]. This study proposes that a travel risks for tourism destinations are important, and the consideration of travel risks in the context of destination image suggests that it may influence the image of a destination depending on the travel risks that is conveyed, the lower travel risks will increase positive perceptions of an image toward a destination, thus, tourist image of a destination is an important factor responsible for its popularity and that identification of the different attributes of the image might provide important information that can be used in developing promotion strategies [25]. Based on this rationale, the following hypothesis is predicted:

Hypothesis 2. Travel risk is positively associated with destination image.

In the decision model, travel risk incorporates the primary dimensions of uncertainty and dissatisfaction, but what risk cognitive emphasizes is not a real risk that one can feel or receive. Bauer (1960) strongly emphasized that he was concerned only with subjective (perceived) risk and was not real world (objective) risk [26]. Lo and Lam (2004) found that personal safety (and implicitly risk) was an important determinant of participation in package tourism [27]. Williams and Baláz (2013) addressed risk and uncertainty issues which feature increasingly prominently in tourist decision making and behavior [21], and how tourism experiences influence risk perceptions and affect the destination choices made by tourists [28] [29]. While travel and tourism have always involved risk, there has been an increasing awareness of risks associated with natural and societal-originating disasters [30] [31]. Knight (1921) pointed that the difference between risk and uncertainty, that is the difference between known and unknown risks [32]. Williams and Baláz (2013) also analyzed the relationships between individual risk cognitive and tourist decision making [21]. Moreover, Silva *et al.*, (2010) draw influence from risks both the destinations that individuals choose not to visit, and those that they consider safe destinations [33]. Based on this rationale, the following hypothesis is proposed:

Hypothesis 3. Travel risk is positively associated with travel decision.

### 2.2. The effects of destination image

Image can be referred as the sum of beliefs, ideas, and impression that people holds about a place or destination [34] [35]. Destination image, could be vague or clear, can form in consumer mind without actual visitation [36], and it is of high significance because

image has direct impact on travel behavior as the most popular destination are those with positive image in the tourist mind [37]. The image of a destination can be defined as the perceptions of a place as reflected by the associations held in a tourist's memory [38][12]. Many studies have defined tourism image as an individual's overall perception by the strengths of a destination [39][40], and it is formed through a consistent information circulation between the destination and the tourists' home country [41].

Tourism has many potential physical and mental benefits, and in many studies it has been found that relaxation needs are a major motivation for holidaying [23]. Destination image is a key determinant influencing tourists' attitudes and motivation toward the destination [42][43]. Regarding the causal relationship between destination image and travel motivation, therefore, it is expected that a more favorable destination image will lead to a stronger perception attachment to travel a destination. Destination image and destination personality have positive effects on the tourist-destination relationship, which in turn affect tourist behavior [44]. Based on this rationale, the following hypothesis is proposed:

Hypothesis 4. Destination image is positively associated with travel motivation.

There have been numerous studies in the past, which suggested that destination image and associated specific destination attributes are the most influential factors in tourists' decision-making and affect tourists' behavior [45][46][47][48]. It has been generally accepted in the literature that destination image has influence on tourist behaviors [40][10][11]. The destination image is a key concept related to understanding tourists' destination decision processes [34][49], and destination image can influence travel decisions and toward to a destination. In the destination choice process, images are formed in relation to the motivations in a conscious or unconscious way [50]. Therefore, the following hypotheses are proposed:

Hypothesis 5. Destination image is positively associated with travel decisions.

### **2.3. The effects of travel motivation**

People engage in tourism behavior for different purposes or motives. Behind all actions, motivation is the central concept in understanding tourism behavior and the destination choice process [51][52]. Tourism researchers have long recognized the importance of studying reasons for travel, motivations, and attitudes toward tourism destinations to better understand and

predict travel decisions and consumption behavior of tourists. An improved understanding of travel motivations would help in segmenting the markets, thereby allowing tourism marketers to allocate scarce tourism resources more efficiently [53]. Crompton and McKay (1997) proposed three reasons to understand the importance of motivations: (1) understanding tourist travel motivations would create better products and services, (2) satisfaction with tourism experiences is essentially related to tourists' initial motives, and (3) before understanding tourists' decision-making processes, a destination marketer must be identified and prioritized tourist motives first [54]. Furthermore, delineation of underlying tourist motivations offer useful insights into understanding the destination selection decision-processes [35]. Based on this rationale, the following hypothesis is proposed:

Hypothesis 6. Travel motivation is positively associated with travel decisions.

## **3. Research Method**

### **3.1. Research site**

The Chinese Mainland tourists visiting Taiwan are targeted in this study. Taiwan lies off the southeastern coast of mainland Asia, across the Taiwan Strait from China, an island on the western edge of the Pacific Ocean, is one of the most important archaeological sites in Far-East Asia. To the north is Japan; to the south is Philippines. Many airlines fly to Taiwan, making it the perfect travel destination. They boast a number of high-profile attractions, such as Sun Moon Lake, Alishan, Kenting, Taroko Gorge National Park, the National Palace and the international landmark Taipei 101 building. Four tourist spots were chosen for study sites, i.e., the National Palace, National Dr. Sun Yat-sen Memorial Hall, Shilin Official Residence and Taipei 101 building.

### **3.2. Participants and procedure**

Applying the convenience sampling technique [55] and self-administered questionnaire method in order to distribute questionnaires to Chinese Mainland tourists at above research site during the month of April 2012, a total of 450 questionnaires were distributed and 410 usable responses were obtained, yielding a response rate of 91.1%. There were slightly more male respondents (233 respondents = 56.87%) than female ones. Sixty percent of respondents were married and 68.7% were aged older than 40 years old. Among the respondents, 75.1% held a college/university and higher degree, 57.8% of the respondents were

employed, and only 13.2% were students. Fifty eight percent of the respondents were from 4 municipalities, also translated as Direct-controlled municipality, such as Beijing, Shanghai, Tianjin and Chongqing cities. Most of the respondents to Taiwan were attending Group inclusive package tour (72.2%), and almost 73% were staying over than five days

### 3.3. Conceptual model and hypotheses

Drawing on the above literature and hypotheses development, the research model for this study is shown in Fig. 1. Overall, the present model is expected to contribute to an understanding of how travel risk and destination image influence Chinese Mainland tourists perceptions regarding both travel motivation and travel decision.

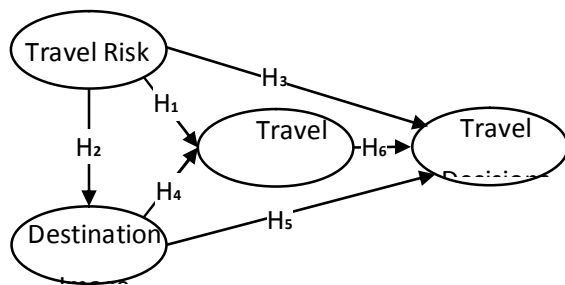


Fig. 1. Proposed framework

### 3.4. Data analysis

There are many statistical methods to test mediation effects, such as hierarchical regression [56] and structural equation modeling (SEM) technique [57]. Ro (2012) reported that out of a total of 572 refereed articles from the International Journal of Hospitality Management (IJHM), 75 percent of the mediation hypotheses were tested using SEM, indicating it to be the preferred method [58]. The relationships among travel risk, destination image, travel motivation and travel decision were empirically tested using SEM technique with AMOS 18 and SPSS with 17.0 as the tools of data analysis. A questionnaire was designed as the survey instrument to collect data for all the constructs in the proposed model. Items were measured with a five-point Likert-type scale, ranging from 'strongly disagree (=1)' to 'strongly agree (=5)'.

## 4. Empirical results

### 4.1. Reliability and validity testing

Based on the results of confirmatory factor analysis (CFA) and modification index of indicator variables [59] (Jöreskog and Sörbom, 1986), questionnaire items have a factor loading of 0.65 and above [57], one item of travel decision was dropped (TD 1 = 0.436) in this study (as shown in Table 1). To ensure the reliability and validity of the measurement, Cronbach's  $\alpha$  was used to conduct the reliability analysis, the value of Cronbach's  $\alpha$  should be at least 0.7 [60], also Average of Variances Extracted (AVE) and composite reliability (CR) as the basis to estimate the convergent validity [57]. A dimension with a CR value of higher than 0.7 and an AVE value of over 0.5 would be considered to have high convergent validity [61] [57]. As shown in Table 1, all dimensions have Cronbach's  $\alpha$ , AVE and CR value that are higher than the aforementioned cutoff values which indicate high reliability and good convergent validity. Afterwards on the diagonal we insert the AVE value in order to compare it with the other correlation coefficient in Table 2, and all AVE estimates from Table 1 can be seen to be greater than the corresponding inter-construct square correlation coefficients estimates.

Table 1 Reliability analysis and convergent validity.

Variable	Scale item	Factor loading	S Cronbach's $\alpha$	C.R	AVE
Travel Risk	T 1	0.753	0.566	0.870	0.695
	T 2	0.885	.784		
	T 3	0.858	.736		
	D 1	0.851	.724		
Destination Image	DI 1	0.937	.878	0.827	0.699
	DI 2	0.704	.496		
	DI 3	0.763	.582		
Travel Motivation	M 1	0.838	.702	0.736	0.843
	M 2	0.752	.566		
	TM 3	0.846	.715		
Travel Decisions	T 1	0.436	.190	0.736	0.843
	D 2	0.846	.715		
	TD 3	0.839	.704		

Note: SMC, Square multiple correlations; CR, Composite reliability; AVE, Average of variance extracted.

**Table 2** Correlation matrix of research constructs.

	Mean	Std. D	1	2	3	4
1.	3.9	0.7	<b>0.6</b>			
TR	7.5		<b>0.6</b>	<b>0.6</b>		
2.	4.1	0.6	0.28**	<b>0.99</b>		
DI	2.7		0.05**	0.87**	<b>0.85</b>	
3.	4.0	0.6	0.305**	0.287**	0.285	<b>0.7</b>
TM	9.6		0.505**	0.478**	0.228**	<b>0.8</b>
4.	3.3	1.1	0.35**	0.278**	0.228**	<b>0.43</b>
TD	3.7					

Note: TR, TravelRisk; DI, DestinationImage; TM, TravelMotivation; TD, Travel Decision.

**Table 3** Direct, indirect and total effects.

Path	Direct effect	Indirect effect	Total effect
<b>H1 : TR → TM</b>	0.61	0.35	0.97
<b>H2 : TR → DI</b>	0.50	-	0.50
<b>H3 : TR → TD</b>	0.26	0.51	0.77
<b>H4 : DI → TM</b>	0.70	-	0.70
<b>H5 : DI → TD</b>	0.33	0.25	0.58
<b>H6 : TM → TD</b>	0.35	-	0.35

Note: TR, TravelRisk; DI, DestinationImage; TM, TravelMotivation; TD, Travel Decision.

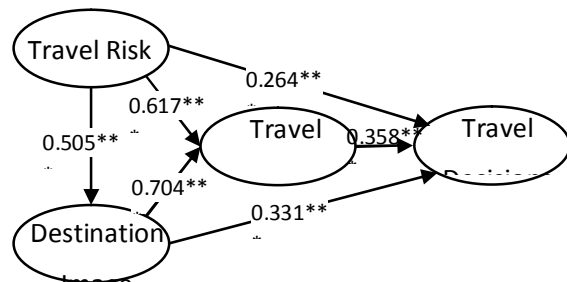
Table 3 reports the direct and indirect effects of all the variables. Travel risk has a direct effect on travel motivation, and both direct and indirect effects on destination satisfaction and destination trust. Destination personality has a direct effect on destination satisfaction, and both direct and indirect ones on destination trust. Regarding the constructs of the relationship, travel risk has both direct and indirect effects on travel decision, mediated by destination image and travel motivation. In terms of direct effects, travel motivation has a greater effect on travel decision (0.358) compared to travel risk (0.264)

and destination image (0.331). As for total effect, however, travel risk has the greatest effect on travel decision (0.779), in comparison with destination image (0.583) and travel motivation (0.358).

#### 4.2. Structural model and hypotheses testing

A maximum likelihood estimation method was used to test the predicted relationships among the constructs in the proposed conceptual model. The overall model fit indices were  $\chi^2(38) = 111.455$  ( $p = 0.000$ ),  $\chi^2/d.f. = 2.933$ , less than the criteria value of 3 suggested by [57]. Furthermore, other indicators of goodness-of-fit supported the very good fit of the model (such as GFI = 0.952, AGFI = 0.916, RMR = 0.032, RMSEA = 0.069, RFI = 0.936, NFI = 0.956, IFI = 0.97, and CFI = 0.97). This suggests that the hypothesized model fits the empirical data well.

As shown in Fig. 2, the estimated model with the standardized path coefficients and all the hypotheses are supported. Among the constructs within the relationship, travel risk is significantly and positively associated with travel motivation (0.617,  $t = 10.047$ ), destination image (0.505,  $t = 9.003$ ), and travel decision (0.264,  $t = 4.332$ ), thus supporting H1, H2, and H3. Destination image is significantly and positively associated with travel motivation (0.704,  $t = 12.351$ ), and travel decision (0.331,  $t = 6.164$ ), thus supporting H4 and H5. Travel motivation is significantly and positively associated with travel decision (0.358,  $t = 6.036$ ), providing support for H6. All three dimensions of the relationship are significantly and positively associated with travel decision. Accordingly, the path of tourists' cognitive knowledge (i.e. travel risk and destination image) and affective behavioral outcome (i.e. travel motivation and travel decision) is supported in this study.



**Fig. 2.** Proposed model with the path coefficients

## 5. Conclusions

Along with an increasing awareness of risk toward the importance of destination image, it is also important to know that tourists perceive destination image differently in terms of the destination attraction. The purpose of this study is to investigate the inter-relationships among travel risk, destination image, travel motivation and travel decision relationship within a Chinese Mainland tourists context, and to provide indicative findings for this segment of tourism. From the structural equation model it was found that travel risk not only has a positive direct effect relationship on destination image and travel motivation, but also has significantly direct and indirect effects relationship on travel decision relationship, and so supports [34][49]. Similarly, destination image also has a direct positive effect relationship on travel motivation, and both direct and indirect effects relationship on travel decision. Furthermore, travel motivation strongly mediates the relationship between travel risk, destination image and travel decision [42][43]. This implies that unless Chinese Mainland tourists understand the destinations, otherwise travel motivation is not guaranteed to create a travel decision between them.

The results reveal travel risk and destination image are the main components of Chinese Mainland tourists travelling to Taiwan, while travel motivation is the critical antecedent of this relationship, and travel decision is the outcome. Therefore, our findings show that emotional bonds or relationships do exist between Chinese Mainland tourists and Taiwan. However, given the pattern of results obtained it is suggested that the paper contributes to the literature in two ways. First it offers an insight into the Chinese Mainland tourists market for tourism and the factors that are in play for this market. Second, it suggests a series of items that appear to possess validity in creating measures for future study of the tourism market with reference to destination image, travel decision and risk cognitive.

Our results have important implications for travel authorities and tourism destination managers as well. Firstly, the percentage of the Chinese Mainland tourists searching for the relative travel information from mass media and magazines is quite high. If the travel authorities concerned can provide high positive destination image exposure and promotion channel, the travel decision can be increased. Similarly, tourism marketers are increasingly interested in finding

ways to develop strong destination image for Chinese Mainland tourists, which can lead to stronger travel motivation and travel decision [62][63]. Secondly, among the risk attributes, the most influential item is physical risk. Thus, through government issues tourism relative decree and effective management, connection and coordination with experienced consumers, providing them with the relevant information can reduce the degree of risk cognitive. In generally, consumers obtain travel information partly by word of mouth. Therefore, travel agents should deliver useful destination information, such as festival events, reasonable charges legal protection, and popular attractions, to stimulate consumers' travel motivation. Prayag and Ryan, (2011) also suggested that destination managers should take more into consideration the evolution of destination image and promotional messages [64], as well as advertising strategies for travel agents and tour guides by which they can proactively manage successful destination development.

## 6. Limitations and future research

This research is groundwork for forthcoming studies in the realm of inbound tourism development for Chinese Mainland tourists in Taiwan area. This study has several limitations. First, we only focus on four tourist destination, which may limit the generalizability of the findings. Second, this study employed a convenience sampling method, so the sample may not reflect the entire population of Chinese Mainland tourists to the research site. Third, any tourism initiative requires detailed consideration of issues like public-private agreement, interest of the locals, carrying capacity and environmental impacts were beyond the scope of this research.

In future research, the number of samples would be increased and extended to cover more Chinese Mainland tourists' contexts in different cultures, and replicating this study with other tourist destinations would increase our understanding of this important research concept. Moreover, the travel perceived risk model would attempt to theoretically stimulate the decision-making process of Chinese Mainland tourists.

## 7. Reference

[1] K.S. Chon, "Self-image/destination image congruity", *Annals of Tourism Research*, 19(2), 1992, pp. 360-363.



- [2] C.M. Echtner, and J. R. B. Ritchie, "The meaning and measurement of destination image", *The Journal of Tourism Studies*, 2(2), 1991, pp.2-12.
- [3] M.G. Gallarza, I.G.Saura, and H.C.García, "Destination Image: Towards a Conceptual Framework", *Annals of Tourism Research*, 29(1), 2002, pp. 56-78.
- [4] M.J. Stabler, "The Image of Destination Regions: Theoretical and Empirical aspects. In Nina K. Prebensen, Exploring Tourists' Images of a Distant Destination", 1988, pp.747-756.
- [5] S.Y.Chang, "Australians' holiday decisions in China: a study combining novelty-seeking and risk-perception behaviors", *Journal of China Tourism Research*, 5(4), 2009, pp. 364-387.
- [6] T.H. Hsu, L.Z. Lin, "Using fuzzy set theoretic techniques to analyze travel risk: An empirical study", *Tourism Management*, 27, 2006, pp. 968-981.
- [7] K.L. Wang, C.C. Weng, and M.L. Chang, "A study of technical efficiency of travel agencies in Taiwan", *Asia Pacific Management Review*, 6(1), 2001, .73-90 [in Chinese].
- [8] C.Hales, and H. Shams, "Cautious incremental consumption: A neglected consumer risk reduction strategy", *European Journal of Marketing*, 25(7), 1991, pp. 7-21.
- [9] J.E. Bigné, M.I. Sánchez, and J. Sánchez, "Tourism image, evaluation variables and after purchase behavior: inter-relationship", *Tourism Management*, 26(6), 2001, pp. 607-616.
- [10] C.F. Chen, and D. Tsai, "How destination image and evaluative factors affect behavioral intentions?", *Tourism Management*, 28(4), 2007, pp. 1115-1122.
- [11] P.Fakeye, and J. Crompton, "Image Differences between Prospective, First-Time, and Repeat Visitors to the Lower Rio Grande Valley", *Journal of Travel Research*, 30(2), 1991, pp.10-16.
- [12] C.T. Lin, Y.L. Huang, "Mining tourist imagery to construct destination image position model", *Expert Systems with Applications*, 36, 2009, pp. 2513-2524.
- [13] J. Roodurmun, and T.D. Juwaheer, "Influence of trust on destination loyalty – an empirical analysis - the discussion of the research approach", *International Research Symposium in Service Management*, 2010, pp. 1-23.
- [14] V.W. Mitchell, and M. Greatorex, "Risk perception and reduction in the purchase of consumer services", *The Service Industries Journal*, 13(4), October, 1993, pp. 179-200.
- [15] Y. Reisinger, and F. Mavondo. "Travel Anxiety and Intention to Travel internationally: implication of Travel Risk perception", *Journal of Travel Research*, 43, 2005, pp. 212-245.
- [16] C. Ryan, "Linkages between holiday travel risk and insurance claims: evidence from New Zealand", *Tourism Management*, 17(8), 1996, pp. 593-601.
- [17] P.Simpson, J.A.Siguaw, "Perceived Travel Risks: The Traveler Perspective and Manage ability", *International Journal of Tourism Research*, 10(4), 2008, pp. 315-327.
- [18] A. Lepp, and H. Gibson, "Tourist Roles, Perceived Risk and International Tourism", *Annals of Tourism Research*, 30(3), 2003, pp. 606-624.
- [19] H.P.van Dalen, and K. Henkens, "Explaining low international labour mobility: the role of networks, personality, and perceived labour market opportunities", *Population, Space, Place*, 18, 2012, pp. 31-44.
- [20] T.A.Hallahan, R.W.Faff, and M.D.McKenzie, "An empirical investigation of personal financial risk tolerance", *Financial Services Review*, 13(5), 2004, pp. 57-78.
- [21] A.M. Williams, V.Baláz, "Tourism, risk tolerance and competences: Travel organization and tourism hazards", *Tourism Management*, 35, 2013, pp. 209-221.
- [22] P.Pearce, "Perceived Changes in Holiday Destinations", *Annals of Tourism Research*, 9, 1982, pp.145-164.
- [23] A. Yiannakis, and H.Gibson, "Roles Tourist Play", *Annals of Tourism Research*, 19, 1992, pp.287-303.

- [24] M. Kozak, J. C. Crofts, and R. Law, "The impact of the perception of risk on international travelers", *International Journal of Tourism Research*, 9(4), 2007, pp. 233–242.
- [25] C. H. C. Hsu, K. Wolfe, and S. K. Kang, "Image Assessment for a Destination with Limited Comparative Advantages", *Tourism Management*, 25, 2004, pp. 121–126.
- [26] A. R. Bauer, "Consumer Behavior as Risk Taking, Dynamic Marketing in the Changing World", Robert S. Hancock, Chicago: American Marketing Association, 1960, pp. 389–398.
- [27] A. Lo, and T. Lam, "Long-haul and short-haul outbound all-inclusive package tours", *Asia Pacific Journal of Tourism Research*, 9(2), 2004, pp. 161–176.
- [28] S. F. Sönmez and A. R. Graefe, "Influence of terrorism risk on foreign tourism decisions", *Annals of Tourism Research*, 25, 1998, pp. 112–144.
- [29] J. Wong, and C. Yeh, "Tourist hesitation in destination decision making", *Annals of Tourism Research*, 36(1), 2009, pp. 6–23.
- [30] S. Dolnicar, "Understanding barriers to leisure travel: tourist fears as a marketing basis", *Journal of Vacation Marketing*, 11(3), 2005, pp. 197–208.
- [31] A. Lo, C. Cheung, and R. Law, "Hong Kong Residents' Adoption of Risk Reduction Strategies in Leisure Travel", *Journal of Travel and Tourism Marketing*, 28(3), 2011, pp. 240–260.
- [32] Knight, F. H., *Risk, uncertainty and profit*, Boston: Houghton Mifflin, 1921.
- [33] O. Silva, H. Reis, and A. Correia, "The moderator effect of risk on travel decisionmaking", *International Journal of Tourism Policy*, 3(4), 2010, pp. 332–347.
- [34] S. Baloglu, and D. Brinberg, "Affective images of tourism destinations", *Journal of Travel Research*, 35(4), 1997, pp. 11–15.
- [35] J. L. Crompton, "An assessment of the image of Mexico as a vacation destination and the influence of geographical location upon that image", *Journal of Travel Research*, 17, 1979, pp. 18–23.
- [36] Gunn, C., *Vacationscape: Designing Tourists Regions*, 2nd edition, Van Nostrand Reinhold, New York, 1988.
- [37] A. Bonn *et al.*, "International versus Domestic visitors: An Examination of Destination Image Perceptions", *Journal of Travel Research*, 43, 2005.
- [38] L. A. Cai, "Cooperative branding for rural destinations", *Annals of Tourism Research*, 29, 2002, pp. 720–742.
- [39] A. Alhemoud, and E. G. Armstrong, "Image of tourism attractions in Kuwait", *Journal of Travel Research*, 34(4), 1996, pp. 76–80.
- [40] J. E. Bigné, M. I. Sánchez, and J. Sánchez, "Tourism image, evaluation variables, and after purchase behavior: inter-relationship", *Tourism Management*, 26, 2001, pp. 607–616.
- [41] I. Zahra, "Destination image and tourism: A case study of Bangladesh", *European Journal of Business and Management*, 4(6), 2012, pp. 18–27.
- [42] H. Oh, "Service quality, customer satisfaction, and customer value: a holistic perspective", *International Journal of Hospitality Management*, 18, 1999, pp. 67–82.
- [43] Y. Yoon, and M. Uysal, "An examination of the effects of motivation and satisfaction on destination loyalty: a structural model", *Tourism Management*, 26(1), 2005, pp. 45–56.
- [44] C. F. Chen, and P. C. Chen, "Another look at heritage tourism experience- Research Note", *Annals of Tourism Research*, 41, 2013, pp. 236–240.
- [45] H. J. Chen, P. J. Chen, F. Okumus, "The relationship between travel constraints and destination image: A case study of Brunei", *Tourism Management*, 35(2), 2013, pp. 198–208.
- [46] C. Echtner, and B. Ritchie, "The meaning and measurement of destination image", *Journal of Tourism Studies*, 14(1), 2003, pp. 37–48.
- [47] S. Elliot, N. Papadopoulos, and S. Kim, "An Integrated Model of Place Image: Exploring Tourism Destination Image and Product-Country Image Relationships", *Journal of Travel Research*, 50(5), 2011, pp. 520–534.

- [48] J. Hunt, "Image as a Factor in Tourism Development", *Journal of Travel Research*, 13(3), 1975, pp. 1–17.
- [49] S. Veasna, W.Y. Wu, C.H. Huang, "The impact of destination source credibility on destination satisfaction: The mediating effects of destination attachment and destination image", *Tourism Management*, 36, 2013, pp. 511–526.
- [50] L. Moutinho, "Consumer Behaviour in Tourism", *European Journal of Marketing*, 21(10), 1987, pp. 5–44.
- [51] M. Uysal, and L.A. Hagan, "Motivations of Pleasure Travel and Tourism. In M. Khan, M. Olsen and T. Car (Eds.)", VNR's *Encyclopedia of Hospitality and Tourism*, New York: Van Nostrand Reinhold, 1993, pp. 798–810.
- [52] P.A. Weaver, K.W. McCleary, L.R. Lepisto, and L.T. Damonte, "The Relationship of Destination Selection Attributes to Psychological, Behavioral and Demographic Variables", *Journal of Hospitality and Leisure Marketing*, 2(2), 1994, pp. 93–109.
- [53] M. Uysal, X. Li, and E. Turk, "Push-Pull Dynamics in Travel Decisions", In the *Handbook of Hospitality and Tourism Marketing*, edited by H. Oh and A. Pizam, Published by Elsevier, 2008. pp. 412–438.
- [54] J. L. Crompton, S. L. McKay, "Motives of visitors attending festival events", *Annals of Tourism Research*, 24(2), 1997, pp. 425–439.
- [55] Saunders, M., P. Lewis, and A. Thornhill, *Research methods for business students* (4th ed.), London: Prentice Hall, 2007.
- [56] R.M. Baron, and D.A. Kenny, "The moderator-mediator variable distinction in social psychological research: conceptual, strategic, and statistical considerations", *Journal of Personality and Social Psychology*, 55(6), 1986, pp. 1173–1182.
- [57] Hair, J., W. Black, B.J. Babin, and R.E. Anderson, *Multivariate data analysis* (7<sup>th</sup> ed.). New Jersey: Prentice Hall, 2010.
- [58] H. Ro, "Moderator and mediator effects in hospitality research", *International Journal of Hospitality Management*, 31(3), 2012, pp. 952–961.
- [59] Jöreskog, K. G., and D. Sörbom, *LISREL VI: Analysis of linear structural relationships by maximum likelihood and least square methods*, Mooresville, IN: Scientific Software, Inc., 1986.
- [60] Nunnally, J.C., and I.H. Bernstein, *Psychometric theory* (3rd ed.), New York: McGraw-Hill, 1994.
- [61] C. Fornell, D.F. Larcker, "Evaluating structural equation models with unobservable variables and measurement error", *Journal Mark Res*, 18(1), 1981; pp. 39–50.
- [62] C. Whan Park, D.J. MacInnis, J. Priester, A.B. Eisingerich, and D. Iacobucci, "Brand attachment and brand attitude strength: conceptual and empirical differentiation of two critical brand equity drivers", *Journal of Marketing*, 74(6), 2010, pp. 1–17.
- [63] A. Yuksel, F. Yuksel, and Y. Bilim, "Destination attachment: effects on customer satisfaction and cognitive, affective and conative loyalty", *Tourism Management*, 31(2), 2010, pp. 274–284.
- [64] G. Prayag, and C. Ryan, "Antecedents of tourists' loyalty to Mauritius: the role and influence of destination image, place attachment, involvement, and satisfaction", *Journal of Travel Research*, 10(5), 2011, pp. 51–65.

# Executive Incentives and Firm Defaults of Executive Stock Options

Jin-ray Lu

Department of Finance, National Dong Hwa University, Taiwan  
[jinray@mail.ndhu.edu.tw](mailto:jinray@mail.ndhu.edu.tw)

## Abstract

*The valuations of executive stock options (ESOs) depend not only on whether a stock price exceeds a strike price, but also on whether the firm value can sufficiently cover promised debts. If a firm's value is lower than the promised debts, the board of directors may not make full option payoffs to the executives. Taking into account this possibility of the option writer defaulting, the executives may have an incentive to change their efforts and management decisions, and the board of directors may also have an incentive to engage in strategic behavior aimed at motivating the executives. Therefore, ESO valuations should take into account both the firms' default risk and executives' incentives. Our results indicate that changing various option-specific parameters can affect the incentive strengths and default probabilities. The executives have an incentive to enhance contract value by increasing their effort or risk-taking. If firm values are lower, and promised debt payments and employee salary compensation are higher, a firm has a greater likelihood of defaulting on the contracts. The two parties can design an appropriate contract or implement their own control policies to affect the incentives and default probabilities.*

## 1. Introduction

Executive stock options (ESOs) are issued by a board of directors to executives for the purpose of motivating the executives to expend greater effort for the ultimate benefit of the shareholder's. With respect to a constant payment of salary, the ESOs can create potential payoffs for the executives if the ESOs are exercised. To increase the opportunity for profit under an ESO contract, executives have incentives to create shareholder value. Nowadays, in many countries, the ESO has come to be widely regarded as an effective tool in terms of incentive compensation plans (See, Quintero *et al.* 1997; Bryan *et al.* 2002; Lambert 1986; Coles, *et al.* 2006).

Under some conditions, however, the board of directors does not always make sufficient payoffs to the executives, even though the ESOs are exercisable upon maturity. As a result, the holders of ESOs bear a risk generated from the option writer's possibility of defaults. Specifically, if a firm's value does not cover its promised liabilities, the firm may default on the payment of ESO contracts due to payment priority orders. Considering this option writer's default possibility, the executives may have incentive to change their efforts and management decisions. On the other hand, the board of directors may adjust corporate salary policies and ESO designs for the purpose of motivating the executives. Thus, ESO valuations should take into account the default risk of the option writers and the incentive effects of the executives.

Specifically, given some circumstances, ESO holders may suffer losses as a result of the default risk they bear in cases where a firm's value is insufficient to pay its promised debts upon maturity. First, before making the option payoffs to the executives and paying the dividends to the shareholders, the firm's value shall be distributed to outside debt holders and to employees to satisfy promised liabilities and make salary compensation, respectively. Thus, ESO contract defaults depend on firm values, firm salary policy, and promised debts. During an economic depression, some firms have defaulted on their ESO grants. A second reason why ESOs may be defaulted upon involves a trading mechanism. An ESO contract, issued by the board of directors of a firm, is a derivative of OTC markets, and is not traded in an exchange market. Any contract traded on OTC markets may have a possibility of default. As a result, the pricing of ESOs with default risk must take into account the firm's default probability. Previous studies have not yet discussed the valuation of ESOs taking into account the probability of writer default.

This study analyzes ESOs under a consideration of the default risk generated by the option writer's potential for default. If a firm's value is not enough to

pay outside liabilities and make salary compensation, the holders of ESOs will receive only a portion of the full payoffs they are owed, even if the ESO contract is in a condition of in-the-money, in which case the boards of directors can be said to be in default on the ESOs they have issued. Under other conditions, the holders of ESOs can receive full payoffs of amounts, so long as the firm's value is high enough. Consequently, the valuations of ESO contracts are related to whether the firm defaults on making the promised payoffs under them.

A lot of the financial literature has discussed default effects on option contracts, specifically focusing on vulnerable options, in terms of their default mechanisms (see, for example, Merton 1974; Klein 1996; Johnson and Stulz 1987; Hull and White 1995; Jarrow and Turnbull 1995; Klein and Inglis 2001; Basak and Shapiro 2005; Uhrig-Homburg 2002; Moraux 2004; Klein and Yang 2010; Lu *et al.* 2013). For example, Johnson and Stulz (1987) developed a pricing mechanism for vulnerable options and discussed possible properties considering the probability of default. Furthermore, Klein (1996) took option writers' outside liabilities to be a default boundary under occurrences of financial distress. Considering a default boundary which includes the potential liability represented by the options and the other debts of option writers, Klein and Inglis (2001) valued European options subject to the risk of financial distress generated by the option writers. Thus, the holders of option contracts may bear default risk even though the contracts can stay in-the-money upon maturity.

Another major issue in the area of ESOs involves discussing the incentive effects on the executives (see, for example, Johnson and Tian 2000; Coles *et al.* 2006; Burns and Kedia 2006; 2008; Chen *et al.* 2006; Cheung and Corrado 2009; Brockman *et al.* 2010; Dong *et al.* 2010; Tang 2012; Armstrong and Vashishtha 2012; Álvarez-Díez *et al.* 2013; Cronqvist and Fahlenbrach 2013). For example, comparing the incentive effects of numerous ESO plans, Johnson and Tian (2000) suggested changing specifications of option parameters could bring about significant changes in executive incentives. Chen *et al.* (2006) stressed the relation between option-based executive compensation and risk-taking incentives, and found that stock with an option-based value can induce risk-taking. Dong *et al.* (2010) documented that debt issuing decisions were correlated to stock return volatility due to executives' ESO holdings. Specifically, they found support for the contention that the executives took on too much risk and undertook

sub-optimal capital structure decisions as a result of the fact that the executives' wealth is sensitive to stock volatility. Tang (2012) constructed a multi-period framework to analyze the incentive effects of ESOs, and suggested that restricted stock generated greater incentives to change stock prices. Armstrong and Vashishtha (2012) documented that option *vega* gave executives incentive to increase their total risk by increasing systematic risk, but not idiosyncratic risk.

The current article differs from previous studies and contributes to the financial literature in the following ways. As the holders of ESOs face default risk generated from the insurers' behavior, the valuations of ESOs are thus related to the firms' default risks. Specifically, under the default risk we explore the executives' incentives to alter their risk-taking and efforts, as well as the strategic reflections of the boards of directors. That is, this study analyzes *whether* and *how* the executive incentives change, and *whether and how* the firm's reflections change with respect to executive incentives, considering issuers' defaults. Then, this study is also the first to explore the default possibility of ESO issuers and to analyze *how* the executives change their decisions in response to issuers' defaults. In particular, this study analyzes the effects of firms increasing outside liabilities and salary payments on the default probabilities, and discusses *how* the executives change their efforts and management decisions related to risk-taking and dividend policy to reflect the firm's behavior.

In short, this study attempts to value ESO contracts with issuer default risk, to explore executive's incentives, board of director's defaults, and the two parties' strategic behaviors. First, this study derives a closed-form solution for the ESO contracts under default risks originated in insufficient firm values to pay outside liabilities and make salary payments. Second, this study analyzes executive incentives to increase stock price and return volatility, and discusses boards of directors' salary policy, debt policy, and contract design in response to the executive incentives. Third, the study also derives a default probability of ESOs and predicts the boards of directors' default behaviors in terms of salary policy and debt policy. In addition, we also discuss *how* the executives implement their strategies in terms of dividend policy, risk management policy, and their overall efforts in response to the firm's default behaviors in relation to the ESOs. Using a martingale methodology and an option analysis of games, the study can solve closed-form results, and can explore incentive effects, default effects, and strategic behaviors, respectively.

The study is organized in four main sections. The following section develops an option model for deriving option premiums, incentives, and default probabilities. The third section implements numerical examples to characterize the ESO premiums, incentives, and default probabilities in terms of specified factors. The study also discusses the economic implications for these results within a framework of option analysis of games. The final section summarizes the main findings.

## 2. Valuation Model, Incentives, and Default Probability

This section develops an option pricing model for valuing ESOs with default risk. Using a martingale approach, we derive a closed-form solution for ESOs. Executive incentives and firm defaults in the context of the ESOs are also analyzed. In addition, we give a probability analysis based on option writers' defaults.

### 2.1 ESOs with default risk

To solve a closed-form result for ESOs, this article sets out numerous underlying assumptions and constructs a preliminary option pricing model. Our underlying assumptions are consistent with the work of Black and Scholes (1973), Klein (1996), and Klein and Inglis (2001). A representative firm has movements of firm value ( $V$ ) and stock price ( $S$ ) following a geometric Brownian motion (GBM) process framed in a complete probability space  $(\Omega, \mathfrak{F}, P)$  with filtration  $\{\mathfrak{F}_t\}$ , as follows:

$$\frac{dV}{V} = rdt + \theta dZ^Q(t) \quad (1)$$

and

$$\frac{dS}{S} = (r - q)dt + \sigma dW^Q(t) \quad (2)$$

where  $Z$  and  $W$  denote *Wiener processes* in a risk-neutral probability  $Q$ -measure.  $r$  represents a risk-free rate of interest.  $\theta$  and  $\sigma$  are the instantaneous volatility rates of the firm value and stock price, respectively.  $q$  is a continuous dividend rate that the firm pays to the shareholders.

For simplicity's sake and without the loss of generality, the ESO is in the form of plain vanilla European call option, and is free of attached restrictions on it, so as to allow us to focus on the valuation, considering the default risk originated in the option writer's behavior. For rewarding the executives, the board of directors issues the executive stock option contracts on the firm's stock price ( $S$ ) with a strike

price ( $K$ ), whereby the executives have an incentive to enhance ESOs' values by altering their efforts in terms of firm management. On maturity, the ESO holder can receive *some* payoffs, depending on whether the stock price is over the strike price. That is, as the stock price exceeds the pre-specified strike price, the executives receive a payoff of  $S - K$ . However, whether or not the executives obtain the payoffs is dependent on the firm's value exceeding a default barrier. Specifically, the executives cannot receive full payoffs upon maturity ( $T$ ) if a firm's asset values are not sufficient to make payments to outside bondholders and employees. More specifically, before paying out the option payoffs, the firm should pay off outside debts to the bondholders and salaries to its employees. For this reason, the valuations of ESOs involve a condition of whether or not the option writer defaults. In total, the ESO value at time  $t$  is expressed as follows:

$$C_t = e^{-r(T-t)} E \left\{ \begin{array}{ll} S_T - K, & \text{if } S_T \geq K, V_T \geq B + mV_T \\ (S_T - K) \left[ \frac{(1-\alpha)V_T}{B + mV_T} \right], & \text{if } S_T \geq K, V_T < B + mV_T \\ 0, & \text{otherwise} \end{array} \right\} \quad (3)$$

where  $B$  represents a fixed default boundary, which can be regarded as the firm debts (See, Klein 1996).  $\alpha$  is a rate of dead-weight costs generated from the occurrence of financial defaults.  $mV$  denotes a salary payment that it is expressed as a fixed portion of the firm value with a fixed salary policy  $m$ . A higher value of  $m$  means that a firm pays more compensation to its employees. Under these settings, this study can explore how the dividend policy ( $q$ ), debt policy ( $B$ ), and salary policy ( $m$ ) affect the ESO valuations, as well as both parties' incentive effects and default effects. Specifically, the outside debts and salary payments have higher priority than dividend payouts or option payoffs.

The valuation of ESOs mainly depends on which of two situations the case falls under, in terms of whether or not the firm defaults, as shown in equation (3). The first line of this equation states a standard form of the payoffs for the call options on the stock prices, but the firm's board of directors definitely makes the payoffs in of the case where the firm value covers the total of the promised debt payments and employees' salaries. In the other situation, that is, where the firm's value is too low to make the promised debt payouts and pay the salaries, the executive receives *part* of the full option payoff, as indicated in the second line of the equation. As the option writer defaults, the ESO holder receives a part of the available amount of the net firm value (i.e.,  $(1-\alpha)V$ ) with respect to the full terminal payoffs. In particular, the dividend payouts and option payoffs

are not taken into account in the total promised necessary payments (i.e.,  $B+mV$ ) before the firm pays debts and makes salary payments, so they do not appear in the denominator of the portion in the second line of the equation.

The ESO price ( $C_t$ ) at time  $t$  can be derived by discounting the expected closing price ( $C_T$ ) using a risk neutral probability and a risk-free rate in a martingale approach. The closed-form solution for the value of the ESOs is given as follows:

$$(4) \quad C_t = S_t e^{-q(T-t)} N(b_1, b_2; \rho) - K e^{-r(T-t)} N(a_1, a_2; \rho) + \frac{(1-\alpha)V_t}{B+mV_t} (S_t e^{(r-q-y+\rho\sigma\theta)(T-t)} N(c_1, c_2; -\rho) - K e^{-y(T-t)} N(d_1, d_2; -\rho))$$

where,

$$a_1 = \frac{\ln(S_t/K) + (r-q-\sigma^2/2)(T-t)}{\sigma\sqrt{T-t}}$$

$$a_2 = \frac{\ln((1-m)V_t/B) + (r-\theta^2/2)(T-t)}{\theta\sqrt{T-t}}$$

$$b_1 = \frac{\ln(S_t/K) + (r-q+\sigma^2/2)(T-t)}{\sigma\sqrt{T-t}}$$

$$b_2 = \frac{\ln((1-m)V_t/B) + (r-\theta^2/2 + \theta\rho\sigma)(T-t)}{\theta\sqrt{T-t}}$$

$$c_1 = \frac{\ln(S_t/K) + (r-q+\sigma^2/2 + \rho\sigma\theta)(T-t)}{\sigma\sqrt{T-t}}$$

$$c_2 = -\frac{\ln((1-m)V_t/B) + (r+\theta^2/2 + \rho\sigma\theta)(T-t)}{\theta\sqrt{T-t}}$$

$$d_1 = \frac{\ln(S_t/K) + (r-q-\sigma^2/2 + \rho\sigma\theta)(T-t)}{\sigma\sqrt{T-t}}$$

$$d_2 = -\frac{\ln((1-m)V_t/B) + (r+\theta^2/2)(T-t)}{\theta\sqrt{T-t}}$$

$$y = r - \frac{B}{B+mV} \left( r - \frac{m\theta^2 V}{B+mV} \right)$$

$$\eta = \frac{\theta B}{B+mV}$$

where  $N(x_1, x_2; \rho)$  denotes the cumulative density function of a standard bivariate normal distribution. The ESO solution is similar to the vulnerable option price developed by Klien (1996), but our model considers salary policy and applies to the area of executive stock options with default risks. The Appendix contains the derivation of this formula.

The closed-form solution for ESOs with default risks becomes more complicated than closed-form solution for ESOs without default risks. First, the payoff structure of the option can be separated into two standard types, represented by holding a plain vanilla call option on the stock price with a strike price of  $K$ ,

and by longing another call option given some possibilities. It should be noted, however, that the executives receive a part of the full payoffs of the second option. Second, there is one point that must be mentioned with respect to the normal distributions; the univariate normal distribution is used in the plain vanilla option contract, but the bivariate normal distribution is used for the ESO contract since the option value depends on two processes: stock prices and firm values. Finally, the default risk, which is originated in the condition where the firm value is less the total of the promised outside debts and employees salaries, can directly change the values of ESOs through numerous factors, such as the volatility rate ( $\theta$ ) of firm value, salary policy ( $m$ ), debt boundary ( $B$ ), and so on.

## 2.2 Incentive effects for executives

After the issuing of an ESO contract, the executives have motives to affect the underlying stock prices, return volatility, and dividend policy in order to increase the value of the ESO contracts. That is, an increase in the stock price, an increase on the return volatility, or a decrease in the dividend payout, may increase potential payoffs upon maturity, so the executives have an incentive to expend more effort in their business management and decision planning. The study therefore explores the executive incentives in terms of the strategic behavior of the two parties.

To analyze the incentives of the executives, the partial derivatives of the contract premium to the underlying stock price (*delta*), the return volatility (*vega*) of the stock price, and the dividend rate (*psi*) are used to measure the level of executive incentive to change stock price, risks and dividend policy. High values for the Greeks indicate that the executives have stronger incentives to affect terminal payoffs by changing their efforts on risk management or business operations. The formulas of these Greeks for the ESOs are listed as follows:

$$\Delta \equiv \frac{\partial C_t}{\partial S_t}$$



$$\begin{aligned}
&= e^{-q(T-t)}N(b_1, b_2; \rho) + S_t e^{-q(T-t)}n(b_1)N\left(\frac{b_2 - b_1\rho}{\sqrt{1-\rho^2}}\right)\frac{1}{\sigma S_t\sqrt{T-t}} \\
&\quad - Ke^{-r(T-t)}n(a_1)N\left(\frac{a_2 - a_1\rho}{\sqrt{1-\rho^2}}\right)\frac{1}{\sigma S_t\sqrt{T-t}} \\
&\quad + \frac{(1-\alpha)V_t}{B+mV_t}e^{(r-q-y+\rho\sigma\theta)(T-t)}[N(c_1, c_2; -\rho) \\
&\quad + S_t n(c_1)N\left(\frac{c_2 + c_1\rho}{\sqrt{1-\rho^2}}\right)\frac{1}{\sigma S_t\sqrt{T-t}}] \\
&\quad - \frac{(1-\alpha)V_t K}{B+mV_t}e^{-y(T-t)}n(d_1)N\left(\frac{d_2 + d_1\rho}{\sqrt{1-\rho^2}}\right)\frac{1}{\sigma S_t\sqrt{T-t}}
\end{aligned} \tag{5}$$

$$\begin{aligned}
Vega &\equiv \frac{\partial C_t}{\partial \sigma} \\
&= S_t e^{-q(T-t)}n(b_1)N\left(\frac{b_2 - b_1\rho}{\sqrt{1-\rho^2}}\right)\left(\sqrt{T-t} - \frac{b_1}{\sigma}\right) \\
&\quad + S_t e^{-q(T-t)}n(b_2)N\left(\frac{b_1 - b_2\rho}{\sqrt{1-\rho^2}}\right)(\rho\sqrt{T-t}) \\
&\quad + Ke^{-r(T-t)}n(a_1)N\left(\frac{a_2 - a_1\rho}{\sqrt{1-\rho^2}}\right)\left(\frac{b_1}{\sigma}\right) \\
&\quad + \frac{(1-\alpha)V_t K}{B+mV_t}e^{-y(T-t)}n(d_1)N\left(\frac{d_2 + d_1\rho}{\sqrt{1-\rho^2}}\right)\left(\frac{b_1}{\sigma}\right) \\
&\quad + \frac{(1-\alpha)S_t V_t}{B+mV_t}e^{(r-q-y+\rho\sigma\theta)(T-t)}[N(c_1, c_2; -\rho)\rho\eta(T-t) \\
&\quad + n(c_1)N\left(\frac{c_2 + c_1\rho}{\sqrt{1-\rho^2}}\right)\left(\sqrt{T-t} - \frac{b_1}{\sigma}\right) \\
&\quad - n(c_2)N\left(\frac{c_1 + c_2\rho}{\sqrt{1-\rho^2}}\right)\rho\sqrt{T-t}]
\end{aligned} \tag{6}$$

$$\begin{aligned}
Psi &\equiv \frac{-\partial C_t}{\partial q} \\
&= S_t e^{-q(T-t)}n(b_1)N\left(\frac{b_2 - b_1\rho}{\sqrt{1-\rho^2}}\right)\frac{\sqrt{T-t}}{\sigma} \\
&\quad + (T-t)S_t e^{-q(T-t)}N(b_1, b_2; \rho) \\
&\quad - Ke^{-r(T-t)}n(a_1)N\left(\frac{a_2 - a_1\rho}{\sqrt{1-\rho^2}}\right)\frac{\sqrt{T-t}}{\sigma} \\
&\quad + \frac{(1-\alpha)S_t V_t}{B+mV_t}e^{(r-q-y+\rho\sigma\theta)(T-t)} * \\
&\quad [n(c_1)N\left(\frac{c_2 + c_1\rho}{\sqrt{1-\rho^2}}\right)\frac{\sqrt{T-t}}{\sigma} + (T-t)N(c_1, c_2; -\rho)] \\
&\quad - \frac{(1-\alpha)V_t K}{B+mV_t}e^{-y(T-t)}n(d_1)N\left(\frac{d_2 + d_1\rho}{\sqrt{1-\rho^2}}\right)\frac{\sqrt{T-t}}{\sigma}
\end{aligned} \tag{7}$$

where  $psi$  is defined as a negative partial derivative with respect to the dividend yield for expressing an incentive to reduce dividend payout for the executives.  $n(\bullet)$  denotes a probability density function of normal distribution.

Comparing them with the results of ESOs without default risks (i.e., a vanilla call option), these values of the Greek letters for ESOs with default risks display complicated forms. As shown in equations (5)-(7), it is difficult to find specific trends for these Greeks in terms of determinants. Thus, for the purpose of clearly recognizing the essential characteristics of contract Greeks or executive incentives, it is necessary to implement numerical analyses. Specifically, the study also analyzes strategic inter-dependences of the incentive effects, whereby we examine how the incentives of the executives change in response to the boards of directors' strategies.

### 2.3 Default Probability and Strategic Behaviors

If the firm value is insufficient to pay the promised outside liabilities and make salary payments, the executives may not receive a full terminal payoff, even though the ESOs become exercisable upon maturity. In the other condition, if the firm value exceeds the total value of the default barrier and the salary payments, the ESO holders receive full terminal payoffs. Consequently, the probability of whether or not the firm value is sufficient to satisfy the promised payments is critical for the ESOs with default risks. We further derive a closed-form result of default probability ( $P_{II}$ ) and full-payable probability ( $P_I$ ) for the ESO contracts, to analyze the possibilities of the above-mentioned situations, as follows:

$$P_I = P(S_T \geq K, V_T \geq B + mV) = N(a_1, a_2; \rho) \tag{8}$$

$$P_{II} = P(S_T \geq K, V_T < B + mV) = N(a_1, -a_2; -\rho) \tag{9}$$

$$P_{III} = 1 - N(a_1, a_2; \rho) - N(a_1, -a_2; -\rho) \tag{10}$$

where  $P_{III}$  represents a probability of other cases; for example, where the option is not exercised (in a situation of  $S_T < K$ ).

These probabilities are expressed in the form of cumulative function of bivariate normal distributions and are conditional on whether or not the stock price and firm value exceed the strike price and the total of the default boundary and salary payments, respectively. In particular, the dividend policy ( $q$ ), salary policy ( $m$ ), debt policy ( $B$ ), time to maturity ( $T-t$ ), return volatility ( $\sigma$ ) of stock prices, return volatility ( $\theta$ ) of firm values, and dead-weight cost ( $\alpha$ )

) can directly determine the non-exercisable probability ( $P_{III}$ ), full-payable probability ( $P_I$ ), and default probability ( $P_{II}$ ).

Next, the default effects of boards of directors are measured using the partial derivative ( $pi$ ) of the default probability with respect to the salary policy. That is, the  $pi$  refers to a possibility of the firm defaulting on the ESOs as the firm changes its salary policy. An increase in the salary payout rate ( $m$ ) can increase the probability of a firm defaulting. This study uses  $pi$  as a measure of default incentives in terms of salary policy ( $m$ ). It is derived as follows:

$$\begin{aligned}
 P_i &= \frac{\partial P_{II}}{\partial m} \\
 &= \frac{n(-a_2)}{\theta(1-m)\sqrt{T-t}} N\left(\frac{a_1 - a_2\rho}{\sqrt{1-\rho^2}}\right)
 \end{aligned}
 \tag{11}$$

Finally, the study further discusses the strategic behavior between the board of directors and executives in the game theory analysis of options. Taking into account the default behavior of the board of directors, the executives may adjust those factors which are within their control in order to affect the firm's likelihood of default. For example, to reduce the default motive (i.e.,  $pi$ ) of the board of directors, the executives may increase their level of risk-taking (i.e., increase  $\sigma$ ) when making decisions about corporate operations. In the following section, we examine *whether* and *how* the default motive of the board of directors changes in response to the strategic behavior of the executives.

### 3. Numerical Calibration

Through a numerical analysis, the study explores the premium characteristics, Greeks, incentive effects, and default probabilities of ESOs.

#### 3.1 Premium characteristics

First, we examine the premium characteristics in terms of numerous factors, such as the stock price, return volatility, debt boundary, and so on. Table 1 lists the premium changes for these factors, given certain specifications of parameters. The initial stock price ( $S$ ) is assumed to be \$120. The strike price ( $K$ ) of ESO is assumed to be \$100. The risk free rate ( $r$ ) and dividend payout yield ( $q$ ) have values of 3% and 2%, respectively. The time-to maturity is specified as 1 year. Initial firm value ( $V$ ) is given as \$500. Return volatilities ( $\sigma$  and  $\theta$ ) of the stock price and firm

value are 20% and 10%, respectively. Salary policy is given as  $m = 10\%$ . The coefficient of correlation between stock price and firm value is assumed to be  $\rho = 0.5$ . The debt boundary ( $B$ ) is given as \$450. The dead-weight cost is given as  $\alpha = 10\%$ .

The premium characteristics of ESOs with default risk are similar to those of plain vanilla call options, but the former involve more factors originated in the option writers' defaults. First, as shown in Panel A of Table 1, the contract premium ( $C$ ) is positively correlated with stock price and time-to-maturity, indicating that a higher stock price increases the potential for payoffs upon maturity. Figure 1 also shows a positive relationship between the contract premiums and stock price. Second, the ESO premium gradually increases with the return volatility ( $\sigma$ ) of the stock price. Figure 1 graphically displays the numerical results for the contract premium with respect to the return volatility. Third, a high salary rate ( $m$ ) and higher payments ( $B$ ) of outside liabilities depreciate the contract premiums because the firm is obliged to pay the promised debts and salary compensation first, since these have higher priority. Fourth, in accordance with our theoretical expectation, the dividend payout rate ( $q$ ) has a negative impact on the contract premium. Thus, the premium of an ESO contract with default risk displays a standard characteristic of vanilla call options; however, the premium is also determined by salary policy and debt policy, which involve the default risk.

#### 3.2 Contract Greeks and executive incentives

Next, we numerically examine the executive's incentives, which are measured by the Greeks. Although the Greeks of ESO contracts have complicated forms, as shown in equations (5)-(7), they displays a consistent trend when presented in graphic form. Figure 2 shows how the option's Greeks (*delta*, *vega*, and *psi*) change with the stock price and time to maturity. The ESO *delta* shows a similar trend to the *delta* of the plain vanilla call option. First, as the stock price is over the strike price (i.e.,  $K = \$100$ ), the *delta* approaches a maximum. Second, the option *delta* changes dramatically near the strike price. Next, the *delta* approaches zero if the stock price is less than the strike price. Then, the *delta* of a short-life contract changes more sensitively with respect to the underlying stock price than that of a long-life contract does. Finally, positive values of the option *delta* indicate that the ESO holder has an incentive to increase the stock price to increase contract value. That is, The ESO contract provides an incentive mechanism for

executives to undertake greater effort in business management.

Turning to the ESO *vega*, as shown in Panel B of Figure 2, we further examine the *vega* to analyze the executive incentive to take risks. Although the *vega* may appear as a negative value, in most ranges of stock price the option *vega* is positive. Specifically, the option *vega* displays a peak as the stock price locates near the strike price, at which point the ESO holder has the strongest incentive to enhance contract value by taking more risks in business operations. In addition, in contrast to the theoretical results for standard call options, the ESO *vega* presents negative values as the stock price is high enough. That is, the executive has no incentive to create contract value by taking more risks because the board of directors may default as the stock price tends to be higher. Besides, the long-life ESO contracts have larger *veg*as than short-life ESO contracts do, because the impacts of change return volatilities are greater on the contract values of the long-life contracts. Based on this analysis, in contrast to the *veg*as of ESO contracts without default risk, the *veg*as of ESO contracts with default risk exhibit specific properties because of their default risks generated from the behavior of the boards of directors. Thus, given these specific properties of contract *veg*as, the holders of ESO contracts have various incentives to implement their decisions in terms of risk management.

The study further discusses how the executives make their dividend policy in terms of an analysis of incentive effects. In this article, a higher value for contract *psi* indicates that the executives have stronger incentives to reduce dividend payout rates. As shown in Panel C of Figure 2, the ESO holders have weak incentives to alter dividend policy as the stock prices are lower, and have strong incentives to do so as the stock prices are higher. Specifically, the executives have strong incentives to reduce dividend payouts in order to avoid a decrease in the ESO values as the contract stays in a condition of in-the-money. In addition, the sensitivities of option *psi* are larger for a long-life ESO contract, in the sense that a long-life contract's incentive effect to reduce dividend payouts is stronger.

### 3.3 Executive's incentives in a game analysis of options

The boards of directors issue ESOs to the executives for the purpose of motivating the executives to create shareholder value, so boards of directors can adjust the contract designs of ESOs, change capital structures (i.e., debt policy), or salary policy, to affect

the executive incentives. By way of a game theory analysis of options developed by Ziegler (2004), this section numerically analyzes how the incentive effects change with specific strategies on the part of a board of directors. For exploring how the executive incentives change, the study adjusts the strike prices and times to maturities in the contract design, as well as the salary policy.

We first observe the impacts of strike price on the executive incentives, as shown in Panel A of Table 2. The executive incentives to increase the stock price (*delta*) is a negative function of the strike price, indicating that an ESO contract with a low strike price provides a strong incentive to create contract value or shareholder value by increasing stock price. Next, if the strike price increases, the executive incentive to take more risks (*vega*) also increases. That is, the executives have stronger motivation to undertake risky strategies in their business decisions, for the purpose of increasing the contract value if the ESO contract has a high strike price. Thus, based on this analysis, a board of directors can increase the executive incentive to increase stock prices and decrease the executive incentive to increase return volatility in order to create shareholder value by designing an ESO contract with a low strike price. Specifically, an ESO contract with a low strike price also increases the executives' incentive to reduce dividend payouts in order to enhance contract value.

Turning to the maturity date, we find that a short-life ESO contract is preferred by the boards of directors for increasing executives' incentives in terms of their working effort, and for reducing executives' incentives in terms of risk-taking. However, a short-life ESO contract may eliminate the executives' incentives with respect to the dividend payouts. As shown in Panel B, the price sensitivity (i.e., *delta*, effort incentive of executives) is negatively correlated with the time to maturity of the ESO, while the risk sensitivity (i.e., *vega*, risk's incentive effect) and dividend sensitivity (i.e., *psi*, dividend policy's incentive effect) are positively correlated to the time to maturity of the ESO contract. That is, the firm can design a short-life ESO contract that will encourage executives to undertake more effort and adopt low-risk plans in their operational decisions.

We next examine the salary policy of the board of directors. If a firm takes a "loose" approach to salary policy (i.e., a larger value of *m*), the firm increases its promised payments before paying out the potential payoffs to the ESO holders. That is, the default boundary increases, and the ESO contract has a higher possibility of default. Panel C of Table 2 shows how

three executive incentives vary with the salary payouts ( $m$ ). As we gradually adjust the level of the salary payouts from 0% to 40%, the executives' incentive effect to increase stock price ( $\Delta$ ) decreases, and the incentive to reduce dividend payouts ( $psi$ ) also decreases, yet the risk incentive ( $vega$ ) exhibits a mixed result. These results indicate that the executives have little motivation to enhance contract value when a firm takes a "loose" approach to salary policy because there is a higher possibility that the ESO contracts will be defaulted upon.

In short, by designing ESO contracts with various strike prices and times to maturity and implementing various salary policies, a firm can change the executives' incentives to alter their efforts, risk management, and dividend policies. The incentive effects of ESO contracts for executives vary with the strategic behavior of the board of directors. Specifically, subject to the default risk, the executives' incentive to create contract value by altering stock prices, return volatility, and dividend payout yields involve the contract design and firm strategies.

### 3.4 Probability analysis

It is important for the executives to recognize the default risk of ESO contracts, whereby the potential payoffs upon maturity will not be fully paid if the firm value is insufficient to pay the total of promised outside liabilities and salary compensation. We analyze a default probability ( $p_{II}$ ), a full-payable probability ( $p_I$ ), and a non-exercisable probability ( $p_{III}$ ) for the executives under a consideration of ESO contracts with default risks originated in the option writers' default probability.

We first examine the cumulative distributions of the three probabilities based on numerous factors, as shown in Figure 3. First, both the full-payable probability and default probability increase with the stock price ( $S$ ), indicating that ESOs tend to be exercisable; however, the default risk also tends to increase if the stock price increases. Second, the default probability ( $p_{II}$ ) is positively related with the return volatility ( $\theta$ ) of the firm value, but the full-payable probability ( $p_I$ ) is not. Other conditions being equal, a higher return volatility of firm value increases the possibility of the firm value being less than the total of the promised payments. Third, as the debt payments ( $B$ ) and salary compensation ( $m$ ) gradually increase, the default probability tends to increase and the full-payable probability tends to decrease. Finally, the return volatilities of the firm value, debt payments,

and salary compensation do not change the non-exercisable probability, because the factors involve whether the firm defaults or not, and do not involve whether or not the ESOs are exercised. Thus, the cumulative distributions of the three probabilities give us some insights regarding whether and how the default risk changes based on stock prices, return volatilities, capital structures, and salary policies.

Next, the current study focuses on the default probability to explore the properties of the default risks of ESO contracts. Under varying specifications of numerous factors, Table 3 shows the probability properties of the default risk. First, based on the initial stock prices, the default probability displays a growth trend in Panel A of Table 3. That is, the ESO contract has a higher default possibility if the stock price increases. Second, the return volatility ( $\sigma$ ) of the stock price can cause a negative effect on the default probability; conversely, the return volatility ( $\theta$ ) of the firm value has a positive impact on the probability. Third, the default probability increases with the debt payments ( $B$ ) and salary compensation ( $m$ ) because latter two enlarge the default boundary. Fourth, the dividend rate ( $q$ ) reduces the default probability because it devalues the stock price and then reduces the possibility of the ESOs being exercised. Thus, the default risk increases as some policies (i.e., salary, capital structure, or dividend policy) or some determinants (i.e., stock price or return volatility) change.

Figure 4 shows how the default probabilities vary with the stock price, return volatility of firm value, and salary policy. As mentioned in the discussions above, these factors can directly increase the default risks of ESO contracts. Specifically, if the firm adopts a "loose" salary policy, it means that the firm has a high probability of defaulting.

### 3.5 Contract Greeks and default effects

For analyzing the board of directors' default behavior, the study uses contract Greeks to measure the extent of default effects. The  $pi$  is defined as the partial derivative of the default probability with respect to the salary payouts, which means it is sensitive to the default risk regarding the firm's behavior.

The board of directors has a stronger default incentive as the ESO contract stays in a deep in-the-money condition. As shown in Figure 5, as the stock price gradually increases, which means the contract tends to stay deep in-the-money, the  $pi$  value tends to be larger. The executives enjoy more payoffs if the stock price continuously increases; thus, the board of

directors may default on making full payoffs to the executives, rather than paying out a part of the full payoffs. In addition, a positive  $pi$  value indicates that the firm can increase salary payouts to increase the default possibility. Finally, a short-life ESO contract is more sensitive in terms of the default effects.

### 3.6 Firm's defaults in a game analysis of options

Given default risks of ESO contracts originating in the board of directors' behavior, the executives can assume an appropriate ESO contract coordinated with the issuers, and can alter their efforts, risk-takings, or dividend policy to affect the firm's default behaviors. The current study thus analyzes how the firm's default behavior changes in response to the executives' strategies. In particular, we adjust the strike prices and times to maturity in the contract designs, and change the stock price, return volatility, and dividend policy.

The default behavior of a board of directors is directly correlated with the contract design and the executives' efforts. First, as shown in Table 4, an ESO contract with a high strike price ( $K$ ) will decrease the default effects of the firm. One possible explanation for this is that ESOs with a high strike price have a low exercisable probability (i.e., including full-payable probability and default probability). The firms thus have weak default incentives to change their salary policy for the purpose of raising the default possibility. Second, as shown in Panel B of Table 4, the default effect is stronger for a short-life ESO contract, and the firms have a low incentive to default on a long-life ESO contract. These results imply that the executives prefer a long-life contract. Third, if the executives undertake little effort to increase stock price, to decrease return volatility, and to decrease dividend payouts in order to create more contract value, the firm has a weak motive to default. That is, given these conditions, the ESO contract has a lower exercisable possibility, and the firm thus has lower incentive to change its salary policy for the purpose of affecting the default probability.

Consequently, executives assuming ESO contracts with various strike prices and times to maturity, as well as their undertaking efforts at various levels, can affect the firm's default behavior. Specifically, to mitigate the default effects of the board of directors, the executives can adopt the following strategies: increasing strike price and time to maturity in the ESO contract design, increasing stock price, decreasing the return volatility of the stock price, and decreasing dividend payouts. However, the default effects of the board of directors

and the incentives effects of the executives can affect each other by altering both parties' strategies.

## 4. Conclusion

This article explores and values ESO contracts with default risks, focusing on the analysis of valuations, executive incentives, firm defaults, and the two parties' strategic behaviors. An ESO holder may receive some payoff depending on whether the stock price is over the strike price and whether the firm value exceeds a default barrier. We derive closed-form solutions for ESO contracts, and, in addition, we analyze whether executives have incentive to create contract value by altering the stock price, risk-taking, and dividend policy, and whether or not the firm defaults in terms of their salary policy. The strategic inter-dependences of two parties are also discussed by way of a game theory analysis of option.

This study of incentives and defaults under ESO contracts suggests a number of interesting findings and implications. First, the formula of an ESO contract with default risks is more complicated than that of an ESO contract without default risks, and the formula involves both whether the stock price is over the strike price and whether the firm's value is sufficient to pay outside debt-holders and its employees. Second, under some conditions, executives have incentive to create contract value by increasing their efforts or risk-taking in making management decisions or altering dividend policy. However, the executives may prefer low-risk plans as the stock price becomes high enough. Third, if the firm value is lower, and promised debt payments and salary compensation are higher, the firm may tend to default on the ESO contracts. Finally, the two parties can design an appropriate contract (in terms of strike price and time to maturity) or implement their own control policies (i.e. dividend policy, capital structure, or salary policy) to affect each other's incentives and default behavior. Thus, this article contributes to the consideration of default risk originating in option writers' defaults, and highlights the specific issues of executive incentives, firm defaults, and strategic inter-dependences in a game theory analysis of options.

## References

- [1] Álvarez-Díez, S., Baixauli-Soler, J. S., and Belda-Ruiz, M. (2013) Are we using the wrong letters? An analysis of executive stock option Greeks, *Central European Journal of Operations Research*, forthcoming.

- [2] Armstrong, C. S. and Vashishtha, R., (2012) Executive stock options, differential risk-taking incentives, and firm value, *Journal of Financial Economics* 104, 70-88.
- [3] Basak, S. and Shapiro, A., (2005) A model of credit risk, optimal policies, and asset prices, *Journal of Business* 78, 1215-1266.
- [4] Black, F. and Scholes, M., (1973) The valuation of options and corporate liabilities, *Journal of Political Economy* 8, 637-659.
- [5] Brockman, P., Martin, X. and Unlu, E., (2010) Executive compensation and the maturity structure of corporate debt, *Journal of Finance* 65, 1123-1161.
- [6] Bryan, S., Hwang, L. and Lilien, S., (2002) CEO stock-based compensation: An empirical analysis of incentive-intensity, relative mix and economic determinants, *Journal of Business* 73, 661-693.
- [7] Burns, N. and Kedia, S., (2006) The impact of performance-based compensation on misreporting, *Journal of Financial Economics* 79, 35-67.
- [8] Burns, N. and Kedia, S., (2008) Executive options exercises and financial misreporting, *Journal of Banking & Finance* 32, 845-857.
- [9] Chen, C., Steiner, T., and Whyte, A., (2006) Does stock option-based executive compensation induce risk-taking? An analysis of the banking industry, *Journal of Banking and Finance* 30, 915-945.
- [10] Cheung, J. and Corrado, C. (2009) Valuation and incentive effects of hurdle rate executive stock options, *Review of Quantitative Finance and Accounting* 32, 269-285.
- [11] Cox, J. C. and Ross, S. A., (1976) The valuation of options for alternative stochastic processes, *Journal of Financial Economics* 3, 145-166.
- [12] Cronqvist, H. and Fahlenbrach, R., (2013) CEO contract design: How do strong principals do it? *Journal of Financial Economics*, forthcoming.
- [13] Dong, Z., Wang, C.B and Xie, F., (2010) Do executive stock options induce excessive risk taking? *Journal of Banking & Finance* 34, 2518-2529.
- [14] Hull, J. C. and White, A., (1995) The impact of default risk on the prices of options and other derivative securities, *Journal of Banking & Finance* 19, 299-322.
- [15] Jarrow, R. A. and Turnbull, S. M., (1995) Pricing derivatives on financial securities subject to credit risk, *Journal of Finance* 50, 53-85.
- [16] Johnson, H. and Stulz, R., (1987) The pricing of options with default risk, *Journal of Finance* 42, 267-280.
- [17] Johnson, S. A. and Tian, Y. S., (2000) The value and incentive effects of nontraditional executive stock option plans, *Journal of Financial Economics* 57, 3-34.
- [18] Klein, P., (1996) Pricing Black-Scholes options with correlated credit risk, *Journal of Banking & Finance* 20, 1211-1129.
- [19] Klein, P. and Inglis, M., (2001) Pricing vulnerable European options when the option's payoff can increase the risk of financial distress, *Journal of Banking & Finance* 25, 993-1012.
- [20] Klein, P. and Yang, J., (2010) Vulnerable American options, *Managerial Finance* 36, 414-430.
- [21] Lambert, R. (1986) Executive effort and the selection of risky projects, *Rand Journal of Economics* 17, 77-88.
- [22] Lu, J., Chen, Y., Hwang, C., and Ting, Y., (2013) Valuing seller-defaultable options, *Journal of Futures Markets* 33, 129-157.
- [23] Merton, R. C., (1974) On the pricing of corporate debt: The risk structure of interest rates, *Journal of Finance* 2, 449-470.
- [24] Moraux, F., (2004) A Closed-form solution for pricing defaultable bonds. *Finance Research Letters* 1, 135-142.
- [25] Quintero, S. M., Young, L., and Baur, M., (1997) Executive stock options: Risk and incentives, *Journal of Financial and Strategic Decisions* 10, 59-74.
- [26] Tang, C. (2012) Revisiting the incentive effects of executive stock options, *Journal of Banking & Finance* 36, 564-574.
- [27] Uhrig-Homburg, M. (2002) Valuation of defaultable claims - A survey. *Schmalenbach Business Review* 54, 24-57.

[28] Ziegler, A., (2004) *A Game Theory Analysis of Options*, New York: Springer Publishers.

### Appendix

This Appendix presents the result of equation (4). By option pricing theory, the initial price of an executive stock option with default risk can be written as follows:

$$\begin{aligned}
 C_t &= e^{-r(T-t)} E^Q(C_T) \\
 &= e^{-r(T-t)} E^Q((S_T - K)I_1) + e^{-r(T-t)} E^Q\left(\frac{(1-\alpha)(S_T - K)V_T}{B + mV_T} I_2\right) \\
 &= e^{-r(T-t)} E^Q(S_T I_1) - e^{-r(T-t)} E^Q(KI_1) \\
 &\quad + e^{-r(T-t)} E^Q\left(\frac{(1-\alpha)S_T V_T}{B + mV_T} I_2\right) \\
 &\quad - e^{-r(T-t)} E^Q\left(\frac{(1-\alpha)KV_T}{B + mV_T} I_2\right) \\
 &= A_1 - A_2 + A_3 - A_4
 \end{aligned}$$

where,

$$\begin{aligned}
 A_2 &= e^{-r(T-t)} E^Q(KI_1) \\
 &= Ke^{-r(T-t)} E^Q(I_1) \\
 &= Ke^{-r(T-t)} P^Q[S_T \geq K, V_T \geq B + mV_T] \\
 &= Ke^{-r(T-t)} P^Q\left[\frac{dW^Q}{\sqrt{T-t}} \geq \frac{\ln(K/S_t) - (r - q - \sigma^2/2)(T-t)}{\sigma\sqrt{T-t}}, \right. \\
 &\quad \left. \frac{dZ^Q}{\sqrt{T-t}} \geq \frac{\ln(B/(1-m)V) - (r - \theta^2/2)(T-t)}{\theta\sqrt{T-t}}\right] \\
 &= Ke^{-r(T-t)} N(a_1, a_2; \rho)
 \end{aligned}$$

$$\begin{aligned}
 A_1 &= e^{-r(T-t)} E^Q(S_T I_1) \\
 &= S_t e^{-q(T-t)} E^Q(\xi_S I_1) \\
 &= S_t e^{-q(T-t)} E^R(I_1) \\
 &= S_t e^{-q(T-t)} P^R[S_T \geq K, V_T \geq B + mV_T] \\
 &= S_t e^{-q(T-t)} N(b_1, b_2; \rho)
 \end{aligned}$$

$$\begin{aligned}
 A_3 &= e^{-r(T-t)} E^Q\left(\frac{(1-\alpha)S_T V_T}{B + mV_T} I_2\right) \\
 &= e^{-r(T-t)} E^Q((1-\alpha)S_T H_T I_2) \\
 &= e^{-r(T-t)} E^Q((1-\alpha)S_t H_t I_2) * \\
 &\quad e^{(r-q-\sigma^2/2)(T-t) + \alpha dW^Q} e^{(r-y-\eta^2/2)(T-t) + \eta dW^Q} \\
 &= (1-\alpha)S_t H_t e^{(r-q-y+\rho\sigma\eta)(T-t)} E^Q(\xi_{S,H} I_2) \\
 &= \frac{(1-\alpha)S_t V_t}{B + mV_t} e^{(r-q-y+\rho\sigma\eta)(T-t)} E^R(I_2) \\
 &= \frac{(1-\alpha)S_t V_t}{B + mV_t} e^{(r-q-y+\rho\sigma\eta)(T-t)} N(c_1, c_2; -\rho)
 \end{aligned}$$

$$\begin{aligned}
 A_4 &= e^{-r(T-t)} E^Q\left(\frac{(1-\alpha)KV_T}{B + mV_T} I_2\right) \\
 &= (1-\alpha)Ke^{-r(T-t)} E^Q(H_T I_2) \\
 &= (1-\alpha)Ke^{-r(T-t)} E^Q(H_t e^{(r-y-\eta^2/2)(T-t) + \eta dW^Q} I_2) \\
 &= (1-\alpha)H_t Ke^{-y(T-t)} E^Q(\xi_H I_2) \\
 &= (1-\alpha)H_t Ke^{-y(T-t)} E^R(I_2) \\
 &= \frac{(1-\alpha)V_t K}{B + mV_t} e^{-y(T-t)} N(d_1, d_2; -\rho)
 \end{aligned}$$

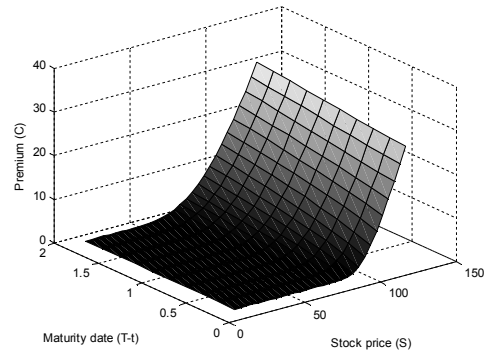
here,

$$H_t = \frac{V_t}{B + mV_t}$$

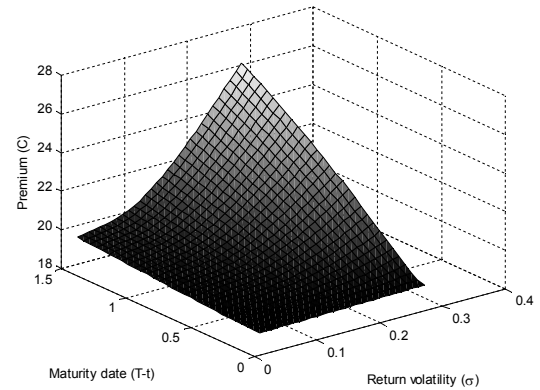
The closed-form solution (4) is naturally derived as follows:

$$\begin{aligned}
 C_t &= A_1 - A_2 + A_3 - A_4 \\
 &= S_t e^{-q(T-t)} N(b_1, b_2; \rho) - Ke^{-r(T-t)} N(a_1, a_2; \rho) \\
 &\quad + \frac{(1-\alpha)V_t}{B + mV_t} (S_t e^{(r-q-y+\rho\sigma\eta)(T-t)} N(c_1, c_2; -\rho) \\
 &\quad - Ke^{-y(T-t)} N(d_1, d_2; -\rho))
 \end{aligned}$$

**Figure 1. Option Values Vary with Stock Prices and Return Volatilities**



Panel A: Varying with stock prices

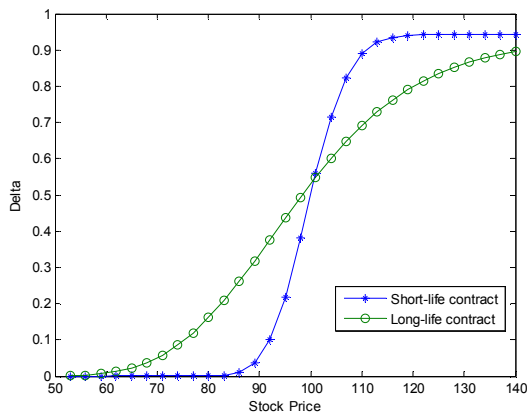




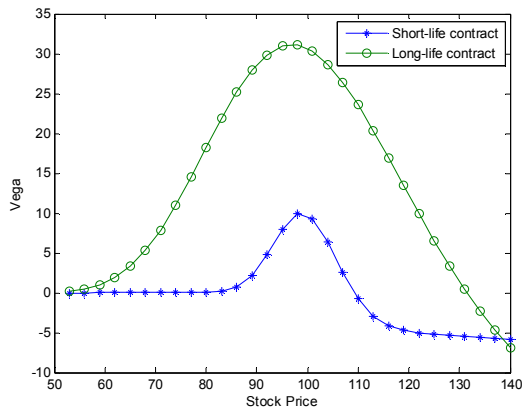
Panel B: Varying with return volatilities

The figure displays default probabilities of ESOs with a default risk varying with stock price and volatility rate. Parameters are given as follows: initial stock price of  $S = \$120$ , strike price of  $K = \$100$ , risk free rate of  $r = 3\%$ , dividend yield of  $q = 2\%$ , time to maturity of  $\tau = 1$  year, return volatility of stock price of  $\sigma = 20\%$ , debt boundary of  $B = \$450$ , firm value of  $V = \$500$ , return volatility of firm value of  $\theta = 10\%$ , salary policy of  $m = 10\%$ , coefficient of correlation of  $\rho = 0.5$ , and dead-weight cost of  $\alpha = 10\%$ .

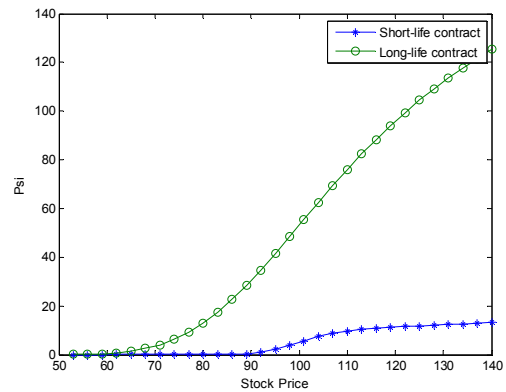
Figure 2. Greeks of Executive Stock Options with Writer's Default



Panel A: Delta



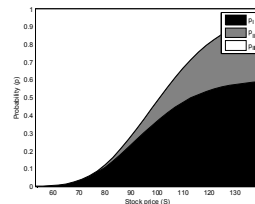
Panel B: Vega



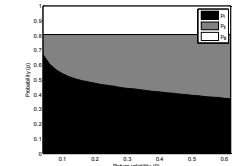
Panel C: Psi

The figure displays Greeks of ESOs with a default risk varying with stock prices. Short-life contract and long-life contract have times to maturity of  $\tau = 0.1$  and 1 years, respectively. Parameters are given as follows: initial stock price of  $S = \$120$ , strike price of  $K = \$100$ , risk free rate of  $r = 3\%$ , dividend yield of  $q = 2\%$ , return volatility of stock price of  $\sigma = 20\%$ , debt boundary of  $B = \$450$ , firm value of  $V = \$500$ , return volatility of firm value of  $\theta = 10\%$ , salary policy of  $m = 10\%$ , coefficient of correlation of  $\rho = 0.5$ , and dead-weight cost of  $\alpha = 10\%$ .

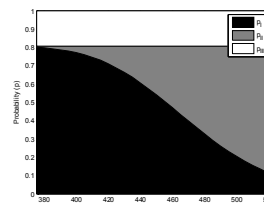
Figure 3. Cumulative Probabilities



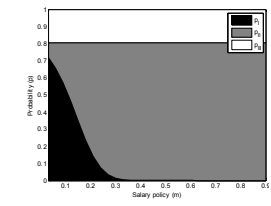
Panel A: Varying with stock prices



Panel B: Varying with return volatilities of firm value



Panel C: Varying with debt boundaries

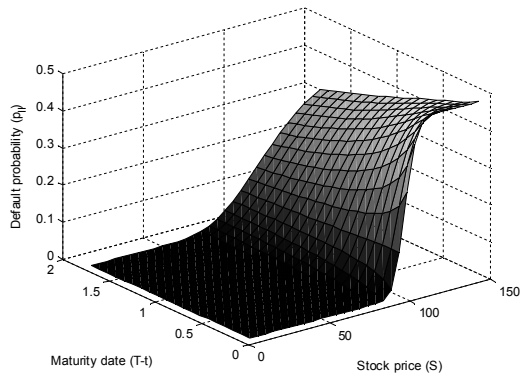


Panel D: Varying with salary policies

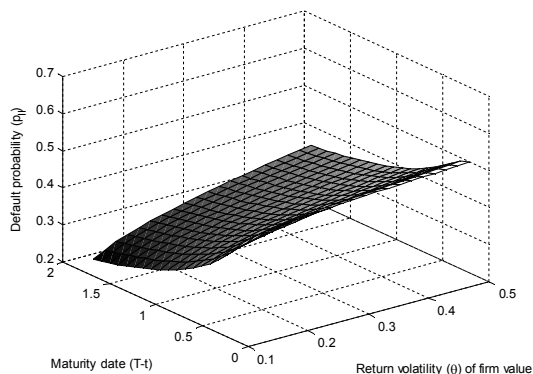
The figure displays how cumulative full-payable probabilities, default probabilities, non-exercisable probabilities of ESOs with a default risk vary with various factors. Parameters are given as follows: initial stock price of  $S = \$120$ , strike price of  $K = \$100$ , risk free rate of  $r = 3\%$ , dividend yield of  $q = 2\%$ , time to

maturity of  $\tau = 1$  year, return volatility of stock price of  $\sigma = 20\%$ , debt boundary of  $B = \$450$ , firm value of  $V = \$500$ , return volatility of firm value of  $\theta = 10\%$ , salary policy of  $m = 10\%$ , coefficient of correlation of  $\rho = 0.5$ , and dead-weight cost of  $\alpha = 10\%$ .

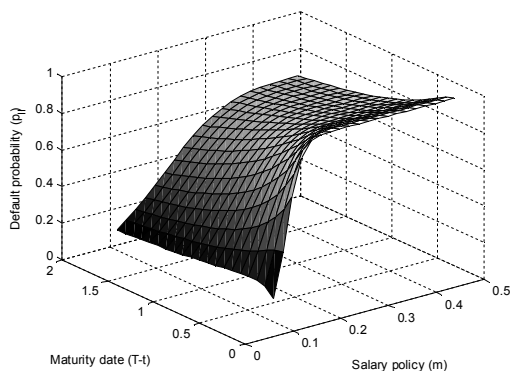
**Figure 4. Default Probability**



Panel A: Stock price ( $S$ )



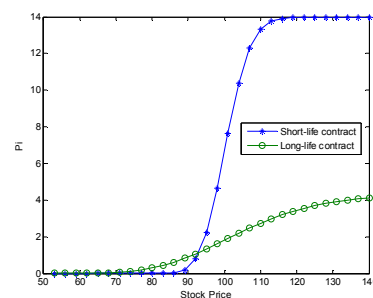
Panel B: Return volatility ( $\theta$ ) of firm value



Panel C: Salary policy ( $m$ )

The figure displays default probabilities of ESOs with a default risk varying with stock price and time to maturity. Parameters are given as follows: initial stock price of  $S = \$120$ , strike price of  $K = \$100$ , risk free rate of  $r = 3\%$ , dividend yield of  $q = 2\%$ , time to maturity of  $\tau = 1$  year, return volatility of stock price of  $\sigma = 20\%$ , debt boundary of  $B = \$450$ , firm value of  $V = \$500$ , return volatility of firm value of  $\theta = 10\%$ , salary policy of  $m = 10\%$ , coefficient of correlation of  $\rho = 0.5$ , and dead-weight cost of  $\alpha = 10\%$ .

**Figure 5. Greeks of Default Probability**



The figure shows  $\pi$  of default probabilities of ESOs with a default risk varying with stock price. Short-life contract and long-life contract have times to maturity of  $\tau = 0.1$  and 1 years, respectively. Parameters are given as follows: initial stock price of  $S = \$120$ , strike price of  $K = \$100$ , risk free rate of  $r = 3\%$ , dividend yield of  $q = 2\%$ , return volatility of stock price of  $\sigma = 20\%$ , debt boundary of  $B = \$450$ , firm value of  $V = \$500$ , return volatility of firm value of  $\theta = 10\%$ , salary policy of  $m = 10\%$ , coefficient of correlation of  $\rho = 0.5$ , and dead-weight cost of  $\alpha = 10\%$ .

**Table 1. Option Premiums**

The table reports option premiums of ESOs with default risk varying with various factors. Parameters are given as follows: initial stock price of  $S = \$120$ , strike price of  $K = \$100$ , risk free rate of  $r = 3\%$ , dividend yield of  $q = 2\%$ , time to maturity of  $\tau = 1$  year, return volatility of stock price of  $\sigma = 20\%$ , debt boundary of  $B = \$450$ , firm value of  $V = \$500$ , return volatility of firm value of  $\theta = 10\%$ , salary policy of  $m = 10\%$ , coefficient of correlation of  $\rho = 0.5$ , and dead-weight cost of  $\alpha = 10\%$ .

		Panel A: Stock price ( $S$ )					
Ti							
me ( $\tau = T-t$ )		\$ 70	\$ 80	\$ 90	\$ 100	\$ 110	\$ 120
	0.2	0	0	0	3	1	1

	0	1	2	3	4	5
	0%	5%	0%	5%	0%	5%
5 year	.0004	0424	.7333	9857	0.7022	9.4044
0.5	0	0.	1	5.	1	2
0 year	.0243	3288	.8306	6743	2.0413	0.1264
0.7	0	0.	2	6.	1	2
5 year	.1148	7676	.8247	9753	3.1968	0.9213
1.0	0	1.	3	8.	1	2
0 year	.2724	2626	.7204	0717	4.2145	1.7019
Panel B: Return volatility ( $\sigma$ )						
	1	1	2	2	3	3
	0%	5%	0%	5%	0%	5%
0.2	1	1	1	1	2	2
5 year	9.1116	9.2146	9.4044	9.7362	0.2079	0.7950
0.5	1	1	2	2	2	2
0 year	9.2976	9.5759	0.1264	0.9217	1.8932	2.9864
0.7	1	2	2	2	2	2
5 year	9.5095	0.0231	0.9213	2.0941	3.4433	4.9062
1.0	1	2	2	2	2	2
0 year	9.7427	0.4992	1.7019	3.1861	4.8399	6.5988
Panel C: Salary policy ( $m$ )						
	0	5	1	1	2	2
	%	%	0%	5%	0%	5%
0.2	2	2	1	1	1	1
5 year	0.2759	0.1347	9.4044	8.0533	6.9627	6.1918
0.5	2	2	2	1	1	1
0 year	0.9133	0.7212	0.1264	9.0639	7.9268	7.0279
0.7	2	2	2	2	1	1
5 year	1.6529	1.4457	0.9213	0.0121	8.9253	7.9503
1.0	2	2	2	2	1	1
0 year	2.3932	2.1813	1.7019	0.8903	9.8653	8.8611
Panel D: Debt boundary ( $B$ )						

	3	4	4	4	4	4
	90	10	30	50	70	90
0.2	2	2	2	1	1	1
5 year	0.2853	0.2630	0.0677	9.4044	8.3595	7.3956
0.5	2	2	2	2	1	1
0 year	0.9451	0.8840	0.6531	0.1264	9.3297	8.4458
0.7	2	2	2	2	2	1
5 year	1.6996	1.6145	1.3796	0.9213	0.2479	9.4549
1.0	2	2	2	2	2	2
0 year	2.4487	2.3491	2.1170	1.7019	1.1053	0.3845
Panel E: Dividend rate ( $q$ )						
	0	1	2	3	4	5
	%	%	%	%	%	%
0.2	1	1	1	1	1	1
5 year	9.9545	9.6789	9.4044	9.1311	8.8588	8.5878
0.5	2	2	2	1	1	1
0 year	1.1711	0.6461	0.1264	9.6121	9.1032	8.6000
0.7	2	2	2	2	1	1
5 year	2.4309	1.6700	0.9213	0.1850	9.4614	8.7506
1.0	2	2	2	2	1	1
0 year	3.6617	2.6711	1.7019	0.7543	9.8287	8.9253
Executive's incentive effects						

**Table 2. Executive's Incentives in an Option Analysis of Games**

The table displays incentive effects of ESOs holders varying with various strategies of board of directors. Parameters are given as follows: initial stock price of  $S = \$120$ , strike price of  $K = \$100$ , risk free rate of  $r = 3\%$ , dividend yield of  $q = 2\%$ , time to maturity of  $\tau = 1$  year, return volatility of stock price of  $\sigma = 20\%$ , debt boundary of  $B = \$450$ , firm value of  $V = \$500$ , return volatility of firm value of  $\theta = 10\%$ , salary policy of  $m = 10\%$ , coefficient of correlation of  $\rho = 0.5$ , and dead-weight cost of  $\alpha = 10\%$ .

Board of directors' strategies	Incentive to increase stock return volatility			Incentive to reduce dividend policy ( <i>Psi</i> )
	Incentive to increase stock price ( <i>Delta</i> )	Incentive to increase stock return volatility ( <i>Vega</i> )	Incentive to increase stock return volatility ( <i>Vega</i> )	
Panel A: Using strike price				
$K = \$80$	0.910	-	9.9369	109.2
$K = \$90$	0.875	-	1.5073	105.0
$K = \$100$	0.798	12.2	584	95.84
$K = \$110$	0.677	26.9	208	81.32
$K = \$120$	0.530	36.7	595	63.64
Panel B: Adjusting maturity date				
0.50 year	0.861	1.52	39	51.70
0.75 year	0.825	7.21	34	74.25
1.00 year	0.798	12.2	584	95.84
1.25 year	0.779	16.7	247	116.8
1.50 year	0.763	20.7	262	137.4
Panel C: Changing salary policy				
$m = 0\%$	0.832	22.3	017	99.95
$m = 10\%$	0.798	12.2	584	95.84
$m = 20\%$	0.724	12.7	059	86.96
$m = 30\%$	0.657	20.7	580	78.86
$m = 40\%$	0.605	20.5	164	72.63

**Table 3. Default Probability**

The table reports default probabilities of ESOs with a default risk varying with various factors. Parameters are given as follows: initial stock price of  $S = \$120$ , strike price of  $K = \$100$ , risk free rate of  $r = 3\%$ , dividend ratio of  $q = 2\%$ , time to maturity of  $\tau = 1$  year, return volatility of stock price of  $\sigma = 20\%$ , debt boundary of  $B = \$450$ , firm value of  $V = \$500$ , return volatility of firm value of  $\theta = 10\%$ , salary policy of  $m = 10\%$ , coefficient of correlation of  $\rho = 0.5$ , and dead-weight cost of  $\alpha = 10\%$ .

Time	Panel A: Initial stock price				
	\$50	\$70	\$90	\$110	\$130
0.50 year	0.00%	0.00%	0.11%	0.80%	2.297%
1.00 year	0.00%	0.01%	0.58%	0.77%	5.784%
1.50 year	0.00%	0.04%	0.03%	0.92%	5.517%
Panel B: Return volatility					
	5%	10%	15%	20%	25%
0.50 year	2.98%	2.57%	9.34%	4.79%	0.74%
1.00 year	0.12%	7.56%	1.62%	6.63%	2.99%
1.50 year	7.91%	3.25%	6.70%	2.07%	8.90%
Panel C: Debt payments					
	\$400	\$420	\$440	\$460	\$480
0.50 year	1.84%	8.54%	4.11%	6.21%	6.79%
1.00 year	3.58%	9.65%	0.06%	3.73%	8.04%
1.50 year	4.27%	9.40%	7.26%	7.29%	8.20%
Panel D: Return volatility					
	5%	10%	15%	20%	25%
0.50 year	6.91%	4.79%	7.99%	9.94%	1.37%
1.00 year	7.42%	6.63%	0.61%	3.07%	4.91%
1.50 year	2.46%	2.07%	6.50%	9.29%	1.38%
Panel E: Dividend					

		rate				
		0	1	2	3	4
		%	%	%	%	%
0.		3	3	3	3	3
50		5.66	5.24	4.79	4.34	3.87
year		%	%	%	%	%
1.		2	2	2	2	2
00		8.19	7.42	6.63	5.82	4.99
year		%	%	%	%	%
1.		2	2	2	2	2
50		4.04	3.07	2.07	1.07	0.05
year		%	%	%	%	%

		Panel F: Salary policy				
		5	1	1	2	2
		%	0%	5%	0%	5%
0.		1	3	6	8	8
50		2.44	4.79	3.60	2.72	8.69
year		%	%	%	%	%
1.		1	2	4	6	7
00		2.48	6.63	5.60	3.53	4.87
year		%	%	%	%	%
1.		1	2	3	5	6
50		1.60	2.07	6.28	1.51	3.94
year		%	%	%	%	%

**Table 4. Firm's defaults in an Option Analysis of Games**

The table presents default effects of ESOs writers varying with various strategies of executive. Parameters are given as follows: initial stock price of  $S = \$120$ , strike price of  $K = \$100$ , risk free rate of  $r = 3\%$ , dividend yield of  $q = 2\%$ , time to maturity of  $\tau = 1$  year, return volatility of stock price of  $\sigma = 20\%$ , debt boundary of  $B = \$450$ , firm value of  $V = \$500$ , return volatility of firm value of  $\theta = 10\%$ , salary policy of  $m = 10\%$ , coefficient of correlation of  $\rho = 0.5$ , and dead-weight cost of  $\alpha = 10\%$ .

Board of director's default effects

Executive' strategies	Incentive to changing salary policy ( $P_i$ )
Panel A: Using strike price ( $K$ )	
$K = \$80$	4.2266
$K = \$90$	3.9857
$K = \$100$	3.4478
$K = \$110$	2.6552
$K = \$120$	1.8042
Panel B: Adjusting maturity date ( $T-t$ )	
$T-t = 0.50$ year	5.6211
$T-t = 0.75$ year	4.2546
$T-t = 1.00$ year	3.4478
$T-t = 1.25$ year	2.9087
$T-t = 1.50$ year	2.5201
Panel C: Changing effort for increasing stock price ( $S$ )	
$S = \$80$	0.2924
$S = \$100$	1.8042
$S = \$120$	3.4478
$S = \$140$	4.1207
$S = \$160$	4.2705
Panel D: Changing effort for increasing stock volatility ( $\sigma$ )	
$\sigma = 5\%$	4.2963
$\sigma = 15\%$	3.8421
$\sigma = 25\%$	3.1175
$\sigma = 35\%$	2.6352
$\sigma = 45\%$	2.3011
Panel E: Changing dividend policy ( $q$ )	
$q = 0\%$	3.5788
$q = 1\%$	3.5150
$q = 2\%$	3.4478
$q = 3\%$	3.3772
$q = 4\%$	3.3033

# Challenges in Justifying Qualitative Case Studies in Social Science Research

Shahid Ali

Enterprise Architecture Consultant at NCEI, SA  
[shahidwahidali@gmail.com](mailto:shahidwahidali@gmail.com)

## Abstract

*Selection of a research methodology should be driven by the research problem and the purpose of the study. Instead, a number of researchers pre-decide in favor of quantitative approach irrespective of nature of research problem and the purpose of the study. The main reason is the challenges faced by researchers in performing qualitative research. Justification of a qualitative case study poses additional challenges. The paper provides a completed research problem and the purpose of study and demonstrates the scholarly reasoning for the selection of qualitative approach, case study, selection of a particular case, and the population size. The research contributes to the selection of appropriate research methods for researchers by presenting a scholarly and step-by-step approach in the context of a specific research problem.*

## 1. Introduction

The focus of the paper is to justify the research design that would best address the research problem, and to discuss the appropriateness of the selected research design and research method that will address the problem statement. According to Zikmund [1], a research *design* “is a framework or blueprint that plans the action for the research project” (p. 65). According to Lincoln and Guba (1985), “design in the naturalistic sense ... means planning for certain broad contingencies without, however, indicating exactly what will be done in relation to each” (as cited in [2], p. 254). The detailed procedures of data collection, analysis, and writing are called *methods*[3]. According to Creswell [3], three *approaches* to research are quantitative, qualitative, and mixed methods. Sometimes the term *inquiry* is also used instead of the term approach [2, 3].

Quantitative research requires developing numeric measures of observations and is thus based on the concept of simplification or abstraction of entity into variables. Quantitative research is also considered

deterministic in the sense causes determine the effects. Quantitative research has hypothesis (a proposition that is empirically testable) and thus involve theory verification. Qualitative research is interpretive and uses complex reasoning. Qualitative research involves understanding or making sense of the data collected and theory development.

The paper provides a systematic way of justifying qualitative case study for a specific research problem. A popular research approach among researchers is quantitative and the most obvious choice for data collection is survey/questionnaire. Research questions, hypotheses, data analysis and generalization pose few, if any, problems in pursuing the quantitative research and are also well understood. The paper uses a completed research problem and the purpose of study and demonstrates the scholarly reasoning for the selection of qualitative case study. Issues of generalization in case study and triangulation are also presented in the context of the topic. The paper concludes the results of qualitative research are viewed by other researchers using the “quantitative lens.” Concerns are raised about reliability, validity and generalization. The reliability and validity of qualitative case study depends on proper justification for the selection of qualitative study, population, generalization, data triangulation, limitations and documentation of data analysis process. Purposeful sampling and the selection of an information rich case play an important role in qualitative case studies. The paper is also an attempt to promote the use of qualitative approach in general and qualitative case study in particular. Through the presentation of a complete qualitative landscape, a concrete qualitative case study is justified in the context of knowledge claims, strategies of inquiry, and research methods.

## 2. Research area

Business and information technology (IT) alignment remains a topic of interest among

researchers due to the benefits associated with alignment. Enterprise architecture (EA) is an emerging discipline with business and IT alignment as one of the most important benefits. Enterprise architecture framework acts as a guidebook for building and maintaining the EA. Business and IT alignment can be considered as a problem, and EA can be considered as a tool to solve the problem of business and IT alignment using an EA framework as a structured approach to the solution.

### 3. Research problem and purpose statements

Enterprise architecture intended benefits include the alignment of information systems with the business goals [4, 5] and, hence, the EA framework not only acts as a guidebook for building and maintaining the EA, but it is also critical for achieving the business and IT alignment through EA.

The *problem* addressed within the study was the deficiency of EA frameworks to offer value towards improved business and IT alignment [6]. Although, the problem is generalized to all or most EA frameworks, the *purpose* of the study was to conduct an in-depth exploration of the value a selected EA framework provides in aligning business and IT and to present potential recommendations for an improved EA framework for business and IT alignment.

Gregor et al. [6] have analyzed a *custom* EA framework for enabling alignment using a qualitative approach and have indicated the need for further research on *standard* EA frameworks for enabling alignment. In the study, a custom EA framework is distinguished from a standard EA framework. A custom EA framework is either a framework developed specifically for an organization or a customized standard framework to satisfy specific requirements of an organization. The information about standard EA frameworks is normally available publicly. The study involved exploration of a standard EA framework for the specified problem.

### 4. Justifying research design

The framework for research design as presented by Creswell [3] was used in the study. The selection of qualitative approach and case study are justified using the framework guidelines. Essentials of the framework are discussed in the section in the context of the research problem, purpose and research questions. Creswell [3] described three *elements of inquiry*: knowledge claims, strategies of inquiry, and research methods. According to Creswell [3], these elements

provide different approaches to research. Knowledge claims element relate to the philosophical assumptions [3]. Strategies of inquiry are general procedures of research [3]. Research methods are detailed procedures of data collection, analysis, and writing [3]. By considering the three elements of inquiry, a researcher can identify one of the three approaches to inquiry, namely, quantitative, qualitative, and mixed method. Considerations of the three elements of inquiry as discussed in the next paragraphs led to the selection of a qualitative approach to research for the study.

In the qualitative approach, researchers use constructivist or participatory claims or both; strategies of inquiry such as grounded theory, case study, ethnography, phenomenology, or narrative; and data collection methods based on observations, interviewing, open-ended questions, document data or emerging methods [2, 3]. Careful study of the three elements of inquiry as provided by Creswell [3] led to the conclusion that the knowledge claims for the study to be based on constructivist approach. Among the relevant strategies of inquiry, the case study was used. The data collection method was based on the document data [3, 7]. The following paragraphs discuss why the constructivist approach and case study were optimal choices for the study. The selection of document data as the data collection method is justified in the section 7.

In constructivism or socially constructed knowledge claims, the researchers aim to interpret the meanings others have about the world and try to inductively develop a theory or pattern of meaning [3]. Thus, the qualitative research is mainly inductive. Since, the problem addressed within the study was the deficiency of EA frameworks to offer value towards improved business and IT alignment, an inductive approach was suitable. An EA framework was analyzed to develop a pattern of meaning to help answer the research questions.

Considerations leading to the choice of case study as the strategy of inquiry are discussed in remaining part of the section by citing from authoritative sources on case study. A case study is an in depth study of a single object [3, 8]; the object to be studied is similar to the researcher's problem situation [1]. In the study, the problem situation was the EA frameworks and the selected standard EA framework was the unit of analysis for the qualitative case study [9]. The object in a case study can be a program, an event, an activity, or a process [3]. The selected EA framework can be considered both a program and a process.



According to Yin [9], researchers use case study to investigate a phenomenon in depth within its context and the use of case study allows the researchers to retain the holistic and meaningful characteristics of the phenomenon. The phenomenon in the study was EA frameworks and the selected standard EA framework was the unit of analysis for the qualitative case study. Since the purpose of the qualitative case study was to conduct an in-depth exploration of the value the selected EA framework provides in aligning business and IT and to present potential recommendations for an improved EA framework for business and IT alignment, the framework needed to be studied in its entirety and not any of the framework's specific implementation in an organization.

The main benefit of case study is an entity can be investigated in depth, and such an in-depth study allows the researcher to focus and discover the relationships among functions and entities [1]. The study discovered the linkages or relationships the framework provided for aligning the business and IT. Advocating the use of case study as an appropriate strategy of inquiry for certain research problems, Smith [10] argued "case studies need not be viewed as solely exploratory or tentative exercises in research" (p. 131). Smith [10] further elaborated that "their validity, when correctly understood, depends ... on how they are used and the logic of their analysis" (p. 131). According to Yin [9], the case studies can be exploratory, descriptive, and explanatory. Case study is particularly suited when a contemporary object is to be studied on which the researcher has little control [9]. All of the characteristics of case study discussed above led to the choice of case study method for the study. The selected EA framework was a contemporary object and the study was exploratory as characterized by the central research question.

Cepeda and Martin [11] argued a case study strategy is well suited to capturing the knowledge of practitioners and is an appropriate way to explore areas where research studies are scarce. Sage [12] indicated a lack of research basis in EA, and thus the case study was particularly suited for the study [11]. Additionally, the contemporary work in EA frameworks was mainly the work of practitioners, and the case study was an appropriate method for the identified research problem.

## 5. Developing research questions

In the context of the research problem and to achieve the purpose of the study, some research questions were developed that were consistent with the

emerging methodology of qualitative research [3]. Creswell [3] has provided detailed guidelines for the development of qualitative research questions. According to Creswell, in a qualitative study, only the central research question and associated sub-questions are stated. The qualitative research questions should be broad and general. Creswell [3] recommended focusing on a single phenomenon or concept, and use of non-directional language in developing research questions. The Creswell's [3] guidelines were adopted in the formulation of the research questions for the study.

The central research question of the qualitative case study was: What value does the selected EA framework provides in aligning the business and IT? Based on the central research question, the following research sub-questions were developed for the qualitative case study:

Q1. What are the existing linkages in the selected EA framework for business and IT alignment?

Q2. What are the deficiencies in the linkages in the selected EA framework for business and IT alignment?

Q3. How can the selected EA framework be improved for business and IT alignment by addressing the identified deficiencies?

The central research question is broad and general and is consistent with emerging method of qualitative research. Each of the sub-questions are focused on a single concept (existing linkages, deficiencies in linkages and addressing the identified deficiencies). The emerging method of the qualitative approach is to be contrasted with predetermined hypotheses of the quantitative approach. The emerging methodology allow the patterns to emerge during data collection and analysis.

## 6. Justifying participants and materials selection

Qualitative study is usually an in depth study. The number of samples used in a qualitative study is usually small to allow in depth study. Thus, the samples in the qualitative study were selected purposefully rather than randomly as in the quantitative studies [2, 3, 7, 13]. A qualitative researcher purposefully selects participants, sites, documents or visual materials to understand the problem and get answers to the research questions in the best possible manner [3]. In the context of case study, Patton [2] referred to the purposeful sampling as the selection of information rich cases and provided the same reasoning as Creswell [3]. For the qualitative study in

discussion, the population group was a purposefully selected case [2].

A standard EA framework was selected as the unit of analysis for the qualitative case study. The selected standard EA framework was an information rich case and helped in illuminating the research questions under study [2]. Since, the data collection method was based on the archival document data (documents explaining the selected standard EA framework), it provided thoughtful source of data from the participants, the group of people who developed and documented the selected standard EA framework, without researcher's involvement [3] and the study was not restricted to a particular geographic location. The results of the study are helpful to both researchers and practitioners in the fields of enterprise architecture and business and IT alignment irrespective of the geographic location.

A careful investigation was required before selecting the case so as to avoid misrepresentation and committing early to a specific case in the research design [9]. Patton [2] discussed 15 purposeful sampling strategies and Yin [9] provided five rationales for selecting a case. One of the strategies of case selection is typical case sampling in which a case is selected because it illustrates what is typical, normal, or average, and is not in any major way atypical, extreme, deviant, or intensely unusual [2, 9]. The selected EA framework was a standard EA framework as opposed to a custom EA framework. The selected standard EA framework was applicable to a wide variety of organizations, and was broadly used. The selection of the standard EA framework is an example of a typical case which is not customized for a specific organization and is thus not in any way atypical, extreme, deviant, or intensely unusual. Another strategy for case selection is selection of a politically important case to attract attention to the study and to increase its usefulness and relevance [2]. The selected standard EA framework is widely used in all types of organizations throughout the world, and a study of the selected standard EA framework will attract attention and increase the applicability of the results of study.

In the context of the study, the identified research problem was investigated by using the selected standard EA framework as a case study. A case study of a standard EA framework in the context of the problem helped address the qualitative research questions for the study. Since the selected EA framework for the case study was a standard and publicly available framework, the access to the relevant information was available to get answers to the research questions.

## **7. Justification of research method: Data collection, processing, and analysis**

Creswell [3] described three elements of inquiry: knowledge claims, strategies of inquiry, and research methods. Knowledge claims element relate to the philosophical assumptions [3]. Strategies of inquiry are general procedures of research [3]. Research methods are detailed procedures of data collection and analysis. The discussion on knowledge claims and strategies of inquiry is covered in earlier sections. This section provides justification of the research method selection.

In accordance to Creswell [3] framework for research design, the research method refer to detailed procedures of data collection and analysis. The data collection for the study in discussion was based on archival documents. The use of archival documents as the data collection method is first justified in the section. The details of data processing and analysis are then discussed. Guidelines and process of qualitative data analysis used for the study are presented and justified by citing authoritative sources. The importance of researcher's role in the qualitative data analysis is also highlighted.

One of the data collection procedures in qualitative studies is the use of documents [3, 7, 9]. Silverman and Marvasti [7] used the term text instead of documents and defined it as "a heuristic device to identify data consisting of words and images that have become recorded without the intervention of a researcher" (p. 74). According to Yin [9], "documents play an explicit role in any data collection in doing case studies" (p. 103).

In the context of the study, the use of archival documents was the correct data collection method for the identified research problem. A standard EA framework was used as the unit of analysis. The framework documents were analyzed to obtain answers to the research questions. Sources of data depend on the research questions and objectives of the study [2]. No right or wrong data collection methods exist and the data collection methods should be appropriate to the research topic [7]. The use of the framework documents as the data source helped in an in-depth exploration of the value the framework offers towards business and IT alignment. Such an in-depth exploration was not possible with any other data source because the potential of the selected framework towards aligning business with IT had not been explored in any other study. The data should be limited for effective analysis when the use of documents is selected as a data collection method.

One source of data was also considered appropriate for the case study and had been articulated by case study researchers [14]. Additionally, the purpose of the study was to explore the selected standard EA framework in its entirety. In most cases, the use of the standard EA framework in organizations is customized [15]. Thus, any other data collection method would have failed to satisfy the purpose of the study.

Qualitative data analysis is neither prescriptive nor mechanical [13]. Although, no formula or recipe exists for transforming qualitative data into findings; guidelines for qualitative data analysis are available [2]. Rigorous thinking, presentation of evidence, and careful consideration of alternative interpretations were important in qualitative data analysis in the study [9]. "Qualitative designs continue to be emergent even after data collection begins" [2, p. 255].

The data was analyzed as it was gathered in the light of the research questions rather than waiting for the completion of data gathering process [7]. Analytical insights were recorded and tracked during data collection as part of preliminary qualitative data analysis [2]. The researcher did not start with categories at the outset and allowed such categories to emerge as part of the data analysis process. The application of the guidelines required judgment and creativity because each qualitative study is unique. The qualitative data analysis techniques were not easy to use, and were learned over a period of time [9].

Qualitative inquirers specify a generic process of data analysis [3]. Specification of a generic process or plan early in the research for qualitative data analysis was helpful. Creswell's [3] six step generic process for qualitative data analysis was followed for data analysis in the study. The six steps of Creswell's [3] generic process are (a) organizing and preparing data for analysis, (b) preliminary analysis or making general sense of the data, (c) coding or categorization and labeling of data, (d) creating description of categories to generate small number of themes, (e) use of tables or drawings or process models to represent themes, and (f) making interpretation and meaning of data.

Yin [9] has also presented the development of such a descriptive framework as one of the strategies of data analysis for a case study. Shank [13] outlined a four phase qualitative data analysis approach that is similar to Creswell's [3] generic approach, and mentioned the development of categories and themes as part of the phases. Creswell [3] has provided some guidelines for the coding step in the generic data analysis process for analyzing documents data.

Creswell's [3] coding guidelines were used as part of the data analysis steps in the study. The coding

guidelines provided by Creswell [3] are (a) develop a sense of the whole data, (b) get to the underlying meaning of the document and not just its substance, (c) form a list of topics and group similar topics together into categories, (d) label the data with topic codes to help emergence of new categories and new topics, (e) develop interrelationships between categories, (f) finalize and arrange codes, (g) perform preliminary analysis on the categories, and (h) recode the existing data as necessary. The coding guidelines were used in data analysis for the study in discussion. During data analysis, the point of interest was to discover the linkages within the selected EA framework contributing to business and IT alignment. The discovery of these linkages followed the process of data analysis and coding guidelines outlined above. Different types of linkages or relationships were discovered during data analysis. A comprehensive coding scheme was devised to identify each linkage uniquely.

The six step data analysis process and coding guidelines helped in systematic analysis of data and contributed to the quality of research. The six step data analysis process was used mainly for first research sub-question. Researcher's knowledge and experience were important factors in the findings of the other research questions. Triangulation strengthens a study by combining methods or data [2]. The main source of data was EA framework documentation, but researcher's perspective based on knowledge and experience in the area of research, and other researchers' perspective acquired from the literature on EA, EA frameworks, and business and IT alignment, lead to data triangulation. The development of themes during data analysis were influenced by the triangulation.

## **8. Challenges in achieving and justifying quality in qualitative case study**

Quality is an important aspect in research. Silverman and Marvasti [7] and Shank [13] have advocated the notions of reliability and validity to help establish the quality of qualitative research. Yin [9] has also used the terms reliability and validity to judge the quality of case studies. Reliability and validity have different meanings in qualitative approach as compared to the quantitative approach [3]. The notions of reliability and validity were used to establish the quality of the results of qualitative research presented in the paper. Reliability and validity as used in qualitative research and within the context of the study are discussed in the following paragraphs.

Validity is the same as truth [7]. Validity means the description of the observation accurately represents the event [16]. In qualitative approach, the role of researcher or observer is important. In adopting a qualitative approach to the study, the researcher's own experience and background is crucial in the context of interpretation during data analysis. Some risks are associated with the freedom and flexibility a researcher has in case studies [1]. According to Zikmund [1], researcher's creativity, intelligence and level of concentration have a major role in the success of a case study. Smith [10] also mentioned the problem of dependence on researcher's skills in case studies. Thus, in order to record the truth, "the stance of the observer needs to be made explicit" [10, p. 111]. According to Creswell [3], validity in qualitative research is used to determine not only whether the results are accurate from the standpoint of the readers, but also from the standpoint of the researcher and the participants. In the context of the qualitative research design using case study and data collection method based on documents, the validity was established by ensuring the inference or understanding developed from the documents was accurate as intended by the author of the document. Complete EA framework documentation was read and analyzed multiple times to ensure the inference or understanding developed from the documents was accurate. Any specific standpoints of the researcher were made explicit.

Reliability is relevant in qualitative data analysis. Reliability refers to the degree of consistency in using researcher defined categories and the accuracy of the documented procedures to reach the results of the study [7]. Thus, a later investigator can use the same set of procedures and categories to arrive at the same findings [9]. According to Yin [9], "the goal of reliability is to minimize the errors and biases in a study" (p. 45). In the context of the study, the reliability was established by accurately documenting the procedures used to reach the results of the study.

### **9. Mentioning the limitations and assumptions in qualitative case study**

Assumptions, limitations and delimitations in the context of the study and chosen research design and method are clearly identified in the section. There have been some concerns of generalizations based on case studies' results, and researchers have differing views on the use of case studies for generalization [7, 13, 17]. Flyvbjerg [17] and Smith [10] have argued the results of case studies can be generalized. Mitchell (1983) discussed the irrelevance of representativeness in case

studies and stated: "The process of inference from case studies is only logical or causal and cannot be statistical and extrapolability from any one case study to like situations in general is based only on logical inference. We infer that the features present in the case study will be related in a wider population not because the case is representative but because our analysis is unassailable." (as cited in [10], p. 129)

Thus, the basis of generalization from case studies stems from analysis, articulation, and logical connections and not on representativeness of the case study [10]. Hence, analysis was important in the case study. Document analysis required the ability to read between the lines to discover hidden meanings [17]. In the context of generalization, the results of the study are not directly generalizable to other EA frameworks. The results indicate some patterns which can be tested against other EA frameworks. Thus, other similar studies in future will be able to benefit from the results of the study.

The use of archival documents was selected as the data collection method for the identified research problem. Yin [9] has identified some strengths and weaknesses of using documents as a data collection method. Strengths include the ability to be reviewed repeatedly, unobtrusiveness, exactness, and broad coverage [9]. Weaknesses include retrievability, biased selectivity, reporting bias, and accessibility. Since the EA framework analyzed for business and IT alignment was one of the standard EA frameworks (as opposed to a custom EA framework), no issue existed regarding retrievability and accessibility as the related documentation of the selected EA framework was available in public domain. Reporting bias issue did not arise since the framework is what is actually written in the documents describing the framework. Since the selected EA framework is a standard EA framework and has large user community, the selection did not raise the biased selectivity issue. However, using published research as a reference about the framework needed care as there was possibility of reporting bias and biased selectivity issue.

Creswell [3] has also mentioned some advantages and limitations of using documents as a data collection method. Some of the advantages and limitations are the same as mentioned by Yin [9]. According to Creswell [3], document "enables a researcher to obtain the language and words of the participants [for example, the community that developed the EA framework]" (p. 187). Creswell [3] also mentioned that documents "represents data that are thoughtful, in that participants have given attention to compiling" (p. 187). The selected EA framework document are

thoughtful and carefully compiled. In contrast, the data collected based on survey within an organization using the selected EA framework is usually not thoughtful resulting in rejection of some of the collected survey data. Silverman and Marvasti [7] have advised to limit the data for effective analysis when the use of documents is selected as a data collection method. Limiting the data allows the researcher to analyze the available data in-depth while systematically following the data analysis procedure and coding guidelines. Knowledge of the methodological assumptions, limitations and delimitations help establish the quality of the qualitative inquiry.

### 10. Providing ethical assurances

Several ethical issues arise in qualitative research. Shank [13] has provided four general ethical guidelines in qualitative research: (a) do not harm (for example, taking permission to observe), (b) be open (for example, observing people with their knowledge), (c) be honest (for example, using material with permission), and (d) be careful (for example, ensuring the results of the study can be traced to the data).

Silverman and Marvasti [7] have similarly mentioned four general principles to establish code of research ethics in qualitative inquiries: (a) voluntary rather than forced participation, (b) safety of research participants, (c) discussing potential benefits and risks of participation, and (d) obtaining informed consent. In the context of the qualitative research design using case study and data collection method based on archival documents, most of the above mentioned ethical issues did not arise as archival analysis was used and the selected EA framework documentation was publicly available.

### 11. Conclusions and observations

Following a consistent research design terminology and explicitly explaining each term before its first use is usually the foremost step in improving the quality of the research work. The discussions and confusions on terminologies in quantitative and qualitative approaches still exist [18, 19]. As the researchers are required to rationalize and document the choices in research design, the most obvious tendency is to use the research design that is well understood. Quantitative approach and survey methods remain popular choices.

The focus of the paper is to present the argument the selection of a research methodology should be driven by the research problem and the purpose of the

study. The paper provides a completed research problem and the purpose of study and demonstrates the scholarly reasoning for the overall research design. Providing proper reasoning for each choice in research design help improve the quality of research. Guidelines should be followed for developing problem statement, purpose statement and research questions. Different approaches to research inquiry, namely, quantitative, qualitative and mixed method, should not only be known and understood, but also their suitability criteria for the research problem should be clearly identified. What will be the knowledge claims? Which strategy of inquiry will be used? Which research method is best for the problem? All of these questions should be answered and justified. Questions surrounding participants and population size should be clearly articulated. Readers of research work look for answers to validity and reliability and whether the results are generalizable or not.

A qualitative case study should be able to provide proper explanations and justifications for all the concerns highlighted in the previous paragraph. The problem arises when qualitative case studies are analyzed using “quantitative lens.” Through the quantitative lens, the validity and reliability are demanded with different connotations. Questions about instrument, population size and generalization are raised.

### 12. References

- [1] Zikmund, W. G., *Business Research Methods*, Thomson Learning, Mason, OH, 2003.
- [2] Patton, M. Q., *Qualitative Research & Evaluative Methods (3rd ed.)*, Sage Publications, Thousand Oaks, CA, 2002.
- [3] Creswell, J. W., *Research Design: Qualitative, Quantitative, and Mixed Methods Approaches (2nd ed.)*, Sage Publications, Thousand Oaks, CA, 2003.
- [4] Anonymous, *FEA Consolidated Reference Model (document version 2.3)*, Office of Management and Budget, US, October 2007.
- [5] The Open Group Architecture Forum, *The Open Group Architecture Framework - TOGAF Version 9*, The Open Group, United States, 2009.
- [6] Gregor, S., Hart, D., and Martin, N., “Enterprise Architectures: Enablers of Business Strategy and IS/IT

Alignment in Government,"*Information Technology & People*, 20(2), Emerald, UK, 2007, pp. 96-120.

[7] Silverman, D., and Marvasti, A., *Doing Qualitative Research: A Comprehensive Guide*, Thousand Sage Publications, Oaks, CA, 2008.

[8] Trochim, W. M., *The Research Methods Knowledge Base (2nd ed.)*, Thomson Learning, Mason, OH, 2001.

[9] Yin, R. K., *Case Study Research: Design and Methods (4th ed.)*, Sage Publications, Thousand Oaks, CA, 2009.

[10] Smith, N. C., "The Case Study: A Useful Research Method for Information Management," *Journal of Information Technology*, 5(3), Palgrave Macmillan, UK, September 1990, pp. 123-133.

[11] Cepeda, G., and Martin, D., "A Review of Case Studies Publishing in Management Decision 2003-2004: Guides and Criteria for Achieving Quality in Qualitative Research," *Management Decision*, 43(5/6), Emerald, UK, 2005, pp. 851-876.

[12] Sage, T. A., *A Model of Factors Affecting Business and Information Technology Alignment Enabled by Enterprise Architecture: A Structural Equation Modeling Analysis (Doctoral Dissertation)*, ProQuest Dissertations & Theses, US, 2006.

[13] Shank, G. D., *Qualitative Research: A Personal Skills Approach*, Pearson Merrill Prentice Hall, Upper Saddle River, NJ, US, 2006.

[14] Stake, R. E., "Case studies," *Handbook of Qualitative Research (2nd ed., N. K. Denzin & Y. S. Lincoln - Eds.)*, Sage Publishing, Thousand Oaks, CA, US, 2000, pp. 435-454.

[15] Sessions, R., "A Comparison of the Top Four Enterprise-Architecture Methodologies," *MSDN Architecture Center*, Microsoft, US, May 2007.

[16] Golafshani, N. (2003, December). "Understanding Reliability and Validity in Qualitative Research," *The Qualitative Report*, 8(4), Nova Southeastern University, Florida, USA, December 2003, pp. 597-607.

[17] Flyvbjerg, B., "Five Misunderstandings about Case Study Research," *Qualitative Inquiry*, 12(2), Sage Publications, Thousand Oaks, CA, US, April 2006, pp. 219-245.

[18] Janice M. Morse, Lynda J. Dimitroff, Robin Harper, Amanda Koontz, Savita Kumra, Nancy Matthew-Maich, Paul Mihas, and Christina Murphey, "Considering the Qualitative-Quantitative Language Divide," *Qualitative Health Research*, 21(9), Sage Publications, Thousand Oaks, CA, US, September 2011, pp.1302-1303.

[19] Igor Hanzel, "Beyond Blumer and Symbolic Interactionism: The Qualitative-Quantitative Issue in Social Theory and Methodology," *Philosophy of the Social Sciences*, 41(3), September 2011, pp. 303-326.

# The Influence of Person-Organization Fit Job Satisfaction and supportive organizational culture on organizational commitment

Yu-Shan Chen, Yu-Hsien Lin

*Department of Business Administration, National Taipei University, Taiwan, Department of Business Administration, National Taipei University, Taiwan.*

[yushan@mail.ntpu.edu.tw](mailto:yushan@mail.ntpu.edu.tw), [s8993110@webmail.ntpu.edu.tw](mailto:s8993110@webmail.ntpu.edu.tw)

## Abstract

*The main purpose of this study is to explore the influences of person-organization fit (P-O fit), job satisfaction, and supportive organizational culture on organizational commitment to fill the research gap. The study applies questionnaire survey method to test the hypotheses by means of structural equation modeling (SEM). The overall fit measures of this study is as follows:  $\chi^2 = 320.82$ ,  $p < .05$ ,  $GFI = 0.86$ ,  $RMSEA = 0.099$ ,  $NFI = 0.89$ ,  $CFI = 0.92$ ,  $SRMR = 0.090$ ,  $NNFI = 0.90$ ,  $PNFI = 0.73$ ,  $CN = 87.46$ ,  $\chi^2/df = 3.27$ . This study finds out that P-O fit positively affects supportive organizational culture, job satisfaction, and organizational commitment. Besides, this study demonstrates that supportive organizational culture has positive effects on job satisfaction and organizational commitment. Furthermore, this research points out that supportive organizational culture and job satisfaction mediate the positive relationship between P-O fit and organizational commitment. If companies would like to enhance organizational commitment within them, they have to improve their P-O fit, supportive organizational culture, and job satisfaction.*

*Key words: person-organization fit (P-O fit), supportive organizational culture, job satisfaction, organizational commitment.*

## 1. Introduction

Organization, difficult and divergent, should be an aim of all scholars. The pursuit of knowledge, which involves not only history and literature, but also individual and group knowledge, can be important in research. Some things we value, not for themselves but for their side effects. The exact methods of organization knowledge vary, owing to there are so many different approaches. People are the most

important asset in organizations, organizations depend on people to act. Kristof (1996) pointed out, the person and the organization fit (P-O fit) affects employee behavior. Recently, management scholars have gradually come to value P-O fit. Recently, studies have directly or indirectly observed that person and organizational fit directly or indirectly influence organizational performance (Kolenko & Aldag, 1989). Some scholars believe that personal and organizational adaptation is an important factor in company selection of employees (Werbel & Johnson, 2001). To summarize, person and organizational fit strongly impact organizational performance and employee behavior.

Leaders of company or organization are very important in organizational operations, and the philosophy or values of organizational leaders influence the operation mode of companies or organizations. Schein (1996) defined the organization culture as follows: First, the members of the organization are fairly consistent way to solve internal and external problems, and will pass this way to the new members of the organization. Second, there will be a consistently solution, mainly from among the members of the authenticity of the transaction, time, space, human nature activities or human relations similar assumptions. Third, these assumptions should be thought as a matter of course for organization members, and is internalized to become unconscious for organization members or do not need to test the hypothesis.

Organization, difficult and divergent, is something that all scholars should aim for. The pursuit of knowledge, which involves not only history and literature, but also individual and group, can be important in the process of research. Some things we value, not for themselves but for what they bring about. Exact methods of organization knowledge vary, because of the existence of numerous different



approaches. People are the most important asset in organizations, without people, the organization can not act. Kristof (1996) pointed out, the person and the organization fit (P-O fit) affects the behavior of the employees. In recent years, P-O fit gradually valued by management scholars. Recently, studies have pointed out person and organizational fit influence organization performance directly or indirectly (Kolenko & Aldag, 1989). Some scholars believe that the company selected employees, personal and organizational adaptation is a very important factor (Werbel & Johnson, 2001). In sum, person and organizational fit, have a major impact on organization performance and behavior of employees.

Leaders of company or organization play a very important role in the operation process of organization, philosophy or values of the leader affect the operation mode of companies or organizations. Schein (1996) defined the organization culture as follows: First, the members of the organization are fairly consistent way to solve internal and external problems, and will pass this way to the new members of the organization. Secondly, there will be a consistently solution, mainly from among the members of the authenticity of the transaction, time, space, human nature activities or human relations similar assumptions. Third, these assumptions should be thought as a matter of course for organization members, and is internalized to become unconscious for organization members or do not need to test the hypothesis.

In organizational culture, Hofstede, Neuijen, Ohayv, and Sanders (1990) proposed the ten dimensions of organizational culture, including: member identity, group emphasis, people focus, unit integration, risk tolerance, reward criteria, conflict tolerance, means-end orientation, open-system focus and control. Hofstede *et al.* believe that organizational culture presents a system of values and practices, and practice including habits, heroes and symbols. Organizational culture has its positive and negative features, and Schein (1985) proposed that it has three functions: (1) organizational culture can solve the problem of the external environment adaptation. (2) organizational culture can solve organizational problems of internal integration. (3) organizational culture can reduce the anxiety of the individual. From the above, the positive functions of organizational culture are to organize its creation and maintenance, while its negative impact is to hinder reformation, collective escape, and prejudice development. To summarize, the organizational culture denotes the cultural connotation and value judgments to

organization, guides the interpretation of the information, and fixes deviant member behavior.

Ashkanasy *et al.* (2000) believes that when an individual analyzes organizational cultures, he or she should understand the organization's histories, find out about the founders and early leaders, be aware of the critical defining events in the organization's evolution and when this has been accomplished, one can indeed describe sets of shared assumptions that derive from common experiences of success and shared traumas. In summary, we call the set of assumptions as "the culture" at a given time. Supportive organizational cultures provide employees with access to opportunity to further important values and goals through work.

Job satisfaction plays an important role on organizational citizenship behavior. Hoppock (1935) proposed that job satisfaction is how employees satisfied with environment factors of physical and mental aspects. Employees might be interested in objectives of some of their work, may be dissatisfied by an orientation towards others. It is hypothesized that employees can balance their sense of satisfaction and dissatisfaction and achieve comprehensive satisfaction. Warr, Cook, and Wall (1979) pointed out that job satisfaction is employee satisfaction with internal and external characteristics of work. Researchers believe that when the definition of job performance includes behaviors such as organizational citizenship the relationship between satisfaction and performance will improve (Organ, 1988). Follow-up researches by Hwang and Chi (2005) reports that job satisfaction leads to employee and firm performance. Evidently, job satisfaction has some influence on organizational performance. Smith, Kendall, and Hulin (1969) measured satisfaction in terms of five aspects of a person's job: pay, promotion, supervision, the work itself, and co-workers, because job satisfaction is multidimensional and combines psychological, physiological and environmental circumstances. Warr *et al.* (1979) defined job satisfaction using extrinsic and intrinsic features of the job as well as overall job satisfaction. Employee job satisfaction is a subjective reaction under environmental circumstances. Currivan (2000) considered that there is a positive relationship between job satisfaction and organizational commitment. Igarria and Greenhaus (1992) confirmed that there is a positive relationship between job satisfaction and organizational commitment. In summary, this study suggests that job satisfaction depends on the gap between work expectations and the actual value of work, which significantly impacts organizational commitment. Therefore, the purpose of

this research is to understand the antecedents and consequences variables of job satisfaction.

The Organization Man was published and the concept of organizational commitment was first proposed by Whyte (1956). The concept of organizational commitment was first proposed by Becker (1960). As Becker said: "Commitments come into being when a person, by making a side-bet, links extraneous interests with a consistent line of activity." In the organization, the side-bet investment may refer to all the valuable things, such as welfare, energy, and possessed skills that can only be used in the specific organization. Becker (1960) said that increase commitment by getting people to make side-bets on which they gain more if the target commitment is completed. Employees must remain with the organization unilateral invested to increase in the organization of a psychological phenomenon. Katz (1964) proposed three activities crucial to the successful functioning of an organizational system. Employees must be hired and retained; work role performance must be accomplished dependably and employees must exceed their formal job requirements. Katz's (1964) third behavioral category is classified as extra role behavior. The term "organizational citizenship behaviors" was created to depict extra-role those behaviors previously described by Katz (1964). Katz (1964) said that organizational citizenship behavior is an important concept within the performance domain because an organization that evolves solely around task activities can be a fragile system.

Steers (1977) concluded that commitment is strongly related to personal characteristics, job characteristics and work experience. Also, commitment is related to desire and intent to remain for both groups, and is only moderately related to attendance and turnover for the scientist and engineer group. Farkas and Tetrick (1989) pointed out that job satisfaction is positively related to organizational commitment. Therefore, organizational commitment is important in researching organizational and human behavior. Organizational commitment not only is a focus of the social sciences, but also has attracted considerable interest from management scholars.

This study hopes through the study of P-O fit to understand the effect of supportive organizational culture and job satisfaction on organizational commitment on organizational commitment. This study predicts the impacts, supportive organizational culture, job satisfaction and organizational commitment, when applied in business practices.

## 2. Literature Review

### 2.1. Person-Organization fit

Pfeffer and Salancik (1978) defined organizations as being comprised of individuals who share some common purpose. Pfeffer and Salancik (1978) see the key to organizational survival as the ability to acquire and maintain resources, and see organizational survival as dependent on these finite resources. Pfeffer and Salancik (1978) proposed resource dependence theories and suggested that resources are valuable because they contain some innate quality. Organizations are the setting for exchanges of inducements and contributions occur, and resource dependence theory explores the categories of relationships inside organizations. Resource dependence theory holds that organizations interact with their environments and respond to available opportunities and constraints. Rynes and Gerhart (1990) suggested that (1) assessments of general employability differ from firm-specific assessments, (2) there is a firm-specific component to interviewers' evaluations of job applicants, and (3) interpersonal skills, goal orientation, and physical attractiveness contribute to assessments of fit. Rynes and Gerhart (1990) found that P-O fit is a separate construct from general employability, and that interviewers evaluate P-O fit according to their organizations, not just idiosyncratic biases and liking.

People and organizations are attracted to one another based on their similarities. Schneider's ASA framework proposes that both applicant job choice behavior and organizations hiring practices are the major antecedents of P-O fit. Empirical evidence supports this argument (Adkins, Russell, & Werbel, 1994; Cable & Judge, 1994; Judge & Bretz, 1992; Rynes & Gerhart, 1990; Tom, 1971).

Empirically evidence suggests that high P-O fit level has a positive effect on some results. PO adaptation is considered to be like job satisfaction and organizational commitment, work attitude ( such as Boxx, Odom , & Dunn, 1991; Bretz & Judge, 1994; Chatman, 1991; Downey, Hellriegel, & Slocum, 1975; Lauver & Kristof-Brown, 2001; O'Reilly, Chatman & Caldwell, 1991; Posner, Kouzes & Schmidt, 1985; Tziner, 1987; Vancouver & Schmitt, 1991; Westerman & Cyr, 2004).

P-O Fit has also been found to predict organizational citizenship behavior (O'Reilly & Chatman, 1986). Positive organizational-level occupational outcomes are associated with high levels of P-O Fit, also supporting the notion that P-O fit is a multidimensional construct.

Kristof's (1996) extensive review of the P-O fit literature identified four different operationalizations of P-O fit. The first operationalization of P-O fit centers on measuring similarity between individual and organizational values (Boxx *et al.*, 1991; Chatman, 1989, 1991; Judge & Bretz, 1992; Posner, 1992). The second operationalization of P-O fit is goal congruence with organizational leader or peers (Vancouver, Millsap, & Peters, 1994; Vancouver & Schmit, 1991). The third operationalization of P-O fit is the match between individual preferences or needs and organizational systems and structures (Bretz, Ash, & Dreher, 1989; Cable and Judge, 1994; Turban and Keon, 1993). The fourth operationalization of P-O fit is the match between the characteristics of individual personality and organizational climate - sometimes labeled organizational personality. (Bowen *et al.*, 1991; Burke & Deszca, 1982; Ivancevich & Matteson, 1984; Tom, 1971).

Obviously, there is a special focus on interaction between individual and organizational factors, and this is an important vision in modern research of organizations.

The seminal review on P-O fit literature by Kristof (1996) suggested at least three kinds of different dimensions of fit, namely: (1) supplementary fit, (2) needs-supplies fit, and (3) demands-abilities fit. Kristof (1996) identified several major dimensions of fit. The first dimension is the distinction between supplementary fit and complementary fit. Another dimension of fit is the distinction between needs-supplies and demands-abilities fit. In addition, the complementary fit can be divided into needs-supplies and demands-abilities fit.

Past fit research found that successful employees must fit both the job and the organization (Bowen, Ledford, & Nathan, 1991; Kristof-Brown, 2000). Excluding needs-supplies fit appears incomplete. Needs-supplies fit perceptions are judgments of congruence between employee needs and rewards. Cable and DeRue (2002) proposed three different types of fit: person-organization fit, needs-supplies fit, and demands-abilities fit. Perceptions of person-organization fit were the best predictors of four organizational outcome variables, including citizenship behaviors and turnover decisions. Cable and DeRue (2002) found that perceived needs-supplies fit was the best predictor of job satisfaction, career satisfaction, and occupational commitment. Cable and DeRue (2002) argued that four different general conceptualizations of fit exist based on congruence between individual needs and organizational reinforcement system and structures. Bretz and Judge

(1994) proposed the same perspective. In recent years, the relationship between P-O fit and job satisfaction is continuously verified. Related researches are flourishing and still in the ascendant, and the impact of organizational commitment on P-O fit and job satisfaction tested in this study.

Cable and DeRue (2002) proposed three types of fit and their impact on work attitude and behavior. This study defines P-O fit as the values fit, personal and job fit, coinciding with the definition used by Edwards (1991). We divided P-O fit into needs-supplies fit and demands-abilities fit.

Therefore, this study quoted the view of Kristof (1996), adopting both needs-supplies fit and demands-abilities fit. The dimensions are divided into supplementary and complementary fit factors.

## 2.2. Supportive Organizational Culture

The concept of organizational culture has become a new necessary component both from academics and practitioners since Pondy and Mitroff published their "Beyond Open System models of Organization" in 1979. The study of organizational culture has become an important issue. For example, Smircich (1983) has analyzed different conceptions of organizational culture in relation to the anthropological schools.

Wilkins and Ouchi (1983) called culture as "clan" and defined culture as "shared social knowledge". Wilkins and Ouchi (1983) illustrate culture as a general paradigm, and a perception of goal congruence. Culture provides a general paradigm that helps participants determine collective interest. As Wilkins and Ouchi (1983) note, goal congruence helps us understand the motivation of members to cooperate and work in the clan. While the growth progresses of an organization is changing the original traditional thinking pattern behavior way value concept and cognize pattern of human being. Value concept and faith become core concept of every organization during operation, and every organization is a product of how its members think and interact. Smircich (1983) claimed that organizational culture is a system of shared meaning. Smircich (1983) articulated that culture is a set of core values, beliefs and understandings that are shared by members of an organization. Members of an organization sense the particular culture of an organization. In this sense, collective behaviors are taught to new organizational members so as to create a cohesive culture.

Wallach (1983) pointed out that there are three types of organizational culture (a) bureaucratic, (b)

innovative, and (c) supportive to measure the organizational culture. Wallach (1983) pointed out that a supportive culture exhibits teamwork and a people-oriented, encouraging, trusting work environment.

Schein (1992) formally defined culture as “a pattern of shared basic assumptions that the group learned as it solved its problems of external adaptation and internal integration, that has worked well enough to be considered valid and, therefore, to be taught to new members as the correct way you perceive, think, and feel in relation to those problems.” For every individual shares set of assumptions and beliefs with organization members, should be viewed as organizational member. Therefore, culture of this group should be learned by every individual member of the group.

Wallach (1983) noted that organizational culture is the shared understanding of an organization's employees—how people do things around here. These beliefs, values, norms, and philosophies determine how things work.

Cameron and Freeman (1991) has classified organizational culture into four categories (a) clan culture, (b) adhocracy culture, (c) hierarchy culture, and (d) market culture to measure the organizational culture.

Quinn and McGrath (1985) have suggested four types of organizational culture (a) rational culture, (b) adhocracy culture, (c) developmental culture, (c) Consensual culture, and (d) hierarchical culture to measure the organizational culture.

Supportive organizational culture is a cognitive system that employees think and make decisions. Supportive organizational culture is a warm and inclusive place to work. Wallach (1983) noted that people are friendly, fair and helpful to each other. They are open, harmonious environments, almost like an extended family. A company has a highly supportive environment if it is trusting, safe, equitable, sociable, encourage, open, relationship-oriented and collaborative.

Supportive organizational culture is a harmonic, equitable, trusting, encourage and open environment. Supportive organizational culture is a supportive, caring and relationship-oriented organizational culture.

### 2.3. Job Satisfaction

Previous studies have indicated that job satisfaction is the antecedent variables of organizational commitment (Bagozzi, 1980; Bartol, 1979; Brown & Peterson, 1994; Mathieu & Hamel, 1989; Reichers, 1985). In recent years, Koslowsky,

Caspy, and Lazar (1991) pointed out that a high correlation between job satisfaction and organizational commitment, and other scholars reached the same conclusion (Knoop, 1995; Mathieu & Zajac, 1990; Shore & Martin, 1989).

Obviously, organizational commitment and job satisfaction variables affect organizational outcomes, such as intention to leave (Shore & Martin, 1989), turnover (Brown & Peterson, 1993; Mathieu & Zajac, 1990), absenteeism (Sagie, 1998) and work performance (Shore & Martin, 1989).

Hoppock (1935) proposed the construct of job satisfaction and conducted lots of work on the issue of job satisfaction. However, despite the fact that scholars interpret this construct in numerous ways the so-called job satisfaction can be roughly divided into two views, the global and the facets.

Job satisfaction is a global construct or as a constellation of different dimensions to which the employee reacts affectively (Kreitner & Kinichi, 1995). Wiess (1967) measured general satisfaction as the aggregate of employee perception of 12 intrinsic facets and six extrinsic rewards derived from their job plus the technical abilities of the employee supervisor and the humanistic relationship between the employee and their supervisor. Job attitudes based on the influences of frames of reference on evaluations of job outcomes were initially formulated by Smith *et al.* (1969). Frames of reference can be defined simply as the relative standards individuals use in evaluating their job outcomes. In addition, Porter and Lawler (1971) defined satisfaction as a discrepancy and defined it as the extent to which actual rewards meet or exceed perceived equitable rewards.

Since Hoppock (1935), job satisfaction has had various different forms. Some researchers prefer overall satisfaction scores, either through single items (Quinn, Graham, & McCullough, 1974) or aggregates of several items (Brayfield & Rothe, 1951). Researchers have long accepted Locke's (1969) classic definition of job satisfaction, which incorporates both cognitive (“an appraisal of one's job”) and affective (“emotional state”) elements. As an attitude, job satisfaction is summarized in the evaluative component and comprises of cognitive, affective, behavioral components.

Seven tools are used to measure job satisfaction. The first and most common tool used to measure job satisfaction was developed by Weiss, Dawis, England, and Lofquist (1967) and is called the Minnesota Satisfaction Questionnaire (MSQ). The scale is based on the Theory of Work Adjustment, which uses the correspondence between work personality and work

environment as the primary reason or explanation for observed work adjustment satisfaction. The scale includes two dimensions, namely intrinsic and extrinsic subscales. The former denotes the nature of job tasks themselves and reinforces factors that cause satisfaction, such as achievement, moral values and independence. The latter concerns aspects of work that have little to do with the job task or work itself, such as pay, supervision-human relations, supervision-technical, company policies and practices. General satisfaction refers to the combination of intrinsic and extrinsic satisfaction. The MSQ Scale assessment work can be evaluated for the realization of the extent of demand for basic needs, there are two forms of the scale. The long-form MSQ consists of 100 items that make up 20 facets of the job. The short-form MSQ comprises the 20 facets listed above, with each facet represented by just one satisfaction item.

The second tool is the "job description indicators" (JDI), which were developed by Smith *et al.* (1969). Job Descriptive Index is a scale used to measure five major factors associated with job satisfaction: the work itself, pay, opportunities for promotion, and supervision. These experiences were examined through a 5-dimensional, 72-item instrument to assess five facets of job satisfaction. JDI is currently the most widely used scale for assessing job satisfaction. An 'Abridged' 25-item version Short Scale was developed, and each facet in the aJDI comprises five items. An additional scale, Job in General (JIG), evaluates overall job satisfaction. The short form of the JIG scale consists of eight items.

The third tool is the "job satisfaction indicators" (Job Satisfaction Index, JSI) scale, developed by Brayfield and Rothe (1951). Job satisfaction is the level of affinity one feels for a job and company. To capture this attribute, Brayfield and Rothe (1951) created the Job Satisfaction Index, a scale that measures overall job satisfaction based on 18 questions was included.

The fourth tool is "Michigan Organization Assessment Questionnaire, MOAQ" (Cammann, Fichman, Jenkins, & Klesh, 1979) which defines job satisfaction as a positive state of emotion regarding one's job. A three-item scale from the Michigan Organizational Assessment Questionnaire was employed to measure overall or global job satisfaction (Cammann *et al.*, 1979).

Spector's Job Satisfaction Survey (JSS) defines nine facets of job satisfaction. JSS scale is a scale used to measure nine major factors associated with job satisfaction: salary, promotion, supervision, fringe benefits, contingent rewards, operating procedures, co-workers, work, communication, and supervision.

Overall job satisfaction was measured by all 36 questions.

The sixth tool is Job Diagnostic Survey (JDS), adapted from Hackman and Oldham (1975). JDS measures employee perceptions of five core job dimensions: Skill Variety, Task identity, Task significance, Autonomy, and Feedback. In addition, measures are obtained for two additional dimensions which have been found helpful in understanding jobs and employee reactions to them, namely: dealing with people and feedback from agents. The JDS scale assessment of the work can be provided to the extent of the core characteristics of employees. This scale is based on three questions, namely (a) the long-form JDS scale: the first part of which comprises seven items, the second part 14 items, the third part 15 items, the fourth parts 14 items, the fifth part 10 items, the sixth part 11 items, and the seventh part 12 items; (b) A brief version of the JDS: the first part of which consisted of seven items, the second part 14 items, the third part seven items, the fourth parts 14 items, and the fifth part 11 items, and (c) One organization is using the instruments for rating job characteristics with special thoroughness. The Job Rating Form was collected from respondents who were in supervisory positions in the relevant job, and for outside observers. The first part of the scale included seven items, and the second part included 14 items.

The seventh tool is the Job In General Scale (JIG).

Ironson, Smith, Brannick, Gibson, and Paul (1989) developed the JIG to accompany the full-length JDI scale. JIG was designed to assess overall job satisfaction rather than facets. The full-length scale was originally developed and validated by Ironson *et al.* (1989). The abridged version of the JIG was designed to offer the practical advantages of a very brief instrument (Russell, Spitzmuller, Lin, Stanton, Smith, & Ironson, 2004).

The job satisfaction in this study is defined as the perceived characteristics of the job in relation to the frames of reference of an individual. This study examines the extent to which variations in perceptions of job characteristics reflect individual frames of reference and general job satisfaction. This study uses the JSS scale to measure job satisfaction.

## 2.4. Organizational Commitment

The perspective of organizational commitment originates from Becker (1960), who said that commitment is applied to reach on organizational behavior. Katz (1964) identified three basic types of citizenship behavior and distinguished between

dependable role performance that is in-role behavior and what he described as spontaneous behavior that is extra-role behavior. Katz (1964) proposed that efficient operations require an organization to possess the following three basic conditions pertaining to employees: (1) participating and staying in the organization, (2) acting according to the behavioral principles regulated by the organization; and the most important condition, (3) automatic devotion to the organization. Smith, Organ, and Near (1983) later conceptualized these conceptions as “organizational citizenship behavior”.

Porter, Steer, and Boulian (1974) proposed that there are three dimensions in organizational commitment: (1) identification commitment namely, strength of employee belief in and acceptance of an organizational goals and values, (2) involvement commitment (that is, level of employee dedication to an organization), and (3) commitment to stay (that is, level of employee desire to stay with an organization). The concept of organizational commitment has been examined extensively in this study.

The Organizational Commitment Questionnaire (OCQ) was developed by Mowday, Steers, and Porter (1979) for measuring employee commitment to their organizations, and has good reliability and validity. This study adopts the scale of OCQ scale of Mowday *et al.* (1979) to measure employee commitment to their organization. Meyer and Allen (1991) proposed a three-factor model of organizational commitment and conducted empirical research based on the proposed model. They used this scale to evaluate three organizational factors (affective commitment, continuance commitment and normative commitment) with an 18-item scale. Meyer and Allen (1991) defined organizational commitment as, “the view that commitment is a psychological state that (a) characterizes the employee’s relationship with an organization and (b) has implications for the decision to continue membership in an organization.”

Employees who are affectively committed to an organization will probably carry on working for it because they want to.

Continuance commitment refers to awareness of the costs associated with leaving an organization. Because of the individual’s awareness or consideration of expenses and threats linked to leaving the organization, this state of mind is considered calculative.

Normative commitment can be explained as a sense of responsibility to continue working for a specific organization. Normative commitment refers to an obligation to continue employment. Employees with

high level of normative commitment feel they should remain with the organization.

Meyer and Allen (1991) proposed a three-factor model of organizational commitment and organizational commitment scale to measure three factors of the organizational commitments. Prior research on the antecedents of organizational commitment (Steers, 1977) found less concern about the job satisfaction and supportive organizational culture as the antecedents. Therefore this study uses the two variables job satisfaction and supportive organizational culture to explore the antecedents of organizational commitment.

### 3. Hypothesis

While historically many job characteristics theories can predict people’s attitudes to job characteristics and career choice, they cannot predict the fit between individuals and specific organizations. Therefore, scholars beginning to pay attention to the importance of the organization, and on the relationship between individuals and organizations. Schneider (1987) formulated and examined the attraction-selection-attrition (ASA) model. The ASA model explores the relationships between person-organization fit. P-O fit including goal congruence (e.g., Vancouver & Schmitt, 1991), value congruence (e.g., Boxx *et al.*, 1991; Harris & Mossholder, 1996; Judge & Cable, 1997; Meglino, Ravlin, & Adkins, 1989; O’Reilly, *et al.*, 1991), needs-structure fit (e.g., Bretz, Ash, & Dreher, 1989), and personality-climate fit (e.g., Christiansen, Villanova, & Mikulay, 1997), of which elements, value congruence is the most widely used model.

Interactive psychology depicted, they believe that the characteristics of the individual and situation will combine in certain circumstances so as to affect a response from a specific individual. Widespread impacts on individual behavior and attitudes, may hold throughout an organization, especially its core values (Chatman, 1989). Person-organization fit referred to judgments of congruence between the personal values of an employee and the culture of an organization, whereas person-job fit perceptions referred to judgments of congruence between employee values, behaviors and attitudes and organizational culture, strategic needs, organizational norms and organizational values (e.g., Cable & Judge, 1996; Kristof-Brown, 2000). Person-organization fit is a meaningful way to assess the interaction between people and situations, because the values are basic, long-lasting, and directly comparable (Chatman, 1989).

Organizational culture can also be interpreted as a set of personality traits, beliefs, awareness, and values. Organizational culture is identified by the members of the organization, and taught to new members, and is an unwritten rule within the organization. Louis (1980, 1990) proposed that interaction with members facilitates sense making, situational identification, and acculturation among recruits. People who perceive good fit with their organization are likely to commit themselves to that organization.

P-O fit affects the intention of job seekers to apply job based on the ASA model. P-O fit exists in the organization of organizational values among its members, and follows the values of individual employees and impacts changes in tenure (Chatman, 1989). The employees of the organization of recruitment will respond practices, organization employees have the same values, and dismiss who fail to fit, organizations can build strong and stable attachment between members. Different personalities prefer different organizational cultures, and different personality traits have different choices. Adaptation between organizational attributes and value is the recent focus of research (Ambrose, Arnaud, & Schminke, 2008; Carless, 2005). Scholars such as Kristof (1996) have defined the compatibility between people and organizations as being based on sharing similar basic characteristics, particularly values, and sharing at least one entity. Kristof (1996) defined P-O fit as, "the compatibility between people and organizations that occurs when: (a) at least one entity provides what the other needs, or (b) they share similar fundamental characteristics, or (c) both." The main ideas of this construct are the congruence we observe between individual and organizational beliefs.

Schneider (1987) pointed out that the fit between people and organizations affects job seekers. When organizations and individuals agree on values, it is easy for those individuals to work in the organization, and easy for the organization to pay those individuals for their work. Cable and Judge (1994) pointed out that the perception of P-O fit was the predictor of job choice intentions, and was based on the ASA model of Schneider (1987). This study explores the relationship between P-O fit and supportive organizational culture, so as to fill the research gap. **We hypothesize that person-organization fit positively influences supportive organizational culture. (H1)**

Selznick (1957), who called on leaders to infuse organizations with value by communicating to employees the benefits and virtues of the organization and its mission in a way that made employment a source of satisfaction. Selznick (1957) wrote that

organizations become mature and 'institutionalized' only when leaders infuse them with values. Values guide day-to-day activities in organizations. Personal values, beliefs, attitudes, and the work itself may affect working practice. Individuals commit to organizations when leaders appeal to them in terms of their values, needs and customs. Glasser (1965) believes that humans are hardwired with five genetically encoded needs that are present at birth: survival, love and belonging, power and achievement, freedom or independence, and fun. These needs drive behavior, which is purposeful and chosen to meet our needs. Therefore, we believe that employees with higher P-O fit are less likely to commit unfriendly interpersonal interactions, less likely to complain about the organization, and thus have higher job satisfaction. Cable and DeRue (2002) argued that employees develop perceptions of three different types of fit: person-organization fit, needs-supplies fit, and demands-abilities fit. Their study concluded that perceptions of needs-supplies fit were related to job-and career-focused outcomes.

Besides the impact of person-organization fit at a specific point in time, changes in person-organization fit may affect attitudes and behaviors over time. Employees who fail to fit within the environment generally experience anxiety and incompetence. When employees sense that an organization really inspires the very best in terms of job performance, they tend to experience more positive and less negative affect, and are likely to choose to stay in that environment (Pervin & Rubin, 1967; Emmons, Diener, & Larsen, 1986). Accordingly, higher P-O fit may lead to greater job satisfaction, and a highly likelihood of staying with their organization. Judge, Kristof-Brown, and Darnold (2005) pointed out that person-organization fit is related to job satisfaction. Verquer *et al.*'s (2003) study also reached the same conclusion. **We hypothesize that person-organization fit positively influences job satisfaction (H2).**

Organizational commitment is considered a better predictor of employee behavior than other attitudinal measures such as job satisfaction (Vroom, 1964; Steers & Porter 1983). Meyer and Allen (1991) considered commitment organization to have three components: affective commitment, continuance commitment and normative commitment. Steers (1977) believed that organizational commitment leads to several specific behavioral outcomes: (1) highly committed employees should have a strong desire and intent to remain with the organization; (2) employees who are strongly committed to the goals of an organization and have positive attitudes towards the organization should be



more likely to have a strong desire to work toward goal attainment; (3) commitment was related to performance that committed employees would expend greater effort on the job.

Also, Mowday, Porter, and Steers (1982) considered that the antecedents of organizational commitment can be classified into four categories: personal characteristics, role-related characteristics, structural characteristics, and work experiences. Mowday *et al.* (1982) identified four consequences variables as the outcomes of organizational commitment: job performance, absenteeism, tardiness, and turnover. Organizational commitment is defined in terms of the strength of individual identification with and involvement in a particular organization (Porter *et al.*, 1974; Knoke & Wright-Isak 1982; Mowday *et al.*, 1982). Morris and Sherman (1981) concluded that high levels social interaction between leader and subordinates have been equated with higher organizational commitment. Besides the four antecedents outlined by Mowday *et al.* (1982), job satisfaction is also considered an antecedent variable of organizational commitment (Meyer & Allen, 1997; Lok & Crawford, 2001; Hulpia, Devos, & Rosseel, 2009).

Employees will only work in exchange for economic benefits. We take the benefits and subtract the costs to determine the value of a relationship. Organizational commitment becomes the reason employees exert greater effort for limited financial reward.

Kristof (1996) pointed out that P-O fit is important and has practical applications in rehabilitation because it can be used to predict movement across organizations, as well as eventual turnover. Employees with a high degree of P-O fit are more likely to be positively related to multiple organizational outcomes, including enhanced organizational commitment, increased productivity, and reduced turnover (Van Vianen, 2000). Person-organization fit has also been shown in a meta-analysis to be an antecedent of organizational commitment (Verquer *et al.*, 2003). Gill and Finegan (2000) have the same result. This study thus suggests that the congruence between individual and organizational value obtains more positive responses in organizations with values similar to those of the relevant individual. Employees with higher value congruence and compatibility will make a stronger commitment to an organization. **Therefore, we hypothesize that person-organizational fit positively influences on organizational commitment (H3).**

Based on Blau's (1964) social exchange theory, all human relationships are formed by the use of a

subjective cost-benefit analysis and the comparison of alternatives. The Social Exchange perspective argues that people calculate the overall worth of a particular relationship by subtracting its costs from the rewards it provides. We apply the idea and focus on the psychological concepts within the theory. We believe that the more often a particular action of a person is rewarded, the more likely the person is to perform that action. Supportive organizational cultures emphasize teamwork, employee participation and consensus (Cameron & Quinn, 2005). Supportive organizational culture create trusted, vibrant and fun environments that value individual employee contribution and also offers its members comfortability resulting from relationships. These types of organizational culture place high value on treating employees like extended family, fostering supportiveness and cohesion and encouraging teamwork and participation (Richard *et al.*, 2009). In supportive organizations, employees are engaged, committed and productive. Leaders act as facilitators, mentors, or parent figures helping to create a family-like atmosphere where employee contributions are recognized and appreciated (Kwantes & Boglarsky, 2007).

Social exchange theory suggests that social relationship involve the exchange of valued commodities between people. Cropanzano, Prehar, and Chen (2002) pointed out that the social exchange theory as a possible explanation for justice and fairness in organizations. Therefore, organizations provide an environment where employee's interests are supported and employees treated with fairness, employees will be more satisfied with their organization. These commodities include money, advice, political opportunities, trust, social support, and even positive feelings (e.g., Lawler & Yoon, 1998). Supportive organizational culture provides close, positive and supportive relationships among employees, which are an important source of recognition, esteem and support (Dutton & Heaphy, 2003). A supportive organizational culture has been associated with a variety of benefits for both employees and employers, including learn quickly from all members of the team and embrace new challenges every day. Satisfaction is a result of an individual's perception and evaluation of their job. Supportive organizational culture foster connectedness, supportive, and caring cultures that employees may feel pleased to work. There are several empirical investigation examines the impact of supportive organizational culture on job satisfaction. Lok and Crawford (2004) examined the direct link between organizational culture types and job satisfaction, and pointed out that supportive cultures had positive effect

on job satisfaction. Jiang and Klein (2000) argue that supportive culture of the organization increases the satisfaction level of the employees. We believed that supportive organizational culture may raise the level of job satisfaction of employees. Each employee most likely has some need to be fulfilled, such as meaningfulness, identity, and belongingness.

When employees experience a sense of community at work, it often helps to transform organization goals and values into personally endorsed goals and values (Gagné & Deci, 2005). Supportive organizational cultures allow using processes that are right for the organization, every individual can develop interpersonal relationships with organizational members. Therefore, organization goals and values as well as their personal needs are addressed and enhanced. Supportive organizational cultures provide employees the opportunity to complete a project by teamwork and participate. Gilbert and Sneed (1992) investigate nine hospitals in eastern Canada and nine hospitals in East Tennessee. Gilbert and Sneed (1992) pointed out that supportive organizational culture was positively related to work-related outcomes, including job satisfaction and organizational commitment.

Silverthorne (2004) found that supportive organizational culture had a significant positive effect on job satisfaction. This study try to find out whether there is work-related outcomes for supportive organizational culture such as job satisfaction. **Therefore, this study makes the following hypothesis that supportive organizational culture positively influences job satisfaction (H4).**

Research has shown that organizational cultures that promote fairness and trust engender social exchange relationships that embody a source of meaningfulness for employees (Cropanzano *et al.*, 2002). Wallach (1983) has suggested that individual job performance and favorable job outcomes, including job satisfaction, propensity to remain with the organization, and job involvement, depend upon the match between an individual's characteristics and the organization's culture.

Odom, Boxx, and Dunn (1990) found that employee attitudes and behaviors are enhanced by an organizational culture that exhibits innovative characteristics. Additionally, they found that employees who work in a supportive environment are more satisfied and have a greater degree of organizational commitment.

Gilbert and Sneed (1992) pointed out that supportive organizational culture was positively related to organizational commitment. According to Gilbert and Sneed's (1992) study, we believe that supportive

organizational culture has a positive effect on organizational commitment. **Therefore, this study suggests that supportive organizational culture has a positive influence on organizational commitment (H5).**

Organizational commitment is a connection between employees and their organization. Meyer and Allen (1997) stated that employees with a good relationship with their immediate work group have higher commitment. Lok and Crawford (2001) also found a strong positive relationship between job satisfaction and organizational commitment. Currvan (2000) pointed out a positive relationship between job satisfaction and organizational commitment. Hulpia *et al.* (2009) posited that job satisfaction significantly and directly effects on organizational commitment, and suggested increasing organizational commitment and job satisfaction to meet group goals. As Meyer and Allen (1997) pointed out, affective organizational commitment is defined as the emotional attachment, identification, and involvement of an employee with its organization and its goals. Higher job satisfaction, especially the emotional attachment and fringe benefits, enables employees to develop their identity and involvement with their organization. **Thus, we believe that employee job satisfaction positively influences organizational commitment (H6).**

This research investigates whether the various characteristics of the employees have competitive advantages for the enterprise by modeling person-organization fit as an antecedent, and supportive organizational culture and job satisfaction as intervening variables. We then examine whether relationships between several variables.

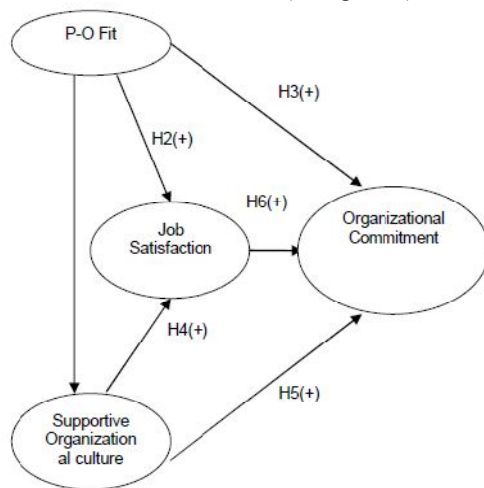
We are encouraged by the psychology and organizational studies literature. These examples teach us how to focus on human behavior and improve organizational performance. Also, positive ideas can ensure we do our job correctly as we work through a well-established system and focus on effective leadership. Person-organization fit, with supplementary fit and complementary fit factors, lead these emotional disturbances to affect cognitive abilities, enhance performance, and accelerate progress, and lead to individual identifying with the organizations where they work. Successful management, with action and psychology response, enables irreplaceable connection and so provides subtle interchanges of soul between members.

#### 4. Methodology and measurement

This study take questionnaires of “A Study of P-O fit, job satisfaction and organizational commitment.” as the instrument, questionnaires including “A Study of P-O fit, job satisfaction and organizational commitment.” and demographics.

It was first pre-tested among a group of experts and scholars. The respondents of this test were asked to provide comments on the relevance and wording. The questionnaires were basically a pretest-post test design. After receiving 20 questionnaires, some of the questionnaire items were dropped. Further, the questionnaire layout was modified, and mailed randomly to the sample selected from *2012 Yellow Book of Taiwan*. The respondents were asked to return the completed questionnaires within 2 weeks. 329 questionnaires from North, Central, South, and East Taiwan were completed. There were 232 valid questionnaires while 97 were invalid, and the effective response rate was 70.52%.

SEM was used to assess the hypotheses, and the research framework shown here (in Figure 1) below.



#### 5.1. Measurement model estimates

To assure content validity, this study employed two pretests for the questionnaire revisions. First, we evaluated with a pretest questionnaire in interviews with 8 part-time MBA students who had a minimum of three years of business experience. We asked for clarification, if there is something in the wording of the question that does not make sense to them or is ambiguous. Additionally, we evaluated with a pretest questionnaire with 20 full-time employees who had a minimum of three years of business experience.

Sample Question presented using a five-point Likert Scale from 1 to 5” rating from “strongly disagree” to “strongly agree.”

P-O fit. This study quoted the view of Kristof (1996), adopting both needs-supplies fit and demands-abilities fit. The measurement of the P-O fit includes four items: (1) There is a good fit between what my job offers me and what I am looking for in a job; (2) The match is very good between the demands of my job and my personal skills; (3) My abilities and training are a good fit with the requirements of my job; and (4) My personal abilities and education provide a good match with the demands that my job places on me.

Supportive organizational culture. This study adopted Exploratory Factor Analysis (EFA) to extract the factors. This study adopted EFA to obtain the new factor loadings after deletion of those 8 items in supportive organizational culture subscale and 4 items in organizational commitment subscale. EFA results suggested 4 items remained in supportive organizational culture and 4 items remained in organizational commitment subscale. The measurement of the supportive organizational culture includes four items: (1) describe my organization trusting; (2) describe my organization safe; (3) describe my organization encouraging; and (4) describe my organization sociable.

Job satisfaction. Job Satisfaction Survey was developed by Spector (1985) and contains 36 items based on nine job facets. Spector’s Job Satisfaction Survey (JSS) which defines nine facets of job satisfaction. This study use JSS scale to measure main factors associated with job satisfaction. The measurement of the job satisfaction includes four items: (1) I feel I am being paid a fair amount for the work I do; (2) I like doing the things I do at work; (3) I feel a sense of pride in doing my job; and (4) My job is enjoyable.

Organizational commitment. This study adopts the scale of OCQ scale of Mowday *et al.* (1979) to measure employee commitment to their organization. The measurement of the organizational commitment includes four items: (1) I talk up this organizational to my friends as a great organization to work for; (2) I would accept almost any type of job assignment in order to keep working for this organization; (3) I m proud to tell others that I am part of this organization; and (4) There’s too much to be gained by sticking with this organization definitely.

#### 5. Results

Using confirmatory factor analysis to verify the research framework and hypotheses, we applied Lisrel 8.70 to obtain the results. SEM was used to assess the measurement and the structural models. The analysis of the squared multiple correlations demonstrated that the majority of items in this study met the conventionally used acceptance threshold of 0.30 (Shea, 1997).

### 5.1. Measurement model estimates

Descriptive statistics are used to describe the basic features of the data in the study. For pilot test (N=210), we conducted Exploratory Factor Analysis (EFA). This study adopted EFA to extract factors of each construct. The major latent factors extracted explained 61.831% of the variance in supportive organizational culture subscale. The major latent factors extracted explained 61.939% of the variance in organizational commitment subscale. This study adopted EFA to obtain the new factor loadings after deletion of those 8 items in supportive organizational culture subscale and 4 items in organizational commitment subscale. EFA results suggested 4 items remained in supportive organizational culture and 4 items remained in organizational commitment. The means, standard deviations and the correlation matrix between all the variables included in the model are presented in Table 1. Table 1, there are positive correlations among person-organization fit, supportive organizational culture, job satisfaction and organizational commitment. The results of the factor analyses reported in Table 2. Each construct in the study can be classified deliberately into only one factor. We developed items and assessed the factor structure based on previous studies. To assure content validity, this study employed two pretests for the questionnaire revisions. Questionnaires sent and returned by mail. To have confidence in a measure such as this, we need to test its reliability. First, we measure the reliability by examine the loadings of each constructs' individual items. Table 3 displays the factor loadings of all items on each construct. Second, we compute the Cronbach's  $\alpha$  to estimate the reliability. The Cronbach's  $\alpha$  coefficient of "P-O fit" is 0.840; that of "SOC" is 0.839; that of "JS" is 0.834; and that of "OC" is 0.915. Because the Cronbach's  $\alpha$  coefficients of all four constructs are more than 0.7, the measurement of this study is acceptable in reliability.

Table 1 Mean, standard deviation and correlation coefficient

	Mean	SD	A	B	C	D
PO	3.607	0.705				
SOC	3.654	0.745	.521**			
JS	3.598	0.718	.581**	.575**		
OC	3.767	0.793	.523**	.692**	.651**	

\* $p < .05$

Table 2 Factor analysis results

Constructs	Number of Items	Number of Factors	Accumulated percentage of explained variance
PO	4	1	68.183
SOC	4	1	67.494
JS	4	1	67.484
OC	4	1	79.766

Using confirmatory factor analysis, we analyzed measure validity with four constructs. There are two measurements to confirm the validity of the constructs. First, the "average variance extracted" measures the amount of variance that is captured by the construct in relation to the amount of variance due to measurement error, and this study applied average variance extracted (AVE) to assess the discriminative validity of the measurement (Fornell & Larcker, 1981). In order to meet the requirement of the discriminative validity, the square root of every construct's AVE must be greater than the correlations between the construct and other constructs in the model. The results show that our measurement approach exhibits desirable psychometric properties in Table 3. For example, the square roots of the AVEs for the two constructs, PO and SOC, are 0.812 and 0.800 in Table 3 which are more than the correlation between them, 0.521. Second, average variance extracted (AVE) should be higher than 0.5 and construct reliability should be higher than 0.7 for all constructs of a measurement model. The factor loadings, AVE and construct reliability can be seen in Table 3. As shown in Table 3, the AVEs of the four constructs are 0.66, 0.80, 0.65, and 0.82, respectively, which are all greater than 0.5. In this case, the convergent validity of the construct is acceptable. The validity of measurement model accessed through convergent and discriminate validity. The results demonstrate adequate reliability and validity in this study.

**Table 3 The items' factor loadings and the constructs' Cronbach's  $\alpha$  coefficients and AVEs**

Constructs	Item	Factor Loading	S M C	Cronbach's $\alpha$	AV E	The square roots of AVE
PO	PO1	.69	.47	.840	.66	0.812
	PO2	.89	.79			
	PO3	.89	.80			
	PO4	.75	.56			
SOC	SOC1	.61	.37	.839	.64	0.800
	SOC2	.87	.75			
	SOC3	.86	.74			
	SOC4	.83	.69			
JS	JS1	.57	.33	.834	.65	0.806
	JS2	.88	.77			
	JS3	.90	.81			
	JS4	.83	.68			
OC	OC1	.90	.81	.915	.82	0.906
	OC2	.91	.83			
	OC3	.94	.89			
	OC4	.86	.73			

\* $p < .05$

## 5.2 The results of the structural model

More specifically, we obtain the overall fit measures of the SEM in this study, that the fit of the model is very good (GFI = 0.86, RMSEA = 0.099, NFI = 0.89, CFI = 0.92). Hair *et al.* (1998) suggested that  $NFI > 0.8$  means satisfactory fit. It is recommended that  $\chi^2/df$  should not exceed 3 (Bentler and Bonett, 1989) while GFI should be greater than the

recommended value of 0.8 (Seyal, Rahman, & Rahim, 2002). AGFI should be greater than the recommended value of 0.8 (Seyal, Rahman, & Rahim, 2002). RMSEA smaller than 0.1 is desirable, and less than 0.08 is preferable (Klein, 1998). Table 4 shows the results of the structural model in this study. Effects of Factors in this model are truly acceptable and shown in Table 5.

**Table 4 Measures of overall model fit**

	Measurement model estimates	Results
	$\chi^2$ Sig	No, 320.82
	SRMR < .08	No, .090
Absolute Fit Measures	RMSEA < .1	Yes, .099
	GFI > .85	Yes, .86

Incremental Fit Measures	AGFI>.80	Yes, .81
	NFI>.80	Yes, .89
	NNFI>.90	Yes, .90
	CFI>.90	Yes, .92
	RFI>.90	No, .06
	IFI>.90	Yes, .92
Parsimonious Fit Measures	PNFI>.50	Yes, .73
	PGFI>.50	Yes, .61
	$\chi^2/df < 5$	Yes, 3.27
	CN >200	No, 87.46

Table 5 Effects of factors from structural equation modeling example

Path	Coefficients	
	Effect	t-Value
PO → SOC		
Direct Effect	0.55	6.84*
Indirect Effect	--	--
Total Effect	0.55	6.84*
PO → JS		
Direct Effect	0.43	5.42*
Indirect Effect	0.21	4.41*
Total Effect	0.64	7.56*
PO → OC		
Direct Effect	0.07	1.15
Indirect Effect	0.51	7.65*
Total Effect	0.58	8.66*

SOC → JS			
	Direct Effect	0.38	4.75*
	Indirect Effect	--	--
	Total Effect:	0.38	4.75*
SOC → OC			
	Direct Effect	0.56	7.31*
	Indirect Effect	0.12	3.67
	Total Effect:	0.68	8.40*
JS → OC			
	Direct Effect	0.32	4.42*
	Indirect Effect	--	--
	Total Effect:	0.32	4.42*



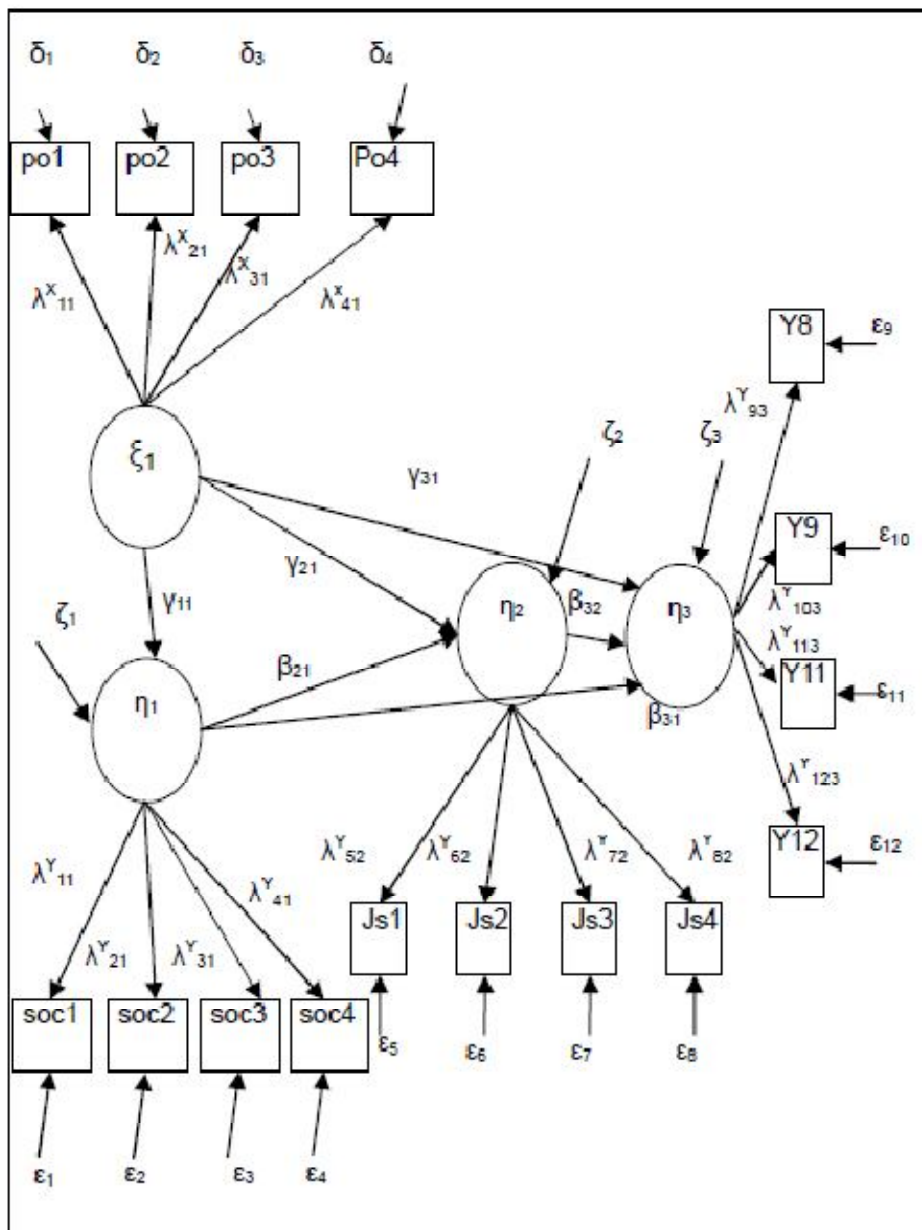


Figure 2 The results of the model

Figure 2 show the model in this study. All six paths estimated are significant. By using path analysis, the P-O fit positively affects supportive organizational culture, job satisfaction and organizational commitment. Supportive organizational culture positively affects job satisfaction and organizational commitment. Additionally, this study also verified supportive organizational culture and job satisfaction had partial mediation effects on the positive relationship between P-O fit and organizational commitment. Finally, H1, H2, H3, H4, H5 and H6 are all supported in this study.

## 6. Conclusion

Organizational theory has traditionally focused on those process and activities whose results are organizational citizenship behaviors. Many managerial questions arise as organizational cultures grow and decline, many managerial questions will arise. This study, which looks carefully at antecedents of job satisfaction and organizational commitment, thus focuses on an increasingly important issue. By recognizing the fundamental role of P-O Fit, supportive organizational culture, job satisfaction and organizational commitment and learning how to manage these factors competently, all organizations can develop a strong base on which to better develop organizational commitment.

Organizational commitment is an important factor in organization culture. Organizations must have a grand vision and adopt various processes as desired to improve job satisfaction and organizational commitment. This raises the question of how those studying organizations should approach the problem of understanding the influence of organizational commitment on organizational culture. Perhaps the best way is to understand the contribution of factors to organizational outcomes, and the marvelous implications of these factors for the future direction of organizations. From the customer perspective employees represent the whole business. Employee-centric organizational culture is what makes the organizational field so intellectually attractive and provides potential for further inquiry.

To summarize, the three most important and general implications are as follows: First, this study finds out that P-O fit positively affects supportive organizational culture, job satisfaction, and organizational commitment. Second, this study demonstrates that supportive organizational culture positively influences job satisfaction and organizational commitment. Third, this research points out that

supportive organizational culture and job satisfaction mediate the positive relationship between P-O fit and organizational commitment.

Since this study uses cross-sectional data it cannot measure many different things at different times. Future study should examine those constructs from a multilevel investigation or through longitudinal data. We discover that the nature of organization, the antecedent and consequent variables of job satisfaction and organizational commitment in the P-O fit model, and the impact on organizational commitment of antecedents all suggest that a useful way for enhancing organizational commitment will soon be on the horizon.

## References

- [1] Adkins, C. L., Russell, C. J., & Werbel, J. D. (1994). Judgments of fit in the selection process: The role of work value congruence. *Personnel Psychology*, 47, 605-623.
- [2] Ahmad, K. Z., & Veerapandian, K. A. (2012). The Mediating Effect of Person-Environment Fit on the Relationship between Organisational Culture and Job Satisfaction. *International Journal of Psychological Studies*, 4(1), 103-121.
- [3] Ambrose, M. L., Arnaud, A., & Schminke, M. (2008). Individual moral development and ethical climate: The influence of Person-Organization fit on job attitudes. *Journal of Business Ethics*, 77, 323-334.
- [4] Ashkanasy, N. M., Broadfoot, L. E., & Falkus, S. (2000). Questionnaire measures of organizational culture. In N. M. Ashkanasy, C. P. M. Wilderom, & M. F. Peterson (Eds.) *Handbook of organizational culture and climate* (pp. 131-147). Thousand Oaks, CA: Sage Publications.
- [5] Bagozzi, R. P. (1980). Performance and satisfaction in an industrial sales force: An examination of their antecedents and simultaneity. *Journal of Marketing*, 44, 65-77.
- [6] Bartol, K. M. (1979). Professionalism as a predictor of organizational commitment, role stress, and turnover: A multidimensional approach. *Academy of Management Journal*, 22, 815-821.
- [7] Becker, H. S. (1960). Notes on the concept of commitment. *The American Journal of Sociology*, 66, 32-40.

- [8] Blau, P. M. (1964). *Exchange and Power in Social Life*. New York: John Wiley & Sons.
- [9] Bowen, D. E., Ledford, G. E., & Nathan, B. R. (1991). Hiring for the organization, not the job. *Academy of Management Executive*, 5(4), 35-51.
- [10] Boxx, W. R., Odom, R. Y., & Dunn, M. G. (1991). Organizational values and value congruency and their impact on satisfaction, commitment, and cohesion. *Public Personnel Management*, 20(1), 195-205.
- [11] Brayfield, A. H., & Rothe, H. F. (1951). An index of job satisfaction. *Journal of Applied Psychology*, 35, 307-311. doi: 10.1037/h0055617
- [12] Bretz, R. D., Ash, R. A., & Dreher, G. F. (1989). Do people make the place? An examination of the attraction-selection-attrition hypothesis. *Personnel Psychology*, 42, 561-581.
- [13] Bretz, R. D., & Judge, T. A. (1994). Person-organization fit and the theory of work adjustment: Implications for satisfaction, tenure, and career success. *Journal of Vocational Behavior*, 44, 32-54.
- [14] Brown, S. P., & Peterson, R. A. (1993). Antecedents and consequences of salesperson job satisfaction: metaanalysis and assessment of causal effects. *Journal of Marketing Research*, 30, (1), 63-77.
- [15] Brown, S. P., & Peterson, R. A. (1994). The effect of effort on sales performance and job satisfaction. *Journal of Marketing*, 58(2), 70-80.
- [16] Burke, R. J., Deszca, G., & Weitzel, W. (1982). Subordinate expectations and satisfaction with the performance appraisal interview. *Journal of Psychology*, 111, 41-49.
- [17] Cable, D. M., & Judge, T. A. (1994). Pay Preferences and job search decisions: A person-organization fit perspective. *Personnel Psychology*, 47, 317-348.
- [18] Cable, D. M., & Judge, T. A. (1996) Person-Organization Fit, Job Choice Decisions, and Organizational Entry, *Organizational Behavior and Human Decision Processes*, 67 (3), 294-311.
- [19] Cable, D. M., & DeRue, D. S. (2002). The convergent and discriminant validity of subjective fit perceptions. *Journal of Applied Psychology*, 87, 875-884.
- [20] Cameron, K. S., & Freeman, S. J. (1991). Cultural Congruence, Strength, and Type: Relationships to Effectiveness. *Research in Organizational Change and Development*, 5, 23-58.
- [21] Cameron, K. S., & Quinn, R. E. (2005). *Diagnosing and changing organizational culture: Based on the competing values framework*. San Francisco, CA: Jossey-Bass.
- [22] Cammann, C., Fichman, M., Jenkins, G. D., Jr., & Klesh, J. R. (1979). *The Michigan Organizational Assessment Questionnaire*. Unpublished manuscript, University of Michigan.
- [23] Carless, S. A. (2005). Person-job fit versus person-organization fit as predictors of organizational attraction and job acceptance intentions: A longitudinal study. *Journal of Occupational and Organizational Psychology*, 78, 411-429.
- [24] Chatman, J. A. (1989). Improving interactional organizational research: A model of person-organization fit. *Academy of Management Review*, 14, 333-349.
- [25] Chatman, J. A. (1991). Matching people and organizations: Selection and socialization in public accounting firms. *Administrative Science Quarterly*, 36, 459-484.
- [26] Christiansen, N., Villanova, P., & Mikulay, S. (1997). Political influence compatibility: Fitting the person to the climate, *Journal of Organizational Behavior*, 18, 709-730.
- [27] Cropanzano, R., Prehar, C., & Chen, P. Y. (2002). Using social exchange theory to distinguish procedural justice from interactional justice. *Group and Organizational Management*, 27, 324-351.
- [28] Currivan, D. B. (2000). The Causal Order of Job Satisfaction and Organizational Commitment in Models of Employee Turnover. *Human Resource Management Review*, 9(4), 495-524.
- [29] Downey, H. K., Hellriegel, D., & Slocum, J. W. Jr. (1975). Congruence between individual needs, organizational climate, job satisfaction and performance. *Academy of Management Journal*, 18, 149-155.

- [30] Dutton, J. E., & Heaphy, E. D. (2003). The power of high quality connections. In Cameron, K., J.E. Dutton, and R.E. Quinn (Eds.), *Positive Organizational Scholarship* (pp. 263-278). San Francisco, CA: Berrett-Koehler Publishers.
- [31] Edwards, J. R. (1991). Person-job fit: A conceptual integration, literature review, and methodological critique. In C. L. Cooper and I. T. Robertson (Eds.), *International review of industrial and organizational psychology* (pp. 283-357). New York: John Wiley and Sons.
- [32] Emmons, R. A., Diener, E., & Larsen, R. J. (1986). Choice and avoidance of everyday situations and affect congruence: Two models of reciprocal interactionism. *Journal of Personality and Social Psychology*, 51, 815-826.
- [33] Farkas, A., & Tetrick, L. E. (1989). A Three-Wave Longitudinal Analysis of the Causal Ordering of Satisfaction and Commitment on Turnover Decision. *Journal of Applied Psychology*, 74(6), 855-868.
- [34] Gagne', M., & Deci, E. L. (2005). Self-determination theory and work motivation. *Journal of Organizational Behavior*, 26, 331-362.
- [35] Gilbert, N. M., & Sneed, J. (1992). Organizational culture: does it affect employee and organizational outcomes? *Journal of the Canadian Dietetic Association*, 53(2), 155-158.
- [36] Gill, H., & Finegan, J. E. (2000, April). The relation between person-organization fit and organizational commitment. Paper presented at the 15th Annual Conference of the Society for Industrial and Organizational Psychology, New Orleans, LA.
- [37] Glasser, W. (1965). *Reality Therapy: A new approach to psychiatry*. New York: Harper & Row.
- [38] Hackman, J. R., & Oldham, G. R. (1975). Development of the Job Diagnostic Survey. *Journal of Applied Psychology*, 60, 159-170.
- [39] Harris, S. G., & Mossholder, K. W. (1996). The affective implications of perceived congruence with culture dimensions during organizational transformation. *Journal of Management*, 22, 527-547.
- [40] Hofstede, G. H., Neuijen, B., Ohayv, D. D., & Sanders, G. (1990). *Measuring Organizational Cultures: A Qualitative Study Across Twenty Cases*. *Administrative Science Quarterly*, 35, 286-316.
- [41] Hoppock, R. (1935). *Job satisfaction*. New York: Harper and Brothers Publishers.
- [42] Hwang, I., & Chi, D. (2005). Relationships among internal marketing, employee job satisfaction and international hotel performance: an empirical study. *International Journal of Management*, 22(2), 285-293.
- [43] Hulpia, H., Devos, G., & Rosseel, Y. (2009). The relationship between the perception of distributed leadership in secondary schools and teachers' and teacher leaders' job satisfaction and organizational commitment. *School Effectiveness and School Improvement*, 20(3), 291-317.
- [44] Igbaria, M., & Greenhaus, J. H. (1992). Determinants of MIS employees' turnover intentions: A structural equation model. *Communications of the ACM*, 35(2), 35-49.
- [45] Ironson, G. H., Smith, P. C., Brannick, M. T., Gibson, W. M., & Paul, K. B. (1989). Construction of a Job in General Scale: A comparison of global, composite, and specific measures. *Journal of Applied Psychology*, 74, 193-200.
- [46] Ivancevich, J. M., & Matteson, M. T. (1984). A Type A-B person-work environment interaction model for examining occupational stress and consequences. *Human Relations*, 37, 491-513.
- [47] Jiang, J. J., & Klein, G. (2000). Supervisor Support and Career Anchor Impact on the Entry-Level IS Professionals' Career Satisfaction. *Journal of Management Information Systems*, 16(3), 219-240.
- [48] Judge, T. A., & Bretz, R. D. (1992). Effects of work values on job choice decisions. *Journal of Applied Psychology*, 77, 261-271.
- [49] Judge, T. A., & Cable, D. M. (1997). Applicant personality, organizational culture, and organizational attraction. *Personnel Psychology*, 50, 359-384.
- [50] Judge, T. A., Kristof-Brown, A., & Darnold, T. (2005, April). Person-organization goal fit and job satisfaction: Role of motives underlying goal pursuit. Paper presented at the 20th Annual Conference of the Society for Industrial and Organizational Psychology, Los Angeles, CA.

- [51]Katz, D. (1964). The Motivational Basis of Organizational Behavior. *Behavioral Science*, (9), 131-133.
- [52]Knoke, D., & Wright-Isak, C. (1982). Individual Motives and Organization Incentive Systems. *Research in the sociology of organizations*, 1, 209-254.
- [53]Knoop, R. (1995). Relationships among job involvement, job satisfaction, and organizational commitment for nurses. *The Journal of psychology*, 129(6), 643-649
- [54]Kolenko, T. A., & Aldag, R. J. (1989). Congruence perceptions and managerial career/work outcomes: An exploratory analysis. Paper presented at the meeting of the National Academy of Management, Washinton, D.C.
- [55]Koslowsky, M., Caspy, T., & Lazar, M. (1991). Cause and effect explanations of job satisfaction and commitment: The case of exchange commitment. *The Journal of Psychology*, 125(2), 153-162.
- [56]Kreitner, R., & Kinichi, A. (1995). *Organization Behavior*. Boston: Richard, D. Irwin.
- [57]Kristof, A. L. (1996). Person-Organization Fit: An Integrative Review of Its Conceptualization, Measurement, and Implications. *Personnel Psychology*, 49, 1~43.
- [58]Kristof-Brown, A. L. (2000). Perceived applicant fit: Distinguishing between recruiters' perceptions of person-job and person-organization fit. *Personnel Psychology*, 53(3), 643-671.
- [59]Kwantes, C. T., & Boglarsky, C. A. (2007). Perceptions of organizational culture leadership effectiveness, and personal effectiveness across six countries. *Journal of International Management*, 13(2), 204-230.
- [60]Locke, E. A. (1969). What is job satisfaction? *Organizational Behavior and Human Performance*, 4, 309-336.
- [61]Lok, P., & Crawford, J. (2001). Antecedents of organizational commitment and the mediating role of job satisfaction. *Journal of Managerial Psychology*, 16(8), 594-613.
- [62]Lok, P., & Crawford, J. (2004). The effect of organizational culture and leadership style on job satisfaction and organizational commitment: a cross-national comparison. *Journal of Management Development*, 23(4), 321-38.
- [63]Louis, M. R. (1980). Surprise and sense-making: what newcomers experience and how they cope in unfamiliar organizational settings. *Administrative Science Quarterly*, 25, 226-251.
- [64]Louis, M. R. (1990). Acculturation in the workplace: Newcomers as lay ethnographers. In B. Schneider (Ed.), *Organizational climate and culture* (pp. 85-129). San Francisco, CA: Jossey-Bass.
- [65]Lauver, K., & Kristof-Brown, A. (2001). Distinguishing between employees' perceptions of person-job and person-organization fit. *Journal of Vocational Behavior*, 59(3), 454-470.
- [66]Lawler, E. J., & Yoon, J. (1998). Network structure and emotion in exchange relations. *American Sociological Review*, 63, 871-894.
- [67]Mathieu, J. E., & Zajac, D. M. (1990). A Review and Meta-analysis of the Antecedents, Correlates, and Consequences of Organizational Commitment. *Psychological Bulletin*, 108, 171-194.
- [68]Mathieu, J. E., & Hamel, K. (1989). A causal model of the antecedents of organizational commitment among professionals and nonprofessionals. *Journal of Vocational Behavior*, 34, 299-317.
- [69]Meglino, B. M., Ravlin, E. C., & Adkins, C. L. (1989). A work values approach to corporate culture: A field test of the value congruence process and its relationship to individual outcomes. *Journal of Applied Psychology*, 74, 424-432.
- [70]Meyer, J. P., & Allen, N. J. (1991). A three-component conceptualization of organizational commitment. *Human Resource Management Review*, 1(1), 61-98.
- [71]Meyer, J. P., & Allen, N. J. (1997). *Commitment in the Workplace, Theory, Research and Application*. Thousand Oaks, CA: SAGE.
- [72]Morris, J. H., & Sherman, J. D. (1981). Generalizability of an Organizational Commitment model. *Academy of Management Journal*, 24(3), 512-526.

- [73] Mowday, R. T., Steers, R. M., & Porter, L. M. (1979). The measurement of organizational commitment. *Journal of Vocational Behavior*, 14, 224-247.
- [74] Mowday, R. T., Porter, L. M., & Steers, R. M. (1982). *Employee Organization Linkages: The Psychology of Commitment, Absenteeism and Turnover*. New York: Academic Press.
- [75] Odom, R. Y., Boxx, W. R., & Dunn, M. G. (1990). Organizational culture, commitment, satisfaction, and cohesion. *Public Productivity & Management Review*, 14(2), 157-179.
- [76] O'Reilly, C. A., & Chatman, J. A. (1986). Organizational commitment and psychological attachment: The effects of compliance, identification and internalization on prosocial behavior. *Journal of Applied Journal*, 71, 487-516.
- [77] O'Reilly, C. A., Chatman, J., & Caldwell, D. F. (1991). People and organizational culture: A profile comparison approach to assessing person-organization fit. *Academy of Management Journal*, 34(3), 487-516.
- [78] Organ, D. W. (1988). *Organizational Citizenship Behavior: The Good Solider Syndrome*. Lexington, MA: Lexington Books.
- [79] Pervin, L. A., & Rubin, D. B. (1967). Student dissatisfaction with college and the college dropout: A transactional approach. *Journal of Social Psychology*, 72, 285-295.
- [80] Pfeffer, J., & Salancik, G.R. (1978). *The external control of organizations: A resource dependence perspective*. New York: Harper & Row publishers.
- [81] Pondy, L. R., & Mitroff, I. I. (1979). Beyond open systems models of organization. In B.M. Staw (Ed.) *Research in organizational behaviour* (pp. 3-39), Greenwich: JAI Press.
- [82] Porter, L. W., & Lawler, E. E. (1971). *Managerial Attitudes and Performance*. Homewood, IL: Richard D. Irwin.
- [83] Porter, L. W., Steer, R. M. & Boulian, P. V. (1974). Organizational Commitment, Job Satisfaction and Turnover Among Psychiatric Technicians. *Psychiatric Technician*. *Journal of Applied Psychology*, 59, 603-609.
- [84] Posner, B. Z., Kouzes, J. M., & Schmidt, W. H. (1985). Shared values make a difference: An empirical test of corporate culture. *Human Resource Management*, 24, 293-309.
- [85] Posner, B. Z. (1992). Person-organization values congruence: No support for individual differences as a moderating influence. *Human Relations*, 45(4), 351-361.
- [86] Quinn, R. P., Graham, L. S., & McCullough, M. R. (1974). *Job satisfaction: Is there a trend?* Washington, DC: U.S. Department of Labor.
- [87] Quinn, R. E., & McGrath, M. R. (1985). The Transformation of Organizational Cultures: A Competing Value Perspective. In P. J. Forst; L. F. Moore; M. R. Louis; C. C. Lundberg; J. Martin, eds., *Organizational Culture* (pp. 315-334). Beverly Hill, CA: SAGE.]
- [88] Richard, P. J., Devinney, T. M., Yip, G. S., & Johnson, G. (2009). Measuring organizational performance: Towards methodological best practice. *Journal of Management*, 35(3), 718-804.
- [89] Riechers, A. E. (1985). A Review and Reconceptualization of Organization Commitment. *Academy of Management Review*, 10, 465-476.
- [90] Russell, S. S., Spitzmuller, C., Lin, L. F., Stanton, J. M., Smith, P. C., & Ironson, G. H. (2004). Shorter can also be better: The abridged job in general scale. *Educational and Psychological Measurement*, 64(5), 878.
- [91] Rynes, S. L., & Gerhart, B. (1990). Interviewer assessments of applicant fit: An exploratory investigation. *Personnel Psychology*, 43, 13-35.
- [92] Sagie, A. (1998). Employee absenteeism, organizational commitment, and job satisfaction: Another look. *Journal of Vocational Behavior*, 52(2), 156-171.
- [93] Schein, E. H. (1985). *Organizational culture and Leadership*. (1rd ed.). San Francisco, CA: Jossey-Bass.
- [94] Schein, E. H. (1992). *Organizational Culture and Leadership*. (2rd ed.). San Francisco, CA: Jossey-Bass.
- [95] Schein, E. H. (1996). Culture: The missing concept in organization studies. *Administrative Science*

Quarterly, 41(2), 229-231.

[96] Schneider, B. (1987). The people make the place. *Personnel Psychology*, 40, 437-454.

[97] Selznick, P. (1957). *Leadership in Administration: A Sociological Interpretation*. New York: Harper & Row.

[98] Shea, J. (1997). Instrument Relevance in Multivariate Linear Models: A Simple Measure. *Review of Economics and Statistics*, 79(2), 348-352.

[99] Shore, L. M. & Martin, H. J. (1989). Job satisfaction and organizational commitment in relation to work performance and turnover intentions. *Human Relations*, 42(7), 625-638.

[100] Silverthorne, C. (2004). The Impact of Organizational Culture and Person-Organization Fit on Organizational Commitment and Job Satisfaction in Taiwan. *Leadership and Organization Development Journal*, 25(7/8), 592-599.

[101] Smircich, L. (1983). Concepts of culture and organizational analysis. *Administrative Science Quarterly*, 28, 339-358. doi:10.2307/2392246

[102] Smith, P. A., Kendall, L. M., & Hulin, C. L. (1969). *Measurement of Satisfaction in Work and Retirement*. Chicago: Rand McNally.

[103] Smith, C. A., Organ, D. W., & Near, J. P. (1983). Organizational Citizenship Behavior: Its nature and antecedents. *Journal of Applied Psychology*, 68, 653-663.

[104] Spector, P. E. (1985). Measurement of human service staff satisfaction: Development of the job satisfaction survey. *American Journal of Community Psychology*, 13(6), 693-713.

[105] Steers, R. M. (1977). Antecedents and Outcomes of Organizational Commitment. *Administrative Science Quarterly*, 22, 46-56.

[106] Steers, R. M., & Porter, L. W. (1983). *Motivation and Work Behavior* (3th ed.). New York: McGraw-Hill.

[107] Tom, V. (1971). The role of personality and organizational images in the recruiting process. *Organizational Behavior and Human Performance*, 6,

573-592.

[108] Turban, D. B., & Keon, T. L., (1993). Organizational attractiveness: An interactionist perspective. *Journal of Applied Psychology*, 78, 184-193.

[109] Tziner, A. (1987). Congruency issue retested using Fineman's achievement climate notion. *Journal of Social Behavior and Personality*, 2, 63-78.

[110] Vancouver J. B., & Schmitt, N. W. (1991). An exploratory examination of person-organization fit: Organizational goal congruence. *Personnel Psychology*, 44, 333-352.

[111] Vancouver, J. B., Millsap, R. E., & Peters, P. A. (1994). Multilevel analysis of organizational goal congruence. *Journal of Applied Psychology*, 79, 666-679.

[112] Van Vianen, A. E. M. (2000). Person-organization fit: The match between newcomers' and recruiters' preferences for organizational cultures. *Personnel Psychology*, 53(1), 113-149. doi: 10.1111/j.1744-6570.2000.tb00196.x

[113] Verquer, M. L., Beehr, T. A. & Wagner, S. H. (2003). A meta-analysis of relations between person-organization fit and work attitudes. *Journal of Vocational Behavior*, 63, 473-489. [http://dx.doi.org/10.1016/S0001-8791\(02\)00036-2](http://dx.doi.org/10.1016/S0001-8791(02)00036-2)

[114] Vroom, V. H. (1964). *Work and motivation*. New York: Wiley.

[115] Wallach, E. (1983). Individuals and Organization: The Cultural Match. *Training and Development Journal*, 37(2), 29-36.

[116] Warr, P., Cook, J., & Wall, T. (1979). Scales for the Measurement of Come Work Attitudes and Aspects of Psychological Well-Being. *Journal of Occupational Psychology*, 52, 129-148.

[117] Weiss, D. J., Dawis, R. V., England, G. W., & Lofquist, L. H. (1967). *Manual for the Minnesota Satisfaction Questionnaire*. Minnesota Studies in Vocational Rehabilitation: XXII, University of Minnesota.

[118] Werbel, J. D., & Johnson, D. J. (2001). The use of person-group fit for employment selection: A



missing link in person-environment fit. *Human Resource Management*, 40(3), 227.

[119] Westerman, J. W., & Cyr, L. A. (2004). An integrative analysis of person-organization fit theories. *International Journal of Selecting and Assessment*, 12, 252-261.

[120] Whyte, W. H. (1956). *The Organization Man*. New York: Simon and Schuster.

[121] Wilkins, A. L., & Ouchi, W. G. (1983). Efficient Cultures: Exploring the Relationship Between culture and organizational performance. *Administrative Science Quarterly*, 28, 468-481.

## **Political Science**

# The Role of People's Republic of China in Contemporary Canadian Foreign Policy: Canada-China Relations in the 21<sup>st</sup> Century

Tomasz Soroka

Jagiellonian University, Krakow, Poland  
[tomasz.soroka@uj.edu.pl](mailto:tomasz.soroka@uj.edu.pl)

## Abstract

*Since the end of the Cold War, China has played an increasingly important role in global geopolitics and has become a major focus point for world's most prominent political leaders. Canada also appears to have found its stable position in world's affairs and today serves as a typical example of a selective or specialized power. The article below discusses Canada-China relations from the most contemporary perspective, trying to evaluate the place of today's People's Republic of China (PRC) in the Canadian foreign policy. The paper analyzes different aspects of bilateral relations, including: human rights and democracy, economy and trade, the Chinese Canadians' lobbying potential and their influence on Ottawa's policies towards PRC. The article also provides an overview of the evolution of Canada-China relations and presents Canadian public opinion's attitudes towards China.*

## 1. Introduction

The changing and dynamic structure of the world after the Cold War has led to the present situation where China plays an increasingly important role in shaping geopolitical decisions across the globe and has become a major focus point for diplomats and politicians representing the most powerful countries and international organizations. Moving away from the bipolar model has enabled China to challenge the U.S. economic dominance and become the world's second largest economy. Canada – though being very different from China in terms of democratic standards, political traditions and practices, or economic and social structures – has also benefitted from a new post-Cold War formula of international relations. Given its rather modest demographic potential (around 34 million inhabitants), Canada occupies a disproportionately prominent position in world's affairs: the country is a member of prestigious G8 and G20 groups and belongs to NATO and NORAD, the largest military alliances in the

modern age. Thanks to Canada's skilful use of its soft power and material resources (natural gas and oil, for instance), the Maple Leaf country's international position seems to perfectly meet the definition of what some political analysts and scholars (Robert Keohane, Joseph Nye) call a selective or specialized power – a country building its position as an energy and technological superpower, using rather soft diplomacy than military resources to gain prominence [1]. Canada and China are thus important actors on international scene and their contemporary bilateral relations deserve a careful analysis as they might soon become an important determinant of international relations.

## 2. Overview of historical bilateral relations

The Chinese presence in Canada dates back to the late 18<sup>th</sup> century when the first Chinese immigrants were recorded to arrive in what today is British Columbia's Pacific Coast to work as a cheap, physical labor force in local shipyards and trading posts. However, large-scale Chinese immigration to Canada started no sooner than in mid-19<sup>th</sup> century. The first waves of settlers from China were attracted to western Canada by the gold rush and their techniques of extracting gold from sands were initially widely appreciated across the Pacific region. The second (and more important) incentive for Chinese immigrants was a construction of the Canadian Pacific Railway (CPR) – a transcontinental rail track connecting Canadian Atlantic and Pacific coasts and at the same time one of the largest and most meaningful infrastructure projects in Canadian history. Unable to find workers elsewhere and desperate to cut the costs of the investment, the Canadian government contracted several thousand laborers from China in the early 1880s. They were made responsible for building the most demanding section of the railway across the Canadian Cordillera [2]. Exposed to an exhaustive physical effort and extremely severe climate, paid starving salaries, and

housed in alarming conditions, many of them deserted or fell ill and approximately 600 died.

Once the CPR had been completed in 1885, the great masses of Chinese contracted workers were made redundant. Given the fact that both the trans-Canada railway and the gold rush contributed to a rapid growth of the Chinese population in Canada's West, the local public opinion first and the Canadian government later started to perceive the unemployed Chinese as an unnecessary burden on the country's economy. More and more frequently Sino-Canadians fell victims of racial discrimination and prejudice. Ethnic tensions reached their climax in September 1907 when the Asiatic Exclusion League, an organization formed to deter Asians from settling in Canada, held anti-Chinese riots resulting in the demolition of Vancouver's Chinatown. Canadian politicians gradually yielded to the demands of white Canadian racists – in the years 1885-1923, the Canadian Parliament passed a series of immigration laws imposing fixed charges (head taxes, as they were called) on Chinese persons arriving in Canada. In 1923 the Canadian government followed the U.S. pattern and passed the most restrictive law (*The Chinese Exclusion Act*), which virtually banned all Chinese immigrants from Canada [2]. According to Fred Edwards, there were only eight Chinese immigrants admitted to Canada in the years 1924-40 [3].

As for Canada-China official diplomatic relations, these were established no sooner than in 1970. There are a couple of arguments explaining this somewhat belated process. Most importantly, Canada as a British dominion had no formal status in international affairs and could not establish independent relations with any foreign country; Canada's political and diplomatic interests were represented by the UK government and British officials. Only after the passage of the Statute of Westminster (1931) by the British parliament, Canada and five other self-governing dominions (i.e. Australia, New Zealand, South Africa, Ireland, and Newfoundland) gained full independence in foreign affairs and diplomacy. This, however, had no positive impact on Canada's relations with China, mainly because Canadian governments of the interwar years decided to use the newly acquired independence to move Canada into the U.S.-style isolationism. Such approach meant that little interest was shown in Ottawa for Asia (the priority was to discourage Asian immigrants), with the policy of indifference (or appeasement, if one prefers) being adopted by Canada towards Asian military conflicts. Such political strategy turned out to be largely unsupportive of the Chinese

opposition to Japan's invasion of Manchuria in 1931 [3].

The Second World War, for a short time, made Canada and China political and military allies. Canadian and Chinese forces fought side by side against Japanese aggressions in Southeast Asia; some Sino-Canadians were even recruited to the Canadian Army. The wartime experiences also played a significant role in the removal of the discriminatory, racially-based immigration laws - the ban on Chinese immigration was lifted in Canada and Sino-Canadians became fully enfranchised in 1947 [2].

The short-lived thaw in bilateral relations ended, however, with the advent of the Cold War, which again pitted Canada and China against each other. In the early Cold War years the Canadian government, outraged by the large-scale communist espionage activities in Canada revealed by Igor Gouzenko (an employee of the Soviet Embassy to Canada who defected in September 1945 to Canadian authorities), took a strongly anticommunist position. Following the policies of other powers in the Western Bloc, Canada refused to recognize the PRC as the legitimate successor of the prewar China. Instead, Ottawa preferred to collaborate with Taiwan, the PRC's antagonist. Furthermore, as F. Edwards put it, "Beijing's repeated military shocks – intervention in Korea, shelling in the Taiwan in 1954, the invasion of Tibet in 1959, war with India in 1962, a nuclear test in 1964, support for the Vietnamese Communists in the 1960s (...) – ensured that the political and diplomatic climate would remain hostile" to the official recognition of the PRC [3].

The breakthrough in bilateral relations was achieved in the late 1960s, mainly due to a coincidence of two important political factors: a) the arrival of Pierre Trudeau as Canadian prime minister in 1968 and the "Third Option" policy adopted by his cabinet in 1972 (an initiative aimed at decreasing Canadian dependence on American economy and culture); b) China's doctrinal split with the USSR in 1960s, resulting in the Sino-Soviet political rivalry in consecutive decades. Under such new circumstances, Canada saw a chance of diversifying its trade by extending business relationships with China, while the PRC sought to mend relations with the major Western bloc countries as it could not remain in open conflict with both the USSR and the West. Thus, the ground was laid for the official establishment of diplomatic relations between Canada and China in 1970, the exchange of ambassadors a year later, and for mutual visits by numerous high-ranking politicians that took place in the following years [4]. All these helped to

develop stable economic and cultural relations, though economic stability not always equals political cordiality. Both countries remained on opposite sides of a debate over such issues as human rights, the rule of law and democracy, civil rights and political freedoms. At the same time the consecutive Chinese and Canadian governments worked hard not to allow political divergences to overshadow mutual economic interests and bilateral trade. Economic relations developed rapidly after 1976 when Deng Xiaoping took over the Chinese leadership and implemented reforms which gradually opened China's economy to the world. This way Trudeau's prophecy that China – if engaged in world's affairs and not isolated from international community – would one day bring its economic practices "into harmony with international norms" was at least partially fulfilled [3].

In 1980s and 1990s Canadians took many political measures to boost bilateral economic relations. In 1984 the Asia Pacific Foundation of Canada was established by Canadian parliament to serve as "an independent, not-for-profit think-tank" providing "current and comprehensive research, analysis and information" on Asia [38]. A decade later Team Canada missions were invented under Jean Chrétien's premiership (1993-2003). Initially, they were missions (foreign trips of Canada's most prominent political and business figures, including the federal prime minister, cabinet ministers, provincial and territorial premiers, business representatives) promoting Canadian business and investment only in China. Having turned out to be very successful (Chinese-Canadian bilateral trade increased from \$2 billion in 1989 to \$17.5 billion in 2001 [3]), the missions have recently become a wider strategy of dealing with all Canada's most important economic partners. In general, Canada-China relations in the period 1970-2006 constantly and steadily improved; in 2005 they were even officially upgraded by both sides to a "strategic partnership", which – according to W. Jiang – is a status reserved only "for Beijing's most important and trustworthy international partners" [12]. Friendliness and sympathies, however, stopped being so meticulously cultivated in Ottawa after 2006 when Conservatives led by Stephen Harper, the incumbent prime minister, took power.

### **3. Human rights, democracy and political divergences**

Having gained power in Canada, the new Harper administration were no longer interested in the continuation of the "economy first, human rights second" policies of the previous Liberal cabinets. At

least the initial three years of Stephen Harper's premiership were marked by hostilities and tense relations with China, resulting mainly from a harshly critical view Ottawa took on Beijing's human rights record. While economy and trade relations with China mattered, declared Stephen Harper in the announcement of Ottawa's reversed approach to the PRC, important Canadian values (human rights included) would never be sold out by his government "to the almighty dollar" [3]. The statement was followed by an array of actions regarded by the PRC's authorities as disrespectful and disagreeable.

In September 2006, Canadian authorities officially hosted Tenzin Gyatso, the 14th Dalai Lama. The Tibetan exile leader was invited to Vancouver to open the first institution named after him – The Dalai Lama Centre for Peace and Education. He was also bestowed an honorary Canadian citizenship by Canada's parliament "as one of the world's leading champions of peace and non-violence" [5]. A year later Ottawa continued to ignore Chinese warnings that Dalai Lama's Canadian visits would further deteriorate Canada-China relations. The Tibetan monk was again invited, this time to Ottawa, where he held talks with Prime Minister S. Harper. To the astonishment of Chinese authorities, one of Harper's cabinet ministers issued an ominous sounding press statement after the meeting in which he hoped that "the entire world gets the message that attacking a 72-year-old pacifist Buddhist monk who advocates nothing more than cultural autonomy for his people, is counterproductive". The Chinese government expressed their "strong dissatisfaction", accusing Ottawa of "gross interference" in Chinese internal affairs and supporting "the Dalai Lama's separatist activities". Beijing called on Ottawa to "reflect on and correct the erroneous actions" [6].

Another irritant for China was the Canadian policy towards Taiwan (officially the Republic of China, ROC), an island treated by Beijing as the PRC's province whose independence Beijing has consistently refused to recognize. Furthermore, the PRC's authorities demand that all the countries having official relations with Beijing respect a so-called "One China policy" and, in so doing, avoid maintaining any formal diplomatic relations with the ROC. Therefore, in 2007 the PRC government protested strongly against the Canadian parliamentarians' regular visits to Taiwan sponsored by pro-Taiwanese organizations. While reassuring that such trips were of a merely cultural, economic and purely non-political nature, Canadian government also declared that Canada's MPs are free to visit any country of their choice. Peter MacKay's

(Canadian foreign minister) reiteration that Canada's official position remained unchanged ("We have not officially recognized Taiwan ever") was not accepted by Chinese diplomats, who "expressed their displeasure" and again accused Ottawa of "damaging Sino-Canadian relations and stability in the Taiwan Strait." "As elected representatives in Parliament, no matter what they call it," said the Chinese Foreign Ministry in a statement, "their visits to Taiwan are of an official nature and constitute official contact" [7].

As for the practical repercussions of Canadian uncompromising stance on China's human rights abuses, personal contacts between high-ranking politicians were virtually suspended (Canadian prime minister refused to visit China until December 2009). Political tensions between two countries manifested themselves most blatantly during the Beijing Olympics in 2008. As one of the few leaders, Prime Minister S. Harper decided to boycott the opening ceremonies and is said to have done so over human rights concerns (the boycott was believed to have been the prime minister's reaction to the violent crackdown of mass demonstrations in Tibet in March 2008). As a matter of fact, Stephen Harper denied having been politically motivated while making a decision of not attending the Olympic Games ceremonies. On the other hand, Harper's refusal to discuss the real reasons of his absence from Beijing and elaborate comments he offered on political situation in Tibet, highly critical of the Chinese government, seemed to prove the otherwise. "I would continue to urge China to respect human rights and peaceful protest, not just in Tibet but everywhere," Harper said. "And I would also encourage the government of China to understand that its growing wealth, its growing importance in the world and of course, the profile of the Olympics, will put a greater and greater spotlight on its record in this regard" [8]. While Harper's message was either ignored or manipulated by Chinese authorities, Chinese Internet forums and blogs were flooded with hostile reactions to Canada. As the Canadian *Globe and Mail* reported, Chinese websites described Harper as "just a clown" or the "arrogant" and "shameless" head of "a hooligan government". Some would even encourage Chinese Canadians to "use their legal voting rights to fight back against this ignorance and contempt" [9].

The question is why Canadian policy towards the PRC changed so dramatically under Harper. There were at least two direct reasons or driving forces which reversed Ottawa's attitude to China. One was a report prepared for the Canadian Department of Foreign Affairs and International Trade by Charles Burton, an academic and a diplomat, titled *Assessment of the*

*Canada-China Bilateral Human Rights Dialogue* [10]. The Burton report denounced hitherto strategies of quiet and diplomatic talks with Beijing on human rights issues as ineffective and insufficient. Instead, it proposed to use more forceful persuasion and "to dedicate... (more) resources and expertise in Chinese affairs" in order to make the Chinese change their human rights-related policies.

Another issue that exacerbated relations between Canada and China was the case of Huseyincan Celil (by the Chinese he has been referred to by the name of Yu Shanjiang). Celil is a Xinjiang Uyghur imam who was arrested in China in 1994 for seemingly terrorist activities (killing and kidnapping Chinese diplomats) and for his alleged membership in the East Turkestan Islamic Movement, a separatist organization designated by both China and the United Nation as a terrorist group. In 2000, however, Celil managed to escape from the Chinese detention and arrive in Canada, where he was eventually granted a refugee status and a Canadian citizenship in 2005. A year later he made an unsuccessful attempt of getting his children out of the PRC. While on his way to China, he was arrested by the Uzbek authorities and handed over to Chinese authorities. In April 2007 he was sentenced to life in prison for "separating China and... organizing, leading and participating in terrorist groups, organizations." Throughout the trial and the whole period of Celil's imprisonment, the Chinese refused to recognize his Canadian citizenship (Chinese law does not allow for dual nationality) and, as a consequence, denied him the access to Canadian diplomats and lawyers. Actually, Canadian authorities and Celil's family were for months kept in the dark about charges laid against him or his whereabouts. This sparked Ottawa's protests – Prime Minister Harper issued statements emphasizing that "human rights were more important than the two countries' economic partnership." When the life sentence was announced, Canadian government received it with "deep disappointment". "Chinese authorities have persistently refused to respond adequately to our concerns with respect to due process for this Canadian citizen", said Canadian Foreign Affairs Minister. He also expressed his highly critical opinion of the way the Chinese dealt with allegations that Celil had been tortured in a Chinese prison. Canadian appeals were, however, of no use for the Chinese authorities, who remained steadfast in their conviction that Celil's case was China's internal matter and that "the Canadian side has no right to interfere with the case" [11]. The only promise Beijing was ready to make and keep was abstaining from executing Celil.

Huseyincan Celil's case was, by no means, an isolated one. Diplomatic tensions also emerged in the case of Lai Changxing, a Chinese businessman who was involved in corruption scandals and found refuge in Canada. This time, however, Canadian authorities agreed to extradite Lai to the PRC, provided he would not be sentenced to death (eventually, Lai got a life sentence in May 2012). Nevertheless, as W. Jiang rightly noticed, "there are other people accused of financial crimes in China who have taken refuge in Canada and whose lawyers are using China's human rights record and its incomplete legal protection as the first line of defence" [12].

#### 4. Economic relations

Human rights issues, which for the first part of Harper's premiership constituted a priority in Canada's approach to China, became a less emphasized element of bilateral relations in 2009. Economic pragmatism again prevailed, which helped to improve political atmosphere in bilateral contacts. The reasons for that change were several. The ineffectiveness of Harper's hitherto China policies was one of them. As W. Jiang puts it, "contrary to the prevailing perception that somehow the Harper government has emphasized human rights in its China policy, the Conservatives have done little to advance that goal; ...they have made some grand moral statements regarding China's human rights record but have not implemented tangible projects to advance human rights and democracy in that country" [12]. Other reasons were purely geopolitical and economic. China is the second largest economy in the world, the most populated country and Canada's second most important trading partner (overtaking Japan and European countries); with its rapid growth, the PRC has a chance of becoming the largest economy in a few decades. Chinese increasing consumption makes it a desired place for foreign investments, also for many Canadian companies. Most importantly for Canada, a country rich in natural resources (Canadian government boasts that "Canada is the world's seventh largest crude oil producer and has the second largest proven reserves, ...the third largest natural gas producer, the third largest hydroelectric generator, the largest producer of uranium" [13]), China suffers from huge energy deficits, and that – at least potentially – puts Canada in a position of one of the biggest fuel suppliers to China.

Such solid facts could not be (and were not) ignored by the Harper government, especially when Ottawa declared that trade diversification was to become Canada's primary economic goal. To this end, facing

the world's crisis in 2009, Canada started making stronger efforts to guarantee that the country's economy was made less reliant on trade with the United States (according to Statistics Canada, in 2012, the share of Canada's exports to and imports from the U.S. was 73.2% and 62.5%, respectively [14]). Such efforts even intensified after January 2012, when the Obama administration rejected a Canadian-proposed project called Keystone XL. Keystone is a pipeline system projected to transport Canadian oil from Alberta to refineries in Texas. Given the fact that almost all Canada's exported oil is purchased by the U.S. businesses, Washington's decision (though not final yet) means hugely negative consequences for Canadian economy. Therefore, Canadian government began turning to Asian countries, China included, as alternative markets for Canadian crude oil and other natural resources.

Under such circumstances, the bilateral relationship warmed up considerably, which was marked by a series of mutual high-level visits. Prime Minister Stephen Harper has already visited China twice, in December 2009 and February 2012. This was reciprocated by a Canadian visit of Chinese President Hu Jintao in June 2010. The meetings resulted in a series of economic agreements and initiatives, including: the extension of the Nuclear Cooperation Agreement that will boost Canada's export of its uranium to the PRC; establishing reinforced cooperation in health security sector; signing memoranda of understanding on climate change and cultural exchanges, on ocean science cooperation, or on environmental cooperation [13].

As for 2011, China was Canada's third top export destination (after the U.S and Britain), but at the same time was the largest buyer of Canadian iron and copper ores. The PRC ranked second (overtaken only by the U.S.) on the list of Canadian import sources. Most popular imported goods from China are electronic devices (mobile phones, computers etc.) and sport equipment. The relationship of Canada's imports from and exports to China is strongly negative – China is responsible for Canadian largest merchandise trade deficit (over \$31 billion in 2011) [15].

Although the future of Canada-China economic relations looks promising (a recent report by the Conference Board of Canada, entitled *What Might Canada's Future Exports Look Like?*, expects that by 2025 Canadian trade with China will more than double [16]), there are still contentious issues between Ottawa and Beijing that cannot be relatively easily resolved. One of such issues is Canadian government's repeatedly formulated accusations of Chinese commercial espionage in Canada. In one of his



statements, Prime Minister Harper estimated that “Chinese spies steal \$1 billion worth of technological secrets every month.” The CSIS (Canadian Security and Intelligence Services), in turn, reported that “there could be up to 1000 Chinese agents and informants operating in Canada for the purposes of collecting economic, scientific, and military information.” The charges are so far-reaching that “even China’s efforts to set up Confucius Institutes... are viewed by Canada’s spy agency as a national security concern” [12]. In one of the most recent developments of the espionage scandal, the journalists accredited to the Parliament of Canada who work for Xinhua, a Chinese state-owned press agency, were accused (in October 2012) of tracking and gathering information on Chinese dissidents for Beijing. While no solid evidence confirming the charges was found against Xinhua and the agency kept its unrestricted access to the Parliament’s press gallery, the parliamentary committee promised to have a closer look into the operation of foreign journalists on Parliament Hill in Ottawa [17].

Also, CSIS warned in its report for 2010-11 that certain foreign companies “with close ties to their home governments have pursued opaque agendas or received clandestine intelligence support for their pursuits here” [18]. The warning coincided with an offer from the China National Offshore Oil Corporation (CNOOC) to take over a Canadian oil-and-gas company Nexen. Given the fact that CNOOC is a state-owned Chinese company which has been accused of close collaboration with Beijing in persecuting Chinese dissidents (Falun Gong followers), Canadian public opinion outraged at the prospect of CNOOC becoming involved in Canadian oil sector. In the Ipsos Reid survey [19], conducted in December 2012, 74 per cent Canadians wanted the government to block any acquisitions by foreign government-owned companies (the Canadian *Government’s Investment Canada Act* allows the federal government to block any foreign investment in Canada if it does not provide benefit to Canadian economy). On the other hand, the majority of Nexen’s shareholders agreed to the takeover. Also, it was in Canada’s economic interest “to build bridges with Asian markets that would welcome its energy supplies” [20]. As a result, in December 2012, the government approved the \$15.1 billion worth acquisition of Nexen by CNOOC. *The Economist*, a British weekly magazine, estimated that with this purchase China’s government could control close to 10% of oil exploitation in Canadian tar sands. With the public opinion expressing grave concerns, Prime Minister announced that the government’s

approval was only due to “exceptional circumstances” and that further bids into Canadian oil and gas sector by CNOOC-like foreign state-owned firms will be blocked in the future. “When we say that Canada is open for business, we do not mean that Canada is for sale to foreign governments”, declared Stephen Harper [21].

Another controversial issue is Canadian immigration law, which – at least for some – is too liberal as far as the employment of foreign workers from China is concerned. Particularly in British Columbia, where Chinese-owned businesses operate most actively, the fact that Chinese mining companies bring miners from China while Canadian miners remain unemployed sparks anger and protests. In May 2013, the *Vancouver Sun*’s correspondents obtained letters sent by British Columbians to their provincial government in which they expressed their outrage at Chinese-owned HD Mining for its refusal to give jobs to non-Chinese workers. “We as Canadian citizens,” said one of such letters, “are appalled that the Canadian and B.C. governments would allow foreign workers into Canada to steal away jobs that Canadians are perfectly willing, qualified and able to perform.” The firm, however, defended its employment scheme on the ground that it used specialized techniques unknown in Canada. So far, neither HD Mining nor the B.C. government have backtracked from this specific hiring plan. The latter only reassured about its commitment “to making sure that if these mines are found to be viable, British Columbians will have the opportunity to be trained and employed at these sites” [22].

Also, cybersecurity is a contentious issue in bilateral economic relations. On numerous occasions Canadian officials suggested that China’s government had been deliberately “hacking and invading (Canadian) systems for nefarious purposes” [23]. While Beijing has always denied such accusations (“If you really have the evidence, come [out] with it, if not... shut up”, Chinese ambassador to Canada said on Canadian radio in November 2012 [24]), recent findings released in February 2013 by Mandiant, an American Internet security company, seem to present solid evidence that “a unit of China’s People’s Liberation Army was responsible for computer espionage around the world” [25]. Therefore, Ottawa is particularly careful when it comes to establishing a safe communications system between governmental departments. In this matter Canada appears to be following the footsteps of the U.S. Congressional Committee, which in October 2012 labeled two large Chinese telecommunications and networking companies, Huawei and ZTE, as “national threats”. The

committee argued that telecommunications networks, banking systems and even electrical power grids “could be used by Chinese spies to steal government or commercial secrets if Huawei were permitted to help build networks”. Canadian government seems to have adopted a similar approach, with the exception that for the past several years Canada (especially some provincial governments) has been open wide to Huawei’s or ZTE’s investments. The columnists of *Calgary Herald* pointed out that Huawei “was awarded \$6.5 million grant from the Ontario government” in 2011, and that Bell, Canadian largest telecom firm, uses technology provided by Huawei in setting up its mobile phone network [26]. Canada, thus, still faces challenges as far its own national security is taken into account, and security concerns may continue to be an obstacle for establishing closer economic ties between Canada and the PRC in the near future.

#### **4. Chinese immigration and Chinese Diaspora in Canada**

There is one more important element that can in no way be ignored while analyzing bilateral Canada-China relations and that is the presence of the Chinese in Canada. Until the end of the 1960s, immigration from China was a non-issue for Canadians as Canadian immigration laws were highly restrictive to Asian immigrants and biased in favor of European immigrants. However, in 1967 Canada based its immigration law on a so-called points system – a scheme under which immigrants are admitted to Canada no longer on the basis of their ethnic origin or nationality, but basing on their professional skills, their usefulness in Canadian labor market or their family ties to Canada. This was accompanied with the official implementation of the policy of multiculturalism by P.E. Trudeau’s government in 1971. Both changes removed the last vestiges of institutional ethnic discrimination in Canada and opened doors to the waves of Asian immigrants [2]. This completely altered the ethnic structure of immigration to Canada – among the most recent immigrants, as much as 56.9% are now Asians, while prior to the 1970s Asians accounted only for 8.5% of immigrants [27].

Since the late 1960s, Chinese immigrants have constituted one of the largest groups of foreigners settling in Canada. Between 2002 and 2009, China was the leading source of all newcomers to Canada. According to Citizenship and Immigration Canada’s most recent data, in 2011 alone, almost 29,000 Chinese, or 11.5% of all immigrants, were granted a resident status in Canada (the largest number after the

Filipinos) [28]. Chinese are now also the largest visible minority group in Canada (“visible minority” is a legal term used in Canada in reference to all non-Caucasian, non-white racial minorities except for Aboriginal Peoples), numbering over 1.3 million people [27]. Furthermore, Chinese language (mainly its Cantonese dialect), with over 1.1 million people for whom it is the mother tongue, is the third most frequently spoken language in Canada after English and French [29].

Given such statistics, it is easy to see why the Chinese communities in Canada constitute politically influential groups, whose opinions need to be taken into account by Canadian political elites. In some regions of high concentration of the Chinese, like in Richmond, a suburban area of the Vancouver agglomeration where the Chinese form an overall majority, it is virtually impossible for any political party to achieve an electoral success without positively responding to Chinese-Canadians’ expectations. Some of the Chinese-Canadian societal organizations, like the Chinese-Canadian National Council (CNCC), have become important lobbying groups, successful in forcing Canadian authorities to initiate certain political action. The CNCC, for example, through its active political campaigning, compelled Prime Minister Stephen Harper to offer a formal apology in 2006 for the humiliation the Chinese suffered in the past as the victims of racial discrimination. Not only did the most prominent Canadian politician apologize, not only did he do it in Parliament and spoke the apology in the Cantonese Chinese, but he also agreed to pay compensations to all Chinese survivors who in the past had to pay the infamous head tax [30]. Symbolic as the apology and compensations might have been (there were only 20 survivors, each eligible for a \$20,000 payment), the very fact that apology was issued marked a growing importance of Chinese community in Canada.

The issue of racial discrimination cyclically comes back, whenever the Chinese in Canada fall victims to crime or abuse. The most recent incident of such nature, which caused a sensation worldwide, happened in May 2012. Luka Rocco Magnotta, a Canadian homosexual pornographic actor, brutally murdered Lin Jun, a Chinese international student at Montreal’s Concordia University. Having killed Lin, Magnotta mailed the victim’s dismembered limbs to headquarters of political parties and schools across Canada. As the *Globe and Mail’s* correspondent wrote from Beijing, “the grisly murder... has provoked widespread shock and anger in China, where many believe the crime was racially motivated.” The atrocious criminal act affected political relations. The Chinese Embassy in Canada felt

it proper to issue a warning, reminding “Chinese citizens traveling in Canada, as well as students and the staff of Chinese organizations in Canada, to improve their self-protection [and] awareness, and to strengthen their personal security” [31]. The murder could have had dire consequences for Canadian economy as China, for the previous ten years, had been the top source country of international students either coming to Canada on a yearly basis (almost 22,000 in 2011) [32] or residing in Canada (over 67,000 in the same year) [33]. Given that Canadian government estimates that foreign students “contribute more than \$6.5 billion to the Canadian economy every year”, any drastic drop in the number of students from China would have put the finances of many Canadian universities in a precarious position [34]. However, Ottawa immediately offered its condolences over the murder; Luka Magnotta was arrested and is now (as of June 2013) facing a court trial in Montreal. Also, some Canadian colleges reassured Chinese candidates were welcome and that Canada was a secure and friendly place. All these helped to tone down Chinese negative opinions about Canada.

Despite occasional tensions, Canada has long been a country open to Chinese newcomers. As one of the BBC correspondents reporting from Canada wrote, “Chinese immigrants have flocked to Canada's west coast and transformed Vancouver into Canada's very own Asian metropolis” [35]. “Hongcouver” (as sometimes Vancouver is referred to) or “the University of Billion Chinese” (as the UBC – University of British Columbia – happens to be called) are definitely not the terms to be found on the list of the most politically correct expressions. On the other hand, they make a reference to high numbers of Chinese people living on Canada's Pacific coast; the people who have transformed social and economic landscape of that region [36]. Industrious, hard-working and well-educated as they usually are, Chinese Canadians contribute significantly to British Columbia's prosperity. In one important aspect this positive influence is visible – British Columbia seems to be the closest in all Canada to achieve the goal of diversified economy, i.e. the one not dependent on trade exchange with the U.S. “Our government is focused on making sure British Columbians are first in line to do business with Asia to create jobs here at home,” declared B.C.'s Premier Christy Clark, quoted by BBC, and it was more than a cheap talk; in 2011, for the first time ever, Asia-Pacific region overtook the U.S. as the B.C.'s largest trade partner [35].

A deeper look into the structure of the Chinese community in Canada will show that Chinese-

Canadians do not form a uniform or homogenous group. They differ in many respects – in wealth, religion, education, linguistically (Cantonese vs. Mandarin Chinese); they have come from different Chinese-speaking regions (Mainland China, Hong Kong, Taiwan); they also differ politically, which includes frequently contrasting attitudes towards Chinese communism and the PRC's government. However, majority of them appears to support establishing closer economic and cultural links with the Pacific Rim countries and with China in particular. The most visible effects of that are to be found on a regional or municipal level – Canada has an extensive list of towns and cities which have established twinning partnerships with their Chinese counterparts [13]. Statistics Canada projects the Chinese population in Canada to grow from the present 1.3 million to up to 3 million by 2031 [37]. Thus, it can be expected that Chinese-Canadians will become an increasingly influential ethnic group in Canada, urging Canadian authorities to further relations with China.

Obviously, there have been years of neglect in bilateral relations and serious political divergences exist, which will not be so easily resolved. However, Wenran Jiang in his article in the *International Journal* advises Canadian authorities what to do in order to repair Ottawa-Beijing relationship. The “to do” list includes: a) reviving summit diplomacy with China; b) formulating a nonpartisan China strategy (to set free “from the human rights versus trade argument and avoid treating them as mutually exclusive objectives”); c) promotion of energy cooperation with China; d) developing programs helping China's political transition (“to facilitate positive changes” by respecting China's right to develop independently and with its own pace) [12]. Some of the above recommendations have already been implemented – Harper's government is more involved in diplomatic meetings with China's leaders than a couple of years ago; China has been regarded as an important buyer of Canada's natural resources; Canadian policy towards China has become less biased and more balanced. Only time will show if such strategy is successful and can bring China and Canada closer to each other.

## References

- [1] R. Keohane, J. Nye, *Power and Interdependence*, Longman, New York, 1977.
- [2] P. Li, *The Chinese in Canada*, Oxford University Press Canada, Don Mills, ON, 1998.

- [3] F. Edwards, *Chinese Shadows*, [in:] R. Bothwell (ed.), *Canada Among Nations, 2008: 100 Years of Canadian Foreign Policy*, McGill-Queen's University Press, Montreal, 2009, pp. 293-310.
- [4] C. Burton, *The Canadian Policy Context of Canada's China Policy since 1970*, [in:] V. Poy, H. Cao (eds.), *The China Challenge: Sino-Canadian Relations in the 21st Century*, University of Ottawa Press, Ottawa, 2011, pp. 32-46.
- [5] Canada. Parliament. Senate. *Journals of the Senate*, 39<sup>th</sup> Parliament, 1<sup>st</sup> session, issue 29<sup>th</sup>, 28 June 2006, www.parl.ca.
- [6] "Canadian PM meets Dalai Lama", *The Taipei Times*, The Taipei Times, 31 Oct. 2007, www.taipetitimes.com.
- [7] G. York, "Beijing blasts Ottawa over MPs' visits to Taiwan", *Globe and Mail*, The Globe and Mail Inc., 11 May 2007, www.theglobeandmail.com.
- [8] "PM has no plans to attend Beijing Olympics opening ceremonies", *CBC News*, Canadian Broadcasting Corporation, 4 Apr. 2008, www.cbc.ca.
- [9] G. York, "China twisting Harper's message", *Globe and Mail*, The Globe and Mail Inc., 9 Apr. 2008, www.theglobeandmail.com.
- [10] C. Burton, *Assessment of the Canada-China Bilateral Human Rights Dialogue*, Charles Burton and Associates, St. Catharines, ON, 2006, www.spartan.ac.brocku.ca.
- [11] S. Taylor, "Celil gets life sentence: Canadian citizen sentenced by Chinese government for alleged terrorist activities", *Maclean's*, Rogers Communications, 19 Apr. 2007, www.macleans.ca.
- [12] W. Jiang, "Seeking a Strategic Vision for Canada-China Relations", *International Journal*, vol. 64, no. 4, Canadian International Council, Toronto, Autumn 2009, pp. 891-909.
- [13] Government of Canada. Foreign Affairs and International Trade. *Canada in China*, 2012, www.china.gc.ca.
- [14] Statistics Canada. *Canadian international merchandise trade, February 2013*, 5 Apr. 2013, www.statcan.gc.ca.
- [15] Government of Canada. Department of Foreign Affairs and International Trade. *Canada's State of Trade: Trade and Investment Update 2012*, 30 Apr. 2013, www.canadainternational.gc.ca.
- [16] The Conference Board of Canada. *What Might Canada's Future Exports Look Like?*, Ottawa, November 2012.
- [17] L. Berthiaume, "Chinese news agency Xinhua keeps privileged access to Parliament Hill", *Calgary Herald*, Postmedia Network Inc., 28 Nov. 2012, www.calgaryherald.com.
- [18] T. Parry, "CSIS warns business leaders of Chinese cyber-spies", *CBC News*, Canadian Broadcasting Corporation, 21 Sep. 2012, www.cbc.ca.
- [19] M. Kennedy, "Canadians want Stephen Harper to block foreign investment: poll", *Vancouver Sun*, Postmedia Network Inc., 18 Dec. 2012, www.vancouver.sun.com.
- [20] A. Banerjee, "Ottawa extends review of CNOOC-Nexen deal", *Business News Network*, Bell Media, 5 Nov. 2012, www.bnn.ca.
- [21] "Foreign investment in Canada: Thus far but no further", *The Economist*, The Economist Newspaper Limited, 15 Dec. 2012, www.economist.com.
- [22] J. Keller, "Controversy over Chinese miners in B.C. prompts flood of angry letters", *CTV News*, Bell Media, 31 May 2012, www.ctvnews.ca.
- [23] "MacKay presses Chinese minister on cyberattacks", *CBC News*, Canadian Broadcasting Corporation, 3 June 2013, www.cbc.ca.
- [24] "Prove China spy allegations or 'shut up,' ambassador says", *CBC News*, Canadian Broadcasting Corporation, 17 Nov. 2012, www.cbc.ca.
- [25] J. E. Barnes, S. Gorman, and J. Page, "U.S., China Ties Tested in Cyberspace", *The Wall Street Journal*, Dow Jones & Company, 19 Feb. 2013, www.online.wsj.com.
- [26] M. Kennedy, J. Berkow, "Canada won't say if national security exemption shuts Chinese company out of communications contract", *Calgary Herald*,

Postmedia Network Inc., 10 Oct. 2012, [www.calgaryherald.com](http://www.calgaryherald.com).

[27] Statistics Canada. *2011 National Household Survey: Immigration, place of birth, citizenship, ethnic origin, visible minorities, language and religion*, 8 May 2013, [www.statcan.gc.ca](http://www.statcan.gc.ca).

[28] Government of Canada. Department of Citizenship and Immigration. *Facts and figures 2011 – Immigration overview: Permanent and temporary residents; Canada – Permanent residents by source country*, [www.cic.gc.ca](http://www.cic.gc.ca).

[29] Statistics Canada, Census of Population, 2011. *Table 1: Population of immigrant mother tongue families, showing main languages comprising each family, Canada, 2011*, [www.statcan.gc.ca](http://www.statcan.gc.ca).

[30] P.E. Roy, *The Triumph of Citizenship: The Japanese and Chinese in Canada, 1941-67*, UBC Press, Vancouver, 2007.

[31] M. MacKinnon, “China warns travellers to Canada after killing of student”, *Globe and Mail*, The Globe and Mail Inc., 3 June 2012, [www.theglobeandmail.com](http://www.theglobeandmail.com).

[32] Government of Canada. Department of Citizenship and Immigration. *Facts and figures 2011 – Immigration overview: Permanent and temporary residents; Canada – Total entries of foreign students by source country*, [www.cic.gc.ca](http://www.cic.gc.ca).

[33] Government of Canada. Department of Citizenship and Immigration. *Facts and figures 2011 – Immigration overview: Permanent and temporary residents; Canada – Foreign students present on December 1st by source country*, [www.cic.gc.ca](http://www.cic.gc.ca).

[34] Government of Canada. Department of Citizenship and Immigration. *News Release – Government of Canada works to welcome more Chinese students to Canadian colleges*, 14 Sep. 2010, [www.cic.gc.ca](http://www.cic.gc.ca).

[35] A. Bhatti, “Canada prepares for an Asian future”, *BBC World News*, BBC, 25 May 2012, [www.bbc.co.uk](http://www.bbc.co.uk).

[36] I. Young, “How mainland Chinese immigrants are transforming Vancouver”, *South China Morning Post*,

South China Morning Post Publishers Ltd., 14 Apr. 2013, [www.scmp.com](http://www.scmp.com).

[37] Statistics Canada, *Study: Projections of the diversity of the Canadian population*, 9 Mar. 2010, [www.statcan.ca](http://www.statcan.ca).

[38] Asia Pacific Foundation of Canada. *About Us*, [www.asiapacific.ca](http://www.asiapacific.ca).

## **Some Issues of the Abkhazia Colonization: The Second Half of the 19th Century - Beginning of the 20th Century**

Gela Tsaava

Ivane Javakhishvili Tbilisi State University  
[polge2006@yahoo.com](mailto:polge2006@yahoo.com)

### **Abstract**

*The aspects of the colonial policy of Russia are discussed in the article, reflecting the events of the second half of the 19th century and the beginning of the 20th century. The attempt of Russia to denationalize Abkhazia (Historical part of Georgia) and to assimilate it totally in the Empire space is evident from the material.*

*Tsarist Russia authorities clearly understood the significance of highlanders submission to strengthen firmly in the Caucasus and inevitability of total supremacy in Abkhazia to solve this problem.*

*Russia needed to strengthen at the Black Sea North-East coast and in the West Caucasus to put an end with bullets purchasing and smuggling as well, which inflicted harm to strategic, political and economical interests of the country in the Caucasus.*

*Abkhazia found itself under imperial principle pressure „disconnect and rule over” and Tsarist Russia policy started working with full sharpness to oppose different parts of Georgia, to remove Abkhazia from Georgia and to dissociate local population historically cultural-religiously.*

*Russia never adapted to Georgian ethnic prevails at the territory, which was very important for it and all the more, their opposition to defense own country and people. It was necessary to create conditions to carry out Russian colonization and they fought with all the methods. To create conditions implied first of all prohibition of everything Georgian and who would dare to defense Georgians, to punish them.*

### **1. The beginning of process of the assimilation-colonization of the historical lands of Georgia by empire authorities of Russia**

The aspects of the colonial policy of Russia are discussed in the article, reflecting the events of the second half of the 19th century and the beginning of the 20th century. The attempt of Russia to

denationalize Abkhazia (Historical part of Georgia) and to assimilate it totally in the Empire space is evident from the material.

Abkhazia, Svanetia, and Shida Kartli regions have always been the subject of Russia's permanent and particular interest, as these areas adjoin Kuban, Kabardo, Karachaevo, Circasia, and Ossetia. It was possible to establish influence across Georgia only by controlling the Shida Kartli region. That is the reason why Russia has always had a special administrative relationship with these regions, and has sought to promote a special administrative regime there. It used all available leverage in order to establish its influence and maximally diminish Georgian administration in Abkhazia, Svanetia, and Shida Kartli [3, 11].

In the 30-ies of the 19th century the task of firm strengthening in Abkhazia and Black Sea North-East coast was the major problem of Russia authorities. Positions of Russia in the South Caucasus could not be firm without resolution of this problem, since this place was cut off Empire centre. Therewith, to struggle against West Caucasus highlanders Abaza and Adyghes (Circassians) tribes, Tsarist Russia needed to strengthen at this convenient bridgehead without fail.

At the beginning of the 30-ies of the 19th century command authorities of Russia refrained from broad offensive operations and were content with Anapa and Gagra fortresses guarding. This place still remained for Russia as Achilles heel.

In August 1831 Infantry General, General-Aide-de-Camp, Baron Gr. Rozen was appointed to the post of Vicegerent and Caucasus Corps Commander-in-Chief.

As soon as the new Vicegerent and Caucasus Corps Commander-in-Chief arrived to Tbilisi, he paid special interest to Abkhazia, which, in his opinion, could reach higher prosperity with its location at the Black Sea coast and with natural wealth.

Tsarist Russia authorities clearly understood the significance of highlanders submission to strengthen firmly in the Caucasus and inevitability of total

supremacy in Abkhazia to solve this problem. Russia needed to strengthen at the Black Sea North-East coast and in the West Caucasus to put an end with bullets purchasing and smuggling as well, which inflicted harm to strategic, political and economical interests of the country in the Caucasus.

In the second half of the 19th century Empire authorities of Russia began the process of the assimilation-colonization of the historical lands of Georgia very actively. Well-known Russian historian V. Kliuchevski considered colonization as "main factor of the history of Russia" [6].

At the beginning of 1860 command of Russia stimulated interest in road construction connecting Abkhazia with North Caucasus having not only military and administrative significance but it was important way for final conquest of the country.

In August 1860 the commander of the Russian army, located in Abkhazia, General I. Korganov, arranged punitive expedition in the village Pskhu, 3 thousand militiamen participated in the expedition. At the same time warships of Russia arranged raid at the Ubykhs coast and gave the impression of landing intention. The objective of this operation was to frighten Ubykhs and thus to suppress the possibility of their help to Pskhu inhabitants [5, 36].

In September 1860 Tsar's vice-regent in Caucasus Alexander Baryatinskiy held military meeting in Vladikavkaz to undertake the activities and to end the war in Caucasus rapidly.

At the meeting it was decided to attack from the river Labi and the river Belaya to subdue West Caucasus and to exile Abadzekhs, Shapsukhs, Ubykhs from mountains to the Black Sea.

If they refused to be exiled to the Stavropol province steppe, they would be exiled to Turkey, and the Russians, mainly Cossacks, would be settled at their land. As High Command of Russia considered, without that, conquest of the Caucasus would not be complete and final [5, 36].

In the West Caucasus Russian authorities attached great importance to the Abkhazia factor and the role of Mikheil Sharvashidze. In April 1862 A. Baryatinskiy<sup>69</sup> wrote to D. Miliutin<sup>70</sup>, the Minister of War: "as I know, influence of Mikheil Sharvashidze in Abkhazia and in the neighboring tribes is still important.....therefore, I think the good opinion of us to this man is needed very much" [4, 38].

---

<sup>69</sup> Prince, Russian General-Field-Marshal, in 1856-1862 viceroy in the Caucasus.

<sup>70</sup> Military Man and Statesman of Russia, the Count, General-Field-Marshal, in 1861-1881 Minister of War.

## **2. The implementation of „health-resort colonization” of Abkhazia by empire authorities of Russia**

In 1864, after Abkhazia principality abolition, Tsarist Russia obtained vast territory for colonization and launched the effort of Abkhazia colonization. Tsarist Russia confiscated the estates of the former prince and the members of the princely house. Great number of the "unoccupied lands" arose in Abkhazia. In that period Russia founded more than 35 villages in Abkhazia, which would be rather enough for full colonization of that region. Russian officials wished to turn Abkhazia into their own native land.

In his report of 1864 on Abkhazians eviction and Russian colonization of Abkhazia Kutaisi general-governor D. Sviatopol – Mirski informed: "the only radical way that will decline any danger from the Sukhumi department, - is Abkhazia inhabitant exile to Ottoman Empire, if a part of Abkhazs wants to go to Turkey, we should not prevent. Occupying both shores of Bzipi it will be possible to settle Abkhazia by Russian population" [1].

Thus, according to the Caucasus headquarters plan, West Caucasus mountaineers would be relocated from their dwellings and the Russians settled there.

From 1872 so called "health-resort colonization" was implemented in Abkhazia. From one to three dessiatinas of land, so called "sanitary plots" in Sukhum and its suburbs were given to Russian officials and officers under preferential terms.

In April 1877 Russia-Turkey war began, the field of which became Caucasus as well. From the beginning of the war rather complicated condition was created in Abkhazia. Dissatisfaction provoked by Russia colonial regime reached culmination by that time and revolt began. On April 29, in such strained and complicated situation Turkey landing party landed troops near Gudauta, which was mainly composed of Abkhaz Muhajirs. In April-May Turks had occupied almost whole Abkhazia. At the same time, rebel Abkhazians joined Turks landing party.

From spring 1878 the authorities started practical measures for Abkhazia colonization. In May, 1 1878 the governing board of Pitsunda region made a statement on one year lease of village Anukhvi vineyards and fruit trees gardens. In the Pitsunda region three plots were allocated and granted Russian colonists the possession of land in perpetuity.

In 1879 137 families of Russian peasants were moved into Pitsunda region, but already in 1881 only 99 families remained there. Neither German colonists could settle here. By 1883 only 3 families of 24



German colonists families remained in Abkhazia [1, 58].

Thus, in 60-70-ies of the 19<sup>th</sup> century colonization progress in Abkhazia was insignificant. In spite of Tsarist Russia great desire, colonization of Abkhazia was delayed. Russians could not adapt themselves to natural conditions of Abkhazia – humid climate, forest, mountainous country, marshy shoreline. Wheat harvest could not be collected, the only cereal crop was corn. Tsebelda land, free of malaria, which was spread so much in the shoreline of Abkhazia, was distinguished by healthy, mild climate, rich soil, therefore, bringing of the population could not cause any problem. So, Tsebelda and Dali could become prosperous place - with wonderful vineyards and fruit-trees gardens, mining, but one more and main condition was needed – to build roads. It was difficult for peasants moved from Russia internal provinces to get accustomed with Tsebelda and Dali mountainous conditions.

Despite the fact, that the lands of Abkhazia were given to Russian officials, territory of Abkhazia was not populated, lands were left uncared – for. In Dali, where before Muhajirs of 1867 the population was about 5 thousand, nobody lived even at the end of 19<sup>th</sup> century. Georgian figure Petre Charaia wrote about Dali gorge: "Not long ago Dali was crowded by Abkhazians. In the old days country, famous for bravery of the population is so much neglected today, that nobody lives there" [3, 268].

### **3. The activation of colonization processes of Abkhazia by tsarist Russia vicegerents**

After Russia-Turkey war (1877-1878) Abkhazians were announced to be "guilty population". They were forbidden to settle in 20 km. from Sukhumi and in shoreline between rivers Kodori and Psirtskha. After Abkhaz Muhajirity, when the large part of Abkhazia became depopulated and neglected, and Russians and foreigners did not come here to settle with wish, from West Georgia – from Imereti and Samegrelo - peasants, oppressed with land smallness and bareness, moved and settled in Abkhazia, dried marshes, cut down bushes and managed their estates.

In the 80-ies of the 19<sup>th</sup> century Tsarist Russia abolished ruling by general-governor and reinstated ruling by vicegerent. Reactionary Alexander Dondukov-Korsakov was appointed to the position of vicegerent (1882-1890). He was supported by chauvinists – trustee of the Caucasus educational region (1878-1901) Kiril Ianovski, Egzarkos Paul (1882-1887) and others. First of all Tsarist Russia had

attacked national languages and culture. Colonization process was stirred up.

In 1892 expedition, headed by Minister of Agriculture and State-Owned Property of Russia Alexander Ermolov, inspected Sukhumi region (Abkhazia). Head of the Sukhumi region colonel V. Braker made dinner-party for the members of the expedition, where member of the expedition S. Sharapov delivered his speech and frankly spoke about Russia's intentions in Abkhazia. Particularly, he mentioned: "Through its long historical struggle, aspiring to the South, warm sky and warm sea, people of Russia at the cost of sacrifice at last have this sky and this sea. Here Russian flag flies, Russian eagle waves, but why the Russians do not feel themselves free, why are they oppressed and suffocating? Why are they strange at this warm shore, under the bright sun? I think because owing to Russian kindness here, at this land, which is obtained by Russian blood, every foreigner has settled down at the best places and not only oppresses the Russians but tweaks at them. But it will not last. Our state objectives require this place not only to be named but really to be Russian place soon, the Russians to be here supported, strong and reassured, Gentlemen, let us wish it to come true soon, all local different tribes and different nations mix be cooked in the strong Russian life, this sky and this sea to be really Russian" [5, 59].

In 1896 reactionary Grigori Golitsin was appointed to the position of vicegerent of the Caucasus (1896-1905), and began Russification actively.

Numerous archival data testify that Russian officials groundlessly chased Georgians in Abkhazia. Distinct expression of the Russian colonization real aims is Russian administration attitude towards ethnically Georgian population, living in Sukhumi region, village Parnauti. Facts on so called "Parnauti matter" evidently testify events, happened in the mentioned settlement, that developed as follows: inhabitants, living there, almost totally gave up to muhajir. This place, remaining without inhabitants was almost entirely neglected and became depopulated, soil became unbroken, it needed much labor and means to return economic purpose.

By this reason Russian colonist peasants refused to settle in Parnauti. Also refused to settle there those, who were taken orderly from the Empire internal provinces and were suggested to settle here free of charge. Russian peasants, who were settled in Abkhazia earlier, also refused to settle in this village. By way of exception, following the request-entreaty, Sukhumi forestry allowed Georgian peasants, who mainly had moved from Zugdidi and Senaki, to take a

lease of the land. And, as they were promised, this lease would be eternal or prolonged. But it should be mentioned as well, that Russian peasants were suggested local land free of charge, Georgians were to pay 6 roubles for one dessiatina. Georgians paid also for cattle: 40 copecks for one in a year. Georgian peasants purchased tooling, cultivating the land, while Russian settlers were given free of charge.

Parnauti new settlers applied great efforts to that place. Their merit was that this settlement, which was fully neglected until then, became one of the distinguished places with the blooming gardens and vineyards in the suburbs of Sukhumi. Those people, who had concluded leasing contract with Parnautis, generally, were representatives of the Russian nation or Russian authorities. As it was ascertained afterwards, they had deceived leaseholders, made them to cultivate and make prettier the wild place and then decided to create Russian village at their personal plots. Moreover, they were announced as slyly crept "invaders". Russian officials understood that the issue of colonization was very neat and by authorities it was risky, therefore, it was implemented in the politically advantageous period, when reaction raged, after 1905-1907 Revolution severe suppression [1].

Parnauti peasants did not believe that the circumstances would so much be complicated. Probably, as it can be seen from their activities, they hoped that they would legalize occupied personal plots. At first they wrote requests, complaints and explanations with the help of their representatives, hoped to reach equity, but were finally deceived.

Russian chauvinism was seen also from the fact that Parnauti population was not mentioned in any document as Georgians, they were named Megrels. Russian bureaucracy expressed Empire motto "divide and rule over" in it as well. They divided and named Georgian people as Svans, Imeretians, Megrels, Tushis, Khevsurs, Rachvels and so on, that could not be endured by Georgians.

At last, Russian officials moved a part of Georgians, about 30 families, evicted from Parnauti, to the river Kodori gorge [1].

History of Parnauti is an explicit expression of Russian colonial policy in Abkhazia, Abkhaz and Georgian population pursuit and settlement of the mentioned place by Russians.

#### **4. About intentions of Military governor, General – Major F. Gershelman**

Very interesting information on Russian colonial policy at the first half of the 20th century is given in the archive data of the Ministry.

In 1900 at the Kutaisi province gendarmerie governing board proceedings were initiated against Georgian patriots group, working in Abkhazia (according to the administrative-territorial division of that time Kutaisi province Sukhumi okrug (region)). As it is ascertained from the investigation (according to the investigation data: "Georgian Party Tedo Sakhokia") the leader of this group Tedo Sakhokia with his likeminded persons actively opposed Russian colonial policy in Abkhazia.

Reports, submitted by Kutaisi Military Governor, Major-General F. Gershelman to Kutaisi colonial administration in the process of investigation are very interesting, that were sent from Kutaisi to Tbilisi with "confidential" or "secret" stamp. Therefore, Military Governor, Major-General F. Gershelman spoke openly about imperial plans of Russia in Abkhazia. He knew the essence of the Russia colonial policy perfectly well. He had well comprehended the ways of this policy implementation and those problems that Caucasus colonial administration was faced with in the process of colonization in Abkhazia.

Interesting information on Russia Empire colonial policy in Abkhazia are given in the following documents:

1. Kutaisi Military Governor, Major-General F. Gershelman's report, dated August, 3, 1900 "To the Head of the Caucasus Military-National Board of Administration Ruler's Office." [2, 91].

2. Kutaisi Military Governor, Major-General F. Gershelman's report, dated September, 2, 1900 "On Georgian Movement in the Sukhumi region (okrug)" [2, 91].

Kutaisi Military Governor wrote in September 2, 1900: "Lately, region colonization possibility and obtained use were recognized by Russians, which can be reached, using those territories, that were exempted from the former invaders emigration, affairs in this direction are rather successful and great number of Russian peasants, who expressed the desire for settlement in Sukhumi region, did their part" [2, 91].

Russian Governor forms more clearly the tasks of the colonial policy: Russian colonization of the region has great state significance from the political standpoint. Abkhazs, who are the region population basic mass, until today remain less cultured, less educated nation, from both, development and moral,

standpoints. Everything requires especial attention. The situation can be improved by bringing Russian citizenship in the region, which is gradually implemented in, but still much time is needed to achieve the goal and the best way is region colonization by Russians" [2, 93].

It was clear, that deliverance of Abkhazia from Georgia and local population assimilation would be possible only after Georgian language removal. Following the discussion on the necessity of Georgian language removal from Abkhazia church and schools Kutaisi Military Governor concluded: "Taking such arrangements Sukhumi region local population would be reliably protected from Georgian influence . . . it will not matter for Abkhazs, who have not own written language, know neither Russian nor Georgian language, will their confessor be Russian or Georgian" [2, 94].

Kutaisi Military Governor also touches upon demographic issue and mentions clearly, that by 1900 only in Sukhumi, lived 1500 Georgians (1300 Imeretians, 200 Georgians) besides Megrels. If only in Sukhumi, besides Megrels lived 1500 Georgians, how would 12 Georgians, besides Megrels live in total Sukhumi?. Statistic data should be considered as falsified [2,100].

In his report dated September 2, 1900 Kutaisi Military Governor gives such statistics: population of the Sukhumi region is distinguished by particular variety. Population consists of 96.377 both sexes representatives, where Abkhazs prevail – 71 %, Murzakaneli apply to their number – 37,5 % (Abkhazs – 33,5%, Murzakani – 37,5 %). Russian population is 6% of the total population, Megrels, Imeretians, Gurians and Georgians together are 13% of the population, the rest 10% of the population are the other nations [2, 100].

Military Governor considered Murzakanians as exactly Abkhazs. So he obtained 71%. In fact, the number of the historical Murzakani population-37,5 % - should be added to the Georgians number – 13%, though this last number is evidently reduced.

For the Caucasus colonial authorities, particularly for Kutaisi Military Governor, existed one administrative district – Sukhumi region (okrug). But for Kutaisi Military Governor there were two districts in the okrug – Abkhazia (probably, historical territory of the Abkhazia principality) and Murzakani (probably, historical territory of Murzakani).

It is important, that Kutaisi Military Governor had involuntarily slipped in speaking the truth when producing statistics in his report, dated September 2, 1900. It is realized from the archival data, that the

Governor recognizes the reality in this letter. The following phrase of the report is as such – "by Georgians, primary by Megrels" i.e. Governor knew, that Megreli is the same Georgian. For the second time the Governor indicates correctly the priests national composition in the Sukhumi region (okrug): "As of today from 80 priests 4 are Russians in Sukhumi region (2 of them work in Sukhumi), 2 Abkhazs, 10 Greeks, and the rest 64 – Georgians (Megrels)" [2, 104].

So, positions of Russia in Abkhazia were gradually strengthened and Tsarist Russia implemented the plan of the whole Caucasus capture successively. Tsarist Russia tried to make Georgia integral part of the Empire, which would stipulate colonization of the country. Empire gave the leading importance to the border territories, among which Abkhazia had the leading duty.

Tsarist Russia tried to deliver Abkhazs from Georgians and to implement the idea of Russian Abkhazia" creation. Anti-Georgian disposition was artificially instilled among Abkhazs imperial-colonialist policy of Russia was fully revealed just in this part of Georgia. Abkhazia found itself under imperial principle pressure "disconnect and rule over" and Tsarist Russia policy started working with full sharpness to oppose different parts of Georgia, to remove Abkhazia from Georgia and to dissociate local population historically cultural-religiously.

Russia never adapted to Georgian ethnic prevail at the territory, which was very important for it and all the more, their opposition to defense own country and people. It was necessary to create conditions to carry out Russian colonization and they fought with all the methods. To create conditions implied first of all prohibition of everything Georgian and who would dare to defense Georgians, to punish them.

The abovementioned facts are the obvious expression of Russian colonial policy in Abkhazia, Abkhaz and Georgian population pursuit and settlement of the place by Russians. It is evident, that Russia tried to assimilate in the imperial space.

## References

[1] B. Khorava, „abkhaz's Muhajirity in 1867", Publishing House „Artanuji", Tbilisi, 2004

[2] B. Khorava, "ethnic and Demographic Processes in Abkhazia in the 19<sup>th</sup> - 20<sup>th</sup> Centuries", see: <http://7days.ge/index2.php?newsid=9618>; 28. 07. 2011

[3] Maisuradze G., Russian Colonization in Abkhazia, [http://expertclub.ge/portal/cnid\\_5891/alias\\_Expertclub/lang\\_ka-GE/tabid\\_2546/default.aspx](http://expertclub.ge/portal/cnid_5891/alias_Expertclub/lang_ka-GE/tabid_2546/default.aspx)

[4] PLLP – archive edition of the Georgian Ministry of Internal Affairs, Special Issue, 2009, #6

[5] PLLP – archive edition of the Georgian Ministry of Internal Affairs, 04. 10. 2009, #2

[6] P. Charaia, landownership, newspaper „Kvali”, 1897, #13

# Turkish Foreign Policy towards Balkans

İsa Erbaş

European University, Tirana, Albania  
[isaerbas@gmail.com](mailto:isaerbas@gmail.com)

## Abstract

*This study examines the Turkish foreign policy towards the Balkans. The purpose of this study is to enlighten the Turkish foreign policy towards the Balkan regions, which has been misunderstood recently. This research tries to find answers for these questions, within the Balkan scope: Turkish foreign policy in the 21<sup>st</sup> century, what has changed in Turkish foreign policy since 1990s?*

*Firstly, this study uses a historical narrative in order to establish a clear and meaningful theoretical approach for the Turkish foreign policies during the 20<sup>th</sup> Century. This study also analyzes the 'new Turkish foreign policy' towards the Balkan countries in the 21<sup>st</sup> century to observe whether any changes have taken place. Secondly, the study analyzes the tools of foreign policy and their contributions to the decision making process of Turkish foreign policy. Thirdly, this study analyzes various discussions about 'new Ottomanisms' of the Turkish foreign policy. Finally, the study concludes its findings and results with discussions and further suggestions. The paper uses content analysis in this part within the frame work of the qualitative and quantitative method. The respondents have quite diverse backgrounds which is very important to have a wider perspective. During the whole research and after the completion of the research, the researcher should abide by the ethical code of The Economic and Social Research Council (ESRC). The SPSS 16, and the Nvivo10 has been used to find and analyze the collected data.*

**Key Words:** *Turkish foreign policy, Balkans, cultural and historical relations, views, identities and interest.*

## 1. Introduction

In the political science and international relations, in order to understand the foreign policy we need to investigate and examine situations in a more appropriate and exact ways and to be able to evaluate

and approach realities. We should look at the foreign policy through different views, including economic, social, state identities, national interests, cultural, historical and psychological factors.

We need to focus on all the internal and external factors so we can analyze the issues. Apart from these, we have to concentrate on ideals and material interests. The Turkish foreign policy includes the historical, cultural and economic ties with Balkan regions. It is worth saying that the Turkish

foreign policy has always followed and preserved peaceful relations with Balkan countries.

The beginning of the Turkish foreign policy started during the period of Ataturk. Ataturk wanted Turkey to reach the level of modern civilization, which was only meant European civilization. During Ataturk's period the Turkish foreign policy united with the idea 'Peace at home, peace in the world' that was the motto of the Turkish foreign policy. Ataturk's state identity was concerned with state security, related to this security Turkey ensures a delicate balance which is maintained between cold rational calculations of power.

Due to its geographical and cultural positions in the international system it is believed that Turkey should interact and develop its relations with all countries especially with its neighbors. So in order to strengthen the relations with its neighbors, Turkey needs to develop its economy.

After the cold war some politicians, academicians strongly supported to follow the former policy. Contrary to this support, others insisted on following more active foreign policy and they went on saying that such policy should be in accordance with Turkey's size and strength since it was an important country in the region.

During the international developments, Turkish foreign policy was criticized for Neo-Ottomanism because of its passive character. The criticisms particularly appeared during international crisis and wars.

Neo-Ottomanists underlined that the new international order represented Turkey's significant

historical opportunities ranging from the Balkans to Central Asia. It was said that Turkey followed unimportant and inefficient policies towards the Balkans until that time. So, some political analysts were saying that Turkey was no longer bound to the current ideology. It was time for a more active foreign policy.

It seems that there is a kind of misunderstanding in Turkish foreign policy especially since Davutoğlu became the Foreign Secretary of Turkey. This study also tries to clear this misunderstanding and provide evidence about his policy and aims and objectives concerning foreign policy. His initiative was called a 'Zero Problem with neighbouring countries, and other foreign policies that need to be discussed and evaluated.

Due to the some historical and economic ties with the regions Turkey is concerned and worried about the instability in these regions. That is why, it is necessary for Turkey to build closer relationship with the Balkan countries in order to show its significance to the West. These countries are very important for Turkey in international arena, thus Turkey should try to help these regions to preserve security, peace, and stability. Any crisis and conflicts in these regions influence Turkey. That is why; external factors are affecting the changes in the Turkish foreign policy more than internal factors.

In 1999, conflicts started between Kosovo and Serbs. During those conflicts Turkey supported Kosovo. This study has analysed the Turkish foreign policy towards Balkans in general, particularly in Albania. Why Albania is important for the Turkish foreign policy? The reason is that, Albania, occupies better positions in terms of democratic and economic transition with its neighbours. Furthermore, there is a large Albanian speaking ethnic community living in Turkey. Therefore, the relationship between Albania and Turkey could be seen an example for other Balkan countries.

## **2. Factors behind the Foreign Policy**

It is known that domestic issues can shape foreign policy. Foreign policy also shapes leaders positions in power. So desires of leaders to stay in power can drive foreign policy (DeRouen, 2010, p.6). DeRouen goes on also claiming that "domestic politics, economic conditions, and public opinion are among the most important domestic factors that shape foreign policy decision making" (DeRouen, 2010, p.129).

According to Bull:

Firstly, they may enter into relations with political groups in other states; business enterprises, trade unions, political parties, professional associations, churches, all have their being partly within the transnational. Secondly, they may enter into relations with foreign states, as when a multinational corporation enters into an agreement with a host government, political groups engage in a protest outside a foreign embassy, or revolutionary groups in one country assist their co-ideologists in another to overthrow the government. Thirdly, they may enter into direct relations with an international organization (Bull, 2002, p.267).

These factors all affect nations. For instance, foreign policy decisions have very important consequences for nations, their allies, and rival countries. Even the decisions can affect the survivability of leaders in power (DeRouen, 2010, p.25). Some authors say the purpose is economy. Some say national interest and some say stability and peace. Even some say, the leaders, who are in power, make sure to strengthen their power. Drezner explains so clearly the purpose of foreign policy. He says "foreign policy leaders conceive of a national interest defined as maximizing their welfare and the security of that welfare. To further their interests, states will usually act to increase their own income and wealth" (Drezner, 1999, pp. 28-29).

## **3. Turkish Foreign Policy**

In such an environment, developments show us that international legitimacy, economic interdependence, respect for human rights, pursuing a sustainable environmental policy and harmony between people belonging to different religious and ethnic origins stand as the most important tools to build lasting peace, stability and prosperity. In other words, Turkey does not only develop its bilateral and regional relations in its close neighborhood, but seeks to create a positive synergy on a much wider scale and thus aims at contributing to global peace, stability and security. Turkey is aware of the necessity to foster the linkages between political stability, economic welfare and cultural harmony in order to attain sustainable global peace (Affairs R. O., Synopsis of the Turkish Foreign Policy).

Turkey's new foreign policy with the AKP reflects the equally fluid nature of the "multi-centric" world, defined by rapid power transitions. The aim of Turkey's new foreign policy is to make Turkey have a good position on the national, regional, and global levels in the first decade of the 21st century by manifesting itself in the rise of the AKP and domestic

economy, regional shifts, and global power transitions (Muzalevsky, 2012).

Economic growth and new political stability of Turkey since 1983, led the government to set up new foreign policies, which enabled Turkey to improve its relations with neighbors and states in the region alike. For this reason, "Ankara is highly interested in the Balkans and it has been so since 1989" (Rüma, 2010).

#### **4. Purpose of the Turkish Foreign Policy towards Balkans**

Turkish foreign policy is discussed by politicians and academicians in the Balkan regions. Some academicians claim that Turkey builds backbone of its foreign policy regarding its past. This discussion emphasizes the significance of cultural, historical, economic and religious past of Turkey. The politicians and academicians argue that Turkey ought to increase its influence in the Balkan regions. Turkey is believed to use the chance to become global power by developing its relations with these Balkan regions. Scholars claim that Turkey should not have any ideological orientations in these regions.

During the post-Cold war era, Turkey has been rediscovering its neighbors and trying to capitalize on its geo-political position in three distinct, yet interlocking regions. This process of re-discovery has been proceeding at an increasingly faster pace during the AKP era. Furthermore, there are solid economic reasons for a pro-active foreign policy strategy. Turkey has clearly been responding to the changing global context which involves a diversification of economic relations and the opening of new markets, especially at a time when Europe is faced with deep stagnation and the global economic axis has clearly been shifting in the eastern direction with the global financial crisis. (Ziya Onis M. K., 2011, Vol. 13 No.1).

The key objective of Turkish foreign policy according to the minister of Turkish foreign policy Davutoglu is:

The key objective of Turkish foreign policy has been to contribute to peace, stability and prosperity in the world. By the same token, we spare no effort to develop our relations with our neighborhood and beyond. As demonstrated by the recent increase in the initiatives Turkish foreign policy has embarked upon, especially in the adjacent regions and beyond, we are deploying every possible effort to encourage the consolidation of democracy as well as the settlement of disputes, which directly or indirectly concern Turkey (Davutoglu, 2010).

There are millions of Turks live in the Balkan regions that have Albanian ancestry and relatives. Apart from that, there is a Turkish minority live in the Balkan regions particularly in Kosovo. For these reasons Turkey wants to strengthen its influence on the domestic affairs of the regions (Abazi, April 2008, No.11).

One of the principles is to develop relations with the neighboring regions and beyond. So Turkey's regional influence extends to the Balkans. Turkey played an active role in the Balkans, especially, when there were crises in Kosovo and Bosnia-Herzegovina (Davutoglu, Turkey's Foreign Policy Vision: An Assessment of 2007, 2008, Vol. 10 / No. 1). It is very obvious that, Turkey's foreign policy's agenda is not to find conflicts with its neighbors, but its agenda is to promote interstate cooperation (Ziya Onis M. K., 2011, Vol. 13 No.1). Turkey tries to cooperate with all its neighboring countries.

In 2007, Davutoglu emphasizes the importance of maintaining stability and peace in the Balkan regions and he goes further: "we have to provide every opportunity in order to help our brothers in these regions" (Çelebi, 2007).

The Turkish president Apdullah Gül visited Serbia with many politicians and deputies. It showed that the Turkish foreign policy is very important for the Balkan regions. During the visit the president of Serbia claimed that during his 7 years presidency he has not hosted so many guests and he has never been with so many deputations before. During the meeting the president of Serbia Tadiç:

"We have been friends with dear Mr. Apdullah Gül. As a result of this long friendship Turkey and Serbia has become a strategic partner in the Balkan regions. We cannot think the Balkan regions without Turkey. As long as Turkey considers Serbia as an important partner in the Balkan, we can maintain stability and peace in the Balkan regions" (Bal, 2009). Apdullah Gül responds to the president Tadiç: "We suggest the ethnic and religious groups, as residents of these countries. Belong to the country and you need to work for the stability and peace for the country where you live. As a result, you can be like a bridge between two countries where you live and which one you have historical and religious ties" (Bal, 2009).

FEBA (Federation of Balkan American Associations) cooperates with TUSCON in order to enable the entrepreneurs from Turkey and the entrepreneurs who are originally from the Balkan countries. With the cooperation of FEDA (Fairfield Economic Development Association) and TUSCON associations, the entrepreneurs of Turkey, Bosnia,



Macedonia, Montenegro, Albania and Bulgaria gathered together in New York. The president of Turkey Abdullah Gül also was present in that meeting. Mr. Gül underlined the memberships of these countries of the EU and NATO. He claimed that the membership will bring stability and peace to the regions (Basyurt, 2010). Turkey uses the roads of these countries such as: Bulgaria, Serbia, Montenegro, Croatia, Slovenia, Greece, and Romania. If there are any problems regarding to security and instability Turkey can have difficulties in importing and exporting. So peace and stability in Balkan regions is very important for Turkey in order to have commerce and trade with European countries.

The former president of Montenegro Milo Djukanovic claims that Turkey's Enterprise in the Balkans helps to maintain stability and peace. The experienced former president considers Turkey as a friendly ally, and he invites the entrepreneurs to Montenegro. He sees Turkey's associations as an opportunity for the development of the Balkan countries. He states that Turkey-Montenegro social cooperation is very valuable and the leaders of both countries often come together (Yanatma, 2012). Türbedar claims that, various attempts have been made to explain the new dimensions of the Turkish foreign policy approach towards Balkans. The mainstream account argues that Turkey is eager to strengthen its position in the Balkans, so that it could improve its status on the global scene. (Türbedar, 2011). As it has been mentioned above there is no ideology in the Turkish foreign policy, the aim is only to increase the relations among these regions.

Turkey has played a very important role in preserving stability and peace in Albania, Kosovo, Bosnia Herzegovina and Serbia. Turkey is like an insurance of Balkan regions. In 1995 Turkey signed an agreement with Albania which was under Serbian threat. The agreement was about providing training for the Albanian army. For this training 100 million dollars were spent. In addition, The Pasha Liman base, which was spent 10 billion dollars, was reconstructed by 250 Turkish military engineers and signed a bilateral agreement by Turkey under the Turkish Navy which has the right to use it. As a result, the Adriatic Sea has become a sea base for the NATO and its allies (Turkiye gazetesi, 2003).

We can ask such a question. Why Balkan countries are important for Turkey? We can discuss the importance for different reasons. These countries are very important for trade, culture and politics. Firstly, the countries are very important for the geographic positions. That is not a coincidence that the two world

wars emerged in these regions. It is also very important for Turkey, because these countries serve as a bridge between EU and Turkey, and beyond these reasons the Balkan countries are neighbors of Turkey. Secondly, there is the same culture that was for 600 years. More importantly there are 25 million Balkan people that live in Turkey. There are also 1.5 million Turkish people that live in the Balkan countries. Even our relatives live in the Balkan countries. For example, there are 60 thousand Turkish people live in Kosovo and 80 thousand Turkish people live in Macedonia (Basyurt, 2001). Thirdly, there is a big advantage for the trade. There are about 70 million people live in the Balkan countries. That means it is a new market area for Turkey. There are about hundreds of Balkan associations in Turkey. These associations serve as a bridge between Balkan countries (Sait, 2006). Apart from the history of poor political relations and the gravitational pull of external markets, low levels of integration had economic roots too (Bechev, 2011, p.26).

Rüma claims:

What seems new in Turkish foreign policy towards the Balkans is the increasing importance of economic relations in Turkish foreign policy. In this sense, Turkish foreign policy is becoming more tied to the liberal understanding of international politics, which prioritizes the role of enhanced economic relations, and departs from its conventional roots in the realist /conservative school, which exclusively emphasizes political-security relations (Rüma, 2010).

"There is a clear need to pursue a proactive diplomacy with the aim of strengthening prosperity, stability and security in a neighborhood which spans the Balkans" (Davutoglu, 2010). "Any instability that emerges in the region may have political, economic and cultural ramifications on Turkey. For this reason, having peace and stability in the Balkans is among Turkish foreign policy's top priorities" (Türbedar, 2011). Turkey has always supported the Balkan countries. Turkey has always been a part of the larger international presence in the Balkans (Rüma, 2010).

Davutoglu claims:

Turkey enjoys multiple regional identities and thus has the capability as well as the responsibility to follow an integrated and multidimensional foreign policy. The unique combination of our history and geography brings with it a sense of responsibility. To contribute actively towards conflict resolution and international peace and security in all these areas is a call of duty arising from the depths of a multidimensional history for Turkey (Davutoglu, 2010).

As we have seen that all politicians and scholars give positive messages towards the relations between Turkey and the Balkan countries. For example, the prime minister of Montenegro Igor Luksić, “It is Turkey, which understands the Balkan countries well” stated when he visited Turkey. There are various ethnicity and religious groups that live in the Balkan countries. The prime minister also stated that, for both countries it is important to give such a message to peoples that live together in harmony and that is important for stability and peace for the Balkan countries. The Prime Minister Luksić went further that they were happy that Turkey helped and supported Montenegro during NATO and EU process and he invited the Turkish businessmen to Montenegro for the investment (Zaman Gazetesi, 2012).

According to Adam:

Turkey has become an active and visible player in world politics. The key of Turkey’s success in foreign policy lies in its ability to take full advantage of unique opportunities and deal with specific threats posed by its strategic location at the intersection of Europe, Asia and Africa, and its historic and cultural ties with the Balkans, the Middle East, and the Caucasus (Adam, 2012).

In the web page of Republic of Turkey Minister of Foreign Affairs the Relations with the Balkan Region is claimed as following:

The Balkans is a priority for Turkey not only from the political, economical and geographical perspectives, but also due to its historical, cultural and human ties with the region. Being itself a Balkan country, Turkey attaches great importance to its bilateral relations with the Balkan countries and maintains good relations with all of them. Our bilateral relations with these countries are based on the principles of respect for independence, sovereignty and territorial integrity and non-intervention into internal affairs and further developed on the basis of our historical ties and the principle of good neighborliness (Affairs M. O.). The long term national interests have maintained Turkey to play a stabilizing role as a regional power. Žarko Petrovic argues that “the success of Turkey’s Balkan vector is beneficial also for the internal dynamics in Turkey and the everlasting struggle between the Kemalists and the AKP. Foreign policy is important for Turkish voters” (Žarko Petrovic, 2011).

Muzalevsky claims:

In the Balkans, Turkey has improved ties with Greece and Bulgaria but the Aegean Sea and Cyprus issues still complicate the relationship. Yet Turkey has boosted its presence in the states of the former

Yugoslavia, where predominantly Muslim Bosnia now serves as a focal point of its activism. Ankara has also contributed to peacekeeping missions and mediation in disputes involving Slovenia, Croatia, Serbia, and Bosnia-Herzegovina. By integrating itself with the Balkans, it has sought to expand its influence and affirm its importance for the EU. Yet, doing business in the region, once dominated by the Ottoman Empire, remains a challenge for Ankara. (Muzalevsky, 2012).

## **5. Background of the Balkan Countries and their Relations with Turkey**

Approximately 70 percent of the Balkans is covered by mountains. The name “Balkan” derives from a colloquial Turkish word which means a forested mountain (Hupchick, 2002, p.2). The word Balkan has different meanings within the late nineteenth and early twentieth-century Ottoman context. The term Balkan means mountain or chain of mountains or mountainous (Boyar, 2007, p.30).

Turkey is also aware of the fact that if it is not active in preserving peace in Balkans, the door is closed to its European Union. Because of these concerns, “Turkey has sought to broaden its ties elsewhere, especially with those areas and countries where it has long-standing historical and cultural ties” (Dag, 2011, p. 7). It is argued that the Balkan countries such as, Albania, Bosnia Herzegovina, Montenegro, Serbia, Macedonia sooner or later will become members of the European Union. These countries are the last bridge Between Turkey and European Union (Cagaptay, 2008).

Turks of Balkan origin in Turkey, particularly of Albanian origin, have supported the resistance of Albanians in Kosovo since the 1980s and they had put pressure on Turkey during the Kosovo conflict (Eroglu, 2005, p. 59). For this reason, Turkey has become a more active actor in peacekeeping operations and humanitarian interventions in the Balkans. (Dag, 2011, p. 30) Since 2000 there has been a big increase among the Balkan people that consider Turkey as a friendly country.

Muzalevsky claims:

Turkey has emerged to play an active role in the Balkans after the end of the Cold War. But the gravitational pull between the two has been there for ages, cemented by politics, economics, and culture (Muzalevsky, 2012).

These statements clearly indicate the main pillars of Turkish foreign policy towards Balkans. Turkey has the desire to see the Balkans as an area of peace and security rather than conflicts. Preserving stability and

peace was always important in the Balkans for Turkey's security. Especially after the collapse of the communist regime, the importance of Balkan countries has widely increased. It is well known that the Balkans geographically connect Turkey to Europe. Turkey's strong historical, social and cultural ties with the Balkan people have always been an essential impact in its relations with the Balkan regions. As a result Turkish foreign policy makers have pursued a peaceful approach with all the Balkan countries.

#### **6. Misunderstood Policies towards the Balkans**

Therefore, these developments and similar trends towards Balkan countries in general, particularly Albania will go further. For example, over the last two years, many Albanian TV screens have begun to show Turkish soap operas which have great impacts on Albanian society. One describes this as 'Turkey returns to the Balkans, nearly 100 years after the Ottoman Empire was forced to leave the region and the scene of history' (Tartari(2), 2012). The Ottoman has not returned back to Balkans, only Turkey is in Balkans with its exports and goods including soap operas. I have been living in Albania since 2003; I have not seen any signs regarding New Ottomanism. The Albanian Prime Minister Berisha said 'the Turkish investments in Albania increased nine times starting from 2005, but this could have been 19 times and this is an objective for the future' (Tartari, 2012). The discussion on Neo-Ottomanism seems groundless, for there is neither a demand for this type of outreach by the Turks /Muslims in the Balkans or by Turkish society, nor a concrete base for the implementation of such a policy (Rüma, 2010). It is quite clear whether Turkish foreign policy towards Balkans is 'new Ottoman' or not. This is a highly debated topic and will be debated more in the future. The reason is that Turkey has become more stable politically and economically growing country. These developments give Turkey a unique position in the region that might be perceived as a kind of threat to other interested parties in the region. They know that public diplomacy is very important to increase international gain. For this reason, some use the term 'New Ottoman' in order to create public fear against Turkey which is not Ottoman in anyway.

#### **7. Views of Albanian People about the Turkish Foreign Policy**

As it is stated:

Main tenets of Turkish foreign policy towards Albania were almost identical to Turkey's overall

Balkan policy. Main objective of Turkish Balkan policy was to endure stability and peace in the region. Bearing this main objective in mind, Turkey developed its bilateral relations with Albania immediately after the end of Albanian isolationist policies following the death of Enver Hoxha<sup>71</sup>. Turkey, until the mid 1990s, rapidly increased its political, military and economic ties with Albania (Sülkü, 2010, p. 1).

One thing is for certain - this relationship has grown closer since 1990. Turkey has used various ways to enhance this relationship including economic aid, supporting social and cultural programmes by The Turkish International Cooperation and Development Agency (TIKA), training police officers and establishing schools. Further, in order to understand Turkish foreign policy towards Albania more broadly, one needs to read what has been written on the homepage of Turkey's Ministry of Foreign Affairs, which is stated that Turkey considers Albania a strategically important country for the establishment of enduring peace and stability in the Balkans and supports its integration with Euro-Atlantic institutions, which, it believes, will strengthen Albania's internal stability Turkey is also supporting Albania, in its efforts at bilateral and multilateral level, for developing its diplomatic relations and international effectiveness. Cooperation in the field of defence constitutes a comprehensive dimension of Turkish-Albanian bilateral relations. Teams assigned by the Turkish Land, Naval and Air Forces have been training Albanian Armed Forces and supporting them in logistics and modernization aspects, while Albanian soldiers assigned to Afghanistan within NATO framework are serving their mandate within the Turkish troops deployed in this area (Republic of Turkey Ministry of Foreign Affairs, 2012).

It is well known that Turkey sent peace troops in peacekeeping operations to Albania and Kosovo and improved its political and economic relations with all Balkan states. Consequently, the Balkan countries welcome Turkey's efforts for its regional peace and stability. As I have stated before Albania offers a big advantageous investment opportunities and chances for the Turkish entrepreneurs, because it has strategic doors that open to European, Balkan and also Mediterranean countries. There are more than 60 small and big firms and institutions in Albania that create and provide job opportunities for the Albanian people. These firms and institutions have been working in Albania for many years.

---

<sup>71</sup>He was a leader and founder of the communist party of Albania from 1941 till 1985.

**Survey**

This survey took about 7 months' started in December, 2012 and finished in June, 2013. I made this survey with 512 people in different Albanian cities mainly: Tirana, Shkoder, Kaveje, Kruje, Lushnije and Durres. The survey questions about foreign policy were not easy to answer. I tried to make survey with people, particularly, who were studying in the universities or who graduated from the universities. The survey questions were completed by different group of people such as: teachers, doctors, academicians, politicians, lawyers, businessmen, economists, statesmen and also some other profession groups. The main goal about this survey was to find out the Albanian people's perception and thoughts about the relations between Turkey and Albania and also the Turkish foreign policy towards Albania.

The gender average of this survey 52.02 % is female and 47.08 % is male. The education percentage of these respondents was secondary education is 26.1% and university education was 73.9 %. This survey was conducted face to face interview with different age groups starting from 18 to 60. Each survey took about 10 minutes. I asked the respondents 7 survey questions regarding Albanian –Turkey relations.

Figure 1. Which of the following countries is the closest ally to Albania? (Frequency)

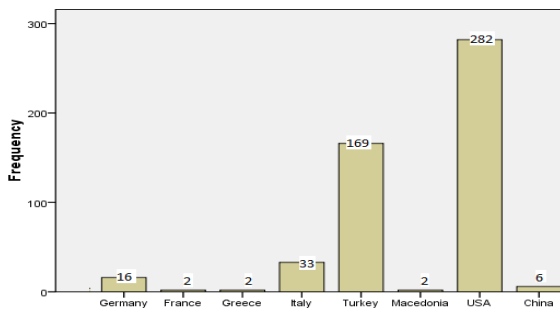
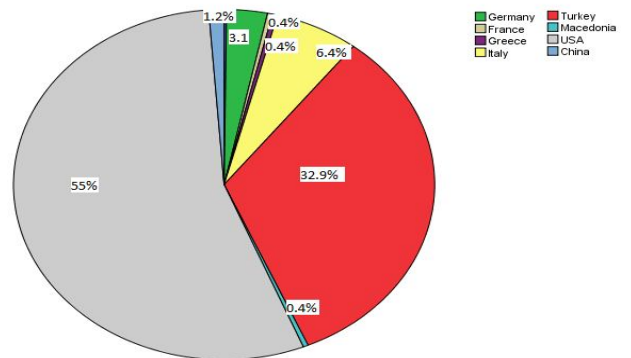


Figure 2. Which of the following countries is the closest ally to Albania? (Percent)



It is shown above that majority of the respondents, 55 percent or 182 out of 512; consider the USA as the closest ally to Albania. According to the chart Turkey is considered as the second close ally to Albania with 32.9 percent or 169 out of 512 respondents.

Figure 3. Which of the following countries do you think is the friendliest towards Albania? (Frequency)

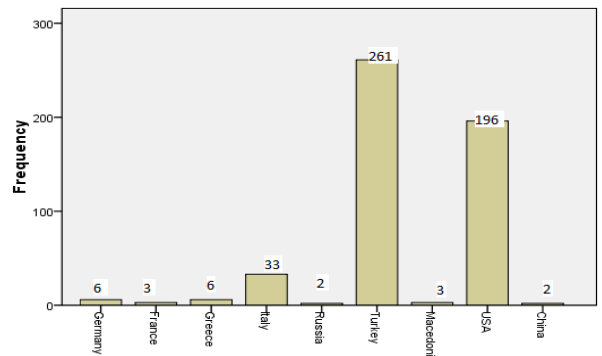
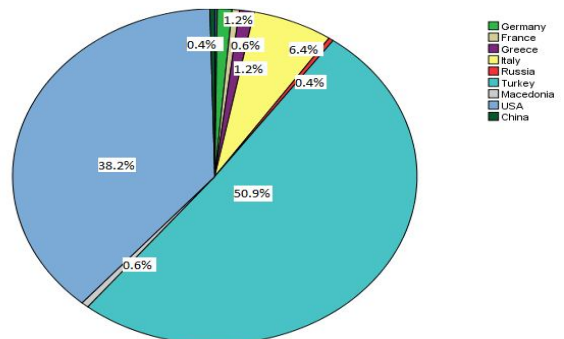


Figure 4. Which of the following countries do you think is the friendliest towards Albania? (Percent)



According to the respondents, 50.9 percent or 261 out of 512, consider Turkey as the friendliest state

towards Albania. The respondents, 38.2 percent or 196 out of 309, also consider the USA as the second friendly state towards Albania.

Figure 5. Which of the following countries has the greatest influence on Albanian Foreign Policy? (Frequency)

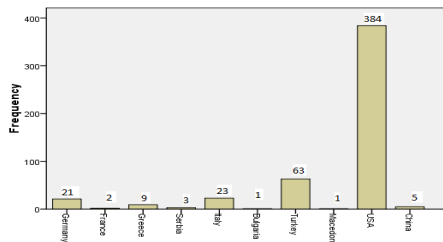
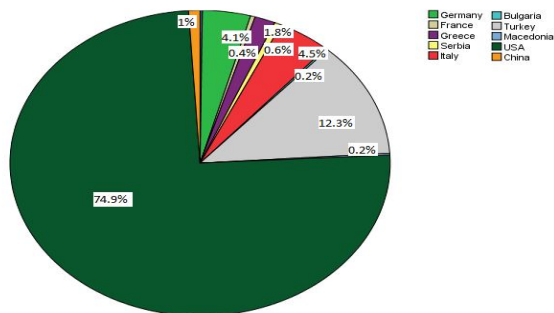


Figure 6. Which of the following countries has the greatest influence on Albanian Foreign Policy? (Percent)



According to the respondents, 74.9 percent or 384 out of 512, consider the U.S.A which has the most influence on Albanian Foreign Policy. The respondents, 12.3 percent or 63 out of 512, consider Turkey as a second state which has more influence on Albanian Foreign Policy.

Figure 7. Do you think that Turkey needs to improve its foreign policy towards Albania? (Frequency)

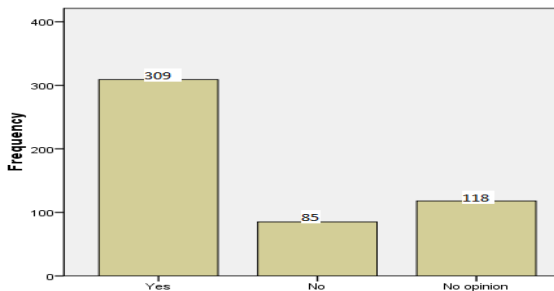
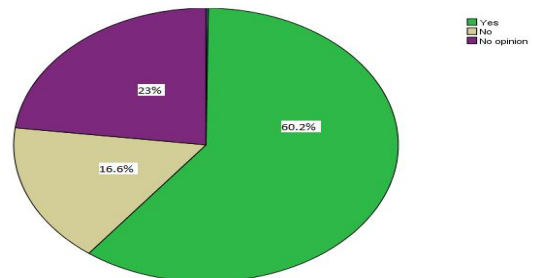


Figure 8. Do you think that Turkey needs to improve its foreign Policy towards Albania? (Percent)



According to the respondents, 62.2 percent or 309 out of 512, think that Turkey needs to improve its foreign Policy towards Albania.

Figure 9. What is the most important aim of Turkey's foreign policy towards Albania? (Frequency)

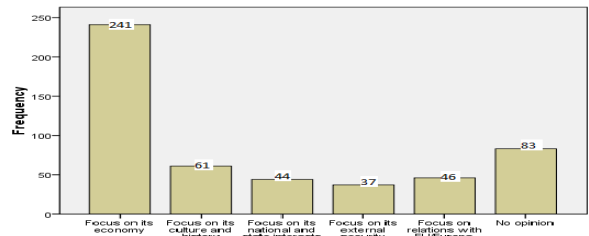
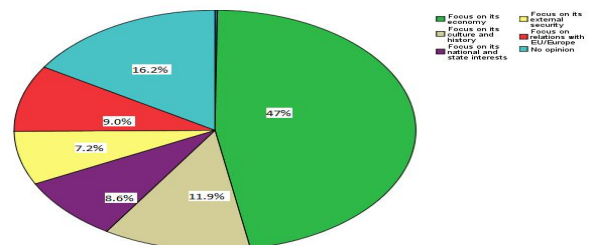


Figure 10. What is the most important aim of Turkey's foreign policy towards Albania? (Percent)



According to the respondents, 47 percent or 241 out of 512, think that the most important aim of Turkey's foreign policy towards Albania is to focus on its economy.

Figure 11. How important is the image of Turkey concerning the successful conduct of foreign policy towards Albania? (Frequency)

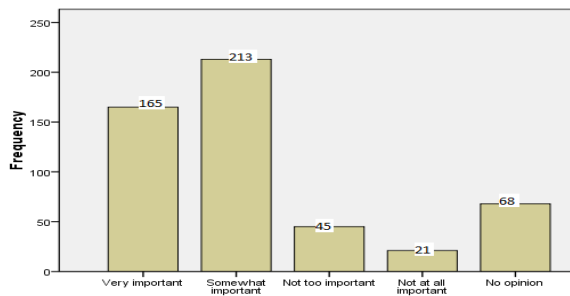
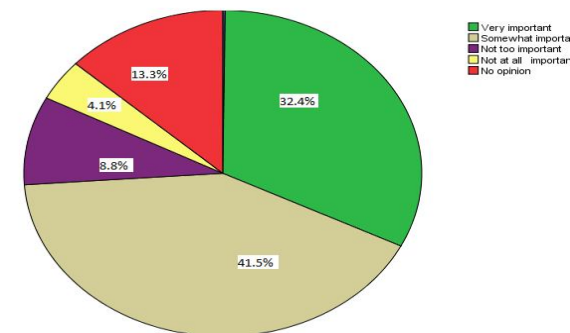


Figure 12. How important is the image of Turkey concerning the successful conduct of foreign policy towards Albania? (Percent)



According to the respondents, 41.5 percent or 213 out of 512 think that the image of Turkey concerning the successful conduct of foreign policy towards Albania is somewhat important, while 32.4 percent or 165 out of 512 think that the image of Turkey concerning the successful conduct of foreign policy towards Albania is very important.

Figure 13. What do you think about the relations between Turkey and Albania in future? (Frequency)

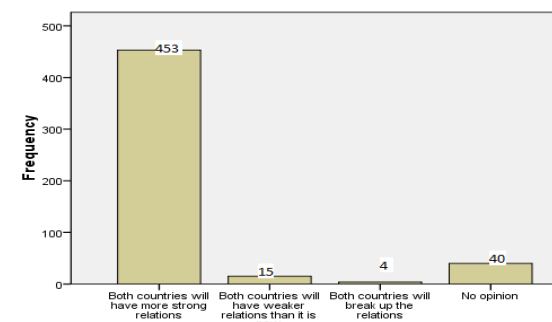
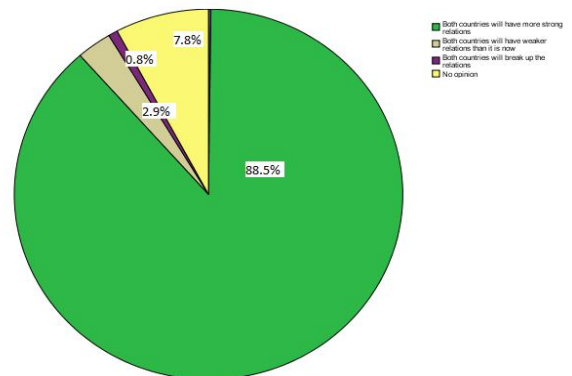


Figure 14. What do you think about the relations between Turkey and Albania in future?



According to the respondents, 88.5 percent or 453 out of 512, state that Albania and Turkey will have more strong relations in future.

#### Interview

In addition to the survey I conducted interviews with well known Albanian scholars regarding the Turkish foreign policy towards Albania. One of them is Prof. Dr. Ferit Duka, who is well known and successful Albanian history professor. I would like to state in this study what he stated during the interview:

I.E. Why Albania is important for the Turkish foreign policy? What do you think about that?

F.D. Turkey is one of Albania's main partners and a great country in the Balkans with which Albania historically had good relations. Although Albania was an isolated country and its relations with the world were very faint, but with Turkey its relationship has always been special and also close. I want to emphasize the fact that for the Albanians and for Albania, Turkey is a very important country from the point of view of historical relationship, stretching from the period of the Ottomans, and also from the standpoint of common interests in the Balkans or within European context. In my opinion the Turkish foreign policy towards Albania and Albanians has become more and more active during the years. The relations between Albania and Turkey have expanded and considering the period of interest, I can say that since 2000 there has been a new dimension in the Albanian-Turkish relations. The first point is the collapse of communism and the establishment of a democratic system in Albania and the opening of Albania to the world. The relations with Turkey have widened and enriched during this process. In both the Albanian and Turkish sides, there has been an increase in the consciousness towards the importance of the history which affects these relationships. Another important fact regarding the interest of Turkish policy in the Balkans and Albania are all the geopolitical and strategic issues which were

opened after the independence of Kosovo. The new reality that was created in the Balkans with the independence of Kosovo certainly increased the interest of Turkey both in the region and towards the Albanian factor in the Balkan. The historical relations and the common geostrategic interests in the Balkans and beyond have led to a new dimension of the relations, aiming to assist Albania which came out of the communist regime with many problems in every aspect. This is why there has been a development of the economic investments that Turkey has made in Albania. The Turkish foreign policy after 2000 has always shown interest to help Albania as I mentioned not only with economical investment presence but also with a wider presence in educational institutions which were founded during these times. There has been an increase in schools spread throughout the territory of Albania which are giving a great contribution to the education of a large part of the Albanian youth. The performance of these schools has been extremely good and they have become an example to follow, in order to take the education system in Albania into higher and higher levels. I emphasized that the presence of Turkey in education and economy is evident, especially since 2000. With all the presence of the Turkish capital and educational institutions here that is an aid for Albania. We need the Turkish investments in Albania even more present, especially in sectors that Turkey can give very precious assistance.

I.E. What are the priorities of Turkish foreign policy towards Albania?

F.D. I think that from the perspective of Turkish political interests in the Balkans, Albania is a special place. Albania is a country in the west Balkan which has been part of the western ties of the Ottoman Empire and it still remains a key strategic region, Albania is the western gate towards the Balkans. Secondly, Turkey is aware that there has been a long time of living together. The two countries have had a long term cooperation in history so that the Turkish political circles are aware that Albania remains a country with which Turkey can have a very good relationship and partnership, probably because of religious, cultural beliefs etc . Although a small country, given the role of the Albanian factor in the Balkans, Turkish policy is interested in having good relations with the Albanians in general, but especially with two countries that are the main voice of the Albanians in the region, Albania and Kosovo. There is also a large Albanian community in Turkey which is certainly well integrated. It is a community with an identity which they have carried from their mother country. Today as I am aware this community is a powerful voice in Turkey which has numerous

businesses. This community has a considerable role in the state and in the civil society around Turkey and I think that the presence of so many Albanians in Turkey is another cause in the Turkish foreign policy in Albania. These communities strengthen the bridges of friendship between our states.

I.E. Could you comment on the contributions that Turkey offered to Albania on the basis of its foreign policy towards this country especially since 1990s?

F.D. Turkey undoubtedly has played and continues to play an important role towards Albania. Turkey has been and remains a powerful voice when it comes to promoting Albania, Kosovo and the interests of the Albanians. I think that Turkey is a strong supporting voice, in support of Albanians, in support of Kosovo's freedom, in support of the interests of new state of Kosovo. Albania has a great interest in the progress of the state of Kosovo, so by supporting Kosovo, Turkey is supporting Albania too. To illustrate this is the assistance which was provided to Albania in its admission to NATO from Turkey. As far as I know turkey has played an important role not only in terms of the contribution to the growth in performance in the Albanian army so that it was worthy of admission into NATO but Turkey also gave political support to Albania to become a part of NATO. I believe that Albania will not forget this easily.

I.E. How Turkey is seen and what kind of image it has in Albania? What are the reflections of Turkey's foreign policy in this country?

F.D. This is a very interesting question, because today there could certainly be doubts about Turkey's image, especially when it comes to its foreign policy positions in the Balkans and Albania. You know some Turkish statesmen and the scholars of international relations, that today are in important state ranks or in the direction of Turkish foreign policy have developed and promoted certain views about the role of geopolitics in the strategy of the Turkish state in the present time with regard to strengthening the position of the today's Turkey's international relations and especially within the Balkan regions and especially middle east. Of course they are thesis from the viewpoint of political interests which aim to strengthen the international position of Turkey even more. Of course when it comes to the Turkish relations with Albania, there have been debates about Turkey's image in connection with its claim "to revive or recreate the image of the Ottoman Empire". The involvement of Turkey in the issues of Balkan, especially Albania, is sometimes misunderstood. It is sometimes misinterpreted as the desire to recreate the Ottoman Empire that is to take under control the policies of the



regions which once were part of the Ottoman Empire. I have been involved myself in these debates and I have emphasized that the relations of Albania with Turkey are a very important factor and I don't think that the Turkish republic would delude itself by thinking that it could recreate the Ottoman Empire. I am optimistic for the Albanian - Turkish relationship. Both countries have fundamental interests to strengthen friendship, to strengthen cooperation and to walk side by side towards progress. I am optimistic also based on the history of Albanian - Turkey relations. I think that Turkey can help strengthen Albania's economy. I'm also optimistic because they are two countries of NATO. This is a new dimension of the potential in favor of strengthening of these relations. Also I believe that the interest that both countries have in the Balkan, causes the strengthening of friendship and collaboration (Duka, 2013).

## 8. Conclusion

Turkey's foreign policy towards Balkans in general is not unique. In other words, Turkey tries to implement its foreign policy; whereby 'multi-dimensionality envisages increase of influence in all of its neighbouring regions and improving its relations with all international actors, rather than just depending on relations with the European Union and the United States'. I have stated above that there are some factors behind the Turkish foreign policy towards the Balkan countries. Secondly, Turkey wants to increase economic relationships with its neighbouring countries including the Balkans. This is important because, in this global world, economic strength leads countries to a stronger position than a military one.

Thirdly, Turkey pays more attention to tools of foreign policies namely, cultural and economic perspective and 'political-strategic perspective, integrating to European values. In order to achieve all of this, Turkey needs also time and work with other countries and statesmen.

Finally, Turkey's foreign policy towards Balkan countries is exceptionally getting better. Hence, there is cooperation between these countries on diplomatic and political relations. More investors of Turkey are coming to these countries and trade between these countries is increasing.

## References

[1] Abazi, E. (April 2008, No.11). Kosovo Independence: An Albanian Perspective. SETA .

[2] Adam, L. B. (2012). Turkey' Foreign Policy in the AKP Era:Has there Been A Shift in the Axis? *Turkish Policy Quarterly, Volume 11 No 13* , 139-148.

[3] Affairs, M. o. (n.d.). Relations with the Balkan Region. Retrieved May 15, 2013, from Relations with the Balkan Region Rep. of Turkey Minister of Foreign Affairs: [www.mfa.gov.tr](http://www.mfa.gov.tr)

[4] Affairs, R. o. (n.d.). Synopsis of the Turkish Foreign Policy. Retrieved February12,2013, from [www.mfa.gov.tr](http://www.mfa.gov.tr): <http://www.mfa.gov.tr/synopsis-of-the-turkish-foreign-policy.en.mfa>

[5] Bal, İ. (2009, November 3). Balkan Açılımı: Karlofça`daTadiç-Gül Buluşması. Retrieved May 24, 2013, from Usak Stratejik Gündem: <http://www.usakgundem.com>.

[6] Basyurt, E. (2001, May 16). *Balkanlarda Turk Olmak Zor,Zaman*. Retrieved May 13, 2013, from Zaman.

[7] Boyar, E. (2007). *Ottomans, Turks and the Balkans*. London: Tauris Academic Studies .

[8] Bull, H. (2002). *The Anarchical Society*. New York: palgrave.

[9] Cagaptay, S. (2008, February 17). Avrupaya Yeni Kopru. Retrieved June 2, 2013, from Yeni Safak: <http://yenisafak.com.tr/yorum-haber/avrupaya-yeni-kopru-kosova>

[10] Çelebi, Y. (2007, April 1). *Tika Balkanları İhya Ettii* . Retrieved May 24, 2013, from Yeni Safak: <http://yenisafak.com.tr>

[11] Dag, İ. (2011). Political economy of Turkish Foreign Policy. *Insight Turkey* , 7.

[12] Davutoglu, A. (2008, Vol. 10 / No. 1 ). Turkey's Foreign Policy Vision:An Assessment of 2007. *Insight Turkey* , 77-96.

[13] Davutoglu, A. (2010). Turkish Foreign Policy and the UN in 2010. *Turkish Policy Quarterly* , pp.1-17.

[14] DeRouen, A. M. (2010). *Understanding Foreign Policy Decision Making*. Cambridge: Cambridge university press.

- [15] Drezner, D. W. (1999). *The Sanctions Paradox, Economic statecraft and international relations*. Cambridge: Cambridge university press.
- [16] Duka, F. (2013). Turkish Foreign Policy towards Albania. (I. Erbas, Interviewer)
- [17] Eroglu, Z. (2005, April). Turkish Foreign Policy Toward the Balkans in the Post Cold War Era. Turkey.
- [18] Fidan, H. (2013, March 29). *A work in progress: The new turkish Foreign Policy*. Retrieved May 27, 2013, from Middle East Policy council: <http://www.mepc.org/>
- [19] Hupchick, D. P. (2002). *The Balkans from Constantinople to Communism*. New York: Palgrave, Macmillian.
- [20] Muzalevsky, R. (2012, April). *Turkey's New Foreign Policy in the New World*. Retrieved May 27, 2013, from American Diplomacy: <http://www.unc.edu/>
- [21] Raxhimi, A. (2011, April 21). Davutoglu: 'I'm Not a Neo-Ottoman'. (Davutoglu, Interviewer) Balkan Fellowship.
- [22] Republic of Turkey Ministry of Foreign Affairs . (2012, October 5). Relations between Turkey and Albania . Retrieved from Republic of Turkey: Minister of Foreign Affairs: <http://www.mfa.gov.tr/relations-between-turkey-and-albania.en.mfa>
- [23] Rūma, İ. (2010). Turkish Foreign Policy Towards the Balkans: New Activism, New Ottomanism or/ So What? *Turkish Policy Quaterly* , pp.133-140, Volume 9, Number 4.
- [24] Sulku, M. (2010, February). *Thesis Submitted to the Middle East Tenhnical University*. Retrieved June 3, 2013, from Political Relations Bbetween Turkey and Albania in the Post: <http://etd.lib.metu.edu.tr>
- [25] Tartari A. (2012, October 07). Turkey in the Balkans, love, fear and soap operas!.. Retrieved from Balkan Space Analysis: <http://balkanspace.org/mat.php?lang=2&idm=206&idr=38>
- [26] Turbedar, E. (2011). Turkey's New Activism in the Western Balkans: Ambitions and Obstacles. *Insight Turkey Vol. 13 / No. 3 /* , 139-158.
- [27] Turkiye gazetesi. (2003, January 3). Retrieved June 15, 2013, from İste Gucumuz.
- [28] Zaman Gazetesi. (2012, March 17). Retrieved May 23, 2013, from Karadağ Başbakanı Igor Luksiç: Balkanlar'ı en iyi anlayan ülke Türkiye: <http://www.zaman.com.tr>
- [29] Žarko Petrovic, D. R. ( 2011). Turkish Interests and Involvement in the Western Balkans. *Insight Turkey Vol. 13 / No. 3* , pp. 159-172.
- [30] Ziya Onis, M. K. (2011, Vol. 13 No.1). Political Economy of Turkish Foreign Policy: Politics of Trade and Integration. *Insight Turkey* , pp. 1-61 .

**Law**

## **Reforming the Investment Regime: A Progressive Approach to Global Environmental Governance.**

Kalpana Murar  
[ikalplaw@hotmail.com](mailto:ikalplaw@hotmail.com)

### **I. Introduction**

World's natural resources have gained importance at political level leading to power struggles between larger economies, multinational corporations or MNCs, states and communities. National governments and international institutions like WTO shape the legal context in which these diverse interests of multifarious parties are taken care of through domestic legislation and international treaties.

Natural Resource exploitation is one of the foremost areas where foreign direct investments flow into developing nations. It is these investments that can have a irreversible impact on the environment in the host state leading to transboundary damage that can threaten world's food and water security. It is therefore, crucial to examine the international investment regime and find avenues to remedy the situation that remains unnoticed to those who are concerned more with economic growth than the environment.

International investment law poses many challenges to meeting development and environmental objectives of a nation. These challenges are to be resolved to render investment rules as pro-development that can work under equitable regulatory frameworks of the host state. With the volume of investment treaties executed by nations, it may seem impossible to regulate all activities of a single nation as per treaty obligations. There is no gainsaying that global governance of investments in agriculture and land use management is crucial to mitigating further damage to the environment.

The topics presented in the paper are, by themselves, subjects of many books and involve volumes of documentation. I have, therefore, with the

risk of repeating previously existing theories, attempted to highlight some of the issues that seemed relevant to the present context. The paper reiterates the need to revive the negotiations and discussions for a multilateral investment agreement at the WTO level and as an alternative impress upon nations the need for transparency to place before the public all investment agreements and licensing agreements on exploitation of natural resources for the purpose of monitoring and evaluating their global impacts.

The paper, further, discusses the importance of a mandate on technology transfer to developing nations by developed nations as envisaged under the UNFCCC and replicating the same under the investment regime. The need to regulate foreign direct investment (FDI) within extractive industries as a part of global governance of the environment is discussed in the light of recent increase in global investment flows. It further aims to discuss certain basic but important clauses under the international investment law and provide some insight into how they could protect investments in the event of serious and stringent environmental regulation by host states during the investment period.

and economies-in-transition, this paper puts forward a theory of creating a global repository of all agreements and treaties executed under international investment law by relying on the principles of Global Administrative law (GAL), an emerging field that governs international institutions. It involves global administrative procedures that guarantee transparency, accountability and democratic participation by all nations. This emerging discourse can help reform international administration that can enhance the implementation and compliance of global regulatory regimes like that of international investment law and international environmental law and integrating both areas of law to govern global commons by regulating both states and international institutions.

## **2. A Call for Reforms in Environmental Management**

Economies depend on natural resources and businesses, intrinsically linked to nature and its conservation are facing the brunt of climate change effects. A British government report claims that climate change is costing between 5 and 20 percent of the annual global gross domestic product while mitigation measures could cost only 1 percent of the GDP. This verity prompted a group of global investors representing trillions in assets under management publish an open letter on the November 20<sup>th</sup> 2012 to governments of the world's largest economies calling for a new dialogue on climate change policy to avert its calamitous economic impacts. The demand was for "clear, consistent, and predictable policies that encourage low carbon investment, knowledge sharing between governments on effective climate and clean energy policies, building on successful existing national and regional measures; stronger international agreements that send clear market signals about the future of climate policy and reductions in greenhouse gas emissions." The letter, inter alia, was prepared by the European Institutional Investors Group on Climate Change (IIGCC), the North American Investor Network on Climate Risk, and was supported by the UN-backed Principles for Responsible Investment Initiative (PRI). The regional climate change investor groups, further, announced the formation of the Global Investor Coalition on Climate Change (GIC) to represent the international investment community on climate change policy and investment issues at a global level working closely with international policy-making bodies, convinced in the belief that timely and strategic management of environmental challenges could protect their investments in a more enduring manner. According to GIC, "investors have a major role to play in directing capital towards climate change solutions such as clean energy, efficient technologies and resilient infrastructure". The group believes that investor engagement on the critical issue of climate change is an important step forward.

Climatologists, meanwhile, believe that steps initiated in the next 10-20 years can have a profound effect on the planet, preventing further deterioration of the environment and reducing disruptions to economic and social activities across the globe. Investors and business entities in developing nations are urged to recognize and respect environmental norms of both international and national laws in order to meet their development objectives in a sustainable manner. They

are expected to assess the social and environmental impact of their activities and be fully accountable for any negative consequences of their actions in the host states.

Some nations gain significant competitive edge through continuing to pollute with no imminent threat of sanctions for free riding on nations that make serious efforts to reduce transboundary damage while some states encourage practices that violate internationally accepted environmental norms and pay no penalties.

Despite years into its implementation, Kyoto Protocol, a multilateral treaty of the United Nations Framework Convention on Climate Change (UNFCCC), whose term ends in the year 2015, has been unsuccessful in its efforts to mitigate the effects of climate change as is demonstrated in the erratic weather conditions, onslaught of hurricanes, floods and tornadoes, fast melting glaciers and rising sea levels.

It is time for a future climate agreement or a multilateral treaty on investment (MAI) that can help develop low-carbon economies by lowering energy costs, improving energy efficiencies and pushing entities to conform to principles of sustainable development through effective management of natural resources for intergenerational equity. This is a difficult agenda for nations that depend on developed nations for investments in the form of financial and technical assistance, transfer of technology, know-how and technical expertise.

## **3. Reviewing the Global Treaty on Multilateral Investment**

International framework on investment is a vast, decentralized medley of bilateral investment treaties (BITs) and Regional Free Trade Agreements (RFTAs) with services and investment components, as found in Northern Atlantic Free Trade Agreement (NAFTA), each with different terminologies and agendas depending on the nature of investments and the regulatory regime of the host state. These agreements are invariably signed between two sovereign nations that position economic interests above environmental objectives of a host state. Presently, investment agreements are under-regulated instruments that merely protect investments and investors against expropriation granting increased access to natural resources for foreign investors who face very limited technical barriers. In the absence of effective institutional arrangements for development, delivery, deployment and diffusion of 'green technologies' to developing nations these investment agreements or

contracts merely protect the investors and their investments.

prescribe stringent monitoring and evaluation mechanisms to conduct reviews and improve the effectiveness of environmental regulatory regimes of all nations. The framework for investment can increase the scale of investments in developing nations using incentives in the form of carbon pricing, demand-side subsidies, feed-in tariffs and disincentives or taxes for fossil-fuel technologies and other polluting systems. Finally, the framework should strengthen financial institutions to identify bankable projects and promote 'green projects' that are aligned with international environmental laws. There has been a significant increase in investment contracts in the land and agricultural sectors where agribusinesses, sovereign wealth funds and government agencies have been acquiring long-term leasing rights over large tracts of land in developing nations without a regulatory regime that can enforce climate smart agricultural technology, control soil degradation and land use changes. Private sector invests in the agricultural industry for the amplified returns from increasing commodity prices. This trend coupled with weak enforcement mechanisms in host states has raised concerns over the displacement of small-scale landowners and the need to preserve subsistence farming. Innumerable BITs have been concluded by sovereign nations, with no mechanism to monitor the environmental impacts of the investments that follow an agreement and their spillover effect on global commons.

International investment law has to strike a balance between commitments made by states under the investment contracts and the actual implementation of environmental measures in the host state. Investment contracts take care of the interests of the host state under domestic laws remaining in force for a period of 10-20 years open for renegotiation at the request of one of the parties. Investment treaties impose obligations on its member state signatories under public international law and in case of withdrawal by one of the states these treaties guarantee 10-15 years of investment protection. These treaties provide for free repatriation of profits and funds, protection against less favorable treatment than the local investors (national treatment) and investors from third countries (most favored nation treatment), absolute standards of protection (fair and equitable treatment) as well as a promise of compensation in case of nationalization or expropriation that may be either indirect or regulatory expropriation.

Investment agreements, customarily, do not indorse severe investor obligations relating to human rights or environmentally. The technical standards and frameworks to regulate international trade and investment. Legal implications of investment treaties is very limited as affected communities have no proper access to justice owing to weak enforcement mechanisms under the domestic regime and absence of extra-territorial jurisdiction on transnational corporations which often operate from outside the territory of host states. Investment agreements cannot subscribe to rigid regulation of investors' activities or exhibit a lax attitude towards governance. International treaties are generic in their language and leave any interpretation of the provisions to arbitrators who decide the dispute based on general principles of international law. These are some of the initial points of debate in favor of a MAI.

Time is now imminent to rethink and negotiate a MAI that can hold investors liable for environmental and social impacts of their businesses. Some of the developing countries like South Africa and Tunisia have attempted to revise the existing investment treaty model to include the right to regulate in public interest.

International rules to regulate investors' environmental behavior call for 'generic standards' for products and processes that can be uniformly applied across all sectors in areas of environmental impact assessment, public participation, mitigation concepts, emission standards and sustainable practices. In many developing countries domestic laws are ill suited to guarantee sustainable management of natural resources or protect vulnerable communities and indigenous groups that depend on the reserves of natural resource for their sustenance.

International investment law framework provides strong and enforceable rights for foreign investors denoting a clear imbalance between domestic and international regulatory regimes. Environmental performance of any business can be improved through voluntary and regulatory approaches that decree usage of processes, which can prevent worst environmental practices and issue mechanisms to monitor, evaluate verify and report the implementation of international standards against voluntary commitments of host states. Home countries can improve environmental performances of investors by incentivizing 'best practices' of eco-labeling, developing energy efficient systems and encouraging research and development for green technologies. This two-way approach, effectively improves the overall environmental management of businesses both in the host state and in the home country.

A MAI could impose higher standards of environmental governance across all sectors in uniformity while pushing for much needed reforms in policy frameworks that sets up international standards for all investments in the host states. The MAI so conceived could balance the interests of the investors and that of the local communities just as it serves to protect all inward investments.

Criticisms against a MAI include the apprehension that transnational corporations (TNCs) that are signatories could wield more bargaining power over governments and adopt a flexible approach to corporate governance. MAI could specify transparent and predictable regulatory regime for foreign investors that can impose binding obligations, such as technology transfer and adherence to international environmental norms, at the time of investment and on the other side offer reasonable alternatives and compensation in the event of unforeseen but necessary changes in environmental norms. MAI can help investors by preventing risks due to inconsistent regulatory regimes and harmonizing environmental norms for all investments across all sectors amongst all nations. In all, it could be win-win situation for the investors and host states if a MAI was indeed formulated. United Nations Conference on Trade And Development (UNCTAD) recommended status quo on the international investment regime for fear of giving in to developed nations and the investors whose primary motive was to increase their profits.

#### **4. Mandating technology Transfer with the Investment Regime**

UNFCCC and the subsequent Kyoto Protocol mandate transfer technology by developed nations to developing countries on the basis that international cooperation is requisite to facilitate adoption of environmentally sound technologies (ESTs) for mitigating climate change effects and adaptation to its impacts. This decree is on the supposition that climate change can be countered by shifting to clean energy and adopting environmentally sound technologies (ESTs) for their systems and processes.

ESTs are critical to sustainable development and poverty alleviation and reduce the strain on the planet by contributing towards a low carbon economy. Despite overwhelming documentary evidence which points to the benefits of ESTs, steps to develop a universal framework to regulate technology transfer through global investments have not fructified.

Agenda 21, arrays out a number of descriptions that characterize ESTs, and is comprehensive plan of

action to be administered globally, nationally, and locally by organizations of the U.N. system, governments, and in every area in which human activity has an impact on the environment. Chapter 34 provides the following definition:

“Environmentally sound technologies protect the environment, are less polluting, use all resources in a more sustainable manner, recycle more of their wastes and products, and handle residual wastes in a more acceptable manner than the technologies for which they were substitutes.

Environmentally sound technologies in the context of pollution are “process and product technologies” that generate low or no waste, for the prevention of pollution. They also cover “end of the pipe” technologies for treatment of pollution after it has been generated.

Environmentally sound technologies are not just individual technologies, but total systems, which include know-how, procedures, goods and services, and equipment as well as organizational and managerial procedures. This implies that when discussing transfer of technologies, the human resource development and local capacity-building aspects of technology choices, including gender-relevant aspects, should also be addressed. Environmentally sound technologies should be compatible with nationally determined socio-economic, cultural and environmental priorities.”

At the second Conference of the Parties, held in 1996 in Geneva, the Parties adopted the following definition of EST for the purpose of technology transfer:

*“Practices and processes such as “soft” technologies, for example, capacity-building, information networks, training and research, as well as “hard” technologies, for example, equipment to control, reduce or prevent anthropogenic emissions of greenhouse gases (GHGs) in energy, transport, forestry, agriculture, and industry sector, to enhance removals by sinks, and to facilitate adaptation.”*

The above definition helps understand the importance of technology transfer in avoiding the lock-in effects of non-ESTs on developing countries and the necessity to shift to green technologies and carve a sustainable development path.

UNFCCC failed to set firm targets for technology transfer stipulating vague obligations concerning stabilization or reduction of greenhouse gases (GHG) emissions. Neither the UNFCCC nor the international environmental regime cut out clear tasks for the governments or the private sectors in the context of technology transfer. Technological innovation and



implementation of technology transfer includes transfer of know-how and related information and skills development. With private sector looking for new avenues for natural resource exploitation and developing countries aiming to attract inward investments, tweaking the international investment regime for the purpose of achieving some of the environmental objectives seems a plausible solution.

The international transfer of ESTs among nations is severely constrained by economic, social, and legal barriers that include the nonbinding provisions for technology transfers, fluid nature of obligations imposed on developed nations to treat technology transfers as an obligation under outward investments in developing nations, ineffective compliance or weak enforcement mechanisms in the domestic regimes of host nations. Weak or the complete lack of institutional capacity, political and regulatory barriers work as impediments to transfer of ESTs technologies to developing nations. Technology transfer requires both domestic and international efforts that can make nations work in a concerted fashion under an overarching legal regime.

Technology transfer takes a complex path at the international forum with many components and numerous parties that include governments, the private sector and international institutions requiring sustained efforts by both the developing and developed nations and an compliant techno-economic regime. IPCC defines the parameters for technology transfer as:

*“broad processes covering the flows of know-how, experience and equipment for mitigating and adapting to climate change amongst different stakeholders such as governments, private sector entities, financial institutions, and research/education institutions.... The broad and inclusive term “transfer encompasses diffusion of technologies and technology cooperation across and within countries. It covers the transfer of EST processes between developed countries, developing countries and countries with economies in transition. It comprises the process of learning to understand, utilize and replicate the technology, including the capacity to choose it and adapt it to local conditions and integrate it with indigenous technologies.”*

*Transfer of technology needs to be a part of any foreign investment as it is critical to promote sustainable development in developing nations. It requires the transfer of skills and know-how for operation and maintenance, knowledge and expertise for appropriate diffusion of technologies. For effective transfer of technology and utilization there must be absorption of the transferred technology alongside its*

*technical adaptation to local conditions and integration with existing technology.*

*Private sector, the major driver of innovation and diffusion of technologies in developing nations is justified in raising the pitch for a call to devise climate-friendly policy frameworks that can benefit both investors and host states. International coordination of regulations and harmonization of product standards are powerful tools to improve energy efficiencies, increase cost-effective techno-economic activities and incentivize innovation.*

Similarly, Carbon Management Technologies (CMT) or emission abatement technologies, including Carbon Capture and Storage (CCS), are crucial to stabilizing greenhouse gas emissions. CMTs are also part of ESTs requiring substantial amount of support and aid from both the governments and the private sector. International investment law may protect investors in CMT industries by predicating these technologies on effective utilization of economic resources, improvements to living standards, protection of the environment and a guarantee for stable regulatory regime for the investors. The regime can raise demands for direct subsidies or expect the state to assume a long-term liability in adopting CMTs. Incentives for promotion of CMTs can stimulate private investments in the upstream energy sector that entail protection from risks arising out of political, financial or regulatory instabilities. The strategic, political, and economic importance of CMTs and ESTs has been reiterated at several levels and international investment law can promote these technologies without placing any constraints in the environment policy space of host states.

Ultimately, the path of “business as usual” is risky and poses greater challenges in combating effects of climate change. Every business model needs to be energy efficient, environment friendly and supportive of poorer nations through dispensation of climate finance and technology transfer. Private sector or multinational companies hold the patents for most of the advanced green technologies given the fact that very little knowledge about ESTs is available in the public domain. Governments in the host countries and home countries should create an enabling environment by introducing policy measures that are conducive to transfer of ESTs.

Multilateral Environment Agreements (MEAs) provide for technology transfer on the principle of ‘common but differentiated responsibility’ that calls for protection of the environment at the national, regional, and global levels and assessment of each country’s contribution to transboundary damage and its

ability to manage the threats. MEAs espouse the cause of technology transfer to developing countries with a motive to prevent high-emission, unsustainable business practices that was conventional in developed countries. The fact remains that there is no universal framework for the transfer of EST under MEAs, with developed countries following different mechanisms under different conventions. MEAs do not prescribe binding rules for technology transfer and are generally restricted to a party's best efforts in transferring appropriate technology. "Accordingly, the provisions regarding the transfer of EST are regarded as soft law because they do not impose binding commitments on countries against which compliance can be assessed, and they rely on national measures for their implementation, leaving individual countries with considerable discretion." (Bosselman , 2006)

Private sector is in no way compelled into transfer of technology to developing nations under the current regime of international environmental law, forcing governments to take independent measures to facilitate the transfer of ESTs. Some of the suggestions to remove infirmities in the regime of multilateral environment agreements include tax reliefs and rebates on the income of domestic companies in developed countries for revenues generated from the export of ESTs to developing countries, financial assistance for research and development in the field of EST, lifting export restrictions and reducing import tariffs on ESTs.

Climate change effects are to be countered by assimilating environmental measures within the international trade and international investment regimes supplemented by efforts to break the financial, political and institutional barriers to international or foreign investments. The World Bank and International Energy Agency (IEA) have estimated that the scale of current domestic and foreign investments into developing nations is insufficient to meet the requirements of technology transfer and environmental objectives. Multinational businesses are important to the economic growth of developing nations and in the development, deployment, transfer and diffusion of technologies to developing countries despite the possibility of an inherent risk of increased transaction costs.

Augmenting global resources for research and improvisations on ESTs is a step forward in developing low carbon economies. Developed nations that hold patents for most of the ESTs are expected to give away such technologies at a minimum cost to those nations facing the brunt of climate change effects even without any real economic development, as seen in the fate of

climate refugees from the Least Developed Nations (LDCs) and Small Island Nations who are losing their habitats and livelihoods to climate change effects and global warming.

pressures to lower environmental standards and encounter resistance to deployment of ESTs that are both energy efficient and cost-effective. For an understanding the barriers to transfer of technology, a reproduction of the study conducted by the World Bank and Intergovernmental Panel on Climate Change (IPCC) can help remove these deficiencies in a future agreement that regulates both investments and technology transfer.

The World Bank commissioned a study on technology transfer in the year 2006, which highlighted some of the measures that governments could take to create a suitable investment climate for energy investment and adoption of new technologies. They include

- removal of broad-based energy subsidies and tariff barriers;
  - establishment of credible legal and regulatory frameworks; Creation of market-based approaches such as emission trading, energy service companies, energy performance contracts, and credit guarantees;
  - information dissemination regarding energy savings and clean energy options;
  - including environmental costs in the price of energy services;
  - strengthening intellectual property rights;
  - developing product standards; Making markets more transparent;
- The IPCC conducted a study on traditional barriers that prevent diffusion of green technologies in developing nations, and found that barriers surfaced at each stage of the process, varying only by sectoral and regional context. The barriers included:
- lack of information
  - political and Economic barriers such as lack of capital, high transaction costs, lack of full cost pricing, and trade and policy barriers;
  - lack of understanding of local needs;

- business limitations, such as risk aversion in financial institutions; and
- institutional limitations such as insufficient legal protection, and inadequate environmental codes and standards.

## 5. Regulating FDI In extractive Industries

Natural resources and ecosystems presently attract a lot of political attention owing to the recognition of their high value for survival of the planet, social welfare and national security. New scientific knowledge and technological developments, determine the time to promulgate changes in health and environmental standards of a nation.

There has been exponential growth in foreign investments and in particular, foreign direct investments (FDI). FDI is defined as ownership with some form of control of all or part of a business in another country. It is made to acquire a lasting interest in an enterprise operating in an economy other than that of an investor, the investor's purpose being to have an effective choice in the management of the enterprise (IMF, Balance of Payments Manual, 1977).

The protection of foreign investment is normally envisioned as an incentive to investment in pro-environment projects rather than a 'safeguard' against potential problems arising from it. (Vinales, Jorge E, 2012). According to a report prepared by the Multilateral Investment Guarantee Agency (MIGA, World Investment and Political Risk, Washington D.C., The World Bank, 2011) "foreign investors perceive regulatory change as the riskier contingency they face when investing in developing countries". This is a risk that cannot be avoided given the instabilities arising out of global warming and climate change and constant updates on new scientific knowledge that calls for a uniform change in regulatory regimes. A stable investment regime can be achieved if the nuances of the regime are worked out at the initial stage or at the time of making the investment and priming investors for unavoidable but necessary changes and exigencies in environmental management.

Transparency with regard to investor behavior and good corporate governance ensures host countries fair benefits from FDI, expressly, in resource extracting sectors. FDI has the capacity to raise domestic environmental standards by transfer of ESTs through joint ventures and usage of local resources in a sustainable manner. FDI has the propensity to support developing nations in their economic development

through import of foreign capital, technical know-how, and accretion of jobs that could raise the living standards among the population. The effects of FDI vary according to the type of investment made in the developing nation. It is contended that when FDI takes the form of a firm involved in mining operations, the investment could have a considerable impact on the environment than mere import of capital goods or mining equipment.

Investment agreements need to extend exceptional treatment to investments in natural resource exploitation through business practices that respect local community rights over the reserves of natural resources, and policy flexibility to maximize benefits to host countries. It is affirmed that stringent environmental standards do not necessarily increase the volume of investment flows but can increase the value of FDI and reduce negative externalities in the host country.

The Declaration for the Establishment of a New International Economic Order (NIEO), adopted by the United Nations General Assembly called for a restructuring of the international order toward greater equity for developing countries particularly in reference to a wide range of trade and financial issues. The Declaration was designed over a set of proposals for more equitable international economic cooperation, trade reforms, increased development assistance and reduced tariff barriers. In terms of technology, the Declaration acknowledges that "the benefits of technological progress are not shared equitably by all members of the international community," and highlights "the need for and possibility of significant (negotiation) that address the role and power of multinational corporations, "the international division of labor, world market access and supply, the transfer of technology, economic sovereignty and related financial flows." (Green and Singer, 1975:433-4) NIEO was expected to bring together nations committing themselves to protecting foreign investments through binding legal principles and within a single framework.

Many believe that FDI in natural resource sectors may not be economically beneficial to the host country and can encourage capital-intensive investments that can distort future development paths of a nation. This calls for a revamped investment regime that can lower the environmental impact of FDI, and strengthen host country regulatory regime.

Investors in mining and other extractive industries seek access to natural resources and choose their mining sites be contingent on availability of cheap labor or less stringent environmental standards or both. Many developing nations have relaxed existing

environmental norms that govern mining operations with the intention to attract foreign investments in the sector and keep them in a steady flow.

Increased economic activity in environmentally sensitive sectors is likely to cause more damage exacerbating existing distortions. Most often, environmental costs are not adequately internalized in any country. FDI has the propensity to stimulate high rate of economic activity that may not be matched by the existing regulatory regime of the host state, leading to irreversible damage within the natural resource sectors. Home countries too need to take greater responsibility in managing their investors by regulating their firms or corporations working in the host country.

Countries like Papua New Guinea and Indonesia permit mining operations under conditions that provide minimal or absolutely no environmental regulation over these activities. This laxity or complacency in regulating highly destructive mining industry confirms the existence of weak and corrupt government infrastructure and lack of oversight of decisions on management of natural resources. The immediate and direct impact of such insensitivity is evident in the large-scale destruction of the forests and international river ecosystems and large-scale human rights violations. Philippines has reported reduced fish yields due to pollution of their rivers from discharge of copper wastes, where the government looks the other way keeping in mind the competition for FDI within the minerals sector. With investment liberalization the competition for foreign investments is likely to intensify leading to utter disdain for the environment and conservation of natural resources.

Regulating extractive industries to prevent unsustainable practices is an onerous task for national governments especially if the impact is going to be sensed at a global level. The urgency for a collective and concerted action on this issue has been acknowledged by nations calling for a universal framework on international investments, a regime that elevates the purpose of conserving the global commons over ensuing economic profits. Nations are reluctant to take unilateral actions for fear of losing their competitive edge over other nations that can offer similar bouquet of natural resources to foreign investors. A competition for investment forces governments to lower their environmental standards well below socially optimal levels in the absence of a global regulatory body to monitor indiscriminate violations of international environmental norms. Increased FDI in developing nations tends to have an irreversible and long-term debilitating effect on the

environment that could undermine the efforts for sustainable development.

The option that can successfully restrain nations from abusing the environment is by manipulation of market forces through a MAI that dictates the manner in which investments are made and host countries are chosen, presents a level playing field. The multilateral agreements developed under the international investment regime, where the framework of reference is the 'environment' and not investments or trade can ultimately aid in optimum distribution of economic benefits and strengthen international codes of investor conduct.

## **6. Environmental Regulation of Foreign Investment**

Major reforms in the investment regime include promotion of sustainable development, emissions control and binding positions for transfer of technology to developing nations. The spate of increase in global investment flows compels stringent regulation of investments for transparency and accountability. The regime should support domestic regulatory efforts of governments that can match the scale of international economic activities.

A shift from 'minimum regulation' to 'binding minimum environmental standards' that can enhance global corporate behavior and upholding higher standards in environment protection and corporate governance promulgated through a multilateral agreement negotiated under the auspices of the WTO or an independent body created for the purpose of protecting natural resources of the world. This limitations posed by environmental law regime appears to be a major setback to achieving global environment protection objectives. Presently, the legal regime for environment protection does not provide for penalties for breaches or imposes sanctions on investor companies for unsustainable business practices.

Potential conflicts arise between general concepts of environmental law that include prevention and risk assessment third party participation in regulation and access to justice, predictability and stability, non-discrimination of similar actors, and property rights and the three vital provisions of fair and equitable treatment, national treatment and expropriation of the international investment law need to be resolved by integrating these principles under one framework.

Environmental regulation is a means to internalize the external environmental costs of investing firms' economic activities. The "pollution havens" theory states that developing nations undervalue their environment through lax or unenforced regulations,

attracting companies to shift their operations to such nations in order to take advantage of lower production costs, which is the “industrial flight” theory. As a contrast, some foreign companies in keeping with global corporate behavior and managerial ethics use better environmental management practices to raise the bar for environmental standards in a host country. This is considered as the “pollution halos” theory. Environmental damage results in increasing costs of a project for cleanup and reparation and mindless exploitation and depletion of natural resources.

Under international investment laws, host states need to maintain international standards in environmental management of ecosystems to supplement food and water security. Increased flows of trade and the investment aggravate the present trend of unsustainable practices in the exploitation of scarce natural resources. Investors and governments must accept the inevitable outcomes of diminishing economic benefits, and rising environmental and social costs in the natural resource sectors. Sustainable development requires policy measures that do not provide instant incentives for resource exploitation and resultant pollution, but support environmental governance in developing nations and good corporate behavior from investors. Liberalization of investments without appropriate checks and balance in areas of environment protection can result in irreversible negative impacts in the host country that includes, water scarcity, soil degradation and diminished food security.

International financial institutions that aid projects in developing nations have a responsibility to the environment and therefore conduct reviews of investments for their environmental impacts and accordingly reject or amend projects. These institutions attempt to regulate investments in the interest of public and the environment. Equator principles (EPs) is a “risk management framework, adopted by financial institutions for assessing and managing environmental and social risk in projects and is primarily intended to provide a minimum standard for due diligence to support responsible risk decision-making. The EP applies globally to all industry sectors and financial products that may be relevant to FDI. Financial institutions that endorse the principles commit themselves to environmental and social causes that include establishing indigenous rights, labor standards and consideration for local communities that may be affected through projects financed by their institutions. The EP has created a momentum in the right direction for development of responsible management practices that are environment-friendly.

The poor and marginalized are directly affected by environmental degradation. It is essential that investments in developing nations postulate solutions to poverty alleviation as part of their corporate social responsibility. Investment decisions in developing nations or economies in transition are to be analyzed with inputs from weaker sections of the society where the investments are likely to have an impact, making public participation and access to environmental justice, a part of the investment regime.

OECD Guidelines on Multinational Enterprises (MNEs) recommends that enterprises should, “within the framework of laws, regulations and administrative practices in the countries in which they operate, and in consideration of relevant international agreements, principles, objectives and standards, take due account of the need to protect the environment, public health and safety, and generally to conduct their activities in a manner contributing to the wider goal of sustainable development”. MNEs are expected to “maintain contingency plans for preventing, mitigating and controlling serious environmental and health damage from their operations, including accidents and emergencies, and mechanisms for immediate reporting to the competent authorities”.

They should “continually seek to improve corporate environmental performance, inter alia, by adoption of technologies and operating procedures in all parts of the enterprise that reflect standards concerning environmental performance in the best performing part of the enterprise; and research on ways of improving the environmental performance of the enterprise over the longer term”.

The Draft UN Code of Conduct for Transnational Corporations addressed conflicts that arose out of national sovereignty issues, social and cultural diversity, policy frameworks on environment and investments. If the Draft Code was adopted by participating nations, it could have served the prerequisites for a MAI that had the efficacy of regulating natural resources sector while meeting development objectives of nations.

The Code effectively mandated all TNCs to carry out their activities in accordance with national laws and regulations, establishing administrative practices and policies relating to the preservation of the environment of the countries in which they operate with due regard to relevant international standards. It further provided for TNCs to take steps to protect the environment, take steps to develop and apply adequate technologies and take remedial measures against any damage that may have ensued their business activities. The central importance of TNCs for the

global economy raises a fundamental question: How should TNCs be made accountable to the public good?

The Code, provided for TNCs:

*“to supply all information in respect of the products, processes and services they have introduced or propose to introduce in any country, characteristics of these products, processes and other activities including experimental uses and related aspects which may harm the environment and the measures and costs necessary to avoid or at least to mitigate their harmful effects,*

*“Prohibitions, restrictions, warnings and other public regulatory measures imposed in other countries on grounds of protection of the environment on these products, processes and services.”*

*“TNCs should be responsive to requests from Governments of the countries in which they operate and be prepared where appropriate to co-operate with international organizations in their efforts to develop and promote national and international standards for the protection of the environment”.*

TNCs are also expected to “disclose to the public in the countries in which they operate, by appropriate means of communication, clear, full and comprehensible information on the structure, policies and activities and operations of the transnational corporation as a whole.”

In the process of regulating foreign investments on environmental measures, it might be pertinent to assess the consistency of an investment scheme with environmental disciplines. A domestic environmental measure must be consistent with international investment or trade standards and derive its authority from international laws.

## **7. Investment Claims Against Environmental Measures**

The last decade witnessed substantial increase in the number of investment claims brought against the states against environmental measures that had domestic legal basis, but essentially dictated by prevailing standards under the international environmental law. Tribunals have attempted to determine the legal basis of an environmental measure by extricating states' compulsion to comply with international environmental norms from their inherent right to impose domestic laws on foreign investors. “Expropriatory environmental measures, no matter how laudable and beneficial to society as a whole - are, in this respect similar to any other expropriatory measures that a state may take in order to implement

its policies: where property is expropriated, even for environmental reasons.”

Four different types of disputes arise where environmental measures are alleged to conflict with fair and equitable treatment:

*a) environmental permits are denied or combined with constraints on arbitrary grounds or based on unjustifiable distinctions*

*b) environmental permits are unduly delayed by the authorities*

*c) environmental permits are revoked due to previous errors on the side of the actor or the authority; or*

*d) change in environmental regulation restricts future profitability of the investment.*

“The sole effects doctrine on the interpretation of indirect expropriation focuses on the economic burden the public measure imposes on the investor. If a measure has a substantial effect on the economic benefits or value, or on the control of the operations, and where this effect is lasting in time, there is a prima facie case that an indirect expropriation has occurred.” (Dolzer&Schreuer 2008,p.101). Under this doctrine, the “determining factor whether an indirect expropriation has occurred is solely the effect of governmental regulatory measure on the investment” (Kriebaum, 2007). In situations where investment tribunals apply the ‘sole effects’ doctrine in assessing claims for expropriation, they ignore the intent of the government or state in passing the environmental measure and pass an award on liability and damages based on the effect of such measures on the investors.

The doctrine of police powers focuses on and shields the public measure and distinguishes normal regulatory measures from compensable indirect expropriations. The doctrine defends any bona fide regulation within the limits of a police power and deems it as a legitimate exercise of police powers. Tribunal in Methanex Corporation v. United States held that “ But as a matter of general international law, a non-discriminatory regulation for a public purpose, which is enacted in accordance with due process and, which affects, inter alios, a foreign investor or investment is not deemed expropriatory and compensable unless specific commitments had been given by the regulating government to the then putative foreign investor contemplating investment that the government would refrain from such regulation”(Rowley, Reisman and Veeder, 2005). It was further enunciated that “ It is now established in international law that States are not liable to pay compensation to a foreign investor when, in the normal exercise of their regulatory powers, they adopt in a

non-discriminatory measure bona fide regulations that are aimed at the general welfare” (Watts, Fortier and Berhens, 2006).

The following text from US model BIT 2004, Annex B, para 4(b) substantiates the argument that general public measures on environmental or health protection are normally not indirect expropriation:

*(a) The determination of whether an action or series of actions by a Party, in a specific fact situation, constitutes an indirect expropriation, requires a case-by-case, fact-based inquiry that considers, among other factors:*

*(i) the economic impact of the government action, although the fact that an action or series of actions by a party has an adverse effect on the economic value of an investment, standing alone, does not establish that an indirect expropriation has occurred; (ii) the extent to which the government action interferes with distinct, reasonable investment-backed expectations; and*

*(iii) the character of the government action.*

(b) Except in rare circumstances, non-discriminatory regulatory actions by a Party that are designed and applied to protect legitimate public welfare objectives, such as public health, safety, and the environment, do not constitute indirect expropriations.

The complexity of expropriation lies in distinguishing reasonable regulatory changes that cannot be eschewed, but expects investors to adjust their operations appropriately within a given phase-out time, from public interest initiatives that may seem like indirect expropriations, which deserve to be compensated.

Initial spate of investment disputes filed under NAFTA revolved around investment claims filed against environment protection measures that presumably undermined investor rights. International arbitration makes an easy platform for investors to challenge environmental measures with the governing law being that of the treaty and not the law of the host state. A change in the terms of developing nations accepting international investments from developed nations should clinch sustainable development, energy conservation, research and development and poverty reduction and give less scope for claims based on environment related public measures.

Investment treaties need to advance primacies for quality over quantity of investments in developing nations and enabling legally binding obligations on the investors. Some of the obligations are compliance of minimum environment standards for environmental assessment and management, passage of

enforceable domestic legislation and contribution to economic and social development of the local communities.

The investment regime should deter investors from using investor-state arbitration to redress breaches of specific treaty-bound obligations. International arbitration on investment disputes lacks an appeal system or arbitral rules to respect precedents and most often arbitration tribunals arrive at different conclusions on the similar set of facts.

According to UNCTAD, about 390 known IIA disputes were taken up for arbitration by the end of 2010. (IIA Issues Note 1 (2011)). The number of disputes or the nature of disputes remain unclear and it is important that disputes on environmental regulation must be placed before the public for discussion and understanding and dissemination of valuable information on natural resource management, energy, treatment of hazardous wastes and water management, ruling out public participation, a critical ingredient of international environmental law. The principle is that the decisions of the tribunal and the award are made public only if the parties concur.

Environmental regulation that veers towards efficient and sustainable use of natural resources, ultimately, relates to social and economic development of not just the host state, but also states that may be affected by the actions of the state party, therefore contentious issues on natural resource management and environment protection have to be placed in the public domain for debates and valuable inputs from experts and the public.

Host states that accept investments through international investment treaties (IIAs) ought to conform to standards of national treatment, fair and equitable treatment, the umbrella clause or the promise to fulfill commitments made to investors. In the umbrella clause, the host state guarantees to ‘observe any obligation it may have entered into with regard to investment’. The purpose of the clause is to elevate some violations of investment contracts to that of a violation of the IIA, meaning to raise a contractual breach to that of a violation of public international law. Without an umbrella clause, a mere breach by the state party cannot be reckoned as state responsibility. The IIA umbrella clause converts breaches of contractual obligations into international liability for the state and includes obligations of a commercial nature for the host state in contracts regarding foreign investments.

CMT investments, for example, can be protected through the umbrella clauses by internationalizing what might otherwise be a simple breach of contract, which needs to be agitated before the domestic courts



of the host state. In a situation where the state decides to withdraw a subsidy for a CMT or refuses to honor a transfer of liability for carbon storage, the investor cannot raise an investment claim for expropriation based on the violation. Arbitral awards have opined that withdrawal of subsidies may not actually diminish the value of a CMT investment and cannot be deemed to be a violation of the national treatment standard unless it targets foreign investors 'ex facie or as a matter of practice'.

The major arguments in favor of investors using international forums to settle disputes against host states are factors that deter investors from resorting to domestic courts that may be wanting in efficiency and running the risk of facing injustice in the hands of host state courts. Investment arbitration is governed by international law but does not really provide for the intricacies of investments per se. The principal argument for enabling international arbitration in investment disputes is that many developing countries and economies in transition fail to provide investors with the necessary protection to their investments predominantly due to weak, nonexistent or biased legal institutions. According to international law the state responsibility for an internationally wrongful act is to cease the act, if it is continuing, provide full reparation in the form of restitution and compensation.

## **8. Reinforcing Natural Resources Agreement**

International petroleum agreements are good examples to discuss renegotiation, stabilization and adaptation clauses of the international investment law. Investors commit substantial large sums of money for a fairly long term in businesses that are considered high-risk, where risks could be either geological, commercial and political, expecting the project's fiscal and regulatory regime to remain stable during the duration of their investments. These clauses in investment agreements for natural resource exploitation provide requisite stability to the projects.

"Foreign investors use stabilization, renegotiation and adaptation clauses to freeze the legal situation in the host country at the time of concluding the contract, while renegotiation clauses aim to protect the foreign private party by making the contract flexible throughout its duration and permit any kind of mutation to the terms of the contract and restore the equilibrium of the transaction." These clauses underscore the flexibility of the contract that allows changes in the terms of the contract, which can ultimately reduce investor disputes and diminish

chances for state intervention in the workings of the project.

Government imposed regulation that upsets the financial returns and impacts the economics of a project, tends to destabilize the investment contract and therefore, investors turn to contractual clauses that preclude any changes to the regulatory regime without the consent of the investors. Stabilizations clauses are a requirement in investment agreements to restrain unilateral legislative interference by the state to either amend or abrogate the agreement. "When stabilization clauses develop a conflict with sovereignty issues of the host state, public interest dictates that the state modifies the terms of the contract to its singular advantage establishing the supremacy of legislative rule over previously negotiated contractual commitment that could undermine the legality of such clauses". Hence, it is not pragmatic to rely on the protection provided by the stabilization clause as the state can always take refuge in claiming that the regulatory or fiscal regime changes were legitimate exercise of their sovereign power over their natural resources.

In the exercise of its sovereign powers, a state is not considered to have breached the contract and its action is not considered to be illegal that can have the effect of creating international state responsibility. This aspect of the national sovereignty undermines the legal effect of stabilization clauses, although it can help determine the compensation to be awarded to the investors.

Renegotiation clauses tend to find a place in agreements for natural resource management. The Organization of Petroleum Exporting Countries (OPEC) in the 1960s caused a renegotiation of state contracts with oil companies operating in its member states that resulted in full ownership of most of the oil companies.

The major concern of the foreign investor is the uncertainty and sudden shift in environmental standards and regulations as awareness on prevention of pollution and mitigation measures increases. Despite the economic impacts resulting in increased costs of the projects, foreign investors are expected to comply with new standards and regulations by spending additional amounts of money. This change in circumstances could trigger a call for renegotiation of contracts to avoid termination and ensure the tenure of the agreement. The adaptation clause that provides for flexibility for a third party adaptation of the contract reduces confrontation and breaks the impasse. It has been contended that it is in the interest of the host state to have the contract modeled on a flexible and

amendable format to adapt the circumstances to both domestic and international scenarios. Renegotiation clauses offer protection against unilateral revocation or modification by the state.

The doctrine of *rebus sic stantibus*/change of circumstance is an accepted norm under international law, applicable even in the absence of 'change of circumstance' clause in the agreement itself as is found in the Vienna Convention of the Law of Treaties, 1969 under Article 62. "The legal effect of a fundamental change of circumstances under the treaty is that the disadvantaged party can request withdrawal or renegotiation of his treaty obligations", subject to Articles 26 and 65 of the Convention.

The ICJ in *Gabcikovo-Nagymaros* Project case observed that "a fundamental change of circumstances must have been unforeseen; the existence of circumstance at the time of the Treaty's conclusion must have constituted an essential basis of the parties to be bound by the Treaty. The tribunal further stated, "The negative and conditional wording of Article 62 of the Vienna Convention on the Law of Treaties is a clear indication, moreover, that the ability of Treaty relations requires that the plea of fundamental change of circumstances be applied only in exceptional circumstances". It is not clear whether there is a duty to renegotiate investment agreements under international law when entered into with governments and there has been a genuine and fundamental change of circumstances.

In the absence of a renegotiation clause, parties have, on many occasions relied on force majeure clause in the agreement or the hardship clause of international contract law. Force majeure and hardship clauses that are used to reduce any damage or costs that a party may face in the event of being forced to perform under the changed circumstances.

Hardship clause is used in situations where the contract performance is not impossible but rendered arduous due to external circumstances. This clause can be useful under circumstances where environmental emergencies arise and projects are either deferred to stopped midway due to such exigencies as found in sales contracts relating to natural resources and other international long-term contracts.

Professor Clive Schmitthoff defined the circumstances in which a hardship exists. An event is considered as hardship event if it has three elements: (1) it must have arisen beyond the control of the parties; (2) it must be of fundamental character; (3) it must be entirely unanticipated and unforeseeable. These clauses can help in renegotiation of some of the contractual terms in order to adapt the contractual

balance, which may have been upset by changed circumstances.

Trigger events to invoke renegotiation clause can be defined and devised according to the nature of industry that the investment contract is targeting. Dominant triggers for changes in environmental regulation are new scientific knowledge or the change in acceptance of an environmental problem. Regulatory changes occur throughout the system of environmental law ranging from intense regulation to changes in processes and production systems. Scholars have suggested a common method to reduce this regulatory uncertainty using phase-in periods for the reforms with private actors gaining time to tune their business activities accordingly. Ultimately, environmental regulation should balance the need for change with rules and predictability for all actors concerned varying only with political dimensions of each host state.

New restrictions may be imposed on investors when new knowledge about the impacts of the activity or the mode and means of environment protection mechanisms has changed. Denmark safeguards its operating permits for a period of eight years, after which time the supervisory or regulatory body issues new orders on safeguarding measures. In the interregnum, if new knowledge arises on harmful side effects of the activity, the government reserves its right to introduce new measures extending sufficient time for the investor to incorporate new regulatory regime in its operations. Uncertainty and unpredictability of regulatory changes are inherent in environmental law, yet, semblance of stability can be achieved through transparency in bringing in reforms that may be sparked due to unforeseen circumstances. This way, the reasonable and bonafide expectations of foreign investors are not thwarted.

Designing a triggering point for a renegotiation clause in an agreement does not have any prerequisites. Conditions and criteria to be met may vary before a renegotiation phase can commence. Some agreements link the trigger of renegotiation to the imposition of laws or regulations the implementation of which adversely affects the economic benefits of a project. Hardship clauses provide for a starting point for renegotiation in rare cases and under strict conditions. The renegotiation clause imposes a duty upon the parties to renegotiate their agreement once the conditions for invoking the clause are realized. Renegotiation clauses seem more enforceable when it requires the parties to consult each other and "make the necessary changes to ensure that the contract is restored to the same economics, which would have prevailed if the new law and/or regulation or

amendment had not been introduced.” This clause works with certain rules and one particular rule is that “the original equilibrium of the contract should be maintained and therefore neither party should be allowed to profit or forced to suffer a loss as a result of the renegotiation”.

International law does not explicitly recognize a duty to reach an agreement over a dispute and hence the fact that an agreement has not been reached is irrelevant to the liability issue. In the event of a failure on renegotiations, parties are required by virtue of the principle of *pacta sunt servanda* to fulfill their obligations as originally agreed. If the host state refuses to fulfill its contractual commitments, the state would be in breach of contract and the damages due for this breach would be calculated on the basis of the original contract terms.

El Chiati points out that renegotiation clauses are a manifestation of the autonomy of the will of the parties and as such are binding on the parties as long as they do not violate public order. The effectiveness of such clauses is to be strengthened through future judgments. The important feature of a hardship clause is the right to refer the question of any adjustment to an independent arbitrator to determine the issue as to whether, and if so to what extent, the contract price or other terms of the contract may be modified. Adjustment of the contract provides a means of resolving a dispute where the parties cannot negotiate their differences.

Professor Dr. Klaus Berger, (in *Renegotiation and Adaptation of International Investment Contracts: The Role of Contract Drafters and Arbitrators*), proposes that international investment contracts include a clause allowing the parties to renegotiate the terms of their contract if certain events take place. If they are unable to reach an agreement, Professor Berger advocates that the parties agree to permit an arbitral tribunal to modify the terms of the contract and restore the economic equilibrium assumed by the parties to the time when they concluded the agreement. Private parties involved in international transactions have rarely included these clauses in their contracts although they are useful when one of the parties controls the event that triggers renegotiation and adaptation. These clauses are particularly useful in international investment contracts between a private party and a government entity. It can protect a state's sovereign right to change laws and equally protect the private investor. The renegotiation and adaptation clauses leave a state's sovereignty intact and protect the investor against changes in the law governing the agreement.

Arbitral tribunal in AMINOIL case, ruled “general principles that ought to be observed in carrying out an obligation to negotiate – that is to say, good faith as properly to be understood as the following (1) sustained up-keep of the negotiations over a period appropriate to the circumstances; (2) awareness of the interests of the other party; and (3) a preserving quest for an acceptable compromise”. The tribunal further observed “failed negotiations can be regarded as a breach of contract and thus entail legal responsibility if such failure can be attributed to one of the parties”.

In 1978, the International Chamber of Commerce (ICC) promulgated rules for the adaptation of contracts. In 1994, it withdrew the rules because they were never used, preferring the principle of *pacta sunt servanda*. Downsides to the clauses include uncertainty, increase in transaction costs or a higher return on the investment, lack of clarity on the existence of a dispute in the event of a failure of the clause, lack of guidance to modify the terms of the contract, and the compulsion that trigger events need to originate from actions of the host government.

The UN Draft Code of Conduct for TNCs contains a provision according to which these corporations should engage in renegotiation even without a relevant contractual clause:

In the absence of contractual clauses providing for review of renegotiation, transnational corporations should respond positively to requests for review or renegotiation of contracts concluded with Governments or governmental agencies in circumstances marked by duress, or clear inequality between the parties, or where the conditions upon which such a contract was based have fundamentally changed, causing thereby unforeseen major distortions in the relations between the parties and thus rendering the contract unfair or oppressive to either of the parties.

Review or renegotiation of contracts in such situations should be undertaken in accordance with applicable legal principles. By devising a flexible contractual regime using the renegotiation clause, the host country's sovereignty remains intact but may be effective only if it is supplemented by an arbitration clause that opens avenues for third party adjustment of the contract when the parties are unable to reach a consensus.

The UNDRIT Principles of International Commercial Contracts also provide a framework in which renegotiation can occur and, if that fails, for a possible third party adaptation of the contract, in the event of a hardship. These principles permit both investors and host governments to modify their agreements in the event of unforeseen circumstances.

Scholars have suggested that if parties wish to include a renegotiation and adaptation clause, they should pay particular attention to three considerations: (1) the scope of events that trigger renegotiation, specifically whether the events must be unforeseen and beyond the parties control; (2) whether the applicable law or laws recognize the ability of an arbitrator to adapt the terms of a contract in the event that the parties are unable to reach an agreement through renegotiation; and (3) the criteria that the arbitral tribunal should use in adapting the contract.

Pactasuntservanda is the leading maxim of contract law generally has priority over changes in the surrounding economic conditions, which can be overcome only if the contract contains a renegotiation clause. UN Resolutions that founded the New International Economic Order (NIEO) in the 1960s have influenced the argument that without a specific contractual clause, international investment contracts include an inherent duty to renegotiate in light of changed circumstances. Under international contract law, it derives from the principle of good faith and the duty of the parties to cooperate based on it. (ICC Award No.6219 (1990))

Most OECD governments and many non-OECD governments provide investment guarantees and political risk insurance (PRI) designed for international investors in the incidence of sudden and precipitous hike in compliance costs due to changes in the regulatory regime. The World Bank's MIGA (Multilateral Investment Guarantee Fund) defines political risk as:

*“Political risks are associated with government actions which deny or restrict the right of an investor/owner i) to use or benefit from his/her assets; or ii) which reduce the value of the firm. Political risks include war, revolutions, government seizure of property and actions to restrict the movement of profits or other revenues from within a country.”*

Risks insured include 1) currency inconvertibility and transfer restrictions; 2) confiscation, expropriation, nationalization; 3) political violence; 4) default on obligations such as loans, arbitral claims, and contracts. PRI programs hold clients responsible for compliance with their contracts through self-monitoring and self-reporting. MIGA describes its environmental monitoring procedures as follows:

*“Compliance will be assured by the applicant's specific and continuing representations and warranties that measures to comply with environmental requirements will be taken and maintained throughout the term of the Contract of Guarantee.”*

Public PRI providers promote investments and environmental standards under the OECD Common Understanding and monitor observance of these standards, unlike private PRI providers who refrain from such promotion. International investment agreements are treaties between sovereign governments, public PRI are generally based on contracts linking public PRI agencies and private investors. OECD investment guarantees include and promote international standards on environment.

## 9. ReviewingnOECD Negotiations on Investment Treaty

International investment agreements delineate commitments on investment protection and depict how these commitments are to be integrated with public policy objectives. Environmental regulation has been a frequent source of investment disputes between investors and the host states. Host states contend that regulation in the context of public policy is exclusively their prerogative.

The Organization of Economic Co-operation and Development (OECD) conducted a survey with a sample of 1623 international investment agreements for use of references to environmental concerns in international investment agreements. The key findings of the study included:

a) language referring to environmental concerns is rare in BITs but common in non-BIT IIAs.

b) country practices regarding environmental language in treaties vary where 19 of the 49 countries covered in the study never use such language in their treaties.

c) presently, more than 50% of the treaties deal with environmental concerns.

According to the study, environmental language addresses seven distinct policy purposes, which include:

a) general language in preambles that establishes protection of the environment as a concern of the parties to the treaties.

b) reserving policy space for environmental regulation for the entire treaty;

c) reserving policy space for environmental regulation for specific subject matters.

d) some treaties contain provisions that preclude non-

discriminatory environmental regulation as a basis for claims of “indirect expropriation.”

e)

9 treaties contain provisions that discourage lowering of environmental standards for the purpose of attracting investment.

f)

environmental matters and investor-state dispute settlement.

g)

As few as 16 treaties contain provisions related to the recourse to environmental experts by arbitration tribunals. One treaty even excludes the environmental provisions as a basis for investor-state claims. A mere number of 20 treaties contain provisions that encourage strengthening of environmental regulation and cooperation.

The 1973 Basel Convention on the Control of Transboundary Movement of Hazardous Wastes and their Disposal, the 1992 Convention on Biological Diversity, and the 1992 UNFCCC are some of the significant environmental agreements that have successfully implemented environmental measures on a global scale. Predominantly, provisions in BITs have restricted themselves to implementing basic requirements of environment protection regime consciously stay away from updating the language of environmental concerns to the latest scientific knowledge. The Energy Charter Treaty (ECT), a multilateral investment agreement executed in the year 1994 contains explicit references to efficient exploration, production, conversion, storage, transport and distribution and use of energy and is singularly placed among MEAs. Some of the IIAs include clauses that seek to reserve environmental policy space to regulate. With so many different elucidations on environmental concerns within investment agreements and environmental agreements, the argument for a multilateral agreement on investment that voices out environmental concerns in a more explicit manner, especially with regard to natural resource management is reinforced.

In the year 1991, the OECD drafted a multilateral agreement on investment (Draft MAI) on the edifice of three factors which include the rapid growth in global investment flows, unilateral liberalization of national restrictions on foreign investments in both developing and developed states, and the miscellany of investments contracts and agreements at the international level. Given the mandate that agreement was to

*“provide for a broad multilateral agreement for international investment negotiations progress”.*

The Draft MAI aimed to liberalize restrictions imposed on investors by preventing member states from discriminating between foreign and domestic investors. It followed NAFTA provisions applying standards of national treatment and most-favored nation treatment to both the pre and post-admission of foreign investments. Adopting a ‘top-down model of liberalization’, the Draft MAI applied the concept to all economic sectors in the host state unless specifically exempted under the agreement by the contracting parties. It also replicated NAFTA in prohibiting performance requirements including technology transfer used by developing countries in their economic planning process. The MAI required host states to compensate investors in the event of expropriation of their investments and requiring member states to provide “fair and equitable treatment and full and constant protection and security” while ensuring a minimum standard of treatment “as required by international law”. While it did not provide for investment incentives and safeguard any new laws enacted to protect the environment, the MAI deemed them as a form of “expropriation”.

The OECD-MAI, apparently threatened legitimate national environmental regulation by preventing discrimination against foreign investors in order to protect the environment, allowing investors to challenge regulations that have the effect of facing discrimination by the government under the national treatment rules. Investors could also challenge governments for expropriation on the plea that their profits have been taken away through an environmental regulation.

The Draft MAI adopted an open and “asset-based” definition of “investment” that attempted to include various forms of capital flow without making a distinction between portfolio investments and FDI. Under OECD MAI, the term ‘investment’ was defined in terms of “every kind of asset owned or controlled, directly or indirectly, by an investor....” followed by a list that covered both equity-based and contractual assets. As was required, many expressed the need to include indirect investment, intellectual property, concessions, public debt and real estate within the purview of ‘investment’.

Developing countries are unlikely to accept coverage of short-term portfolio investments as part of the definition. There is no single definition of what constitutes foreign investment since it varies according to the object and purpose of different investment

instruments, which contain it (Juillard and Carreau). Definition of investments varied according to the BITs model that was being referred to making it difficult to mandate transfer of technology as part of investment. There is no single definition of 'investment' under international investment law that can, in an overarching manner, include transfer of technology or ESTs, capacity building, and "process and product technologies", allied research and development. "The absence of a traditional legal understanding of the term 'investment' however, was not seen as an obstacle to its use. Instead the advantage of the term was seen in its potentially wide scope and the flexibility arising from its openness" (Dolzer, Schureur, 2008). There is no single definition of what determines foreign direct investment. Investment agreements use a broad connotation to the term 'investment' including every kind of asset followed by a list of assets on the surmise that the term 'investment' is constantly evolving. The International Centre for the Settlement of Investment Disputes (ICSID) convention does not define the terms 'investor' and 'investment' despite acting as a repository of all bilateral investment treaties and conducting arbitration over investor disputes between states and the investors.

The term 'assets' could include both tangible and intangible assets that may need protection under the treaty. A definition that encompasses technology at its core can open up discussions on financial incentives for investors who transfer technology at reasonable cost and become eligible for subsidies to conduct research and development activities within the host state.

The interest protected against expropriation by the investment treaties is concomitant to the definition of the term investments in the treaty. It is not only land and other tangible assets that may be expropriated but also intangible assets including intellectual property. The Iran-US claims tribunal, *Amoco International Finance Corp v. Iran Award*, held that expropriation might extend to any right that can be the object of a commercial transaction.

Schreuer&Kriebaum, 2007, in an analysis of the concept of property in human rights law and international investment law stated, 'When determining the existence of an investment, tribunals have emphasized on the ownership of specific assets and not the combination of rights that were necessary for the economic activity at issue.

Initially, the MAI did not provide for setting up environmental standards, but after intervention by lobbyists including NGOs, an additional clause on environment was included in the preamble. It was

proposed to include a "no lowering of standards" clause, to ensure that it was not used as an incentive for inward investments.

"The fear for a 'race to the bottom', meaning that states compete to attract foreign investment by lowering the environmental standards applied to the investment, has motivated the inclusion of so-called non-lowering standards clauses". Although there is not much empirical support to this claim, in the developing country context, the mining and energy sectors could gain significantly if environmental standards are compromised to attract investments.

The Draft MAI was never adopted or ratified owing to resistance from developing countries and NGOs on the assertion that it did not provide for environment protection as an obligation by investors and host states. It was concluded that the failure of the MAI negotiations was on account of a perception that the agreement would pose a threat to national sovereignty and that it was conceived purely as an investor and investment protection economic instrument, which clearly displayed an imbalance between investor rights and responsibilities. With increasing depletion of resources and in the absence of accountability both on the part of investors and host states, there was a need to introduce stringent and binding norms for investors on technology transfer, environment protection and resource management. The major aspect that led to its abandonment was the datum that developing countries were mere observers in drafting the OECD MAI and were never a part of the negotiations. As host countries for foreign investments, developing countries have resisted all attempts to endorse investment norms for environment protection at the multilateral level.

The new investment regime needed to deal with economic and social issues providing a minimum protection for the environment and aid in the development of least developed countries (LDCs). In all, the investment regime should establish a fine balance between investment liberalization and legitimate social regulation by public institutions.

## **10. Leveraging WTO for a Dynamic Investment Regime**

International Investment has been a topic of intense debate and discussion for a future WTO negotiating agenda. NAFTA Chapter 11 had set the agenda with high standards for investment liberalization, investment protection, and dispute settlement. Investment was dealt with by trade related agreements in a fragmented manner and continues to remain a collage of international rules on foreign investment.

The major defect in present form of regulation of foreign investment relates to the time after the investment is complete. The investor is treated to a full range of regulatory measures by the host state, thus, discriminating between foreign and domestic investors.

Many believe that WTO could be the right forum to achieve a multilateral treaty aimed at liberalizing FDI even as it protects public interest issues relating to labor, environment and culture. WTO's influence stems from the advantage of providing "institutional anchorage", including an already functioning set of rules and dispute settlement mechanisms and is considered one of the successful international organizations in the world. The treaty could gain from the special and differential treatment accorded by WTO to developing nations, which form an integral part of all negotiations within the organization.

WTO influences technology transfer and global competition through the provisions of Trade Related Aspects of Intellectual Property Rights (TRIPs), Trade Related Investment Measures (TRIMs), Subsidies and Countervailing Measures (SCMs) and the Information Technology Agreement. Under WTO rules, no country should be prevented from taking environmental measures for protection of human health, animal or plant life, or health, at the levels it considers appropriate. Developing countries are increasingly involved in world trade and with the liberalization of their economy they are seen opening up large sectors to global competition. WTO helps these nations to receive direct investment and technology transfer from developed nations. Developing countries need effective implementation of technology transfer and developed countries are obliged to provide incentives for those institutions and investments, which aid in transfer of technology to the LDCs.

WTO's Integrated Framework, based on the 'mutual beneficiary' approach, provides a supportive and constructive leverage for technology transfer to developing countries. Multinational Corporations (MNCs) influence global trade and technology transfer to developing nations as the main technology suppliers. A cogent system of technology transfer through MNCs necessitates the development of a framework that displays the capacity to establish a 'mutual' network of developmental, techno-logical, managerial and economic benefits for both parties involved. Post-WTO, governments and MNCs are forced to develop a more balanced approach to their global policies that renders all countries as equal partners and stakeholders in their enterprises. At this stage of the discussion, it is necessary to reiterate the requirement for a multilateral framework on investment that secures a stable and

predictable condition for long-term cross-border investment and/or FDI wielding considerable influence for technology transfer.

WTO-covered agreements do accommodate environmental concerns through the General Exceptions of the GATT. The GATT environmental exceptions have appeared in some BITs, reflecting the possibility of adapting certain legal principles that exist in the trade context could be incorporated into investment regime. In the present day scenario, these provisions could be enhanced and made stringent and explicit. The WTO Agreement on Sanitary and Phytosanitary Measures or the SPS Agreement, has set certain standards for regulation in the context of international trade. The same may be emulated for environmental standards for investment activities, permitting regulatory flexibility and measures against protectionism or any form of discrimination. Provisions for mandatory environmental impact assessment and performance requirements of foreign investments can deter developing nations from lowering environmental standards for the purpose of increasing investments. International regulation of investments could only bring benefits to developing nations and economies in transition by improving the working conditions, ensuring environmental compliances and increasing economic benefits. Incentives for better emission control systems, energy efficient modules, renewable energy usage, implementation of mitigation techniques and adaptation incorporated within a framework for investment articulates the requirement for stringent environmental standards. Subsequently, the proposed work to develop a framework for investment was taken up by the WTO Working Group on the Relationship between Trade and Investment, which noted that the framework "should reflect in a balance manner the interests of home and host countries, and take due account of the development policies and objectives of host governments as well as their right to regulate in the public interest (Doha Ministerial Agenda).

Many scholars believe that WTO could pose a problem for a global investment treaty for the simple reason that the framework could be a permanent commitment for nations, which believe that, it could infringe upon the state sovereignty, since withdrawal from the treaty would mean withdrawal from WTO itself. WTO is a rallying forum for all developing nations that cannot afford to alienate WTO, which espouses their cause at a global platform. Investors are most often private parties who might have private causes of action against the state or another private sector involved in the workings of an investment; the



WTO form of dispute settlement is bound to act as a deterrent to finalizing a global treaty. According to some, a major barrier to the establishment of a global investment treaty is that the treaty may be reduced to another law-making instrument on public international law that is binding on all members, rather than a *lex specialis*. This principle harmonizes and amalgamates special and general rules applicable to a particular subject matter and makes regulation of an issue more specific by removing redundancies.

According to author Sornarajah, multilateralism may be an impossible agenda because of “ideological rifts and clashes of interest that attend this branch of international law.” WTO may not be the answer to enforcing international environmental norms on its members, since no WTO panel has addressed the issue of conformity of a multilateral environmental trade measure with WTO rules, although WTO agreements do accommodate environmental concerns through the General Exceptions of the General Agreement on Tariffs and Trade (GATT) that have found place in a few BITs. Ultimately, it cannot be denied that environmental issues must be considered within the international investment law when investments are made and projects are commenced.

### **11. Managing a Global Repository Underglobal Administrative Law Norms**

An independent international investment treaty outside of WTO is possible using the simple maxim of “polluter pays” principle, a feature of customary international law. International investment treaties are not a homogenous group of treaties and there is no uniform terminology that runs through these agreements. With 3000 international investment agreements and almost 400 arbitrations, as per UNCTAD IIA Issues Note 1, 2011, it is impossible to analyze the impacts of these agreements on the environment of host states or understand their collective impact on the globe. The UNCTAD holds an online archive of BITs, gathered from governments throughout the world. ([http://www.unctadxi.org/templates/Startpage\\_718.aspx](http://www.unctadxi.org/templates/Startpage_718.aspx)).

There are also several licensing agreements relating to exploitation of natural resources, for example in the fishing industry, having an impact on the global ecosystems. These stand-alone agreements need to be monitored and regulated for serious violations of environmental norms including overfishing and sustainable fishing practices, and are to be treated as such within the international investment regime. But

with individual states having their own policy constraints and entering into agreements within their policy framework they remain unaccountable to the international community for playing havoc with global resources.

There is a clear need for a global institution that can regulate the environment through fundamental processes of transparency, accountability, participation and reasoning within the internal administrative decision-making processes of a nation. This is possible within the regulatory norms prescribed by Global Administrative Law (GAL). A global institution like WTO, that incorporates all the norms of GAL can be authorized to impose sanctions for lack of transparency in dealings with natural resources of their state that is likely to impact global resources and the environment, and empowered to set international standards for global environmental administration. GAL can help demand the creation of a global repository of all IIAs, investment contracts, and proprietary licensing agreements between states with regard to natural resources through incentives for adoption of GAL principles and procedures. GAL can improve global governance as it engages both domestic and international courts in reforming global regulatory governance.

According to the definition that the leading GAL Research Project of New York University School of Law has given GAL is “the body of law that comprises the structures, procedures and normative standards for regulatory decision-making including transparency, participation, and review, and the rule-governed mechanisms for implementing these standards that are applicable to formal intergovernmental regulatory bodies; to informal intergovernmental regulatory decisions of national governments, where these are part of or constrained by an international intergovernmental regime; and to hybrid public-private transnational bodies. Within this framework, the body of law that will govern the administrative action of international arrangements with competence on environmental issues defines “global environmental administrative law.” The rising body of global environmental administrative law could create a new *modus operandi* for the existing intergovernmental organizations to regulate international investments in respect of the environment.

Global administrative law may suggest the application of administrative procedures that could ensure internal and external accountability of the work of the administration and expert bodies. The emerging body of GAL could provide the framework for the

restructuring of international institutions like WTO and for the promulgation of procedural rules.

## 12. Conclusion

As is with any multilateral agreement, a global treaty on international investment is yet to fructify due to the reluctance of states to commit themselves to higher standards of treatment for foreign investments and for fear of diluting their sovereignty rights. With large volumes of investment treaties, contracts and agreements as bilateral or regional arrangements between developing states and FDI from the developed world running into billions, weaker regulatory regimes give developing nations a competitive edge over the other, a situation that requires a remedy.

A multilateral treaty can assuage fears of protectionism and commit parties to the liberalization of investment and address the needs of host state, the source state, and non-party state that seeks to impose standards of conduct on investors and hosts. One of the reasons that the negotiations failed was the need to address pre-investment and post-investment regulations within the same treaty. A post-investment regulatory treaty would have helped in circumstances where the social and environmental impact is bound to affect parties the most, especially in developing nations and economies in transition. Many argue that there is a requirement for a global treaty to delink FDI from international trade which is managed at the global level through the WTO. In another argument in favor of a global investment treaty is the complexity created by a network of 3000 BITs, each of which contains a Most Favored Nation clause guaranteeing that the best treatment offered to one country extends to all other countries leading to hike in compliance costs for both the states and investors and resulting in higher tax regimes and inflated costs for end users. With multitude of treaties dealing with international investment like the NAFTA, Energy Charter Treaty, there is bound to be confusion over treaty obligations and compliance mechanisms and in the absence of a global repository of investment agreements, it might be difficult to understand the cumulative effect of these agreements on the global commons.

A global treaty can help chalk out a monitoring and reporting mechanism that gives feedback on the environmental impact of the projects and steps taken by the parties in mitigating their effects. Whether a multilateral treaty can actually boost foreign investments is yet unclear, but it can help investors in a post-investment scenario and raise the bar on

environmental standards for the host states. The treaty can remove uncertainties created by diverse national legislations by providing necessary legal protection for foreign investors and host states. The institution that regulates international investments can assist in the implementation and enforcement of international environmental norms by imposing trade sanctions against policies of other states that could harm the environment, specially with regard to shared natural resources like rivers and airspace. Challenges faced by WTO in governing a multilateral agreement could be overcome by applying norms prescribed by Global Administrative Law (GAL), which includes transparency, participation, reason giving, review, and accountability to the WTO's administrative bodies.

The expectation for an MIA has risen with the G-20 meeting to be held at St. Petersburg Summit in September 2013. Russia and China are understandably two major foreign investors whose state-owned investments have encountered impediments. It has been suggested that MIA has to be a plurilateral agreement within the framework of the WTO and not a universal one. A newly drafted MIA should have the propensity to bring under its umbrella all the BITs and Regional Trade agreements by providing a common set of standards and obligations, including a unique dispute resolution system that meets the need of investment disputes. Many nations, unhappy with the ICSID have pulled out of the convention. With increased volume in the flows of FDI and increasing number of investment treaties have multiplied which involved almost all countries in the world.

An institution with competence on environmental issues should adopt decision-making processes and regulatory lawmaking procedures in ways similar to the so-called technical organizations. Global intergovernmental organizations with competence on specific environmental issues, such as the FAO and WHO are constituted with powers to amend technical and other regulations that become binding on their member-states without the need for ratification. International Maritime Organization demonstrated success at the mitigation of oil pollution of the seas. These procedures better serve the quick adaptation of international environmental law to new technological evolutions, and enhance the speed of response to environmental emergencies. Introduction of better technologies can hasten through the enactment of legislation promulgated by international administration and improve compliances.

Investment liberalization can be achieved within public interest objectives since states themselves are

investors and corporations incorporated in them may overlook environmental causes and the fate of its citizens to meet their own economic interests. This is very likely under volatile political conditions, where the pressure is enormous on governments to claim high economic growth. A global treaty can help control the use of investment incentives in the form of weak regulatory regimes and strengthen global governance of the environment.

## References

- [1] Asa Romson, *Environmental Policy Space and International Investment law*, 2012. Full text available online. [www.sub.su.se](http://www.sub.su.se).
- [2] Sornarajah, M. *International Law on Foreign Investment* (2<sup>nd</sup> Edition), Cambridge University Press.
- [3] OECD, 2008, *International Investment Law: Understanding Concepts and Tracking Innovations*.
- [4] *Sleeping Lions' Oxfam Discussion Paper*, May 2011.
- [5] Kathryn Gordon, and Joachim Pohl (2011), "Environmental Concerns in International Investment Agreements: a survey", OECD Working Papers on International Investment, No. 2011/1, OECD Investment Division, [www.oecd.org/daf/investment/workingpapers](http://www.oecd.org/daf/investment/workingpapers)
- [6] WF- UK Report on 'Foreign Direct Investment and the Environment: From Pollution Havens to Sustainable Development', Nick Mabey and Richard McNally, August 1999.
- [7] AlQurashiZeyad, Renegotiation of International Petroleum Agreements, *Journal of International Arbitration* 22(4): 261 – 300, 2005.
- [8] ElChiati, Protection of Investment in the Context of Petroleum Agreements, 204 *Recueil Des Cours*, 1, 99 (1987)
- [9] Gotanda, John, Renegotiation and Adaptation Clauses in Investment Contracts, *Revisited*, *Vanderbilt Journal of Transnational Law*, Vol.36:1461.
- [10] Charnovitz, Steve, "International Trade and Investment Law and Carbon Management Technologies" (2012). *GW Law Faculty Publications & Other Works*. Paper 401. [http://scholarship.law.gwu.edu/faculty\\_publications/401](http://scholarship.law.gwu.edu/faculty_publications/401)
- [11] Khan, Kabir-Ur-Rahman (1993) "Transfer of Technology, Emerging International Responsibility of Transnational Corporations: Possible Impact of the Uruguay Round at the GATT," *Third World Legal Studies: Vol. 12, Article 13*. Available at: <http://scholar.valpo.edu/twls/vol12/iss1/13>
- [12] Mann, Howard, *Reconceptualization International Investment Law: Its Role in Sustainable Development*. Based on Spoken remarks given at the 17<sup>th</sup> Annual Lewis & Clark Business Forum: Balancing Investor Protections, the Environment, and Human Rights and published in *Lewis & Clark Law Review*.
- [13] News Release by IIGCC and PRI, London/New York/Hong Kong/Sydney, November 20<sup>th</sup> 2012, "World's largest investors call for more decisive action by governments on climate change".
- [14] Avgerinopoulou, Dionysia – Theodora, "The Rise of Global Environmental Administrative Law – Improving Implementation and Compliance through the means of Global Governance.
- [15] Berger, Klaus Peter, "Renegotiation and Adaptation of International Investment Contracts: The Role of Contract Drafters and Arbitrators. *Vanderbilt Journal of Transnational Law*.
- [16] Collins, David, "A New Role For the WTO in International Investment Law: Public Interest in the Post-Neo-Liberal Period.", *Connecticut Journal of International Law*.
- [17] A. Kolo&T.Waelde, *Renegotiation and Contract Adaptation in International Investment Projects*.
- [18] Viñuales, J. E., 'The Environmental Regulation of Foreign Investment Schemes under International Law', in P.- M. Dupuy and J. E. Viñuales (eds.), *Harnessing Foreign Investment to Promote Environmental Protection: Incentives and Safeguards* (Cambridge: Cambridge University Press, forthcoming 2012), chapter 11.

## Law and Politics: Modern Aspects of Interconnection

Murman Gorgoshadze, Levan Jakeli

Batumi Shata Rustaveli State University, Georgia

Law, as the regulating instrument of the human behavior is in the complicated interrelation in other regulators of the social relationships. This difficult relation is clearly revealed in the specificity of interrelation between the law and politics. Dogmatic jurisprudence was meant under law, the concepts of the rule and law were traditionally similar and it was considered that law or same the rule was the creation of a state and ergo politics. So the understood law may be characterized as the violent instrument, which handles some standards in life based on the state coercive force.

There is an impression that the great mass of legal matter, which is expressed by obligatory norms presents the direct continuation of the state government will, that law has no own logic and it is founded only by the state will (7, p. 195-196). As the analysis show this must not be so, with the development of law it is revealed that law has its own, original thing that belongs only to law, as the unique and special event. This is also confirmed by the thing that the legal consciousness is not exhausted only by appropriate relations, its content is much broader.

In order to make the noted question clearer, it is expedient to differentiate the law and the rule. One part of the thinkers consider that the law and the rule are identical, because law exists by rule and “the rule does not have its own essence, distinguished from the law” (1, p. 148), that is why, the law does not exist without and behind the rule. The inborn rights may possibly become rule (12, p. 12). The rules are created by the state, accordingly, the rule (the same state) is the only source of the law. Accordingly, the law is spoken by the state via its rules.

Under the second point of view, it is impossible for the law to coincide the rule, because the law itself contains law, it exceeds acting legal rights and obligations, containing social-legal rights, which are not fixed in rules. By this point of view, the law, as social relations' regulator, is independent from the state, moreover, it is a system of reasoning on equity and foregoing as politics, as well as the rule and is their

basis. By this understanding the state is presented as the institution, which does not create law, but draws up, concludes it by the legislative activity from legal reality. “The law contains justice, the rule contains command” - notes Jan Boden (15, p. 168). „The rule, as the source of law, does not create but displays the law” (13, p. 26).

It is notable the fact that Federal Constitutional Court of Germany recognises such abovepositive law existence, which restricts the legislator in accepting the Constitution, by which legal force of the positive law impugnes the legal force of norms of positive law (14, p. 49).

The second point of view considers the law as the definite principles and values, as the free form of social relations, as the legal consciousness, which meaning is not defined by acting laws dependence and dependence itself foresees definite position.

Accordingly, the law cannot be unfair, and „The rule, because of influence of different social, economic, political and cultural factors as well as because of an elementary mistake, may possibly be unfair with law” (2, p. 300).

According to the above said, we should differ, the relation between the rule and politics and the law and politics.

Accordingly we should discuss double-sided relation: the first - between the rule and politics and the second one – between the law and politics.

From the beginning, the Western political science was contrary to the point of view according to which, the rule is political measure and accordingly the rule is politics. Contrary to this, the thesis on law's „political sterileness“ was arisen in the West. Obviously, such point of view is extreme, which is proved by the development of scientific thought, particularly the tendency of jurisprudence politization. For example, the German science of the state law does not reject its connection with politics, in their opinion, there is a natural connection of mutual interstipulation between the Constitution and politics (4, p. 41).

Certainly, the rule conducts political function, and there is no possibility of existence of politically absolutely neutral rule, because the rules are accepted

by one of the highest state authority legislative bodies and its acceptance-non-acceptance question has been definite politics, the rule from the other side also conducts political function, particularly:

Relations between the power and authority, which composite the content of politics, stated by the rule;

The rule regulates relations between the subjects of political system;

Political system is legally drawn up by the rule;

The state authority bodies' creation rule, structure and competence are legally drawn up by the rule;

The citizens' rights, liberties, etc are legally drawn up by the rule.

Politics will not be lead to the rule and will not be framed by it. Politics is broader than the rule. The same relation can be established between politics and rule, as between the aim and means, where the aim is politics and the rule - means.

According to specificity of the rule and politics, there is no possibility of full harmony between the rule and politics. The essence of politics does not reveal in only positive legislation. Politics has its own peculiarity of development. Particularly, there can be found formally-legal as well as actual relations in politics. Actual relations, political norms, political traditions are not foreseen by the legislator who is not obliged to foresee them, politics owns a real power, accordingly politics is a process, having its own logics of development, because of which the rule cannot frame politics in strict limits. That is why, there is the moment of the law and real political power contradiction and confluence in rule.

Accordingly, it is absolutely real, that the change of the strategy and tactic of political management to be realized independently from the rule but not from the law.

In the modern states having developed democracy strategy is formed political concept of social life transformation within the law with the further legislating basis of its realization.

More intensive is the transfer of political doctrines on rule language with the help of the law, more successful is the reform.

If we review the processes taking place in the modern democracy states, we will see the rule acquires independence with the development of the democracy process in the relations with its partner such as the state and politics and it is inclined towards the law. In such countries rule is the means of realization of justice and becomes the event conditioned by it. Compulsory force of rule is founded on the morality, the people's will, their interests in the developed democracies. Modern legal positivism does not reject the moral criteria and

assessment existence (10, p. 105). Accordingly the definer of the government behaviour or its policy is not the will of the government, nor narrow party's interests but obligation, which goes according to the "law" from life or socially and spiritually justified behavior requirement. One part of specialists, in the compulsory way, speaks about the ethic expertise of the bill in the legislation body (9, p. 90). Accordingly, we may conclude, that

- In some legal systems, especially where continental law-based approach is used, the rules play role of political statement, but details are displayed in the norms prepared and executed by administrative bodies (5, p. 42);

- The rule's obligation is to transfer politics into legal matter.

Interrelation between the law and politics is displayed in other manner. The law does not execute political function. Relation between the law, as definite principles and values and politics means the synthesis between politics and law, which should be realized in rule. He law and politics structurally differentiate from each other. Political relation is always dynamic, irrational; it tries to manage constantly changeable vital interrelations, contrary to the law which is static-rational and tries to restrict vital, dynamic forces (6. p. 103-104).

Systematization of characteristic features of the law and politics will make their marking off clearer:

- Politics cannot exist independently from the law, there is no need of especial protection for the law, as for the principles and values;

- There is a lack of systematization of political norms. Politics is more mobile than the law, and is more flexible in relation to the problem solving;

- The law is a means of compromise between interests of different social groups and individuals, politics contradicts these interests;

- Acting from the momentary interests, politics, "is the entity in the sphere of the risk, is the activity in the erratic balance of legitimacy and illegitimacy, kindness and evil" (3, p. 446). Politics may contradict the rule, but not the law, the aim of politics is usage of law, as the definite principles and values in decision making;

- It is true, political norms may impact direct social regulation and contradict and abolish the rule, but they can't abolish the law, as the principles and values, on the contrary, trying to acquire legal feature to own decisions and in such way to provide their execution. In itself political norms have no stimulating features, or if have – in the low degree (11, p. 312);

- In modern democratic countries politics may not resolve the matter without the law. Politics creates a basis for the matter resolving, the resolving of the matter is rule prerogative, which is related to the law;

- After acting in state legislative bodies, political norms become legal, as the result of which they transform from „elective condition“ into general obligation. This moment is the basis of assertion of the fact that the state authority is a source of the law and the law is political phenomenon and category;

- Legislative process is especial procedure in the state politics transforming. By this way, the state uses the law possibilities to realize its own political aims (8, p. 161);

- The law serves justice. Legislative activity should execute correlation of justice and usage in positive law or in legislation;

- When politics invades into the law, justice - essential mark of the law is changed by the usage - essential mark of politics, accordingly this correlation is reflected in the rule, because of which, the rule may be less fair and more useful;

- Politics, restricted by the law creates legal system and vice versa, by law – unlimited, ideologised politics is a basis of unfair legislation.

As we see, the law has originality in relation to politics. This phenomenon is higher than politics and authority executing its direct legal potential, its real purpose but not the authority's will.

According to all above said we may conclude, that the rule gradually finds more independence in relation to politics, more precisely – politics becomes dependent on the law and accordingly there are more justice's elements than political in the rule, which causes paradoxical situation, particularly, from one hand the rule keeps close connection with the state, and from the other hand simultaneously differentiates from politics and authority in general.

The modern aspects of the law and politics interrelation may be presented in the following way:

- In relation to politics, different from the rule, the law is characterised by the full autonomy. It is so autonomous from politics, that legal state idea is not political principle;

- In modern developed democratic countries, the rule and politics are in equal relation to the law. The law for both similarly presents assessment criterion;

- In modern developed democratic states, law's general principles present the basis of politics and legislation;

- In modern developed democratic state the main purpose of influence of the rule upon politics is

not its full legalization-formalization, but establishment of juridical requirements in political sphere.

## References

[1] Tamar Alpaidze. Introduction into jurisprudence, Tbilisi, 2009, p. 148

[2] Givi Lobzhanidze. Common theory of government and law, Tbilisi, 2010, p. 300

[3] Valerian Ramishvili, Philosophy, Tbilisi, 2009, p. 446

[4] The manner of establishment of the law, Tbilisi 2000, p. 41

[5] Seven principles of the development of legislative processes in Georgia, prepared by Mark Sigle, Tbilisi 2005, p. 42

[6] Giorgi Khubua. The theory of law, Tbilisi, 2004, p. 103-104

[7] Guram Nachkepia, Alogism in mercy (reply to professor Gamkrelidze's conclusion remarks), Tbilisi, 2001, p. 195-196

[8] AAmartia Seni, Culture and human rights // Tavisupleba, 2005, N1 (37), p. 161

[9] Rainholdtsipelius, Studies of law methods, Tbilisi, 2009, p. 90

[10] Jambul Phutkaradze, The philosophy of law, Tbilisi, 2011, p. 105

[11] С. С. Алексеев, Восхождение к праву. Поиски и решения, М., 2001, p. 312;

[12] Г.И. Иконникова, В.П. Ляшенко, Философия права, М., 2007, p. 12;

[13] А. В. Пишулин, Современный юридический позитивизм в англосаксонской правовой семье // Вестник московского университета, серия право, 2010, №4, p. 26;

[14] Ю. В. Сорокина, Введение в философию права, М., 2008, p. 49;

[15] Кудишина А. А. Политика – правовые аспекты современного гуманизма // Государство и право. №1, 2007, р. 168.



# Evaluating the Legal Concept of Reasonableness for Shareholders to Participate in Electronic Shareholders' Meeting

Nor Hayati Abdul Samat

Faculty of Law, Universiti Kebangsaan Malaysia, Malaysia  
[as.yati@uum.edu.my](mailto:as.yati@uum.edu.my)

Dr. Hasani Mohd. Ali  
Faculty of Law, Universiti Kebangsaan Malaysia, Malaysia  
[hmohdali@ukm.my](mailto:hmohdali@ukm.my)

## Abstract

*The use of technology in a shareholders' meeting is one of many ways to encourage shareholders' involvement in a company's decision-making process. However at present, there are many types of IT products available and each of them has different features. The question is whether all those products are fit to be applied in organising such a meeting? Statutory provisions of several jurisdictions including Malaysia stated that the technology to be used must allow all shareholders a 'reasonable opportunity to participate' in the meeting. This paper will analyse the phrase by re-examining the concept of reasonableness. The existing literatures on reasonableness will be explored to identify any possible implications of such phrase to the future application of technology in such meetings. In the end, this paper argues that applying technology for shareholders' meetings requires a minimum standard of judgment to ensure its fair application to parties involved.*

## 1. Introduction

The twenty first century marked the beginning of a new era that is an era of an electronic world. There is a rapid growth in the invention of technology particularly in the area of communication and information technology. The costs of technology based gadgets such as personal computers, laptops, tablets and mobile phones coupled with wireless technology such as Bluetooth are becoming more affordable made technology accessible to the public at large.<sup>72</sup> As a result, human's life is run mostly by

electronic means since most of daily transactions are done electronically. People especially youngsters are becoming less interested in sending letters or messages through an ordinary postal services. Instead, they communicate with each other through emails, SMS, tweet and through other electronic social networking.

In terms of business, most of the company's transactions nowadays are no longer need to be settled at the counter but through electronic machines and online transactions. The wave of technology in fact at present is climbing up the ladder of the company's chart of organisation and reaches the boardrooms. In line with paperless policy adopted by corporate world, all documents are no longer printed, but transmitted to the directors' Personal Digital Assistant (PDA) or their smart phones. As to shareholders' meetings, the use of technology has been identified as one of many ways to encourage shareholders' involvement in the company's decision-making process. However at present, there are many types of Information Technology (IT) products and each of them has different features. The question is whether all those products are fit to be applied in organising a general meeting i.e. an important event in a company's calendar.

Section 145A of the Malaysian Companies Act 1965 provides that the technology to be used must allow all shareholders a reasonable opportunity to participate in the meeting. Similar provisions are found in other jurisdictions. The phrase "reasonable opportunity to participate" is put in place as a condition to employ technology in organising shareholders' meetings. Since technology may be used as a support

<sup>72</sup> Warren B. Chik, 'The Lion, The Dragon and the Wardrobe Guarding the Doorway to Information and Communications Privacy on the Internet: A Comparative Case Study of Hong Kong and Singapore – Two Differing Asian Approaches' (2005) International

Journal of Law and Information Technology Vol. 14 No. 147 <<http://ijlit.oxfordjournals.org/www.ezlib.ukm.my/content/14/1/47.full.pdf+html?sid=afe78f73-790a-45d1-bc89-525132af4699>> (16 February 2012).

system in such meeting, it needs to meet the standard of “reasonableness”. What is meant by a meeting with “reasonable opportunity to participate”? According to Rossi and Curzon,<sup>73</sup> the concept of reasonableness is associated with a margin of flexibility. If it is so, does it mean that the standard of such a meeting has been reduced, as the phrase was never there in the original section 145A? As such it is the objective of this paper to identify any possible implications of the phrase to the future application of technology in the shareholders’ meetings by analysing the concept of “reasonableness”.

## 2. Methodology

This paper is an exploratory study on the legal concept incorporated in the phrase “reasonable opportunity to participate” with respect to shareholders’ meetings as a whole and in particular the application of technology in such a meeting. This is a pure legal research as the study concerns with some legal problem, issue or question<sup>74</sup> with respect to the concept of “reasonableness” as the key requirement to the application of technology in shareholders’ meetings. According to Mahdi Zahraa<sup>75</sup>, legal research is primarily concerned with an act of stating, interpreting or clarifying the existing law in a given sphere of municipality or supranational jurisdiction. For the purpose of this study, library research was conducted to collect literatures either in the form of primary or secondary data. The existing literatures on the concept of “reasonableness” collected are analysed to identify any possible definitions or trends explaining the legal effect of such concept to the future application of technology in the shareholders’ meetings.

## 3. Findings

The word “reasonable” has been used in English language as well as in law as an adjective to many things. Some writers believe that the word “reasonable” is merely rhetoric and not to elucidate anything.<sup>76</sup> Reasonable is used as a means of

disallowing the use of the word altogether and insisting that it always be replaced by a substitute.<sup>77</sup> However, an exploration into the world of reasonableness shows that the word “reasonable” serves more than a mere adjective in English language. It denotes an embodiment of good values and sometimes practical consideration in human’s conduct and action. As such, in terms of shareholders’ meeting, particularly in the electronic shareholders’ meeting, the use of a reasonable standard may afford a protection to the shareholders’ rights as the ‘owner’ of a company as well as representing the interests of the company itself.

### 3.1. Reasonable to Participate in the Meeting as a Protection of Shareholders’ Rights

“Reasonable” derives from an Old French word *raisonable* means having sound judgment, fair and sensible.<sup>78</sup> “Reasonable” may also carry the meaning of average, justifiable, logical, being practical and something that is well-thought out.<sup>79</sup> In other words, “reasonable” denotes a quality in human, things, actions, conduct or decisions with due application of good values so as to ensure fairness and justice. The legal definition of “reasonable” is in accord with its literal meaning. The Black’s Law Dictionary<sup>80</sup> defines the word as agreeable to reason,<sup>81</sup> just or proper. It may also mean ordinary or usual. Reasonableness as described by Shaw CJ is a broad general principle of justice, fairness and expedience.<sup>82</sup> It is an embodiment of fairness in the way people live and the way people conduct themselves or act. This may be the basis of Prof. Haari Chand’s argument<sup>83</sup> that reasonableness is in agreement with natural law as both belong to the same domain of rightness.

<sup>73</sup> L.S. Rossi and S.J. Curzon, An Evolving “Rule of Reason” in European Market, in Bongiovanni, G, Santor, G. and C. Valentini (eds.), *Reasonableness and Law*, Springer, New York, 2009.

<sup>74</sup> AnwarulYaqin, *Legal Research and Writing*, LexisNexis, .Petaling Jaya, 2007, p. 10.

<sup>75</sup> Mahdi Zahraa, *Research Methods. For Law Postgraduates Overseas Students*, Univision Press, Selangor, 1998.

<sup>76</sup> J.R. Lucas, ‘The Philosophy of a Reasonable Man’, (April 1963) Vol. 13 No. 51 The Philosophical Quarterly 97 <<http://www.jstor.org/>>(31 May 2012), p. 98; J.G. March, ‘Sociological Jurisprudence Revisited, a Review (more or less) of Max Gluckman’, (1956) 8 *Stanford Law Review* 489, p. 535.

<sup>77</sup> J.R. Lucas; According to the writer, although sometimes we used ‘reasonable’ to flag simple inferences which is too obvious that it need no flagging but in other time we reserve it to flag sophisticated inferences. In calling them reasonable, we mean not that they are particular instances of some standard type of inference but we believe that a reasonable man after examining those inferences will recognise its force. When challenged to say what we meant in terms other than the word ‘reasonable’, we are often at a loss what answer to return, for the word ‘reasonable’ had been chosen just because there was no other, specific term available.

<sup>78</sup> Oxford Dictionary Online <<http://oxforddictionaries.com/>> (29 August 2012).

<sup>79</sup> *Ibid.*

<sup>80</sup> Bryan A.Garner (eds.), *Black’s Law Dictionary*, 9th. Ed., West, United States of America, 2009.

<sup>81</sup> Oxford Dictionary Online ; Reason means the power of the mind to think, understand and to form judgement logically.

<sup>82</sup> As cited in Le Baron B. Colt, ‘Law and Reasonableness’, (1903) 26 *Annu. Rep. A.B.A.*341 <<http://heinonline.org/>>(3 July 2011), p. 349.

<sup>83</sup> Hari Chand, *Modern Jurisprudence*, International Law Book Services, Petaling Jaya, 2011, p. 36.

The embodiment of fairness and justice in the word reasonable may also be noticed in John Rawls's concept of "reasonable person"; an individual lives in his society. Rawls identifies reasonable persons, as those who seek 'social world in which they are free, equal and can cooperate with others on terms accepted by all'. Reasonable individuals will acknowledge that the burden of judgment applies equally to all citizens, and freely and willingly accepts the consequences of such a condition.<sup>84</sup> Reasonable person is not a cultural stereotype, but it is a personification of an idea of fair terms of interaction. Fair terms of interaction means allowing people freedom to do as they please, but also make sure that each is secure from the activities of others.<sup>85</sup> In other words, reasonable serves as the fundamental criterion for judging the acceptability and legitimacy of the public conception of justice.<sup>86</sup>

The word "reasonable" may also be linked to equality. In Rawls's own explanation, a just basic structure of society must guarantee equality of opportunity, equal liberty, and contain redistributive mechanisms to ensure that any inequalities in income and wealth are to the advantage of all in real terms.<sup>87</sup> It means that, a just society structure incorporates the idea of equality so as to ensure fair distribution of wealth among citizens.. It may prove that the idea of equality is one of the basic elements comprised in the term "justice" and for that reason, the idea of equality may be considered as an indirect value attached to the concept of reasonableness.

The incorporation of equality in the word "reasonable" is more apparent if the concept of reasonable is compared with the concept of rational. In language, both words carry the meaning that is quite identical. The first word means in accord with reason while the latter means the ability to reason. *However* in philosophy, despite the definitional similarity between the words reasonable and rational, a narrow separation exists between them. Reasonable concerns with the right and the good.<sup>88</sup> In pursuing his goal, a reasonable person takes into consideration about the other

people's interests and how his conduct or decision will affect others. In contrast, the word "rational" deals with efficiency.<sup>89</sup> In the works of John Rawls, rationality refers simply to the ability of a person to use "the powers of judgment and deliberation in seeking ends and interests peculiarly [her] own".<sup>90</sup> A rational person in making a decision or taking any action gives primary consideration to his own interests only. On the other hand, in order to be reasonable, a person's conduct must be fair-minded in reference to its effect to others. Being reasonable is to acknowledge that every members of a society has equal rights that need to be equally respected while pursuing one own interests.

These good values are important to safeguard the relationship among members of a society so as to guarantee the prosperity of the society. As such, they are to be applied as the basis of a reasonable standard especially in cases when a conduct or action of a particular party will affect another's personal rights to property such as the exercise of voting right of a shareholders in a meeting. Holding shareholders meeting is the responsibility of a company either through its directors or convene by the shareholders in a situation prescribed by the law. In choosing the appropriate type of technology to be used as a medium to assemble shareholders for such meeting, a lot of factors need to be taken into consideration by the convener of a meeting.

Fairness is definitely one of the elements that should be taken into account. Each shareholder, regardless of his size of investment in a company is assured by law to have the right to participate in a shareholders' meeting. In providing an opportunity to participate in such meeting, no shareholder should be purposely left out or else they may allege that they have been unjustly excluded in the decision-making process. In an electronic shareholders meeting, all shareholders must be able to access the technology used in holding the meeting. For instance, if a company wishes to webcast its meeting entirely online, the shareholders capability to use online delivery system is a crucial aspect need to be considered by the company.

If the proposed online meeting is carried out disregards of the facts that most shareholders are not capable of handling online system or have no access to online system, it may be considered as a deliberate exclusion for shareholders to participate and may also amount to oppression. However, if the company can prove that the shareholders have all the necessary

---

<sup>84</sup> J. Rawls, *Justice as Fairness: A Restatement*, ed. Erin Kelly, Belknap Press, Cambridge MA, (2001)p. 197.

<sup>85</sup> Arthur Ripstein, Reasonable Persons in Private Law, in G. Bongiovanni, Santor, G. and C. Valentini (eds.), *Reasonableness and Law*, Spriger, New York, 2009, p. 249.

<sup>86</sup> Shaun P. Young, 'Rawlsian Reasonableness: A Problematic Presumption?', (2006) No. 1 *Canadian Journal of Political Science* 159, p. 159.

<sup>87</sup> Arthur Ripstein, Reasonable Persons in Private Law in G. Bongiovanni, Santor, G. and C. Valentini (eds.), *Reasonableness and Law*, Spriger, New York, p. 257.

<sup>88</sup> Robert Alexy, The Reasonableness of Law, in G. Bongiovanni, Santor, G. and C. Valentini (eds.), *Reasonableness and Law*, Spriger, New York, 2009, p. 6.

---

<sup>89</sup> *Ibid.*

<sup>90</sup> J. Rawls, *Political Liberalism*, Columbia University Press, New York, (1993), p. 50.

resources or abilities to participate online, but yet they did not do so, the fact may be used as a shield against any claims by the shareholders. Thus, choosing a suitable technology in terms of shareholders meeting means choosing a technology accepted by most shareholders as it is a right thing to do.

“Reasonable opportunity to participate” may also be interpreted as an equal opportunity to participate. The underlying rule governing the relationship of a company and its shareholders is ‘equal treatment’. Opportunity to participate in a meeting should be equally available to all shareholders. As such, in cases where a significant number of shareholders have no means (resources or ability) to participate in shareholders meeting through electronic facilities, retaining a physical gathering may be the best way to conduct a meeting. The company may also hold a physical meeting together with an electronic meeting and let the shareholders decide their preferable way to get involved in the decision-making process. Using technology is an alternative and not a mandatory way to hold a meeting. The most important thing is that all shareholders are treated equally in terms of their chance to participate in the shareholders’ meeting. Whether they actually take up the opportunity given to them or not is immaterial.<sup>91</sup>

The argument that the word “reasonable” is a notation of flexibility in certain circumstances is sensible. Le Baron B. Colt<sup>92</sup> pointed out that the concept of reasonableness has been used as an indication of departure from strict rules. However it is submitted here that flexibility in this context does not mean downgrading the existing standard imposed by the law. In holding a shareholders’ meeting, it is the responsibility of the convener of the meeting to make sure that all shareholders are given the opportunity to participate. Whether it is a physical meeting or an electronic meeting, the legal requirement remains the same. The insertion of the word “reasonable” in the statutory provisions concerning the holding of such meeting should not in any way compromised with the existing requirement on opportunity of shareholders to take part in the meeting.

---

<sup>91</sup> Carol Goforth, ‘Proxy Reform as a Means of Increasing Shareholder Participation in Corporate Governance: Too Little But Not Too Late’, [1994] Vol. 43 *the American University Law Review* 379, pp. 442 – 443; according to the writer, most of shareholders initiatives are indeed enjoy little success but that will be the reason for continuous efforts to be initiated. In the writer’s own words “Without reform, shareholder proposals do not succeed; with reform, they may prevail.”

<sup>92</sup> Le Baron B. Colt, ‘Law and Reasonableness’, (1903) 26 *Annu.Rep. A.B.A.* 341 <<http://heinonline.org>(3 July 2011) p. 349.

Flexibility here means that reasonableness cannot be reduced into a definite set of rules. There is no set of exact criteria or rules that can determine what is reasonable in all circumstances. Whatever amount of opportunities needed to be reasonable, may vary from one case to another and even may vary from one person to another. No specific IT devices or system can be claimed to have met the standard of reasonable fixed by the law and fit to be used in all meetings. This applies to even the most sophisticated technology available in the present market. A meeting held in separate locations, linked by video conference may be suitable to be conducted for Company A but it may not be fit for a shareholders’ meeting in Company B. Each company has its own needs and suitability. Hence, in order to discharge the standard of reasonableness, the technology used must be able to accommodate the needs of each individual company. In case of a dispute, the question on what is reasonable or not, is for judges to decide<sup>93</sup> by weighting competing values in each case.

### 3.2. Reasonableness and Protection of the Company’s Interests

Moving away from the philosophical approach to reasonableness, the economists forwarded an alternative paradigm of reasonableness. It is based on the Hand’s formula on reasonableness. Judge Learned Hand observed that “*if the probability be called P; the injury L; and the burden B, liability depends on whether B is less than L multiplied by P; that is whether B < PL*”.<sup>94</sup> The Hand’s formula is considered as a normative definition of reasonableness.<sup>95</sup> Although this approach was developed in America, it has some presence in English academic law as well as among English judges as a perspective to be taken into account in deciding their cases.<sup>96</sup>

The economic theory to reasonableness suggests a practical consideration to decide reasonableness in

---

<sup>93</sup> Le Baron B. Colt, ‘Law and Reasonableness’, p. 349.

<sup>94</sup> *United States v Carroll Towing Co.* 159 F.2d 169, p. 173.

<sup>95</sup> Allan D. Miller and R. Perry, ‘The Reasonable Person’, (2012) Vol. 87 No. 2 *New York University Law Review* 323 <

[http://www.law.nyu.edu/ecm\\_dlv2/groups/public/@nyu\\_law\\_website\\_journals\\_law\\_review/documents/documents/ecm\\_pro\\_072577.pdf](http://www.law.nyu.edu/ecm_dlv2/groups/public/@nyu_law_website_journals_law_review/documents/documents/ecm_pro_072577.pdf) (10 December 2012); on the contrary, a positive definition of reasonableness, in the sense that it derives from reality rather than from morality. According to this test, a person’s conduct is deemed unreasonable if people actually consider it so, even if that conduct is cost-effective. It is deemed reasonable if people (or a certain portion of them) believe the conduct to be so, even if it is not cost-effective, p. 326.

<sup>96</sup> Ian Mcleod, *Legal Theory*, 4th. Ed., Palgrave Macmillan, New York, 2007, p. 173.

human's action or conduct. A person's conduct is deemed unreasonable if he or she did not take cost-effective precautions, even if no one would consider these precautions necessary under the circumstances. And the conduct is deemed reasonable if it is cost-effective, even if no one truly believes it to be reasonable. The 'cost' is that of the precautions and the 'benefit' is the reduction in risk those precautions would achieve. Although the test is often translated into monetary terms, it needs not be; costs on both sides of the 'equation' can include non-monetary factors.<sup>97</sup>

Planning a shareholders' meeting especially an electronic meeting requires a monetary consideration. Though costs incurred by shareholders to exercise their rights may be reduced, establishing proper facilities to make it work is not so cheap. In addition to physical equipment, a significant number of human resources are needed to ensure the smoothness of such a meeting. Beuthel,<sup>98</sup> in his study concluded that, in short terms, companies which choose to use online voting and meetings will face with more works and higher costs. Unless the attendees are huge in numbers, the returns will not be encouraging and it will be at the expense of the company. In the end, reasonable means the costs (monetary or non-monetary) incurred by the company, must be balanced with the "benefit" (increase in participation) gained out of the event.

As mentioned above, the choice of appropriate technology to be applied in a meeting depends so much on the company itself. Using the most expensive system may not guarantee its reasonableness if the technology is not chosen based on the nature of the company's shareholding structure. Overdoing it may lead to unnecessary expenses and it may affect the company's interests. Cost-effective use of revenue should be one of the underlying guideline in choosing the technology to be adopted. Practically, planning a shareholders' meeting is not merely about taking care the interests of shareholders but also the company. Therefore, the economic paradigm of reasonableness is a practical consideration that should not be left out in holding an electronic shareholders' meeting.

<sup>97</sup> Arthur Ripstein, *Reasonable Persons in Private Law*, p.269; according to the writer,

<sup>98</sup> Bernd Beuthel, 'Electronic Corporate Governance: Online and Virtual Shareholder Meetings and Shareholder Participation in Switzerland and Germany' Dissertation for Doctor of Business Administration, Graduate School of Business Administration, Economics, Law and Social Sciences, the University of St. Gallen Zurich (2006) <<http://www1.unisg.ch/www/edis.nsf/SysLkpByldentifier/3195/SFI/LE/dis3195.pdf>> accessed 6 February 2012; p. 60

### 3.3. The Characters of a Reasonable Meeting.

There are many types of IT products available to facilitate a meeting and each of them has features which are distinctively different. Choosing the right product may also require an understanding on the character of a meeting. A "meeting" literally means the act of coming together of a number of persons at a certain time and place, especially for discussion.<sup>99</sup> The Black's Law Dictionary<sup>100</sup> defines 'meeting' as the gathering of people to discuss or act on matters in which they have a common interest; especially the convening of deliberative assembly to transact business. The above definitions denote that "meeting" is a gathering of persons in the presence of another. Based on the fact, it may be concluded that there are five elements to constitute a meeting, namely physically presence at the same place, see and be seen, hear and be heard, identification of participants and the simultaneousness of the proceedings. Traditionally these elements are needed to form a valid meeting and as such, physical meeting was the common way to hold a meeting.

However, since the last decade of the twentieth century, the trend changed. A meeting was held in separate rooms using two-way audio visual equipment as a support system.<sup>101</sup> In 1996, the Delaware-based Corporation, Bell & Howell started to webcast its Annual General Meeting online. Facilities were provided for shareholders to follow the proceedings of the meeting. In April 2001, a Chicago-based technology consultant, Inforte Corp., which was incorporated in Delaware, held its annual meeting over the Internet. It was done with 'No Complaints' feedback.<sup>102</sup> Meetings were also held through phone conversation,<sup>103</sup> teleconference,<sup>104</sup> videoconference<sup>105</sup> or a combination of both,<sup>106</sup> traditional and modern way of meeting.

These are among instances to demonstrate that all those elements of a traditional meeting are not a mandatory requirement. The main object of holding a

<sup>99</sup> A.S. Hornby & A.P. Cowie (eds), *Oxford Advanced of Learner's Current Dictionary* (3rd. Ed.), Oxford University Press, Oxford, 1998

<sup>100</sup> B.A. Garner, et. al. (eds), *Black's Law Dictionary*. (8th. Ed.), Thomson-West, Minn, 2004

<sup>101</sup> *Byng v London Life Association Ltd.* [1990] 1 Ch 170

<sup>102</sup> J. Graham, Annual Meeting Need No Walls Can be Held via the Internet Inforte got no complaints when it had shareholders meet in virtual gathering. *Investor's Business Daily*, (November 7, 2001).

<sup>103</sup> *Wagner v International Health Promotions* (1994) 15 ACSR 419.

<sup>104</sup> *GIGA Investment Property Limited* (1995) 17 ACLR 472.

<sup>105</sup> *Bell v Burton* (1993) 12 ACSR 325.

<sup>106</sup> *In re Equiticorp International plc* (1989) 1 WLR 1010.



meeting is to transact businesses or in a company's meeting is to pass resolutions. Hence, this study found that the mode of conducting such a meeting is not an issue as long as the object of a meeting is achieved. This is supported by two opinions from the bench. Sir Nicholas Browne-Wilkinson in *Byng v London Life Association Ltd.*,<sup>107</sup> who pointed out that "Given modern technological advances, the same result can now be achieved without all the members coming face to face: without being physically in the same room they can be electronically in each other's presence so as to hear and be heard and to see and be seen." In another case, Santow J observed; "I agree that the words "meet together" connote a meeting of mind made possible by modern technology and not of bodies"<sup>108</sup>

#### 4. Conclusion

The concept of reasonableness is a familiar test, widely used in legal discourse to determine the acceptability and legitimacy of a particular conduct or action. Though there are writers who believe that reasonableness does not carry any significant meaning, an in-depth study reveals that it serves a meaningful purpose with the values embodied in the word "reasonable". Reasonable indicates fairness and justice. A reasonable conduct or action of a person is a result of proper reasoning with due consideration of what is good and right thing to do in a particular situation. Reasonableness also promotes the idea of equality. A person is being reasonable if he thinks about the effects of his conduct or action to others. However, whatever amounts to reasonable may not be determined based on a list of definite criteria. It is a question of facts that must be decided based on circumstances of each individual case.

Applying the concept of reasonableness in the electronic shareholders meeting is a reinforcement of the existing standard expected from a company in holding a shareholders' meeting. The use of technology in shareholders' meeting is introduced by the legislature in order to increase shareholders' participation in the company's decision-making. It is a discretion and the test of reasonableness is there to regulate the exercise of discretionary power so that it will not in any way compromised the minimum standard of such a meeting that is supposed to be conducted. The type of technology to be used is therefore relate to the nature and circumstance on a case to case basis. The main concerns will be that all shareholders are given a chance to take part in the

meeting even if the meeting is carried out by electronic means.

The test of reasonable serves as a protection of shareholders' rights as well as protection of the company's interests. If a company decides to hold a meeting electronically, the idea of fairness, justice and equality need to be observed. The electronic shareholders meeting should not be used for malicious intention to exclude any shareholders from participating in the meeting. The chosen technology must be within the capability of shareholders to use it. Opportunity to participate must be available to all shareholders. If a physical meeting is convenient to all shareholders, retaining it is the right way to conduct a meeting. However if the shareholders are divided, an electronic meeting may be held together with a physical meeting. Apart from that, the interests of the company should also be taken into account. In deciding which technology to be used, the costs incurred in order to employ such technology need to be considered.

In the end, choosing a suitable technology to facilitate the holding of shareholders' meeting depends on the understanding about the company itself. It is not about being trendy by using the most sophisticated IT devices or systems available. A simple tele-conference may serves the purpose well. Meeting the standard fixed by law is about accommodating the needs of each individual company. It means that the number of shareholders and the shareholders' ability to handle the technology need to be taken into consideration. Their consent to participate through electronic facilities may also be required. Apart from that, the monetary factor is also significant to be taken into consideration. A company is a profit oriented organisation and excessive or unnecessary use of revenue will be against the company's interests. Therefore, the affordability of the company to use a particular technology and the outcome expected out of it is crucial to be observed. In other words, the holding of an electronic shareholders meeting needs a proper planning and a clear understanding on the company's needs.

#### 5. References

- [1] A. D. Miller and R. Perry, 'The Reasonable Person', (2012) Vol. 87 No. 2 *New York University Law Review* 323 <  
[http://www.law.nyu.edu/ecm\\_dlv2/groups/public/@nyu\\_law\\_website\\_journals\\_law\\_review/documents/documents/ecm\\_pro\\_072577.pdf](http://www.law.nyu.edu/ecm_dlv2/groups/public/@nyu_law_website_journals_law_review/documents/documents/ecm_pro_072577.pdf) (10 December 2012).

<sup>107</sup> [1990] 1 Ch 170

<sup>108</sup> *Wagner v International Health Promotions*, pp 421 – 422.

- [2] A. Ripstein, *Reasonable Persons in Private Law*, in G. Bongiovanni, Santor, G. and C. Valentini (eds.), *Reasonableness and Law*, Spriger, New York, 2009.
- [3] A.S. Hornby & A.P. Cowie (eds), *Oxford Advanced of Learner's Current Dictionary* (3rd. Ed.), Oxford University Press, Oxford, 1998.
- [4] AnwarulYaqin, *Legal Research and Writing*, LexisNexis, .Petaling Jaya, 2007.
- [5] B.A.Garner (eds.), *Black's Law Dictionary*, 9th. Ed., West, United States of America, 2009.
- [6] B.Beuthel, 'Electronic Corporate Governance: Online and Virtual Shareholder Meetings and Shareholder Participation in Switzerland and Germany' Dissertation for Doctor of Business Administration, Graduate School of Business Administration, Economics, Law and Social Sciences, the University of St. Gallen Zurich (2006) <<http://www1.unisg.ch/www/edis.nsf/SysLkpByIdentifier/3195/SFILE/dis3195.pdf>> accessed 6 February 2012.
- [7] C.Goforth, 'Proxy Reform as a Means of Increasing Shareholder Participation in Corporate Governance: Too Little But Not Too Late', [1994] Vol. 43 *the American University Law Review* 379.
- [8] Hari Chand, *Modern Jurisprudence*, International Law Book Services, Petaling Jaya, 2011.
- [9] I.Mcleod, *Legal Theory*, 4th. Ed., Palgrave Macmillan, New York, 2007
- [10] J. Graham, Annual Meeting Need No Walls Can be Held via the Internet In forte got no complaints when it had shareholders meet in virtual gathering. *Investor's Business Daily*, (November 7, 2001).
- [10] J.G. March, 'Sociological Jurisprudence Revisited, a Review (more or less) of Max Gluckman', (1956) 8 *Stanford Law Review* 489.
- [12] J. Rawls, *Political Liberalism*, Columbia University Press, New York, (1993).
- [13] J. Rawls, *Justice as Fairness: A Restatement*, ed. Erin Kelly, Belknap Press, Cambridge MA, (2001).
- [14] J.R. Lucas, 'The Philosophy of a Reasonable Man', (April 1963) Vol. 13 No. 51 *The Philosophical Quarterly* 97 <<http://www.jstor.org/>>(31 May 2012).
- [15] Le Baron B. Colt, 'Law and Reasonableness', (1903) 26 *Annu. Rep. A.B.A.* 341 <<http://heinonline.org>>(3 July 2011).
- [16] L.S. Rossi and S.J. Curzon, An Evolving "Rule of Reason" in European Market, in Bongiovanni, G, Santor, G. and C. Valentini (eds.), *Reasonableness and Law*, Spriger, New York, 2009.
- [17] Mahdi Zahraa, *Research Methods. For Law Postgraduates Overseas Students*, Univision Press, Selangor, 1998.
- [18] R.Alexy, The Reasonableness of Law, in G. Bongiovanni, Santor, G. and C. Valentini (eds.), *Reasonableness and Law*, Spriger, New York, 2009.
- [19] S. P. Young, 'Rawlsian Reasonableness: A Problematic Presumption?', (2006) No. 1 *Canadian Journal of Political Science* 159.
- [20] W. B. Chik, 'The Lion, The Dragon and the Wardrobe Guarding the Doorway to Information and Communications Privacy on the Internet: A Comparative Case Study of Hong Kong and Singapore – Two Differing Asian Approaches'(2005) *International Journal of Law and Information Technology* Vol. 14 No. 147 <<http://ijlit.oxfordjournals.org/www.ezplib.ukm.my/content/14/1/47.full.pdf+html?sid=afe78f73-790a-45d1-bc89-525132af4699>> (16 February 2012).



# **Regulating the Conduct of Personal Representatives in Deceased's Estate Administration: Malaysian Legal Perspective**

Nor Azlina binti Mohd Noor

*Academic Staff at School of Law, College of Law, Government and International Studies,  
University Utara Malaysia / Ph.D. Candidate, International Islamic University Malaysia*  
[norazlyna@uum.edu.my](mailto:norazlyna@uum.edu.my)

Dr. Akmal Hidayah binti Halim

*Assistant Professor, International Islamic University Malaysia  
Universiti Utara Malaysia, International Islamic University Malaysia*  
[akmalh@iiu.edu.my](mailto:akmalh@iiu.edu.my)

## **Abstract**

*Personal representation in the deceased's estate administration is a very worth mentioning responsibility. It is so as one of the most common areas of conflict in the estate administration are the failure of the personal representatives who does not properly discharge their office of executorship or administratorship. The personal representatives owe duties and obligation of utmost good faith and should act with highest integrity during estate administration. This paper is based on the premise that regulating the conduct of personal representatives is highly important in order to uphold the interest of the estate beneficiaries. The duties and obligations can be used as a benchmark to reign in the swindle personal representatives by asserting on the rights of the estate beneficiaries.*

## **1. Introduction**

Administration of deceased estate in Malaysia is governed by three different backgrounds of administrative bodies. They are the Civil High Court, Small Estates Distribution Section under the Department of Director General of Lands and Mines, and Public Trust Corporation known as Amanah Raya Berhad (ARB). The values of the estate benchmarking at two million ringgit and the movability nature of the property determine the jurisdiction of the administration bodies. The Non-Small Estates which consists of property valued more than two million ringgit falls within the jurisdiction of the High Court whereas the Small Estates administration is within the jurisdiction of the Small Estates Distribution Section and Amanah Raya Berhad (ARB).

Small Estates Distribution Section governs the deceased estate consisting wholly or partly of immovable property situated in any State where the value does not exceed two million ringgit in total

value. Whereas, ARB through a special procedure known as summary administration has been vested power to administer movable property of the deceased estate in Malaysia where the total value of the not exceed six hundred thousand ringgit. The value includes any debts, but excludes the value of any property which the deceased possessed or entitled to as trustee.

However, setting aside on the existence of the difference administrative bodies, all background of jurisdiction promote for the appointment of personal representatives to manage the administration of the deceased estate.

## **2. Meaning of personal representatives**

In practice the personal representatives can be classified into two classes namely, executor and administrator. Probate and Administration Act 1959, the principal statute affecting the estate administration in Malaysia provides that 'personal representatives means the executor, original or by representation, or administrator for the time being of a deceased person, and as regards any liability for the payment of death duties includes any person who takes possession of or intermeddles with the property of a deceased person without the authority of the personal representatives or the Court'.

In other words, the difference of the two classes is based on the nature of their appointment. Executor is

normally appointed by the testator appointment as he or she is a person named in the last will of a deceased person to administer the deceased estate. It includes a person deemed to be appointed as executor in respects of settled land. Administrator on the other hand is a person appointed by the court in the event of intestacy where the deceased died without leaving any will and be granted with letters of administration. Section 33 of the Probate and Administration Act 1959 provides for the administration to be granted to one or more persons interested in residuary estate of the deceased where the deceased died wholly intestate, but the distribution of property shall be in accordance to the Section 6 Distribution Act 1958 [1]. They will also be appointed in several occasions<sup>109</sup> such as;

- a. Absence of executor; or
- b. Legal incapability of executor to act as such, or
- c. executor renounce his appointment; or
- d. the executor predeceased the testator; or
- e. all the executors die before obtaining probate or before having administered all the estate of the deceased; or
- f. the executors appointed by any will do not appear and extract probate

For the purpose of this paper, the phrase personal representatives essentially covers both executors and administrators[2]. In academic writing, executors and administrators in many occasions have been collectively described as the personal representatives of a deceased's estate (United Asian Bank Bhd v Personal representatives of Roshammah (decd) (1994) 3 MLJ 327). It is so as both parties plays the same role in the administration of the deceased estate and owed duties to the estate beneficiaries.

### 3. The needs to regulate the personal representatives

Currently, the position in Malaysia relating to the estate administration provides that there is a need to appoint personal representatives before the deceased estate can be dealt with. Once appointed, personal representatives will be vested with deceased's estate and will act as trustee to the estate beneficiaries. This is in line with section 3 of the Trustee Act 1949 which includes personal representatives in the definition of trustee under the Act.

The court in *Tay Choo Foo @ Tay Chiew Foo v. Tengku Mohd Saad @ Tengku Arifaad bin Tengku Mansur & Ors*[2009] 1 MLJ 289 held that an

<sup>109</sup> Probate and Administration Act 1959, Section 16.

administrator of the estate is a constructive trustee under the eyes of law which impliedly shows that administrator or personal representatives has trusteeship role<sup>110</sup>. However the contention is not conclusive. In the case of *Koh Siew Keng & Anor v. Koh Heng Jin*[2008] 3 CLJ 450, the Court of Appeal held that even though a person is neither a constructive trustee, nor a trustee under a resulting trust, as an executive and personal representatives of the testator's estate he fell within the broader definition of "trustee" given by the Trustee Act 1949.

Unlike the normal trustees under law of trust, personal representatives in estate administration hold both legal and equitable interest in the deceased estate. The court in *Commissioner of Stamp Duties (Queensland) v Livingston*[1965] AC 694 held that whatever property came to the executor *virtue officii*<sup>111</sup> came to him in full ownership without peculiarity between legal and equitable interests. The estate beneficiaries in reality keep neither legal nor equitable interest in but have simply a right, a chose in action to see that the estate is properly administered[3].

In Malaysia, the law in Part V of Probate and Administration Act 1959 which consists of sections 59 until 66 provide for the powers, rights, duties and obligations of personal representatives. The statutory provisions vested an enormous power upon the personal representatives to administer the deceased estate. The source of authority to legally allowed the personal representative to mingle with deceased estate can be found in grant of probate, grant of letter of administration from High Court, grant of letter of administration from Small Estate Distribution Section and Declaration and Direction order from ARB

With enormous powers and duties conferred by the laws, the personal representatives step into the shoes of the deceased and takes over the deceased's right as the owner of the property. It is obvious that whenever one person has the effective control of property but is required to act for the benefit of another, there is a possibility that they will misuse the powers that they hold [4]. For instance, personal representatives may be tempted to use the deceased estate for their own benefit rather than for the benefit of the estate beneficiaries. It is also challenging to ascertain whether the protection to beneficiaries has been truly upheld by the appointed personal representatives.

<sup>110</sup> see also *Royal Brunei Airlines Sdn Bhd v. Tan Kok Ming Philip* [1996] 2 CLJ 380; [1995] 3 MLJ 74

<sup>111</sup> Latin words literally means by virtue of their office, meaning that the executor not hold the property for their personal use but for the benefit of the beneficiaries.

Another important key point is vulnerability of estate beneficiaries in estate administration process as they actually hold the property of the estate as equitable owner and stood at the mercy of personal representatives. As fiduciary serving as executor or trustee at that particular time, the notion of the beneficiaries' vulnerability at the hands of their personal representatives cum fiduciaries is of an essence. No single definitive answer could be provided to define fiduciary. Finn [5] stated that a person will be a fiduciary in his relationship with another when and insofar as that other is entitled to expect that he will act in that other's or in their joint interest to the exclusion of his own several interests.

Beneficiaries' vulnerability curtails completely from their dependency upon their fiduciaries or utmost good faith towards the former's best interest within the confines of fiduciary relationships [6]. Vulnerability is the major focus as this doctrine is premised upon the notion that beneficiaries are generally inferior in power vis-à-vis their fiduciaries and that fiduciary law serves to dispel this disparity by imposing strict duties upon fiduciaries to act in the best interests of their beneficiaries. When fiduciaries fail to perform their duties, beneficiaries are eligible to bring claims against them for breach of duty and, where appropriate, to obtain a remedy [7].

In the case of estate administration, personal representatives are legally responsible for the estate beneficiaries' interests. The beneficiaries are powerless of assuming control over this matter as a result of their deficiency of authority pertaining to the ownership. The scenario can be nastiest if the estate beneficiaries are those who are regarded as person with legal disability which may be due to their minor age or physical or mental incapacity. Personal representatives who hold the legal and equitable interest in the deceased estate hold the higher power against the beneficiaries.

Undeniably fiduciaries possess the capacity, by virtue of their positions, to clearly or adversely affect the interests of the estate beneficiaries [8] where beneficiaries due to incapability cannot exercise complete control or ensure comprehensive monitoring [9]. Beneficiaries necessarily rely upon fiduciaries to perform their duties honourably, rendering the desired services in good faith without unnecessary exploitation. The outcome of this disparity in power relations creates the likelihood that personal representatives may abuse their fiduciary positions for personal gain or gain of third parties. In this event, personal representatives may in the course

of their action took advantage on the beneficiaries who furthermore could not legally pursue due to a lack of capacity. If the personal representatives abuse their power, fiduciary doctrine provides a mechanism for protecting the estate beneficiaries' interest [7].

Therefore there is a need to regulate the conduct of the personal representatives from being abusive and neglectful to ensure that the estate beneficiaries are protected from harm and are given their right and beneficial interest accordingly.

#### **4. Duties and Responsibilities of Personal representatives**

Generally, personal representatives' duties and estate beneficiaries' rights can be said as two sides of the same coin. Personal representatives have duties to uphold the rights and beneficial interest of beneficiaries in the deceased estate. Personal representatives are charged with gathering and taking possession and control of the assets of the estate, protecting and prudently investing those assets during administration, identifying and paying enforceable and payable debts<sup>112</sup> and obligations of the deceased person. Section 68(2) of the Probate and Administration Act 1959 provides that, '...the personal representatives shall pay all such funeral, testamentary and administration expenses, debts and other liabilities as are properly payable there out...'. In this event, with the permission from the Court, the personal representatives may be reimbursed with the reasonable testamentary and other expenses incurred by them, and also proper funeral expenses and all reasonable expenses of subsequent religious ceremonies suitable to the station in life of the deceased<sup>113</sup>.

They are also charged with determining and paying taxes related to the decedent and the estate assets, properly distributing the remaining assets of the estate to the proper heirs or beneficiaries of the decedent and lastly provide for an account to the court regarding the handling and distribution of the estate assets. It is one of the basic duties of the personal representative to render a clear and accurate account, for it is only through proper and accurate account that the beneficiaries have the means of knowing whether the deceased state is being properly administered<sup>114</sup>.

---

<sup>112</sup> Payable debts must in law be the just or lawful debts of the deceased. It was submitted thus that a statute barred debt is not provable against an estate: *Fazil Rahman & Ors v. A R S Nachiappa Chettiar* [1960] 1 LNS 26; [1963] 29 MLJ 309.

<sup>113</sup> Probate and Administration Act 1959, Section 44.

<sup>114</sup> *Damayati Kantilal Doshi & Ors v. Jigarlal Kantilal Doshi & Ors* [1995] 1 LNS 279; [1994] 4 AMR 3904, Fong

Mahinder Singh Sindhu (2005) in his book, *The Law of Wills, Probate and Administration and Succession in Malaysia and Singapore* has stated that the four main duties of personal representatives (i.e., executors and administrators) are, to collect all debts due to the estate; to pay all the debts and satisfy all the liabilities of the estate and to convert unauthorized investments into authorized ones.

In carrying out all those duties, certain powers are granted to the personal representatives. Personal representatives have wide-ranging powers. The powers may be either derived from the deceased's will or written law or from common law and equity. The powers comprise of power to sue, power to recover debts due to the deceased, power to dispose of property, power to appropriate, power to postpone distribution and power to appoint trustees to minor's property of the right of beneficiaries.

If the deceased died with a will, it is a principal duty of the executor to carry out the wishes of the testator. If there is no will, the administrator must distribute the deceased's estate in accordance with the applicable law. Although most of personal representatives' powers have been codified by written statute, their powers are not actually confined to those appearing in the statute only (Martyn & Caddick, 2008) as most rights of estate beneficiaries can be found in the principle of common law and equity.

In Malaysia, the law in Part V of Probate and Administration Act 1959 which consists of sections 59 until 66 provides the powers, rights, duties and obligations of personal representatives. The statutory provisions confer vast powers upon the personal representatives to administer the deceased estate.

Generally such law grant vast power to personal representatives to the degree that they possess the same rights and powers to sue in respect of all causes of action that survive the deceased.<sup>115</sup> They may also exercise the same powers of recovery of debts due to him at the time of his death as the deceased had when living.<sup>116</sup>

The primary power of personal representatives is to dispose of property. Section 60(3) of Probate and Administration Act 1959 states that a personal representative may charge, mortgage or otherwise dispose of all or any property vested in him as he may think proper to do so. In *Ong Thye Peng v. Loo*

*Choo Teng & Ors* [2008] 1 CLJ 121, the court remarked that this provision concerned with the manner of disposal of the property of a deceased person by his personal representatives. Furthermore in *Lau Yoke Hee & Anor v. Ting Liang Teng & Anor* [2005] 3 CLJ 770 the court held that the personal representative can dispose of property vested in him without beneficiaries consent.

The other powers and duties incorporated in the Probate and Administration Act 1959 also includes power to sell the immovable property, duty to keep an inventory of the deceased estate<sup>117</sup>, duty to pay for debts<sup>118</sup>, power to appropriate any part of the property<sup>119</sup>, power to appoint trustees of minor's estate<sup>120</sup>, and power to postpone distribution of the deceased estate before the expiration of one year from the death<sup>121</sup>. In discharging the duty, personal representatives must necessarily act with due diligence to take possession of all property of the deceased and account for any property in respect of which possession has not been made possible<sup>122</sup>. He must also assume a responsibility which he must discharge with due diligence, by making the fullest inquiries and by taking all steps that are necessary and reasonable to ascertain the total values of the deceased estate<sup>123</sup>.

## 5. Regulating the Conduct of Personal representatives

It is regularly impossible to stop those people who are dishonest from taking advantage of the opportunities for abuse that their positions bring. The critical question is generally whether sufficient remedy is available when an abuse has taken place. However Malaysian law provides some legal mechanism by which to attempt and prevent any abuses from happening and impairing the estate beneficiaries' interest to the deceased estate. It can be seen in the scope of supervision, regulation, deterrence and remedies.

---

*Ah Tai & Ors v. Fong Yoon Heng & Ors* [2004] 1 LNS 233; [2004] 7 MLJ 133

<sup>115</sup> Probate and Administration Act, 1959 (Act No.97 of 1959), section 59

<sup>116</sup> Probate and Administration Act, 1959 (Act No.97 of 1959), section 59

<sup>117</sup> Probate and Administration Act 1959, section 62. Refer also *Chung Kok Yeong v Public Prosecutor* [1941] 1 MLJ 163

<sup>118</sup> Probate and Administration Act, 1959 (Act No.97 of 1959), section 67

<sup>119</sup> Probate and Administration Act, 1959 (Act No.97 of 1959), section 74

<sup>120</sup> Probate and Administration Act, 1959 (Act No.97 of 1959), section 75

<sup>121</sup> Probate and Administration Act, 1959 (Act No.97 of 1959), section 77

<sup>122</sup> *Damayanti Kantilal Doshi v Jigarlal Kantilal Doshi* [1998] 2 MLJ 84

<sup>123</sup> *AG v Ching Kwong Yew* [1993] 2 SLR 225

## 5.1. Supervision and Regulation

The Civil High Court has inherent jurisdiction in matter relating to probate and succession in Malaysia. In practise, the court does not exercise a day to day function of supervising the activities of personal representatives and ensuring that they do not abuse their power and that they carry out their duty properly. The court actually dependent on the estate beneficiaries to bring complaints regarding the personal representatives' conduct to their attention[4].

The idea of supervision is in reality a good practice but may be due to the constraint of time and staff; the High Court could not actively play their supervisory jurisdiction. The abuse or misappropriation only happen after the personal representatives been vested with grant of probate of letters of administration as they are now are regarded as the legal owner of the deceased estate. Nevertheless, to overcome the problem, the law should introduce methods requiring the on-going supervision of personal representatives by the judiciary or by independent regulator or bodies, so that the personal representatives dealing are closely scrutinized and the potential for abuse can be greatly reduced.

The most proper solution to get the system to collaborate effectively is to get them in one particular place or one stop center. The integration of function by the administration bodies can avoid redundancy distribution application, save cost and time and will allow for an early settlement in an appropriate time and therefore remove any delay in the estate administration process. Therefore, it is time to establish a regulatory body unifying the task undertaken by current three main administrative bodies [10, 11] but maintaining the exclusive right of the Civil High Court to hear any dispute in contentious probate matter.

More effective intervention in estate administration can be achieved through greater involvement of judiciary in on-going monitoring of the personal representatives compliance with court order. The regulatory body may be given responsibility of ensuring that personal representatives do their duty properly and in accordance with the order of grant of probate or grant of letters of administration. The regulatory body can be treated as one stop centre for estate administration and can play its role in handling matters before, during and after the distribution process of deceased estate.

Generally abuse occurs because of the dishonesty of personal representatives. The choice of personal representatives is therefore of the utmost importance. Accordingly, there is no single requirement in law that

the personal representatives must be of those who at least profess some basic legal knowledge. With the exclusion of minor<sup>124</sup> and unsound mind<sup>125</sup>, anyone can be appointed as personal representatives[12]. It means that any person can be appointed as an executor by the wishes of testator in his or her will or become an administrator appointed through the administration proceedings in the event of deceased person dying intestate. The testator may thus choose whoever he likes to be the executors and he may also make provision for the substitution of someone else of his choosing if his first choice is unavailable [13].

As far as the personal representatives are concerned, the court may grant an order to the person listed under the rules of priority to apply for letter of administration under proviso section 16 of Probate and Administration Act 1959. The list starts with a universal or residuary legatee; or a personal representatives of a deceased universal or residuary legatee; or such person or persons, being beneficiaries under the will, as would have been entitled to a grant of letters of administration if the deceased had died intestate; or a legatee having a beneficial interest; and end with a creditor of the deceased<sup>126</sup>. In this event the law is silent on whether the personal representatives should possess at least a minimum standard of legal knowledge.

Obviously the greatest danger of abuses arises where the deceased estate is held and managed by a sole personal representative. Where there are multiple personal representatives, the general rule that all decision must be unanimous provides a measure of protection for the estate beneficiaries. Section 4 Probate and Administration Act 1959, allows the grant of Representation to be granted to more than four persons in regard to the same property and it may be granted to them simultaneously or at different times<sup>127</sup>.

## 5.2. Deterrence and Remedies

The law has inserted some requirement as deterrence to personal representative to ensure that they do not act in detriment of estate beneficiaries.

Firstly, appointed personal representatives have to produce security bond before been granted grant of probate or grant of letter of administration. Section 35 of Probate and Administration Act 1959 provides for a

<sup>124</sup> Probate and Administration Act, 1959 (Act No.97 of 1959), section 20

<sup>125</sup> Probate and Administration Act, 1959 (Act No.97 of 1959), section 21

<sup>126</sup> Refer the proviso of the Section 16 of Probate and administration Act 1959.

<sup>127</sup> Probate and Administration Act 1959, section 3(3)

statutory protection where there is a need for the personal representatives to provide a security by bond. Administration bond shall be in Form 162 as provided by Order 71 rule 34, Rules of Courts 2012. In this occasion, any estate administration whether with or without will annexed, the person to whom the grant is made or on whose behalf it is sealed shall give security by bond for the due administration of the estate where the gross value of the estate exceed fifty thousand ringgit.<sup>128</sup>

This requirement elucidates that the court is empowered to protect the beneficiaries from untrustworthy personal representatives through the bond security. Even though this requirement is still not sufficient as the provision had expressly excludes a trust corporation but it can be well accepted to protect the estate beneficiaries for the time being. Moreover, the protection is not absolute as the court reserves a power to ascertain the amount of sureties and also has power to dispense with securities for the due administration of an estate. The court also in special circumstances may exempt the administrators from furnishing security.<sup>129</sup>

Secondly, the High Court has imposed requirement to provide for administration oath before granting grant of probate or letter of administration. The personal representatives as fiduciary at the earliest stage will give their solemnly pledge that they will discharge their duties and function conscientiously, and in good faith and for the best interest of the estate. This is evidence by the provision inserted in Administration Oath in Form 161 in accordance with Order 71 Rules 33 Rules of Court. The form provides that the personal representative appointed by the court must make an oath that they will faithfully administer the estate of the deceased by paying his debts so far as his estate and effects according to law and they will render a just and true account of their administration when they shall thereto lawfully required. However this administration oath only applicable to Non-Small estates proceeding in High Court but no similar requirement order to personal representative in Small estates proceeding. Both Form 161 and Form 162 must be attested by a Commissioner for oaths.

Third deterrence is the law provide that every personal representative will be accounted and liable to his own conduct. Section 66 of Probate and Administration Act 1959 stated that, 'where a person as personal representative of a deceased person (including the executor in his own wrong) wastes or

converts to his own use any part of the movable or immovable property of the deceased, and dies, his personal representative shall, to the extent of the available assets of the defaulter, be liable and chargeable in respect of the waste or conversion, in the same manner as the defaulter would have been if living.'

The provision explicated that every person appointed as personal representative must ensure themselves to have a vibrant understanding of their powers and duties as they are obligated to act with the highest degree of trustworthiness and good faith in the administration of estate. It is so as any failure to appropriately discharge such duties can result in personal liability.

The estate beneficiaries who is not satisfy and unhappy by the way of personal representative administer the estate will usually seek various orders from the court to settle their problem such as monetary judgment, order to provide an account, various declaration, order to remove personal representative, order to deliver up title deeds and etc.

The estate beneficiaries also can take legal action in form of civil action such as negligence of personal representative or breach of contract or criminal action such as breach of trust or breach of administration oath. There are also several equitable remedies available to estate beneficiaries based on constructive trust, tracing or unjust enrichment.

## 6. Conclusion

The need to regulate the conduct of the personal representatives in estate administration is crucial in ensuring that the interest of the estate beneficiaries is protected against any misappropriation and abuse from them. Although there exist specific law and regulations that governed the estate administration in Malaysia, it is undeniable that the current legal framework is insufficient and there are still rooms for improvement to better regulate the personal representatives' conduct and protecting the estate beneficiaries as the vulnerable party.

## 10. References

- [1] Lexis Nexis, *Malaysian Court Practice: High Court* vol. 1. Kuala Lumpur: Lexis Nexis, 2008.
- [2] D. J. Hayton, C. C. J. Mitchell, and O. R. Marshall, *Hayton and Marshall : Commentary and Cases on the Law of Trusts and Equitable Remedies*: Sweet & Maxwell, 2005.

<sup>128</sup> Probate and Administration Act, 1959 (Act No.97 of 1959), section 35

<sup>129</sup> Re Dumseah (1890) 4 Ky 594

- [3] R. Clements and A. Abass, *Equity and Trust: Text, Cases and Materials*. Great Britain: Oxford University Press, 2009.
- [4] R. Pearce, J. Stevens, and W. Barr, *The law of trusts and equitable obligations*. New York: Oxford University Press, 2010.
- [5] P. D. Finn, "The Fiduciary Principle," in *Equity, Fiduciaries and Trusts*, ed Toronto: Carswell, 1989.
- [6] L. Rotman, "Parallel Paths: Fiduciary Doctrine and the Crown–Indigenous Relationship in Canada," ed: Toronto: University of Toronto Press, 1996.
- [7] L. I. Rotman, "The Vulnerable Position of Fiduciary Doctrine in the Supreme Court of Canada," *Man. LJ*, vol. 24, p. 60, 2012.
- [8] I. E. Davidson, "Equitable Remedy of Compensation, The," *Melb. UL Rev.*, vol. 13, p. 349, 1981.
- [9] E. J. Criddle, "Fiduciary Foundations of Administrative Law," *UCLA L. Rev.*, vol. 54, p. 117, 2006.
- [10] Akmal Hidayah Halim, *Administration of estate in Malaysia: Law and procedure*. Kuala Lumpur: Sweet & Maxwell Asia, 2012.
- [11] Abdullah Muhamad, "Ke Arah Penyelesaian Harta Pusaka Kecil Yang Lebih Bersepadu Cekap dan Cemerlang," in *Konvensyen Perwarisan Harta Islam 2007*, Kuala Lumpur, 2007.
- [12] Mahinder Singh Sindhu, *The Law of Wills Probate Administration & Succession In Malaysia and Singapore (With Cases and Commentaries)*, 2 ed. Kuala Lumpur: International Law Book Services, 2005.
- [13] C. Sawyer, *Succession, wills & probate*. Great Britain: Cavendish Publishing Limited, 1995.



**Published by IACSS 2013**

**Istanbul 2013**